

PHYSICS

COURSE - II

Electromagnetism & Thermodynamics

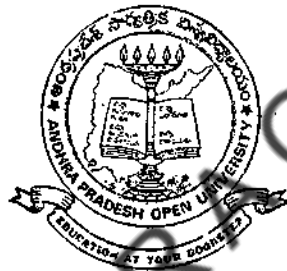

“We may forgo material benefits of civilization, but we cannot forgo our right and opportunity to reap the benefits of the highest education to the fullest extent...”

-Dr. B.R. Ambedkar

**Dr. B.R. AMBEDKAR OPEN UNIVERSITY
HYDERABAD**

2002

PREFACE

This book deals with the topics in Electromagnetism and Thermodynamics in the syllabus for the second year of the B.Sc., Course offered by Dr.B.R.Ambedkar Open University. These topics cover the core area of the subject to be studied in the second year of the three year Degree Course in Science. The syllabus is for the sake of convenience divided into Blocks, each of which comprises a number of units. Each unit generally covers a specific area of the subject. The units are prepared by specialists in accordance with a format so designed as to enable the student read and understand them without much difficulty. Each unit begins with the objectives to be achieved after going through the unit. Generally technical terms with which the student may not be familiar are given at the end of each block under the head Glossary.

Blocks 1 to 5 of the book deal with Electromagnetism. Blocks 6 deals with the branch of physics called laws of Thermodynamics. The university hopes that this course material will help the students to get acquainted with the concepts and principles of Electromagnetism and Thermodynamics.

BRAON

CONTENTS

		Page
BLOCK - 1	: VECTORS AND ELECTROSTATISTICS	
Unit - 1	: Vectors	1
Unit - 2	: Electric Fields and Gauss Theorem	27
Unit - 3	: Electric Potential	43
Unit - 4	: Capacitance	59
Unit - 5	: Parallel Plate Condenser with and without Dielectric	70
BLOCK - 2	: CURRENT DENSITY, STEADY CURRENTS AND CIRCUITS	
Unit - 6	: Electrical Conductivity	96
Unit - 7	: Kirchoff's Laws	117
Unit - 8	: Networks	132
BLOCK - 3	: MAGNETOSTATICS	
Unit - 9	: Ampere's Law	154
Unit - 10	: Biot-Savart's Law	163
Unit - 11	: Magnetic force on a circuit, Torque	177
BLOCK - 4	: ELECTROMAGNETIC INDUCTION	
Unit - 12	: Motion of charged particle	184
Unit - 13	: Determination of isotopic masses	202
Unit - 14	: Self inductance and mutual inductance	211
Unit - 15	: Faraday's Laws of Induction	218
Unit - 16	: Magnetic Energy - Maxwell's Equations	235
BLOCK-5	: VARYING CURRENTS	
Unit - 17	: LR, LC and CR circuits with A.C.	250
Unit - 18	: Transient Response	264
Unit - 19	: Series and Parallel resonance circuit	283
BLOCK-6	: LAWS OF THERMODYNAMICS	
Unit - 20	: Zeroth and First Law of Thermodynamics	296
Unit - 21	: Reversible and Irreversible Processes	305
Unit - 22	: Carnot's cycle and Carnot's Theorem	310
Unit - 23	: Second Law of Thermodynamics and Entropy	322
Unit - 24	: Thermodynamic Potentials	340
Unit - 25	: Maxwell's Thermodynamic equations and applications	346

UNIT 1: VECTORS

Contents

- 1.1 Objectives
- 1.2 Introduction
- 1.3 Basics of Vectors
 - 1.3.1 Representation of Vectors
 - 1.3.2 Different kinds of Vectors
 - 1.3.3 Some simple properties of Vectors
 - 1.3.4 (a) Scalar product of two Vectors
(b) Vector product of two Vectors
 - 1.3.5 Scalar and Vector fields
 - (a) Scalar field
 - (b) Vector field
- 1.4 Grad, del & divergence of a Vector field.
 - 1.4.1 Divergence of a Vector field.
 - 1.4.2 Derivation of the expression.
 - 1.4.2 Significance of divergence.
 - 1.4.4 Gradient of a scalar field.
 - 1.4.5 Physical Interpretation of grad.
- 1.5 Curl of a Vector field.
 - 1.5.1 Different types of vector fields.
- 1.6 Line, Surface and Volume Integrals.
 - 1.6.1 Line Integral.
 - 1.6.2 Work done by a body using the line integral.
 - 1.6.3 Surface Integral.
 - 1.6.4 Volume Integral.
- 1.7 Stoke's Theorem
 - 1.7.1 Proof of stoke's theorem
- 1.8 Gaus's Divergence theorem
 - 1.8.1 Proof of Gauss theorem
- 1.9 Summary
- 1.10 Worked out Examples
- 1.11 Sample Examination Questions

BLOCK – 1: VECTORS AND ELECTROSTATICS

BRACU

The vector sum is associative $(A+B)+C=A+(B+C)$ we draw the conclusion that the sum of Vectors A, B, C is independent of the order in which they are added.

(b) **Subtraction of Vectors:** Here we shall subtract one vector from the other i.e., 'B' from vector 'A'. The subtraction of the vector 'B' from 'A' is equivalent to the addition of (-B) with 'A' i.e. $A-B=A+(-B)$. The negative sign means a vector of equal magnitude but opposite direction. This procedure is illustrated in Fig 1.4 below:

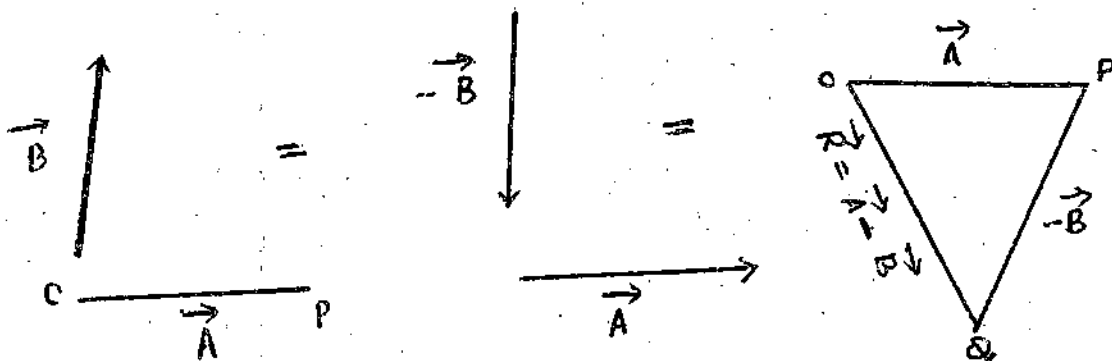

Fig 1.4

Here we draw a line 'OP' to represent the vector 'A' and then from the head 'A' another line 'PQ' is drawn to represent vector (B). Further the tail of 'A' is joined to head of (-B). Now the line 'PQ' represents a vector 'R' which is difference of two vectors A & B.

When A & B are in the same direction, $(A-B)$ is a vector whose length is $(A-B)$ and the direction is along the longer vector. If the two vectors A & B have the same length and direction then their difference is a null vector. Further

$$(A - B) = - (B - A) \quad \dots(1.2)$$

(c) **Multiplication of a vector by a scalar:** When a vector 'A' is multiplied by a scalar or a pure number 'n' then the resultant vector may be written as

$$R = nA \quad \dots(1.2(a))$$

The magnitude of vector 'R' being 'n' times of vector 'A' and the direction is the same as that of 'A' when 'n' is positive but opposite when 'n' is negative.

When the scalar 'n' is a physical quantity with a unit, then the unit R will be different from 'A'

Example: 1) when mass (scalar) is multiplied by velocity (vector) then the product (mv) represents the momentum, which is a different quantity i.e. is a (vector)

2) Similarly when 'mass' multiplied by acceleration which are scalar and vector quantities respectively results in 'Force' which is a vector quantity ($F=ma$)

Thus, we draw conclusion that when a vector is multiplied by a scalar quantity it gives result to a vector quantity, but this is not always true.

1.3. BASICS OF VECTORS

In the past, Astrologers in order to establish the place of planet from other planet, it seems they have for the first time introduced vectors. They have established the fact that any line joining two planets is a vector. That is why a scalar has no direction but only magnitude such as density, volume, length etc, whereas a vector has got both magnitude and direction such as force velocity, acceleration etc.

1.3.1 Representation of a vector:

Let 'O' be an arbitrary fixed point in space and 'P' be any other point in it. Then the straight line 'OP' has magnitude as well as direction. Therefore the directed line segment 'OP' is capable of representing a vector quantity. We denote the vector as \vec{OP} or simply by \vec{OP} and read it as 'OP' \rightarrow p.

Example: A body has a magnitude of 20 mts/sec and traveling with a velocity as that from east to west then the direction is as indicated in the arrow. Whereas speed if we take it, is having only magnitude but no direction. Thus we say speed is a scalar quantity, whereas velocity is a vector quantity. In general terminology we on so many occasions velocity and speed are being mixed up but it is not one and the same. Direction must be specified in order to define a vector.

Different kinds of vectors: (Concept & Details)

(a) Zero or Null vector: The zero or null vector is a vector whose modulus is zero and whose direction is indeterminate. The null vector is represented by the symbol, $\vec{0}$. In case of a null vector the initial and terminal points coincide. Thus AA, OO are null vectors.

(b) UNIT VECTOR: A vector whose modulus or magnitude is unity is called a unit vector.

LIKE & UNLIKE VECTORS: Two vectors having the same directions are called like vectors and those having opposite directions are called unlike vectors. If \vec{a} is a vector having magnitude $|\vec{a}|$ as a result the Unit vector \hat{a} has same direction $\hat{a} \Rightarrow \vec{a} = |\vec{a}| \hat{a}$ $\therefore \vec{a} = |\vec{a}| \hat{a}$

(c) Collinear or Parallel Vectors: Vectors having the same line of action or having the lines of action parallel to one another are called collinear parallel vectors.



Fig. 1.1

(D) Equal Vectors: The vectors are said to be equal if and only if they are parallel and have the same sense of direction and the same magnitude.

The starting point of the Vectors are immaterial. It is the direction and magnitude which is of importance. To denote equal vectors, the sign ($=$) is used, Thus if \vec{a} & \vec{b} are equal vectors,

$$A \times B = A \sin \theta n = AB \sin \theta n = 0 \quad \dots(1.6 (b))$$

(iii) The vector of unit orthogonal vectors i, j & k have the following relations.

$$\begin{aligned} i \times i &= j \times j = k \times k = 0 \\ i \times j &= -j \times i = k \\ k \times i &= -k \times j = i \\ k \times i &= -i \times k = j \end{aligned} \quad \dots(1.7)$$

(iv) The vector product of 2 vectors in terms of their x, y & z components can be expressed in the form of determinant

$$\text{If } A = i A_x + j A_y + k A_z$$

$$B = i B_x + j B_y + k B_z$$

$$\text{Then } A \times B = \begin{vmatrix} i & j & k \\ A_x & A_y & A_z \\ B_x & B_y & B_z \end{vmatrix} \quad \dots(1.8)$$

1.3.5. Scalar and vector fields

It is a known fact that a physical Quantity can be expressed as a continuous function of position of a point in the region of space.

For example, when a rod is heated at one end, there is a variation of temperature along the length of the rod. The physical quantity temperature at any point (x, y, z) can be expressed by a continuous functions $T(x, y, z)$. Such a function is termed as a joint function or function of position. The region specifying the physical quantity the field may be a scalar or vector. About these two quantities it is explained in the following articles.

1.3.5 (a) Scalar field: The scalar field in three dimensions can be represented by a scalar point function $\phi(x, y, z)$. For example the electric potential due to a single +ve charge 'q' coulombs depends upon the position of the point from the charge. Then $V_0(x_0, y_0, z_0)$ and $V_1(x_1, y_1, z_1)$ are the scalar point functions at (x_0, y_0, z_0) & (x_1, y_1, z_1) . Now the region will be a scalar field.

The concept of a scalar field can easily be understood with the help of the following example.

(i) Consider a block of material whose faces are maintained at different temperatures. Now the temperature of the body will vary from point to point i.e. temperature will be a function of position co-ordinates (x, y, z) in a rectangular co-ordinate system. Hence the conclusion is drawn that temperature is a scalar field.

(ii) The density at any point inside a body occupying given region is a scalar field.

(iii) $\phi = 2xyz \neq x^2y$ defines a scalar field.

of charge of A_x along the axis. Similarly dA_y/dy & dA_z/dz will be the rates of charge of A_y and A_z along the y & z axes respectively.

The volume of A_x at the center M of face $PQRS$

- = Volume of A_x at center C + increase in magnitude from C to M
- = Volume of A_x of centre + rate of change X distance

$$= A_x + \frac{dA_x}{dx} \times \frac{Ax}{2} = A_x + \frac{1}{2} \frac{dA_x}{dx} dx \quad \dots(1.10)$$

Similarly the magnitude at the centre N of face

$$EFGH = A_x - \frac{1}{2} \frac{dA_x}{dx} dx \quad \dots(1.11)$$

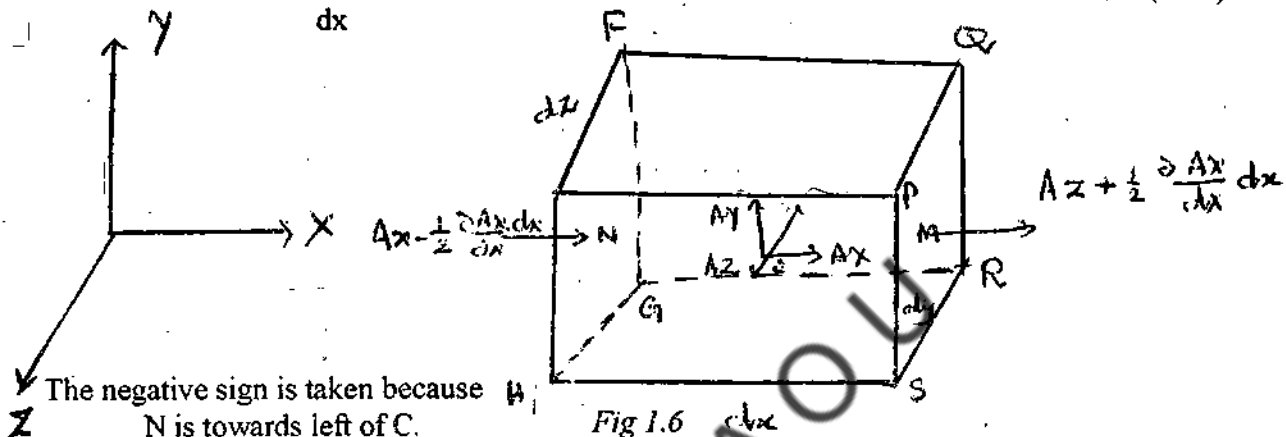

The negative sign is taken because N is towards left of C .

We know that the volume of fluid flowing per unit time through a faces equal to the product of the area of face and normal component of vector upon it. This is known as flux through the face. Hence flux entering the face.

$$EFGH = \left(A_x - \frac{1}{2} \frac{dA_x}{dx} \right) dy dz$$

Where $dy dz$ is the area of face $EFGH$ and flux leaving the parallelepiped over that entering in X -direction is given by

$$\begin{aligned} & \left[A_x - \frac{1}{2} \frac{dA_x}{dx} dx \right] dy dz - \left[A_x + \frac{1}{2} \frac{dA_x}{dx} dx \right] dy dz \\ &= \frac{dA_x}{dx} dx dy dz \end{aligned}$$

Similarly the net flux leaving the parallelepiped in Y and Z direction are

$$\frac{dA_y}{dx} dx dy dz + \frac{dA_y}{dz} dx dy dz$$

Total flux leaving or diverging from parallelepiped

$$\begin{aligned} &= \frac{dA_x}{dx} dx dy dz + \frac{dA_y}{dy} dx dy dz + \frac{dA_z}{dz} dx dy dz \\ &= \left(\frac{dA_x}{dx} + \frac{dA_y}{dy} + \frac{dA_z}{dz} \right) dx dy dz \end{aligned}$$

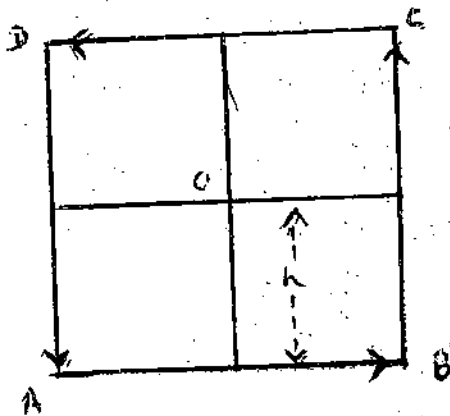

Fig 1.8

In order to deduce the expression for the curl we shall follow the figure as shown in fig 1.8

In order to find the component of Curl, in figure xy, yz, zx planes to be considered as closed circuits. ABCD is a circuit having side $2h$ components of V are V_x, V_y, V_z . Along ABCD, $\oint U \cdot ds$ is time integral. In this $ds \rightarrow AB, CD$ along y -axis like wise BC, DA along Z -axis.

Therefore along AB, CD we consider U_y , along BC, DA we consider U_x that is enough U_x, U_y, U_z are the co-ordinates of 'O' & the co-ordinates of U.

Along AB, U_y value:

$$U_y - \left(\frac{dU_y}{dz}\right)x - \left(\frac{dU_y}{dy}\right)y$$

$$\text{Along CD, } U_y + \left(\frac{dU_y}{dz}\right)x + \left(\frac{dU_y}{dy}\right)y$$

Along AB the value of line integral value

$$\int_A^B U \cdot ds = \int_{-h}^h \left[U_y - \left(\frac{dU_y}{dz}\right)h + \left(\frac{dU_y}{dy}\right)y \right] dy$$

$$2h(U_y) - 2h^2 \left(\frac{dU_y}{dz}\right) \dots \dots \dots (1.26)$$

Similarly for side CD,

$$\int_C^D U \cdot ds = \int_{-h}^h \left[U_y + \left(\frac{dU_y}{dz}\right)h + \left(\frac{dU_y}{dy}\right)y \right] dy \dots (1.27)$$

$$2h(U_y) - 2h^2 \left(\frac{dU_y}{dz}\right)$$

Let $S(x, y, z)$ be any continuously differentiable scalar function depending on the three Cartesian co-ordinates in space. Suppose ds/dx , ds/dy , ds/dz be the partial derivatives along the three perpendicular axes respectively. Now the gradient of the scalar function S can be defined as

$$\text{Grad } S = i \frac{ds}{dx} + j \frac{ds}{dy} + k \frac{ds}{dz} \quad \dots(1.14)$$

or $\text{grad } S = \nabla S$ where $\nabla = i \frac{d}{dx} + j \frac{d}{dy} + k \frac{d}{dz}$ generally called del or del operator.

1.4.5. Physical Interpretation of grad S

The scalar field can be mapped out by a series of level surfaces. Consider two such surfaces, very close to each other all shown in figure 1.7

These surfaces are specified by constant scalar functions S and $S + ds$ respectively. Consider the two points P & R on the level surfaces S_1 and S_2 respectively.

Let ' r ' and $(r + dr)$ be the position co-ordinates of P & R respectively with respect at any arbitrary origin: then

$$PR = dr$$

If co-ordinates of P are (x, y, z) and of R are $(x + dx), (y + dy), (z + dz)$ then

$$dr = idx + jdy + kdz \quad \dots(1.15)$$

As the continuous scalar function at $P(x, y, z)$ has the value S and at $R(x + dx, y + dy, z + dz)$ has the value $S + ds$; we have

$$ds = \frac{ds}{dx} \cdot dx + \frac{ds}{dy} \cdot dy + \frac{ds}{dz} \cdot dz \quad \dots(1.16)$$

This equation may also be written as

$$ds = i \left(\frac{ds}{dx} + j \frac{ds}{dy} + k \frac{ds}{dz} \right) (idx + jdy + kdz) \quad \dots(1.17)$$

$$= (\nabla S) \cdot dr$$

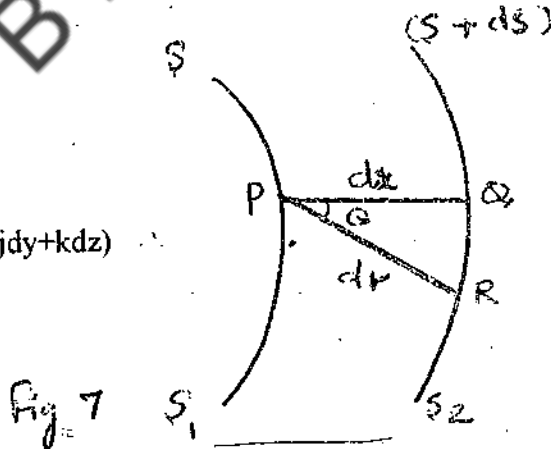

In particular if we consider that dr (i.e. point R) lies in the level surface S_1 , then

$$ds = 0, \text{ i.e., } (\nabla S) \cdot dr = 0 \quad \dots(1.18)$$

Showing here that the vector ∇S is normal to the surface S_1 (i.e. the surface $S = \text{constant}$). If dx denotes the divergence along the normal from point ' P ' to the surface S_2 , we may write

$$dx = PQ = ds \cos \theta = \hat{n} \cdot dr \quad \dots(1.19)$$

Example (1): Consider the velocity field of water flowing in a river, if there is a deep pot in the bed of river, then the velocity of water flowing has rotational component around that point. Consequently the water whirls rapidly if a swimmer gets into this region, he starts rotating rapidly and it becomes very difficult for him to get out of the region.

Example (2): When a rigid body is in motion, then the curl of its linear velocity at any point gives twice its angular velocity in magnitude and direction.

$$\text{Curl } \mathbf{U} = 2\vec{\omega} \quad \dots (1.34)$$

Example (3): When a current is passed through a conductor, then magnetic field is developed around it. At any nearby point the curl of the magnetic field represents the current per unit area passing through that point. So curl \mathbf{B} is also known as magneto motive force.

1.5.1. Different types of vector fields

1) Field where, having no divergence and no curl

In this case $\nabla \cdot \mathbf{A} = 0$ & $\nabla \times \mathbf{A} = 0$

The examples of such fields are: steady state flow, electrostatic field, gravitational field, irrotational motion of incompressible ideal fluid etc.

2) Where in field having divergence and not curl

In this case, $\nabla \cdot \mathbf{A} \neq 0$ but $\nabla \times \mathbf{A} = 0$

The examples of such field are: gravitational field inside a mass, electric field with in a volume distribution of charge, time independent schrodinger's equation etc.

3). In a field having curl and no divergence.

In this case, $\nabla \times \mathbf{A} \neq 0$ but $\nabla \cdot \mathbf{A} = 0$

Examples of such fields are: Magnetic field due to steady current, incompressible fluid with velocity etc.

4) Field having curl and divergence:

In this case, $\nabla \times \mathbf{A} \neq 0$ & $\nabla \cdot \mathbf{A} \neq 0$

The Maxwell's equations within matter are examples of such field.

1.6 LINE, SURFACE & VOLUME INTEGRALS (INTEGRATION OF VECTORS)

1.6.1 . Line Integral

The integration of a vector along a curve is called its line integral.

As shown in figure 1.9 let 'AB' be curve drawn between two points A & B in a vector field. Let 'dl' be an element of length along the curve 'AB' at R.

In general, the forces F acting on the object varies from point to point. For example, the force on a charged particle in an electric field would be function of x, y, z . However, along a curve, x, y, z are related by the equation of the curve. Since along a curve there is only one independent variable we can write $F \cdot dr = i dx + j dy + k dz$ as functions of a single variable. The integral of $dw = F \cdot dr$ along the given curve is then reduced to one ordinary integral of a function of one variable and the total work done by F in moving an object say from A to B , can be determined as shown in fig 1.10. This integral is also used in conservative field:

Another good example would be if ' r ' represents the electric field intensity at any point, then the integral represents the potential difference between A & B .

1.6.3. Surface Integral

If in a surface area of ' S ' an infinitesimal area ' ds ' is considered and if A is a vector at the middle of the element ' ds ' in a direction making an angle θ with the unit positive (outward drawn) normal to ds fig (1.11)

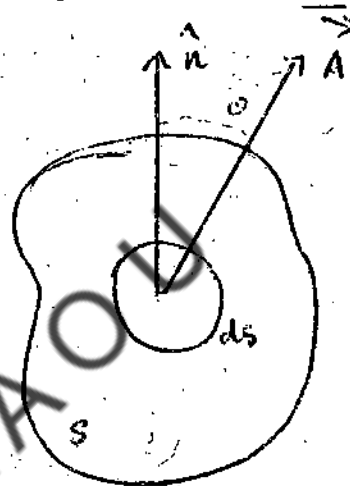

Fig 1.11

Then the integral over the surface

$$\iint A \cdot ds \Rightarrow \iint A \cdot \hat{n} \cdot ds \Rightarrow \iint A \cos \theta \, ds \quad \dots(1.37)$$

is defined as the surface integral or total flux of ' A ' through the whole surface S .

As an example if A represents the velocity of a moving fluid in which a fixed surface ' S ' is drawn then $\iint_S A \cdot ds$ represents the rate of flow of fluid through the surface S .

1.6.4. Volume Integral

Let us consider a closed surface in space enclosing a volume V . If A is vector function inside it and dv is a small element of volume then.

$$\iiint A \cdot dv \Rightarrow \iiint (\hat{i} A_x + \hat{j} A_y + \hat{k} A_z) \, dx \, dy \, dz$$

is called the volume integral of ' A ' over the volume V . ($dv = dx \, dy \, dz$).

1.7.1 Proof stoke's theorem

Let us consider a surface 'S' with C as its bounding & is enclosed in a vector field A.

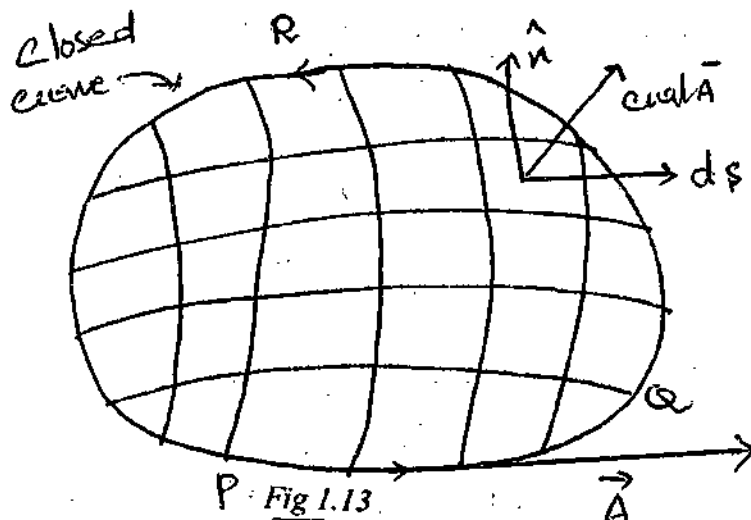

Fig 1.13

As shown in figure the bounding of the surface S is a closed curve 'PQR'. The line integral A around the curve. PQR traced counter clockwise is

$$\oint \vec{A} \cdot d\vec{r} \quad \dots(1.40)$$

Let the entire surface be divided into a large number of square loops. Let the area enclosed

by each infinite small loop be ds . Suppose \hat{n} be a unit positive outward normal to ds . The vector area of the element is

$$\hat{n} \cdot ds = ds \quad \dots(1.41)$$

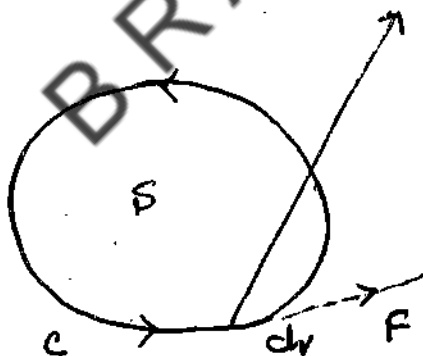

Fig 1.14

We know that curl of a vector field at any point is the maximum line integral of the vector computed per unit area along the boundary of an infinitesimal area at that point. So the lineintegral of A around the boundary of the area ds is

$$\iint_S \text{Curl } \vec{A} \cdot d\vec{s} \quad \dots(1.41)$$

This is the surface integral of A. from the fig 1.14 it is clear that the line integral along the common sides of the continuous element, mutually cancel because they traverse in opposite directions. Now the sides of the elements which lie on the periphery of the surface (i.e. in the

component of A along n is.

$$A \cos \theta \Rightarrow A \cdot n \quad \dots(1.46)$$

The flux of A through the surface element ds is given by $(A \cdot n) ds \Rightarrow A \cdot ds \quad \dots(1.17)$

(∴ Flux is defined, as the product of normal component of vector is surface area)

So the total flux through the entire surface S is given by $\iint_S A \cdot ds \quad \dots(1.48)$

This must be equal to the total flux diverging from the whole volume V enclosed by the surface S.

Hence from equation 1.45 & 1.48 we get

$$\iint_S A \cdot ds \Rightarrow \iiint_V \text{div } A \cdot dv \quad \dots(1.49)$$

This is Gauss theorem of divergence. Gauss theorem may also be written as

$$\iint_S (A \cdot n) ds \Rightarrow \iiint_V (\nabla \cdot A) dv \quad \dots(1.50)$$

1.9. SUMMARY

In fields especially in general, physical quantities have different values at different points in space. Thus for example, the temperature in a room varies from place to another, place, being higher near a fire place and lower near an open window. Similarly the electric field near a point charge is larger that at points farther from it. Similarly the magnetic field or intensity near a current carrying conductor is more at nearer to conductor and less away from it. The expression field is used to imply both the region and the value of the physical quantity in the region (electric field, gravitational field or magnetic field etc.)

If the physical quantity is of the scalar category (for ex temperature) then we are only concerned with scalar field. However if the quantity is that of vector type (for ex electric field, magnetic field due to a steady current, incompressible fluid with velocity etc.

The general meaning of curl is rotation when curl A is zero, it means that no rotation is attached with vector A where as curl A is non zero, it means that rotation is attached with vector A.

To make it clearer, consider the flow of a liquid. Let a friction less paddle is placed in the path of the liquid flow. In a hypothetical case, if we assume that all the liquid layers are moving with the same velocity which in the present context paddle will not rotate. This shows that the curl of velocity vector is zero. If we consider that the different layers are moving with different velocities (as in the actual case), then the paddle will rotate. The rotation is due to non zero value of curl of velocity vector. Like the one above many such similar problems can be dealt with the aid of vectors and vector theorems and rules.

Check your progress: Answers.

1. Divergence is a Scalar quantity, because it represents simply the amount of flux.
2. The divergence of a vector field at any point is defined as the amount of flux/unit volume diverging from that point.

(8) Using stokes theorem, prove that

$$\oint_C \mathbf{r} \cdot d\mathbf{l} = 0, \text{ where } \mathbf{r} \text{ is position vector.}$$

Solution: By stokes theorem we know

$$\oint_C \mathbf{A} \cdot d\mathbf{l} = \iint_S \text{curl } \mathbf{r} \cdot d\mathbf{s}$$

Replacing the vector A by the position vector r, we get

$$\oint_C \mathbf{r} \cdot d\mathbf{l} \Rightarrow \iint_S \text{curl } \mathbf{r} \cdot d\mathbf{s} \Rightarrow \iint_S \mathbf{0} \cdot d\mathbf{s} \text{ (curl } \mathbf{r} = \mathbf{0})$$

$$\text{Hence } \oint_C \mathbf{r} \cdot d\mathbf{l} \Rightarrow 0$$

(a) Using stokes theorem, prove that $\text{curl grad } \phi = 0$

Solution: According to stoke's theorem

$$\text{We know } \oint_C \mathbf{A} \cdot d\mathbf{l} = \iint_S \text{Curl } \mathbf{A} \cdot d\mathbf{s}$$

Let $\mathbf{A} = \text{grad } \phi$, then

$$\oint_C \text{Grad } \phi \cdot d\mathbf{l} = \iint_S \text{curl grad } \phi \cdot \hat{n} \cdot d\mathbf{s}$$

$$\text{But grad } \phi \cdot d\mathbf{l} \Rightarrow \left(i \frac{d}{dx} + j \frac{d}{dy} + k \frac{d}{dz} \right) (i dx + j dy + k dz)$$

$$\Rightarrow \frac{d\phi}{dx} + \frac{d\phi}{dy} + \frac{d\phi}{dz} = d\phi$$

$$\oint_C d\phi \Rightarrow [\phi]_A \text{ where 'A' is any point on C} \Rightarrow 0$$

$$\text{Hence } \iint_S \text{curl grad } \phi \cdot \hat{n} \cdot d\mathbf{s} = 0$$

This is true for all surface elements 'S' i.e. $\text{curl grad } \phi = 0$

1.11. SAMPLE EXAMINATION QUESTIONS

1. a) What do you understand by the gradient of a scalar field? Explain the physical significance.
b). Obtain an expression for the gradient of scalar function in rectangular Co-ordinates.
2. a). Explain the physical significance of divergence of a vector field.
b). Derive an expression for $\text{div } \mathbf{A}$ in terms of Cartesian Components.
3. a). Explain Curl of a vector field. Give its physical significance also meaning of curl.
b). Derive an expression for curl of a vector field show that $\text{Curl } \mathbf{A} = \nabla \times \mathbf{A}$

b) $r \cdot A \Rightarrow (ix + jy + kz) \cdot (iAx + jAy + kAz)$

$\Rightarrow xAx + yAy + zAz$

$\therefore \Delta(r \cdot A) = \left(i \frac{d}{dx} + j \frac{d}{dy} + k \frac{d}{dz} \right) (XAx + YAy + ZAz)$

$= iAx + jAy + kAz = A$

(3) If the gravitational potential at any point is $(-GM/r)$, where 'r' is the position vector of the point, find the intensity of gravitational field at the point

Solution: Here $V = ix + jy + kz$

Also $r = (x^2 + y^2 + z^2)^{1/2}$

Intensity $= \nabla(-GM/r) = -GM \nabla(1/r) = -GM \nabla(x^2 + y^2 + z^2)^{-1/2}$

$\Rightarrow -GM \left\{ i \frac{d}{dx}(x^2 + y^2 + z^2)^{-1/2} + j \frac{d}{dy}(x^2 + y^2 + z^2)^{-1/2} + k \frac{d}{dz}(x^2 + y^2 + z^2)^{-1/2} \right\}$

$\Rightarrow -GM \left\{ i (-1/2)(x^2 + y^2 + z^2)^{-3/2} \cdot 2x + j (-1/2)(x^2 + y^2 + z^2)^{-3/2} \cdot 2y + k (-1/2)(x^2 + y^2 + z^2)^{-3/2} \cdot 2z \right\}$

$\Rightarrow -GM \frac{ix + jy + kz}{(x^2 + y^2 + z^2)^{3/2}} = GM \frac{r}{r^3} = \frac{GM}{r^2}$

(4) If $A = iy + j(x^2 + y^2) + k(yz + zx)$, then find curl A at point $(2, 2, -2)$

Solution: We know that $\text{curl } A = \nabla \cdot A$

$\therefore \text{Curl } A = \begin{vmatrix} i & j & k \\ d/dx & d/dy & d/dz \\ Ax & Ay & Az \end{vmatrix} = \begin{vmatrix} i & j & k \\ d/dx & d/dy & d/dz \\ y & x^2 + y^2 & yz + zx \end{vmatrix}$

$\Rightarrow i \left\{ \frac{d}{dy}(yz + zx) - \frac{d}{dz}(x^2 + y^2) \right\} + j \left\{ \frac{d}{dz}y - \frac{d}{dx}(yz + zx) \right\} + k \left[\frac{d}{dx}(x^2 + y^2) - \frac{d}{dy}y \right]$

$\text{Curl } A = i(z - 0) + j(0 - z) + k(2x - 1)$

$\Rightarrow iz - jz + k(2x - 1)$

Substituting the values we get

$\text{Curl } A = -2i + 2j + 3k$

(5) Find the constants a, b, c so that

Vector $A = i(x + 2y + az) + j(bx - zy - z) + (4x + cy + 2z)$ is irrotational.

Solution: The vector is irrotational when $\text{curl } A = 0$

UNIT -2: ELECTRIC FIELDS AND GAUSS THEOREM

Contents

2.1 Objectives

2.2 Introduction

2.3 Intensity of electric Field

2.4 Intensity of Field on the surface of a charged conductor-Coulomb's Theorem.

2.5 Lines of Force

2.6 Electric Induction

2.7 Electric Displacement

2.8 Gauss theorem

2.9 Application of Gauss Law to the field

2.9.1 Application of Gauss Law

Intensity of Field of uniformly charged sphere

2.9.2 When the point P lies inside the sphere

2.10 Summary

2.11 Model answers

2.12 Sample examination questions

2.1 OBJECTIVES

This unit introduces you to the concept of electric field and its intensity. To help you understand the concepts the unit explains

1. The electric field and electric field intensity
2. Lines of forces
3. Gauss Theorem

By going through this unit you will understand what is an electric field and lines of forces and what Gauss theorem means. You will also understand how the lines of forces are used in explaining the electrical induction and how Gauss theorem is used for various electrical problems.

$$F = \frac{q_1 q_2}{K r^2} \quad \dots(2.1)$$

K is the dielectric constant of the medium where in both q_1 and q_2 are situated. But the force, acting on unit charge (i.e. $q_2=1$) placed at a distance r from q_1 is by definition, so the electric field intensity

$$E = q_1 / K r^2,$$

$$\text{Hence } F = q_2 E$$

$$\vec{E} = \frac{q_1 \hat{r}}{4\pi \epsilon_0 K r^2} \text{ N/Coulomb}$$

Above eqn. gives us a new definition of electric field intensity \vec{E} . We can define \vec{E} as,

$$= \frac{q_1 \hat{r}}{4\pi \epsilon_0 r^2} \quad ; \text{ if } K = 1$$

$$= 9 \times 10^9 \frac{(q_1)}{r^2} \text{ N/Coulomb}$$

In CGS units $E = q/Kr^2$ dynes/esu or esu/cm

2.4 INTENSITY OF FIELD ON THE SURFACE OF A CHARGED CONDUCTOR COULOMB'S THEOREM

Consider a tube of force originating from small area ds on the surface of a charged conductor. This has a surface density σ and is placed in a medium of dielectric constant k

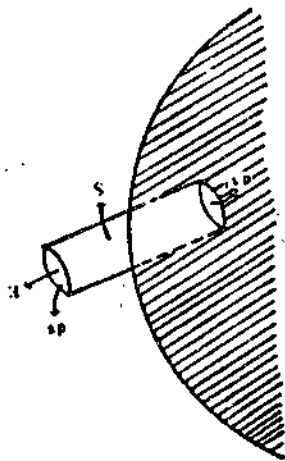

Fig 2.1 Coulomb's theorem

Solution : The charge on an elemental area at R is ds , and if r is its distance from A, the electric intensity it produces at A is $\frac{\sigma ds}{4\pi\epsilon_0 r^2}$ along RA, its component along the normal AN is $\frac{\sigma ds \cos\theta}{4\pi\epsilon_0 r^2}$

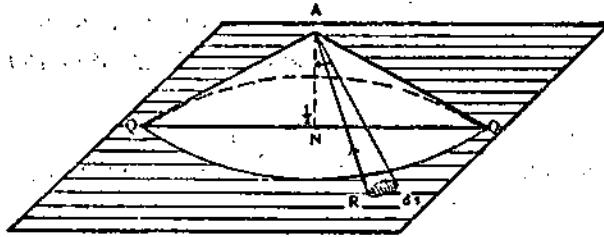

Fig 2.2. Electric field intensity of a right circular cone

Or $\frac{d\omega}{4\pi\epsilon_0}$ where $d\omega$ is the solid angle subtended at A by ds .

The points of the plane which lie within an inch of A, lie within a circle of center N and radius NQ, where $AQ=1$. The charge on this circular area, thus contributes to the total intensity at A an amount:

$$\frac{d\omega}{4\pi\epsilon_0} = \frac{\sigma 2\pi (1 - \cos 60^\circ)}{4\pi\epsilon_0} = \frac{\sigma}{4\epsilon_0}$$

Hence, half of the total intensity is due to the charge which lie within an inch of A (which are embraced in a right circular cone of semi-vertical angle 60°)

2.5 LINES OF FORCE

A line of force is defined as a curve indicating the direction in which a unit positive charge would travel. The tangent at any point of this curve gives the direction of the electrical force at that point.

The concept of lines of force had been used by Michael Faraday to represent E. This will help visualization of electric field patterns easily. This gives a vivid picture of the way that the electric field varies through a region of space. The number of lines per unit

2.6 ELECTRIC INDUCTION

Faraday gave a quantitative significance for the lines of force and tubes of force. The number of lines per unit area represent the intensity of the electrostatic field at a point in e.s units.

If 4π lines of force emanate from a unit charge, these lines are then called unit lines of induction. The number of lines of induction per unit area of a spherical surface of radius r is called the flux density. The flux density is given by

$$\frac{4\pi q}{4\pi r^2} = \frac{q}{r^2} = \kappa \frac{q}{\kappa r^2} = \kappa E$$

Lines representing E are lines of forces, but lines representing, κE are lines of induction
Total number of lines of induction that cut through a surface normally is called total normal electric induction or electric flux.

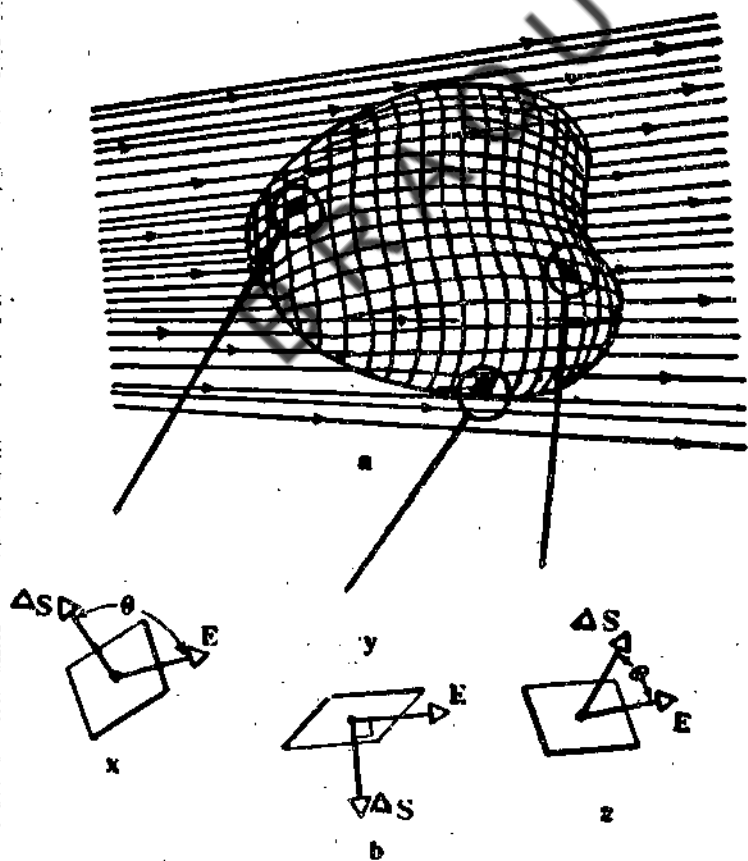

Fig 2.4 Electric flux over different surface elements

2.8. GAUSS THEOREM

Karl Friedrich Gauss (1777-1855), director of Göttingen observatory made outstanding contributions to astronomy, mathematics, electricity and magnetism. Gauss' theorem will enable us to determine the intensity of electric field at any point on a closed surface, if the charge inside the surface is known. Similarly the charges producing the field can be determined, if the charge inside the surface is known. Similarly the charges producing the field can be determined, if the intensity is known. Gauss' theorem states that, "the total normal electric induction (or flux) over a closed surface of any shape drawn in an electric field is 4π times the total charge (or the algebraic sum of the charges) within the surface.

Proof of the Theorem

A point charge of q coulombs is placed in a uniform isotropic medium of dielectric constant κ (Fig 2.5). Let E be the electric intensity at a point P directed outwards on the Closed Surface drawn around the charge q . If r is the distance of P directed from q .

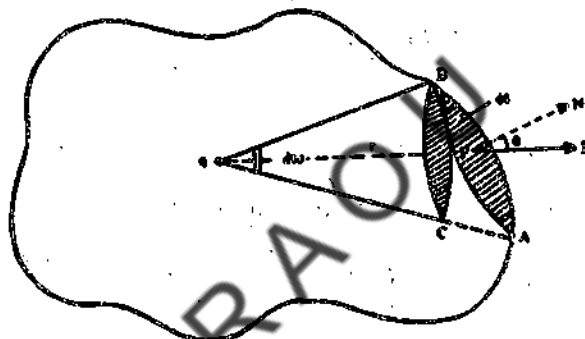

Fig 2.5 Gauss Theorem

$$\text{Then } E = \frac{q}{4\epsilon_0\kappa r^2}$$

Then, small elemental area 'ds'. Is surrounding the point P. The normal drawn to the surface the small elemental, area 'ds', is surrounding the point P. the normal drawn to the surface at P is making an angle θ with PE, E is the direction of electric field. So the normal component of E along PN is $E \cos \theta$

The normal electrical induction over elemental area 'ds' is

$$= \epsilon_0\kappa E \cos \theta ds = \epsilon_0\kappa \frac{q}{4\pi\epsilon_0\kappa r^2} \cos \theta ds = \frac{q ds \cos \theta}{4\pi r^2}$$

Coulomb's Law Derived from Gauss' Law

A second charge q_2 is put at a point P where E is to be calculated. The first charge q_1 is enclosed in the closed surface containing the point P . Then

$$\vec{F} = q_2 \vec{E}$$

$$\text{But } E = \frac{q_1}{\kappa r^2}; \text{ So, } F = \frac{q_1 q_2}{\kappa r^2} \quad \dots(2.5)$$

Eqn. (2.3) is nothing but Coulomb's law.

It may thus be noted that Gauss's Law and Coulomb's law are the same though expressed in a slightly different manner. Gauss' Law does not hold good if the law of force were inverse cube. Gauss' law gives a connection between field and its sources (charges). When Coulomb's law tells how to derive the electric field if the charges are known, Gauss' law gives a method of knowing the amount of charges present in the region, if the electric field is known.

Gauss' law is one of the fundamental equations of electromagnetic theory of Maxwell. Coulomb's law is not listed in that series of equations as it can be derived from Gauss' law.

2.9.1 Applications of Gauss' Law Intensity of Field of Uniformly Charged Sphere

(a) Consider a point P near, but outside a uniformly charged sphere A with a magnitude of charge q Coulombs. Let the radius of this sphere be R . Let the surrounding medium have a dielectric constant κ

Draw a concentric spherical Gaussian surface B about the charged sphere A so that it passes through P as shown in Fig 2.6

Now we have to find out the electric field intensity at the point P . The total surface area of this sphere = $4\pi r^2$ where r is the distance of P from the center of the charged sphere. Let E be the intensity of electric field at any point on this sphere. This will be the normal to the surface at every point on the surface.

The total normal electric induction = $\epsilon_0 \kappa E 4\pi r^2$ But the total normal electric induction. According to Gauss' Theorem is q

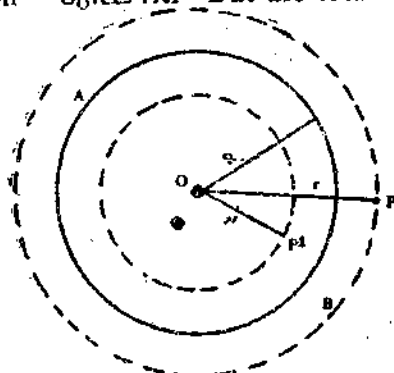

Fig 2.6 Intensity near a spherical conductor

$$E = \frac{q}{4\pi r^2} \quad \text{when } r > a$$

- (ii) Let $r < a$, then the 'Gaussian surface' encloses only $\rho \frac{4}{3} \pi r^3$ units of charge, where Gauss' flux theorem gives.

$$\epsilon \int \int_s E \cdot ds = \rho \frac{4}{3} \pi r^3 = \frac{Qr^3}{a^3}$$

$$\text{or } \epsilon E 4\pi r^2 = \frac{qr^3}{a^3} ; \text{ So, } E = \frac{qr^3}{4\pi \epsilon a^3}$$

2.10. SUMMARY

The region surrounding the charged material within which the influence of electric charges is felt on conductors is referred to as electric field. Electric field is a vector quantity and it is analogous to gravitational field. The distribution of electric field is indicated by the lines of force. The total normal electric induction, over a closed surface, in an electric field is 4π times the total charge within the surface.

Check your progress: Answers

1. $E = \frac{1}{4\pi \epsilon_0} \frac{q}{R^2}$

2. $E = q/Kr^2$ esu/cm.

3. Line of force is a curve indicating the direction in which a unit position charge would travel.

2.1 SAMPLE EXAMINATION QUESTIONS

I. Answer the following questions in detail

- 'State Gauss' Theorem? Discuss the application of Gauss' law to find the intensity of the electric field uniformly charged conducting sphere.
- Derive coulomb's law from Gauss' law. Discuss the application of uniformly charged non-conducting sphere.

UNIT – 3 ELECTRIC POTENTIAL

Contents

- 3.1 Objectives
- 3.2 Introduction
- 3.3 Electrical Potential
- 3.4 Equipotentials
- 3.5 Potential and field strength
- 3.6 Potential due to a point charge
- 3.7 Vector form of potential
- 3.8 Electric dipole
- 3.9 Electric field intensity and potential due to a dipole
- 3.10 Torque Experienced by a dipole.
- 3.11 The Electrostatic Generator
- 3.12 Summary
- 3.13 Sample Examination Questions

3.1 OBJECTIVES

This unit presents the concept of an electric potential. To help you understand the concept & the unit explains

- 1. Equipotential surfaces
- 2. Potential due to a point charge

After going through this unit you will be able to establish the potential due to a point charge, evaluate electric potential due to an electric dipole and describe the construction and working of van de Graaff generator.

3.2 INTRODUCTION

In this Unit we will discuss the concept of potential.

- 1. The concept about a dipole & torque as well
- 2. We will also learn about working principle of a Electrostatic generator.

An interesting special case of a spherically symmetric charge distribution in a uniform sphere of charge. This sphere is non-conducting. Such a uniform distribution of charge, occurs only in liquid or gaseous dielectrics.

The charge density $\rho = \frac{q}{\frac{4}{3} \pi r^3}$ where q is the charge, r is the radius of the sphere.

This is constant for all points within a sphere and would be zero for all points outside this sphere.

The total intensity E at a point P (Fig. 2.7) inside is obtained as if the charge were concentrated at the center.

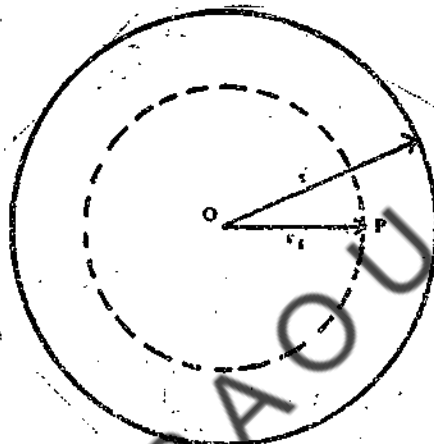

Fig.2.7 Concentric Gaussian surface

$$\epsilon_0 \kappa E \pi r_1^2 = \frac{4}{3} \pi r_1^3 \rho$$

$$\text{or } E = \frac{r_1 \rho}{3 \kappa \epsilon_0} = \frac{r_1}{3 \kappa \epsilon_0} \frac{q}{\frac{4}{3} \pi r^3}$$

$$= \frac{q r_1}{4 \pi \epsilon_0 r^2 \kappa}$$

$$\text{in CGS system, } E = \frac{q r_1}{\kappa r^3}$$

As the point P gets nearer to the center, the intensity of the field falls off to zero.

Worked Example -1: As an example, take Thomson atom model. The positive charges in the atom are assumed to be distributed uniformly through out a sphere of radius of about 1.0×10^{-10} m. Calculate the electric field intensity E , at the surface of gold atom ($Z=79$)

follows that the lines of force are those lines along which the force acts normal to the equipotential surfaces.

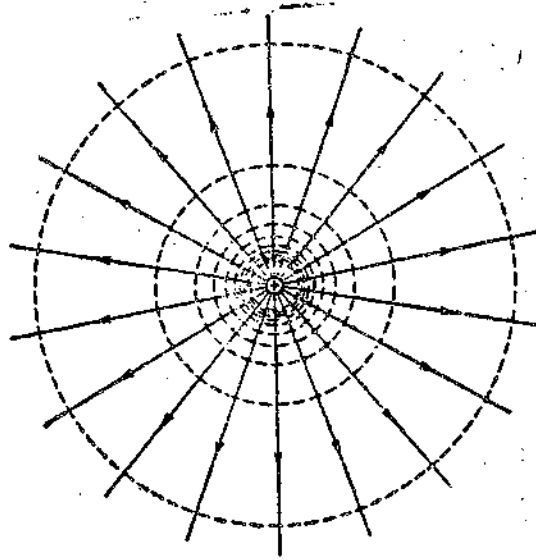

Fig 3.1 Equipotential surface

Lines of force always intersect equipotential surfaces perpendicularly, i.e the resultant electric intensity at any point is at right angles to the equipotential surface at the point(Fig 3.1) the existence of the lines of force and equipotential surface between charged bodies reveals a method of bringing a stream of moving charged particles to a point focus or of making them divergent (Fig3.2)

A_1, A_2, A_3 are three hollow metallic cylinders lying side by side. Let the potentials on A_1, A_2 and A_3 be 500, 2000 and 500 V respectively.

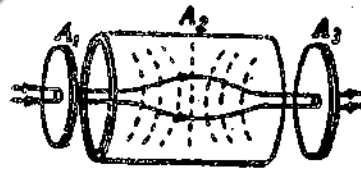

Fig 3.2 Electric lens

Then a beam of electron passing through A_1 will spread out in A_2 and then be directed through A_3 so as to move along curved lines of force. The dotted lines show the directions of equipotential surfaces. The electrons tend to move perpendicularly to the equipotential surfaces in the field in which they are traveling and this sort of arrangement of cylinders charged to different potentials forms an 'electric lens'. By keeping A_1 and A_2 at same voltage and by changing the voltage on A_2 the shape of the equipotential surfaces can be altered and the electrons can be brought to different "foci". The concept of an electric lens is very much used in the construction of cathode ray oscilloscope, electron diffraction unit, electron microscope etc.

3.5 POTENTIAL AND FIELD STRENGTH

Let A and B in Fig. 3.3 be two points in a uniform electric field E, set up by an arrangement of charges. Let A be a distance 'd' in the field direction from B. Assume that a positive test charge q_0 is moved without acceleration, by an external agent, from A to B along the straight line connecting them.

Fig 3.3. A test charge moving from A to B

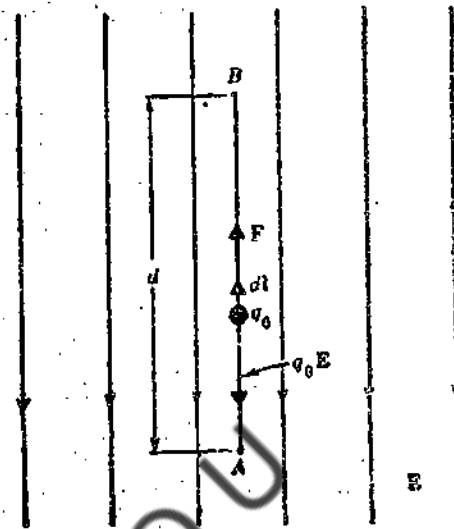

The electric force on the charge is $q_0 E$ and it points downwards. From the movement of charge in the fashion described above, this electric force must be counteracted by applying external force F of the same magnitude but directly opposite i.e., upwards. The work done W by the agent in supplying this force is.

$$W_{AB} = Fd = q_0 Ed$$

But Eqn. (3.1) tells that
$$\frac{W_{AB}}{q_0} = V_B - V_A \quad \dots(3.4)$$

So,
$$\frac{W_{AB}}{q_0} = (V_B - V_A) = Ed \quad \dots(3.5)$$

Eqn. (3.5) shows that the relation between the potential difference (pd) and the field strength for simple cases. From Eqn. (3.5), we get another MKS Unit for electric field as Volts/meter. But this unit is identical with Newton/Coulomb, Fig 3.3 could be caused to illustrate the act of lifting stone from A to B under the action of earth's gravitational field. This brings comparison between electrical field and gravitational field.

When the field is not uniform, and when the path of movement from A to B is not straight the work done can be computed over infinitesimally small line segments of the path dl and the total work done is obtained by integrating over the path length AB.

Thus
$$W_{AB} = \int_A^B F \cdot dl = -q_0 \int_A^B E \cdot d \quad \dots(3.6)$$

We get $V_B - V_A = \frac{q}{4\pi\epsilon_0} \int_{r_A}^{r_B} \frac{dr}{r^2}$... (3.10)

$(V_B - V_A) = \frac{Q}{4\pi\epsilon_0} \left(\frac{1}{r_B} - \frac{1}{r_A} \right)$ as $r_A \rightarrow \infty$... (3.11)

If A is chosen as a point at infinity (Where r_A) $V_A = 0$

The $V = \frac{1}{4\pi\epsilon_0} \frac{q}{r}$... (3.12)

If there are group of point charges, the potential is obtained by calculating the potential due to each individual charge ignoring the presence of other charges and compounding the sum. By this, the mutual repulsion (or attraction) among charges is neglected.

Then $V = \sum_n V_n = \frac{1}{4\pi\epsilon_0} \sum_n \frac{Q_n}{r_n}$... (3.13)

Q_n and r_n are the values of charge and distance of it from the point under consideration. The sum used to calculate V is the algebraic sum and vectorial sum. This is the computational advantage of potential over electric field strength.

Let the charge distribution be continuous. Then dq is the differential increase in charge and r is its distance from the point where V is calculated and dV is the potential it establishes at that point then.

$V = \int dV = \frac{1}{4\pi\epsilon_0} \int \frac{dq}{r}$... (3.14)

if ρ is charge density in the medium, then

$dq = \rho \cdot dv$ (dv is the volume element).

Then $V = \frac{1}{4\pi\epsilon_0} \int \frac{\rho dv}{r}$... (3.15)

In CGS units $V = \int \frac{\rho dv}{r}$... (3.15a)

Just as the electric intensity at a point in an electric field is the force per unit charge at that point, similarly the potential at a point is the potential energy per unit charge. Just as the energy is scalar quantity, potential is also a scalar quantity.

coincide the molecule is said to be non-polar: if the points are at a short distance apart, then the molecule is called a polar molecule, Water is a polar molecule while benzene is non-polar. The product of charge and distance between the positive and negative charges is called the dipole moment.

3.9 ELECTRIC FIELD INTENSITY AND POTENTIAL DUE TO A DIPOLE

Consider a dipole whose charges are $+q$ and $-q$ units separated by a distance $AB = 2l$ (l is of atomic dimensions) (fig. 3.5) The potential V at a point P , at a distance r from O , is given by

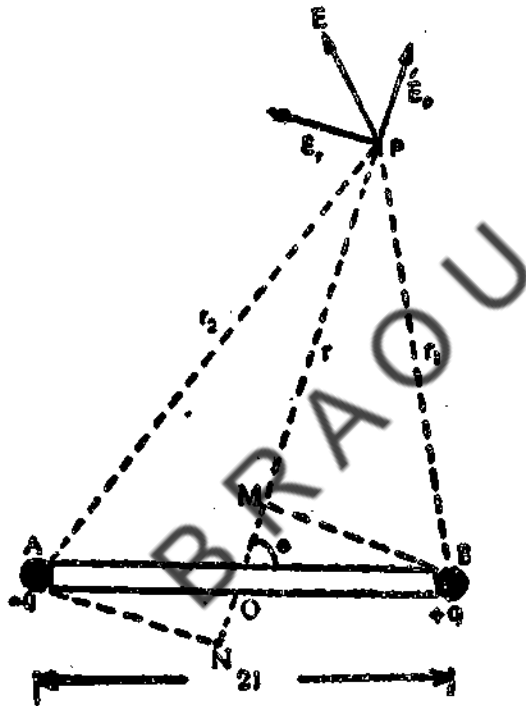

Fig 3.5 Electric dipole

$$V = \frac{1}{4\pi\epsilon_0} \left(\frac{q}{r_1} - \frac{q}{r_2} \right) \quad \dots (3.19)$$

$$\frac{1}{4\pi\epsilon_0} \left(\frac{q}{r - l\cos\theta} - \frac{q}{r + l\cos\theta} \right) \quad \dots (3.20)$$

$$\frac{2ql\cos\theta}{4\pi\epsilon_0(r^2 - l^2\cos^2\theta)} = \frac{2ql\cos\theta}{4\pi\epsilon_0 r^2} \quad \dots (\because l \ll r)$$

outer surface of the sphere, which would therefore be smooth and by applying a few hundred volts between A and earth. It can be raised to a few million volts.

A similar arrangement, with A connected to the negative end of the battery, of which the positive end is connected to earth, will enable the sphere to be charged negatively.

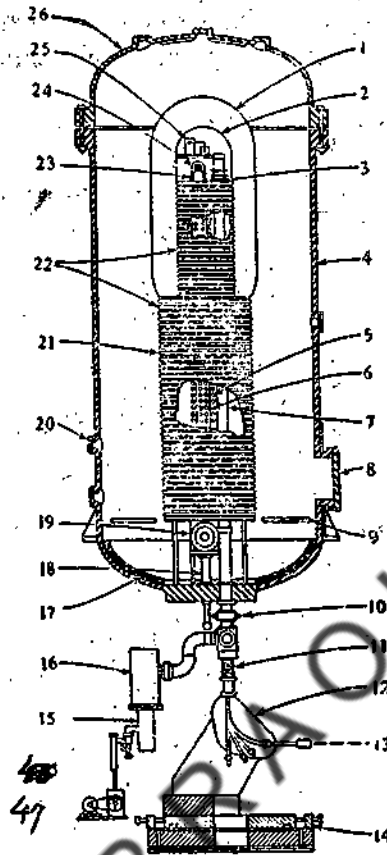

Fig 3.8 Van De Graff Generator

1. Equipotential shield
2. High voltage terminal
3. Positive iron source
4. Steel pressure tank
5. Field control rods
6. Insulating belt
7. Positive ion accelerating Tube
8. Manhole
9. Movable platform
10. Main valve
11. Flexible coupling
12. Analyzing magnet
13. beam axis
14. Adjustable magnet base
15. Pumping system
16. Dry ice trap
17. Lead shielding
18. Belt Tension Adjustment
19. 1,8000 run motors
20. Windows
21. Insulating column
22. Equipotential planes
23. Charge collector
24. Built - in Kw power supply
25. Electronic circuits
26. Removable tanks over.

Air surrounding the charged sphere is unable to with stand high potential; leakage starts when the air is at ordinary pressure. In order that there may not be any leakage, the generator is surrounded by a big metallic enclosure (which is earthed), is provided with two taps to allow air at high pressure 3.5 Kg to 7.0 Kg. Per sq. cm to be introduced into the space between the sphere and the belt and metallic tank. In a Van de Graff generator, constructed in 1947 at the Carnegie Institute, Washington the metallic tank has average

$$\text{Potential} = V = \frac{q}{4\pi\epsilon_0 r}$$

$$\frac{3.009 \times 10^{-8}}{4\pi \times 8.85 \times 10^{-12} \times 1.5 \times 10^{-2}}$$

$$1.803756 \times 10^4 \text{ Volts.}$$

$$18037.56 \text{ volts}$$

3.12 SUMMARY

Electrical potential at a point is the amount of work done against the field, in carrying a unit positive charge from infinity to the point. Electrical potential is similar to gravitational potential. The electric potential is a scalar quantity.

The electric intensity at a point in an electric field is the force per unit charge at that point. A pair of equal and opposite point charges separated by a distance is called a dipole.

Check your progress: Answers

I. 1. $V_B - V_A = W_{AB}/q$

II. 2. $\tan \lambda = P E \sin \theta$

3. Just as the electric intensity at a point in an electric field is the force /unit charge at that point. Similarly the Potential at a point is the PE/unit charge. Just as the energy is scalar quantity. Potential is also a scalar quantity.

1. Check your Progress: Answers

Positive potential is the potential near an isolated positive charge. It is positive because the work done to push the positive charge from infinity to the present position.

2. Check your progress: Answers

Electron volt is the amount of work done in moving it through a potential difference of one volt.

3.13 SAMPLE EXAMINATION QUESTIONS

1. Answer the following questions in detail

- 1 Show that the potential difference between two points is the line integral of the electric field between the two points.
- 2 Find the electric potential at a point, at a distance 'r', from a point charge q.
- 3 Show the $E = -\nabla v$
- 4 What is an electric dipole? Calculate the electric potential at a point due to a dipole. There by find the value of the electric field. What is the value of the field at a point. (i) on the axis of the dipole (ii) on the normal to the axis

3.10 TORQUE EXPERIENCED BY A DIPOLE

When an electric dipole (e.g. a hydrogen atom) is acted on by a uniform electric field of intensity E , it experiences a couple or torque given by $\tau = PE \sin \theta$.

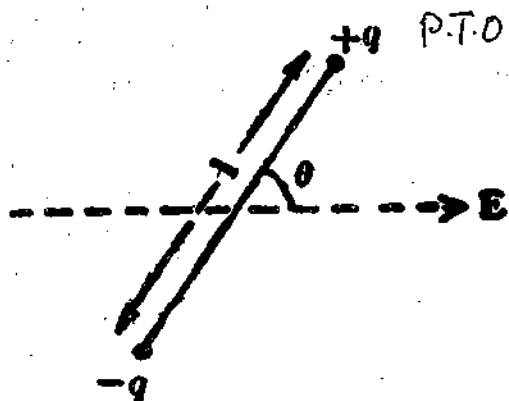

Fig 3.6 Torque due to a dipole

Where θ is the angle between the dipole axis and E [See Fig. 3.6]

The potential energy of the dipole is given by

$$P \cdot E = -PE \cos \theta = -q E \cos \theta$$

In vector notation, couple $= \vec{P} \times \vec{E}$... (3.27)

So far, we assumed that the electric field will not get distorted in the presence of uncharged conductor. In actual practice, there is distortion of the field produced because the amount of induced charge is not uniform. The distribution of induced charge on an uncharged conductor may readily be found by the method of electrical images devised by Lord Kelvin. This method also enables us to find the intensity and potential of a conductor when placed in an electric field.

In attempting to find the electrical image, the conditions to be satisfied are :

- (i) The potential of the conductor must remain the same.
- (ii) The potential at infinitely distant point must remain the same.
- (iii) The total normal induction over any closed surface in the original field must remain the same.

Check your progress – II

1. Torque experienced by a dipole is given by the expression.....
2. What is the similarity between intensity at a point in an electric field & Potential at a point. They are both..... quantities

Note: a. Space is given below for your answer

b. Compare your answers with those given at the end of the unit.

UNIT-4: CAPACITANCE

Contents

- 4.1 Objectives
- 4.2 Introduction
- 4.3 Capacitance
- 4.4 Energy stored in the field of a charged capacitor
- 4.5 Combination of capacitors
 - 4.5.1 Capacitors in parallel
 - 4.5.2 Capacitors in series
- 4.6. Capacitance of conductor
 - 4.6.1 An Isolated sphere
 - 4.6.2 Two concentric spheres
 - 4.6.3 Capacity of cylindrical condenser – Submarine Cable
 - 4.6.4 Cylindrical sliding condenser
- 4.7 Summary
- 4.8 Sample Examination Questions

4.1 OBJECTIVES

This unit discusses the concept of capacitance and its relation to storage of electrical charges and voltage. To help you understand the concepts, this unit explains the conditions required for the storage of energy in a charged condenser.

After going through this unit you will be able to (1) calculate the effective capacitance in the series and parallel connections of capacitances (2) the capacitance of isolated sphere, and(3) concentric spheres and cylindrical condensers.

4.2 INTRODUCTION

In this Unit we will discuss the concept of capacitance and its relation to storage of electrical charges and voltage. We will also study the effective capacitance when they are connected in series and parallel.

Thus 1 Farad = 1 Coul./Volt

$$1 \text{ Farad} = \frac{3 \times 10^9 \text{ e.s units of charge}}{1.300 \text{ e.s. units of potential}}$$
$$= 9 \times 10^{11} \text{ e.s units of capacitance.}$$

Since the Farad is too big a unit, a microfarad $1 \mu\text{F} = 10^{-6}$ Farads) and a Pico farad or micro farad ($1 \mu\mu\text{F} = 1 \text{pF} = 10^{-12}$ Farads) are used in practice.

The *e.s units of capacitance* is however defined as the capacity of a body whose potential is raised to 1 esu or by 1 e.s unit of charge.

In the medium of dielectric constant K , the potential V of a charge body becomes V^1/K . So the capacitance will, then be KC^1 . (V^1 and C^1 refer to vacuum).

An analogy can be made between a capacitor carrying charge q and a rigid container of volume V containing μ moles of ideal gas

$$\text{According to ideal gas law } \mu = \left(\frac{pV}{RT} \right) P$$

$$\text{For a capacitor } q = (C) V \quad \dots (4.5)$$

Thus the capacitance is analogous to the volume of the container at a particular temperature. Just as any amount of charge can be put on a capacitor, so any amount of gas can be filled in a container (upto certain limits). If the charge exceeds a critical value, breakdown of capacitance occurs. If the mass of gas exceeds a critical limit, rupture of container walls occurs.

If two conductors (of equal and opposite charges) of any shape are brought near a distance apart, that assembly of conductors is called a capacitor condenser. The conductors are called the plates. The capacitance of a capacitor depends on (a) the geometry of each plate, (b) their spatial relationship with respect to each other and (c) the medium in which they are immersed. The capacitors are generally represented by the symbol, " $\text{—} | \quad | \text{—}$ "

The capacitors are very useful devices, and are of greater interest to physicists and engineers. For example, (1) the capacitors are used to deflect electron beams. (2) They are used to store electrical energy since they can confine strong electric fields to small volumes. (3) There could not have been a progress in the field of electronics and modern communication engineering without the capacitors. They are used in (a) filtering the electrical fluctuations, (b) transmitting pulsed signals and (c) generating or detecting radio frequency waves and so many other functions.

4.4 ENERGY STORED IN THE FIELD OF A CHARGED CAPACITOR

The energy of a charged capacitor is equal to the work done in charging it. Suppose the potential difference between the plates at any instant of time is V , the work done (dW) in bringing a small charge, dq to the capacitor, when its potential is V , is given by $dW = V \cdot dq$.

The total charge on the combination is

$$q = q_1 + q_2 + q_3 = (C_1 + C_2 + C_3) V$$

The equivalent capacitance C is $= \frac{q}{V} = (C_1 + C_2 + C_3)$

$$\text{Thus } C_{\text{eff}} = C_1 + C_2 + C_3 \quad \dots (4.9)$$

This result is extendable to any number of capacitors connected in parallel.

4.5.2 Capacitor in Series

Fig. 4.2 shows three capacitors connected in series.

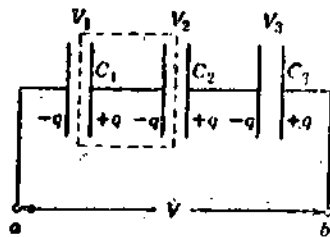

Fig. 4.2 Three capacitors connected in series.

To find the equivalent capacitance C , we proceed in the following way. In the connection shown fig 4.2, the charge q on each plate must be the same. This is because of the reason that the net charge present initially on these plates is zero. Connecting the plates to a battery will only produce a charge separation keeping the net charge on these plates zero. Assuming that neither C_1 nor C_2 'sparks over', no charge can enter from outside or leave the region enclosed by dashed line.

Since $q = CV$,

$$V_1 = \frac{q}{C^1} ; V_2 = \frac{q}{C^2} \text{ and } V_3 = \frac{q}{C^3} \quad (4.10)$$

The potential difference for the combination series is

$$V = V_1 + V_2 + V_3$$

$$= q (1/C_1 + 1/C_2 + 1/C_3)$$

But $V = q/C$

The equivalent capacitance

$$\frac{1}{C_{\text{eff}}} = \frac{1}{C_1} + \frac{1}{C_2} + \frac{1}{C_3}$$

The equivalent capacitance is always less than the smallest capacitance in the chain. The

If the two spheres are surrounded by air, $k=1$

$$\epsilon_0 = 8.85 \times 10^{12} \text{ Farad/m}$$

$$\text{In CGS units, } C = \frac{ab}{(b-a)} \text{ esu} \quad \dots(4.13)$$

By surrounding A with an earthed conductor, the capacity of A is increased. In CGS units C_{ac} be written as

$$C = \frac{a}{(1-a/b)} \text{ esu} \quad \dots(4.14)$$

If $b \rightarrow \infty$, then $C = a = \text{radius of the inner sphere}$. Thus the charged sphere can be regarded as a condenser in which outer coating has been removed to an infinite distance.

In fact every charged conductor possesses some capacity. Ordinarily a wire has too little surface area to have much capacity. However, the wires of long telephone and power lines have sufficient capacity to act as condensers.

By bringing a charged conductor in the neighborhood of an earthed conductor, the potential of the former is lowered and therefore its capacity or capacitance increases. In order to maintain the potential on the charged conductor (near the earthed conductor), we must give extra charge to it.

A useful property of a condenser is that when it is placed in a direct (DC) circuit, it does not allow steady current of flow through it. A condenser used for such purpose is called a blocking condenser. Its behavior in an alternating current is altogether different.

4.6.3 Capacity of Cylindrical Condenser – Submarine Cable

A metal cylinder is placed coaxially inside a hollow metallic cylinder of large radius. The space between the cylinders is filled with a dielectric of dielectric constant K . Then we get a cylindrical condenser. A submarine cable is a practical example of such condenser. In a submarine cable, the inner conductor is a copper cable and the seawater is the outer-earthed cylinder. The insulating sheath (of polystyrene) forms the dielectric. Let a and b be the radii of the inner and outer cylinders (or the inner and outer edges of the dielectric) respectively. (K is the dielectric constant).

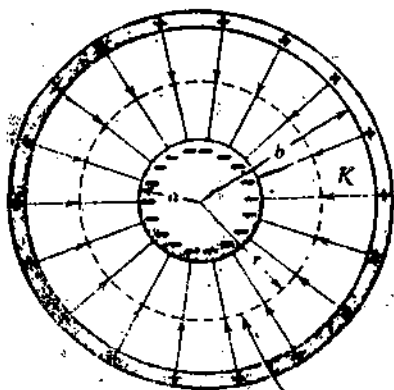
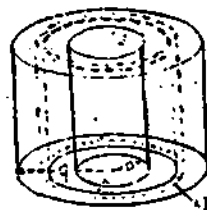

Fig 4.4 Cylindrical condenser



1. Gaussian surface

Between them. One of these cylinders is earthed. C carries an inner metallic cylinder B, which is also coaxial with the outer. It can be moved axially in and out of A by means of a micrometer screw fixed on C. This screw allows the length of B inside A to be accurately measured.

The cylinder A is usually surrounded by another earthed cylinder to prevent the leakage of charge to outside bodies. B and C are first earthed. A is insulated and is given a charge. When B is moved into A by a distance l , the change in capacity of A is given by

$$\frac{2\pi\epsilon_0 k l}{2.303 \log_{10}(b/a)}$$

Where a and b are the radii of A and B respectively.

Thus if its capacity for a particular setting of micrometer is measured by comparison with a standard condenser, its change in capacity is found with the help of the above expression. Then this condenser can be used for measuring the capacitance of any other unknown condenser.

Example -1:

The parallel plates of an air-filled capacitor are everywhere 1.5 mm apart. What must be the plate area if the capacitance were to be 1.5 farads

Solution:

$$C = \frac{q}{V} = \frac{\epsilon_0 EA}{Ed} = \frac{\epsilon_0 A}{d}$$

$$\text{or } A = \frac{Cd}{\epsilon_0} = \frac{1.5 \times 10^{-3} \text{ m} \times 1.5 \text{ Farad}}{8.9 \times 10^{-12} \text{ Coul/J.m}^2}$$

$$A = 2.532 \times 10^8 \text{ m}^2$$

Example-2:

A capacitor C_1 is charged to a potential difference V_0 . The charging battery is then removed and the capacitor is connected, as shown in figure to an uncharged capacitor C_2 . Find the potential difference V across the combination.

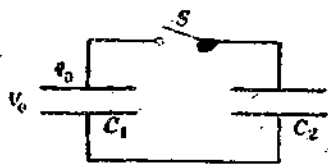

Fig 4.6

3. Energy stored in the field of a charged condenser; and also describe the construction, working and the uses of various types of condensers.
4. The effect of dielectric media on the capacity of a condenser;
5. The dielectric behavior from the atomic view point.

5.2 INTRODUCTION

In this unit we will evaluate the capacity of a parallel plate condenser and the dielectric Constant, and discuss the influence of dielectric media on the capacity of a condensers. Also study about the amount of energy stored in a condenser.

Study dielectricity from atomic point of view. Know about variable, Fixed and Guard -ring condensers, Also study about the amount of energy stored in a Condenser.

5.3 PARALLEL PLATE CONDENSER

The concept of capacitance and potential were discussed in previous units. We shall now discuss the capacity of a parallel plate condenser.

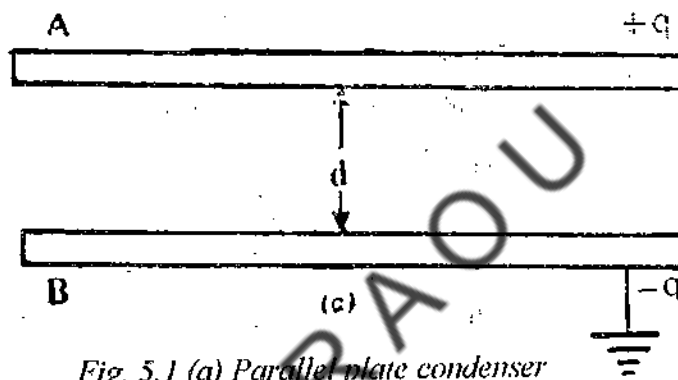

Fig. 5.1 (a) Parallel plate condenser

A parallel plate condenser consists of two metal plates usually in rectangular form separated by a Dielectric. If the plates A and B, shown in fig 5.1 a, are further apart, the tubes of force at the end will be curved owing to lateral pressure and they will not be of constant cross sectional area nor are they equally spaced. However, as an approximation we assume that the plates are near enough so that the lines of forces are straight throughout the space A and B, E and electric field intensity between the plates is also assumed to be uniform.

The plates are of area A sq. m and given a charge of + q Coulombs. B is earthed. (earthing means that the plate is connected to earth and is maintained at zero potential. Usually earthing is indicated symbolically as shown above. d is the distance between the plates in meters and K is the dielectric constant of the medium, where in the condenser is placed.

The potential difference between A and B is V Joules /coul.

$$-V = \int_d^0 \vec{E} \cdot d\vec{r} = \int_d^0 \frac{\sigma dr}{\epsilon_0 K} = \frac{\sigma}{\epsilon_0 K} \dots (5.1)$$

Is called 'stator'. The second set is called 'rotor'. Such type of condensers are used very much in various fields of electronics whenever the variation of capacity leading to change in frequency is needed. This is used in radio communications, televisions, Etc.

5.4.2 Fixed condensers

Fixed condensers of fixed capacity are however made in the form of parallel plate condensers, consisting of very thin layers of metal coated on to the surface of mica or paper, impregnated with paraffin, as the dielectric between them. The papers will then be rolled up to occupy less space. A number of condensers can be piled up in parallel, with the alternate foils fixed to one end each, to yield a large capacity. Such fixed condensers are sometimes arranged in boxes.

Ceramic materials are now-a-days used as low loss dielectric at all frequencies.

Electrolytic condensers are generally used to obtain large capacity although the dimensions of the condensers are small.

5.4.3 Guard - Ring Standard Condensers

The capacity of parallel condenser is given by $c = \left(\frac{\epsilon_0 A}{d} \right)$ but it has been assumed that

the electric intensity between the two parallel plates remains the same throughout the area of the plates. Since the field of force and hence the intensity at the edges is not uniform the above formula is only approximate.

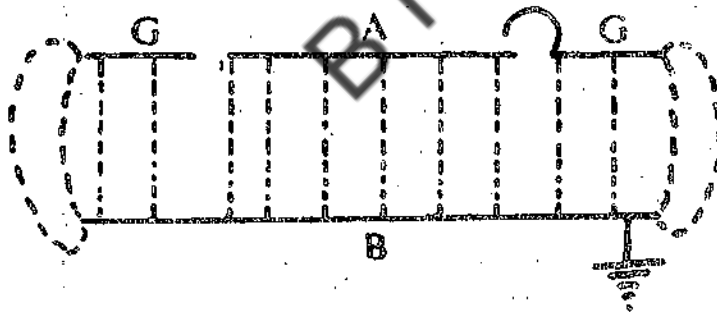

Fig 5.3 Guard ring condenser

The end effects were overcome by Lord Kelvin by using a circular plate surrounded by a ring G in the same place as the inner plate (Fig 5.3). The area of B = the area of A + G together. To start with, B is earthed. A and G are kept at same potential by means of conducting wire (between A and G) and the wire is then tilted over to G. Field between A and B is then uniform.

a) Effective area of a plate = A^1 = area of plate A = area of gap

$$\text{Then } C = \frac{A^1 \epsilon_0}{D} \quad \dots (5.14)$$

The distance between the plates can be altered by using micrometer fixed to B.

III. Solve the following problems

1. A parallel plate condenser has circular plates of 8.0 cms radius and 1 mm separation. What quantity of charge will appear on the plates if a potential difference of 100 V is applied?
2. Find the capacity of a condenser consisting of a sphere and a concentric spherical shell of radii 9cm and 10 cm respectively separated by air.

Find the potential of the sphere if it is given a charge of 13.3×10^{-9} Coulombs, while the outer shell (i) insulated (ii) earthed.

(Ans: 3×10^{-8} Coul; 1.48×10^{-9} Coul. And 0.48×10^{-9})

3. Sphere of radius 10 cms is charged to a potential of 3.33×10^9 Coulombs. One sq. mm of gold leaf spread on the surface of the sphere is removed to a point 20cms from the sphere. What is the work done?

(Ans 5.3×10^{-10} Joules)

4. A cable has a copper core of 4 mm radius. This is surrounded by one layer of insulating material and the inner layer has a thickness of 5 mm and dielectric constant 3.5. Find the capacity of 1-cm length of the cable.

(Ans: 100CGS units)

5. Two capacitors (2.0μ and 4.0μ F) are connected in parallel across a 3600 V potential difference. Calculate the total stored energy in the system.

(Ans: 0.27 Joules)

6. Find the equivalent capacitance of the combination given in Fig II.1 and determine the charge on each capacitor.

Fig. II-1

- (i) $C_1 = 10 \mu$ F, $C_2 = 5 \mu$ F, $C_3 = 4 \mu$ F and $V = 100$ V.

(Ans: 7.33μ F; $q_1 = q_2 = 333 \mu$ C; $q_3 = 100 \mu$ C)

- (ii) $C_1 = 5 \mu$ F, $C_2 = 4 \mu$ F, $C = 1 \mu$ F and $V = 100$ V.

(Ans: 3.22μ F; $q_1 = q_2 = 222 \mu$ C; $q_3 = 100 \mu$ C)

where q is the free charge.

$$\text{But } V = - \int E \cdot dr = Ed \quad \dots (5.5)$$

$$\text{So, } C = q/V = \frac{\epsilon_0 k A E}{Ed} \quad \text{Farads} \quad \dots (5.6)$$

$$\text{In CGS system } C = \frac{kA}{4\pi d} \quad \text{CGS units} \quad \dots (5.7)$$

The effect of introducing an insulated uncharged conductor between the plates of an air condenser is merely to reduce the extent of the field between the plates of the condenser. The separation between the plates is shown in Fig 5.1c. There can be no field inside. Hence potential difference (pd)

$$= \frac{\sigma d_1}{\epsilon_0} + \frac{\sigma(d-d_1-t)}{\epsilon_0}$$

$$D = \frac{\sigma}{\epsilon_0} (d-t) \quad \dots (5.8)$$

$$\text{Capacity} = \frac{\epsilon_0 A \sigma}{\sigma(d-t)} = \frac{\epsilon_0 A}{(d-t)} \quad \dots (5.9)$$

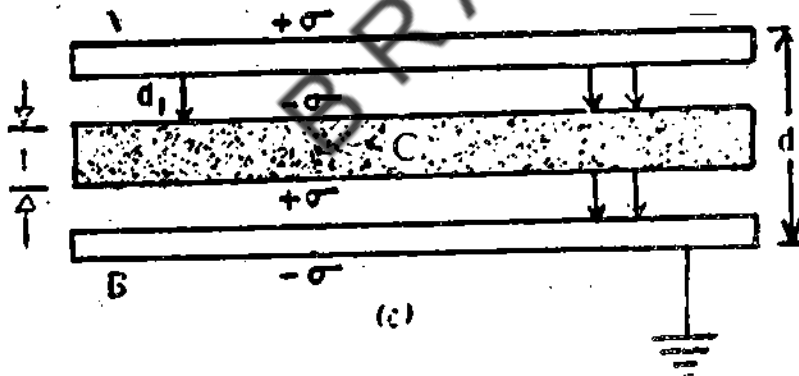

Fig 5.1 (c) Electric field in a parallel plate condenser

Charge in capacitance due to introduction of conductor

$$C = \frac{\epsilon_0 A}{(d-t)} - \frac{\epsilon_0 A}{d} = \frac{\epsilon_0 A t}{d(d-t)} \quad \dots (5.10)$$

If the dimension of the plates and dielectric are given in cms, the capacity will be in esu which may be converted into micro farads by dividing by 9×10^5 . Thus the capacity of a parallel plate condenser, with dielectric of constant K filling the space is

There are two cases:

(a) When the charges Remain the Same

Mechanical force or force of attraction per unit area between inside surface of each plate is equal to the outward electrical pressure over unit area of surface of A. It is given by

$$F = \frac{\sigma^2}{2 \epsilon_0 \kappa} = \frac{d^2}{2 \epsilon_0 \kappa A^2} \text{ N/m}^2$$

Where σ is the surface density of charge on A. Therefore the force of attraction between A and B, each area a sq .m = $\frac{d^2}{2 \epsilon_0 \kappa A}$ N: and the work done is separating the plates

by a distance d is given by $W = \text{force} \times \text{distance} = \frac{q^2 d}{2 \epsilon_0 \kappa A}$ Joules.

$$\text{So, } W = \frac{q^2 d}{2 \epsilon_0 \kappa A} \quad \dots (5.15)$$

If $\kappa = 1$, force of attraction = $\frac{q^2 d}{2 \epsilon_0 a}$ N. Thus when the charge remains same, the force of

attraction between the plates with a medium having ' κ ' as dielectric constant is $(1/K)$ times the force with air as dielectric.

Since the generally measured parameter is the potential on the plates and not the charge, the expression for the force of attraction is more useful when expressed in terms of the potential difference between the plates instead of charge.

(b) When the potential difference between the plates remains the same.

When both plates are connected to the two ends of a battery, i.e., positive end to A and negative end to B. (Fig 5.1c)

Since $q = CV = \frac{\epsilon_0 \kappa A}{d} V$ and $F = \frac{q^2}{2 \kappa \epsilon_0 A^2}$ the force of attraction per square meter.

$$F = \frac{(\kappa \epsilon_0 A \cdot V/D)^2}{2 \kappa \epsilon_0 A^2} = \frac{\kappa \epsilon_0 V^2}{2 d^2} \text{ N/m}^2 \quad \dots (5.16)$$

It shows that if V remains constant, the force of attraction is directly proportional to K, i.e., the force on a dielectric medium is K times that with air as dielectric

Hence the total work done by charge q is

$$W = \int_0^q V dq \text{ Joules} \quad \dots (5.21)$$

But V is not constant. It is function of q . So,

$$W = \int_0^q q/cd dq = \frac{q^2}{2c} = \frac{1}{2} qv = \frac{1}{2} CV^2 \quad \dots (5.22)$$

This eqn *5.22) represents the energy stored in charged condenser. W will be in Joules if q is in coulombs, C in Farads and V in volts.

For a parallel plate condenser having the surface density σ , area of insulated plate A , and the distance between the plates, d , the energy is given by

$$\text{Energy} = \frac{1}{2} q^2 c = \frac{1}{2A^2 \sigma^2} \frac{\delta}{\kappa A \sigma} = \frac{\sigma^2 (Ad)}{2\kappa \epsilon_0} \quad \dots (5.23)$$

$$\text{and energy density} = \frac{\sigma^2}{2\kappa \epsilon_0} \quad \dots (5.24)$$

Thus the energy of a parallel plate condenser is the same as the mechanical work done in separating the plates. This energy resides in or is stored up in the dielectrics. This energy can easily be demonstrated with a Leyden jar of detachable parts. The energy so stored up is equal to $\frac{1}{2} \kappa \epsilon_0 E^2$ Joules/m, of the dielectric. This is also the energy of a charged conductor, as this and the surrounding walls, with air as dielectrics form a condenser.

If the potential (V) is the same for both conductors (one having κ , as dielectric) constant and the other with air), the conductor with dielectric will have an energy κ times that of the conductor surrounded by air. This is true for any conductor or condenser.

Let the plates be connected to the ends of a battery and charged to $+q$ and $-q$ respectively. If the battery is now removed so that the charge remains the same, and the dielectric (of dielectric constant) is introduced between the plates, the potential is reduced to $1/\kappa$ and the energy $q^2/2c$ is also reduced in the same ratio (of $1/\kappa$). The energy which has disappeared has been used in inserting the dielectric. If on the other hand, the battery connection is retained and the dielectric is introduced (so that the potential remains constant), the charge and hence the energy are increased κ times to their initial values. The extra energy is supplied by battery. When the dielectric is introduced partially in between the plates of a condenser the energy tends to a position of minimum energy and hence the dielectric will be drawn or sucked into the plates.

Thus two similar conductors of different materials, charged to the same potential, will have their charges and energies directly proportional to their dielectric constants.

$$\text{Energy after contact} = \frac{1}{2} \frac{q^2}{C} = \frac{(0.0315)^2}{2 \times 30 \times 10^{-6}}$$

$$= 16.54 \text{ Joules}$$

So loss of energy = 6.07 Joules

$$\text{Common potential} = \frac{q^2}{C} = \frac{0.0315}{30 \times 10^{-6}} = 1050 \text{ V}$$

Example - 5 :

Assuming the earth of radius 6.4×10^6 m to be a charged sphere in free space and with an electric field of 300 V/m at its surface, find the energy of its charge, and the heat generated if it were completely discharged.

Electric intensity = 300 V/m

$$\therefore \text{charge is given from Eqn. (5.4) for } E = \frac{\sigma}{\epsilon_0} = \frac{Q}{A\epsilon_0}$$

$$\text{So, } 300 = \frac{q}{4\pi (6.4 \times 10^6)^2 \epsilon_0}$$

$$\text{or } q = 4\pi (300) (6.4 \times 10^6)^2 \epsilon_0$$

$$= \frac{q^2}{2C} = \frac{(4\pi)^2 (300)^2 (6.4 \times 10^6)^4 \epsilon_0^2}{2 \times 4 \pi \epsilon_0 (6.4 \times 10^6)}$$

$$= 2 \pi (300)^2 (6.4 \times 10^6) \epsilon_0$$

$$= 1.31 \times 10^{15} \text{ joules}$$

$$\text{Heat produced} = \frac{1.31 \times 10^{15}}{4.2} = 3.12 \times 10^{14} \text{ cal.}$$

Example - 6:

The intensity of electric field due to a spherical conductor of diameter 4 cms at a distance of 20 cms from its center is 30 V/cm. Calculate the energy of the conductor.

SOLUTION:

$$E = 3000 \text{ V/m}$$

$$C = 4\pi\epsilon_0 (0.02); \text{ V at } 20 \text{ cm} = \frac{q}{4\pi\epsilon_0 (0.02)}$$

$$V = E \cdot d = \frac{q}{d} \quad \text{or } q = 4\pi\epsilon_0 (0.02) 3000 (0.02)$$

The induced surface charge will always appear in such a way that the electric field due to them E^1 opposes external electric field (E_o). The resultant field E is $E_o + E^1$. E^1 is in the same direction as E_o , but is smaller. Thus the induced surface charge in a dielectric due to external field, will always tend to weaken the original field within the dielectric. This weakening of the electric field reveals itself as a reduction in potential difference between the plates of a charged isolated capacitor when a dielectric is introduced between the plates. More specifically, if a dielectric slab is introduced into a charged parallel-plate condenser, then

$$\frac{E_o}{E} = \frac{V_o}{V_d} = k \quad \dots(5.26)$$

Induced electric surface charge is the explanation of the most elementary fact of static electricity. A dielectric body in a uniform electric field will not experience a net force

5.7 DIELECTRIC CONSTANT

The dielectric constant ϵ_r or relative permittivity depends upon the temperature, pressure and crystalline state. It plays an important role in electrostatic phenomenon. It has a much higher value for solids and liquids than for air. The dielectric constant of the material may also be defined as the ratio of the capacitance with dielectric (C^1) (inserted in between the plates of a parallel plate condenser) to that without the dielectric (C). Tables 5.1 give the properties of some dielectrics.

Variation of dielectric constant

The dielectric constant of the material depends not only on its purity but also upon factors such as temperature. Frequency of the applied voltage, humidity etc. Dielectric constant for solids increases with raise in temperature while for liquids, it decreases with increases in temperature.

Table 5.1 Properties of some dielectrics

Substance	Dielectric Constant k	Dielectric Strength* (kv/mm)	Substance	Dielectric Constant k	Dielectric Strength* (kv/mm)
Flint	5.0		Vacuum	1.00.000	α
Crown glass	8.9		Paper	3.3	14
Sulphur	2.4		Porcelain	6.5	4
Ebonite	3.2		Fused quartz	3.8	8
Paraffin	4.0		Bakelite	4.8	12
Rubber	2.2		Polyethylene	2.3	50
Mica	4.6		Polystyrene	2.6	25
Acetone	21.0		Teflon(PTFE)	2.1	60
Ethylalcohol	26.0		Neoprene	6.9	12
Distilled water	70		TiO ₂	100	6

Where q represents only free charge, the induced surface charges being excluded. Table 5.2 gives the properties of electric vectors D , E and P .

Table 5.2 Three Electric Vectors

Name	Symbol	Associated with	Boundary Condition
Electric field strength	E	All charges	Tangential component continues
Electric displacement	D	Free charges only	Normal component Continues.
Polarization	P	Polarization charges Only	Vanishes in vacuum
Defining equation For E	$\vec{F} = q \vec{E}$		
General relations among the three vectors		$\vec{D} = \epsilon_0 \vec{E} + \vec{P}$	
Gauss' law when dielectric media are present		$\oint \vec{D} \cdot d\vec{s} = q$ (q , free charge only)	
Empirical relations for certain Dielectric materials		$\vec{D} = k\epsilon_0 \vec{E}$ $\vec{P} = (k-1)\epsilon_0 \vec{E}$	

Uniform dielectric

A description of a dielectric at an atomic level and the surface charges induced on account of incident external field is given in earlier section. Also the variation of potential and the electric field intensity are also discussed earlier. The variation in capacity as well as potential and other parameters such as electric displacement D , as a result of introducing a uniform dielectric medium like glass is also discussed earlier.

We shall now discuss how the capacity, charge, potential difference, electric field intensity and displacement will be affected when the space in between the parallel plate condenser is filled with compound dielectric.

5.10 CAPACITANCE OF PARALLEL PLATE CONDENSER WITH A COMPOUND DIELECTRIC

On the introduction of dielectric in the space between the plates of a condenser, there is a change in the potential difference between A and B (Fig 5.7). For calculating the potential difference between A and B, we use the expression $V = \int \vec{E} \cdot d\vec{r}$ for air and for dielectric.

5.9 ELECTRIC DISPLACEMENT, ELECTRIC POLARIZATION AND ELECTRIC FIELD.

For simple problems in electromagnetism such as rectangular slab placed at right angles to uniform electric field, the treatment of dielectric presented in earlier lesson is sufficient. For treatment of more complex problems – such as finding E in a dielectric placed in a non uniform external electric field, a new formation presented below is necessary.

The induced surface charge per unit area of the surface is called electric polarisation.

$$P = (q_0 / A) \quad \dots (5.31)$$

The name 'polarisation' is suitable because the induced surface charge q' appears when the dielectric is polarised. The electric polarisation, P can be defined in an equivalent way by multiplying both numerator and denominator by d, the thickness of dielectric slab.

$$P = (q' / Ad) \quad \dots (5.31a)$$

$q' d$ gives the induced electric dipole moment where as Ad gives the volume of the slab. So electric polarization can also be defined as the induced electric dipole moment per unit volume in the dielectric. This suggests that P should be a vector quantity since the induced dipole moment is also a vector. The direction of P is from the negative induced charge to the positive induced charge.

If q and q' are the free and induced charges on the plates respectively. 'A' is the area of the plates, they are related by the equation.

$$\frac{q}{A} = \epsilon_0 \frac{q}{(\kappa \epsilon_0 A)} + \frac{q'}{A} \quad \dots (5.32)$$

We can rewrite this equation as

$$\frac{q}{A} = \epsilon_0 \vec{E} + P \quad \dots (5.33)$$

The quantity on the right hand side of Eqn. (5.33) occurs so often in electrostatic problems, we give it the special name 'electric displacement', D:

$$\text{So } \vec{D} = \epsilon_0 \vec{E} + \vec{P} \quad \dots (5.34)$$

$$\text{Where } D = q/a \quad \dots (5.35)$$

Since E and P are vectors, D must also be a vector.

In more complicated problems, however, D, E and P may vary both in magnitude and direction from point to point. From the definitions. We observe the following aspects.

In general if there are numbers of dielectrics with dielectric constants κ_1, κ_2 and or thickness t_1, t_2, \dots respectively and are placed in between the plates of parallel plate condenser, we have p.d.

$$= \frac{\sigma}{\epsilon_0} \left[d - (t_1 + t_2 + \dots) + \frac{t_1}{\kappa_1} + \frac{t_2}{\kappa_2} + \dots \right] \quad \text{and the} \quad \dots (5.47)$$

$$\text{Capacitance } C = \left[\frac{A\epsilon_0}{\left(d - \frac{t_1(\kappa_1 - 1)}{\kappa_1} - \frac{t_2(\kappa_2 - 1)}{\kappa_2} - \dots \right)} \right] \quad \dots (5.47)$$

$$\text{or } C = \left[\frac{A\epsilon_0}{\frac{t_1}{\kappa_1} + \frac{t_2}{\kappa_2} + \frac{t_3}{\kappa_3} + \dots} \right] \quad \dots (5.48)$$

Eqn. 5.47 applies when $d < [t_1 + t_2 + t_3 + \dots]$ and

Eqn. (5.48) applies if there are various dielectrics in place of air

But there will arise another case when dielectric is partly inside the plates A and B and partly outside. [Fig. 5.7 (b)]

Then the capacity can be worked out on the following lines.

Let A_1 and A_2 be the areas occupied by air above and the dielectric between A and B respectively. If we assume that the tubes of force in air are straight except at the edges of the plates and the dielectric.

$$D = \frac{A_2\epsilon_0}{\left[\frac{d - (\kappa - 1)E}{\kappa} \right]} + \frac{A_1\epsilon_0}{d} \quad \dots (5.49)$$

Thus if A_1 is decreased, C (i.e., capacitance) decreases.

$$\text{If } t = d \text{ [Fig. 5.7(6)], } C = \frac{\kappa A_2\epsilon_0}{d} + \frac{A_1\epsilon_0}{d} \quad \dots (5.50)$$

Also if 'l' is the length of the plate and 'x' is the length of the dielectric inside, and A is the area of the whole plate, then

$$\frac{A_1}{A_2} = \frac{(l-x)}{l} \quad \text{and } A_1 + A_2 = A$$

$$\text{And } A_1 = \frac{l-x}{l} A; \quad A_2 = \frac{x}{l} A$$

$$E = \frac{\sigma l}{\kappa \epsilon_0} = \frac{8.9 \times 10^{-5} = 2.0 \times 10^6 \text{ Volt/m}}{5 \times 8.9 \times 10^{-12}}$$

$$D = \epsilon_0 \kappa E = \frac{5 \times 8.9 \times 10^{-5} \times 8.9 \times 10^{-12}}{5 \times 8.9 \times 10^{-12}} \text{ Volts/m}$$

$$\text{p.d } E^1 d = 2 \times 10^6 \times 0.5 \times 10^{-2} = 1 \times 10^4 \text{ Volt}$$

Example - 2:

A dielectric slab of thickness 0.5 cm and dielectric constant 7.0 is placed between the plates of parallel plate condenser of plate of area 100 cm² and separation 1.0 cm (A) p.d. of 100 V is applied without the dielectric. Calculate the capacitance C₀ before the slab is inserted.

Solution :

$$C = \frac{\epsilon_0 A}{d} = \frac{(8.9 \times 10^{-12} \text{ Coul}^2 / \text{Nm}^2) (10^{-12} \text{ m}^2)}{1 \times 10^{-2} \text{ m}}$$

$$C = 8.9 \mu\text{F}$$

The free charge $q = CV = 8.9 \times 10^{-12} \times 100$

$$= 8.9 \times 10^{-10} \text{ Coul.}$$

Because of the technique used to charge the capacitor, the free charge remains unchanged as the slab is introduced. If the charging battery is disconnected, this would not be the case.

An application of Gauss' law indicates.

$\epsilon_0 \int \kappa \vec{E} \cdot d\vec{s} = \epsilon_0 \kappa EA = q$ (Since $\kappa = 1$, because the surface over which we evaluate the flux integral does not pass through the dielectric)

$$\text{So, } E = \frac{q}{\epsilon_0 A} = \frac{8.9 \times 10^{-10}}{8.9 \times 10^{-12} \times 10^{-2}} = 1 \times 10^4 \text{ Volt/m}$$

Note that E remains unchanged when the slab is introduced. But electric field strength in the dielectric medium change and is given by

$$\epsilon_0 \kappa E^1 A = q$$

Here κ appears because the surface cuts throughout the dielectric and that, only the free charge q appears on the right. Thus we have

$$E^1 = \frac{q}{\kappa \epsilon_0 A} = \frac{E}{\kappa} = \frac{1 \times 10^4}{7} = 0.14 \times 10^4 \text{ Volt/m}$$

The potential difference between the plates

$$\begin{aligned} V &= \int \vec{E} \cdot d\vec{l} = E(d-t) + E^1 t \\ &= 1 \times 10^4 (5 \times 10^{-3}) + (0.14 \times 10^4 \times 5 \times 10^{-3}) \end{aligned}$$

$$V = 57 \text{ Volt.}$$

10. would you except the dielectric constant for polar molecules to vary with temperature? Why?
11. Discuss the following statement: the permittivity is a measure of how easily a dielectric will permit the establishment of electric field lines with the dielectric

III Solve the following problems

1. When a slab of insulating material of thickness 8×10^{-3} m is introduced between the plates of a parallel plate condenser, it is found that the distance between the plates has to be increased by 7×10^{-3} m: to restore the condenser capacity to its original value. Calculate the dielectric constant of the material
(Ans : $K = 8$)
2. The distance between the plates of parallel plate condenser, is 2.4×10^{-2} m. A rectangular slab of thickness 1.2×10^{-2} m and dielectric constant 5 is placed between them and the distance
(Ans : 3.36×10^{-2} m)
3. Two rain drops, a long way apart, have radius of 2 and 2mm respectively. Their potentials are 40 to 60 esu. Respectively. What will be the change in energy if they coalesce? What will be their potential?
(Ans : 408 ergs, 856 esu)
4. A $100 \mu\text{F}$ capacitor is charged to 100 V. After charging, the battery is disconnected. The capacitor is connected in parallel to another capacitor. The final voltage is 30 V. What is the capacitance of all second capacitor.
(Ans: $267 \mu\text{F}$)
5. For a given parallel condenser $A = 0.01 \text{ sq. m.}$, $d = 0.05 \text{ m}$, $p.q = 100 \text{ V}$, when air is used. If air is replaced by glass of $K = 6$, calculate the new capacity and new p.d.
(Ans $640 \mu\text{F}$; 16.67 V)
6. Find the mechanical stress per sq cm on the glass plate of a condenser charged to a potential of 30,000 V. K and t of glass are 4 and 4×10^{-3} m. respectively. Find the electrostatic force per unit area of an insulated sphere of 5×10^{-2} m radius, charged to 177×10^{-10} Coul.
(Ans : 99.51 N/m^2 ; 44.78 N/m^2)

5.13 RECOMMENDED BOOKS

1. Halliday, D And Resnick, R	Physics – part II	Wiley Eastern Pvt Ltd. New Delhi
2. Vaudeva, D.N.	Fundamentals of Electricity and Magnetism	S.Chand and Company New Delhi.
3. Duckwork, E.	Electricity and Magnetism	Holt Reinhart and Winston Publications, New York.

Example - 4:

Derive the expression for change in energy of parallel plate condenser when a dielectric constant K and thickness t is introduced between the plates:

- (a) When the charge remains the same:
 (b) When the potential remains the same.

Solution:

Charge remains the same

(a) When the capacity = $\frac{A\epsilon_0}{d-t(1-1/k)}$

So energy $\frac{q^2}{2C} = \frac{q^2}{2A\epsilon_0} \left(d - t \left(1 - \frac{1}{k} \right) \right)$

Thus the energy is reduced on the insertion of the slab by an amount equal to

$$\frac{q^2}{2A\epsilon_0} t (1 - 1/k)$$

(a) If $d = t$ i.e. when the slab thickness is equal to the air gap of the parallel plate condenser the decrease in energy is $\frac{q^2 t}{2\kappa A\epsilon_0}$

(b) When the potential remains the same i.e., when the battery is kept connected to the plates.

The new capacity = $\frac{A\epsilon_0 \kappa}{d - t(1-1/k)}$

and hence the energy = $\frac{1}{2} CV^2 = \frac{1}{2} \frac{A\epsilon_0 \kappa V^2}{[d - t(1-1/k)]}$

Hence the energy is greater on introducing the slab than without the slab.

Thus the above two cases indicate that (a) the expression is to be used when the charge remains the same and (b) $\frac{1}{2} CV^2$ is to be used when the potential remain the same.

5.11 SUMMARY

The capacity of a parallel plate condenser is directly proportional to the area of Cross section A and is inversely proportional to the distance d between the plates.

$$C = \frac{A}{4\pi d}$$

Positive and negative charges will be separated by the introduction of a dielectric material in the electric field. This separation of charges is called polarization. Molecules can be divided into two categories; polar and non-polar molecular. Polar molecules have permanent dipole moment where as non polar molecules do not have permanent dipole moment. The dielectric constant is defined as the ratio of the capacitance with the dielectric to that without the dielectric. The dielectric constant depends upon pressure, temperature crystalline state and the frequency of the applied electric field. Dielectric constant varies with *temperature*.

**BLOCK – 2: CURRENT DENSITY, STEADY
CURRENTS AND CIRCUITS**

UNIT 6: ELECTRICAL CONDUCTIVITY

Contents

- 6.1 Objectives
- 6.2 Introduction
- 6.3 Drift velocity
- 6.4 Resistance
- 6.5 Resistivity
- 6.6 Ohms Law
- 6.7 Temperature coefficient of Resistance
- 6.8 Resistivity from atomic view point and mean free path
- 6.9 Summary
- 6.10 Model Answers
- 6.11 Sample examination questions

6.1 OBJECTIVES

This unit introduces the concept of current density and resistance, resistivity and conductivity to make you understand the concept, the unit examines.

1. The motion of electrons in a conductor.
2. The flow of current in a conductor.
3. The relation between the conductivity of a conductor and the mobility of the charge carriers; (2) the variation of resistivity with temperature.

After going through the unit you will be able to

1. Explain what the current and the current density in a conductor are;
2. Distinguish between the velocity of the variation of the electrical field and the drift velocity.
3. Understand why the resistivity of a conductor does not depend on the size or shape of the conductor; and
4. Identify non-ohmic type of conductors.

$$dq = NA e V_d dt \quad \dots(6.1)$$

The rate at which the charge is transported across a section of the wire is dq and it is called the current in the wire. Current is represented by i .

$$i = \frac{dq}{dt} \quad \dots(6.2)$$

From Eqns (6.1) and (6.2) the i is given by

$$i = NA e V_d \quad \dots(6.3)$$

The MKS unit of current is one "Coulomb per second" and is called one "ampere". Generally small currents are expressed in milli amperes ($ma = 10^{-3}$ amperes) or in micro amperes ($\mu a = 10^{-6}$ amperes)

In general, if any number of different kinds of charged particles are present (as in the case of neon tube) in different concentrations and moving with different velocities; the net charge crossing a surface in time dt is

$$dq = Adt (N_{1q1} V_1 N_{2q2} V_2 + N_{3q3} V_3 + \dots) \quad \dots(6.4)$$

and the current is

$$i = \frac{dq}{dt} = A \sum N_q V_d \quad \dots(6.5)$$

The free electrons in a metallic wire carrying current are distributed uniformly throughout the wire and the current in the wire of constant cross section is distributed uniformly across any section.

The "current density" in the wire, usually represented by J is a vector quantity and it depends on the ratio of the current to the cross sectional area A .

$$J = i A = N_e V_d \quad \dots(6.6)$$

The above equation defines the average current density over an area A . But if the current is not uniformly distributed, one has to consider an infinitesimal area dA across which the current is ' di ' and has to define the current density as

$$J = \frac{di}{dA} \quad \dots(6.7)$$

Current i is a characteristic of a particular conductor. Like mass of an object, length of an object, density of an object current is also a macroscopic quantity. The corresponding related microscopic property is the current density j . In a conductor j is characteristic of a point rather than the conductor as a whole. The relationship between J and i is that, for a



Fig 6.2 an impressed electric field causes the electrons to drift with a velocity V_d towards the right. What is the direction of E ?

The drift velocity V_d can be computed from the current density J . fig 6.3 Shows the conduction electrons in a

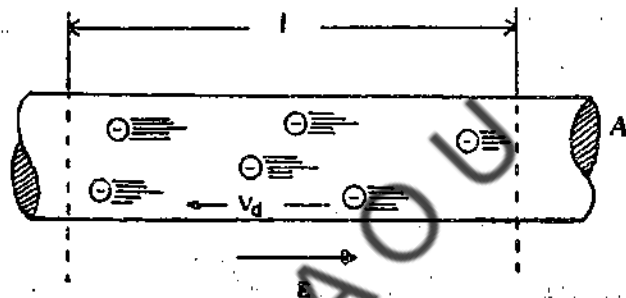

Fig 6.3 Electrons drifting in a direction opposite to the electric field in a conductor

Metallic wire moving the left side of the wire with constant drift velocity V_d and where as the field E is acting toward right. If N is the number of conduction electrons per unit volume the number of electrons in a volume ' $A l$ ' is $N A l$. A change of magnitude

$$q = (N A l) E \quad \dots(6.9)$$

passes through the wire, through its right end in a time ' t ' and is given by,

$$t = \frac{l}{V_d} \quad \dots(6.10)$$

The current i is given by

$$i = \frac{q}{t} = \frac{N A l e}{l V_d} = N A e V_d \quad \dots(6.11)$$

Solving for V and by putting $J = i / A$, Eqn. (6.6) yields

$$(8.4 \times 10^{22} \text{ electrons/cm}^3)(1.6 \times 10^{-19} \text{ Coulomb/electron})$$

$$V_d = 0.008 \text{ cm/s}$$

It means, the electrons in this copper wire will take 125 sec to drift 1 cm. So the drift speed of electrons should not be confused with the speed at which changes in electric field configuration travel along wires, a speed which approaches the speed of light.

6.4 RESISTANCE

Even in conductors, charges are not perfectly free to move. As shown in Fig 6.2 the charges follow a zigzag path. This path is the result of collisions of charges with the stationary portions of atoms constituting the conductor. During these collisions, as we have discussed earlier, the moving charges lose much of their energy flow acquired as a result of the electric field in the conductor. This lost energy always appears as heat in the conductor. In short, this conversion of electrical energy to heat can be viewed as being due to the frictional force of the moving charges.

If the potential difference of same magnitude V is applied between the ends of a copper rod and of iron rod different currents result. The characteristic of the conductor that enters here is its resistance. We can define the resistance as the ratio of the potential difference v applied between the ends of the conductor to that of the current I flowing through it. It is represented by the sign.

$$R = V/I$$

To understand the concept of resistance it is customary to compare the flow of charge through a conductor with the flow of water through a pipe, which occurs due to the difference in pressure between the ends of the pipe, established by a pump. This pressure difference can be compared with the potential difference established by a battery between the ends of a resistor. The flow of water (let us say cm^3/sec) is compared with the current (coul/s or Amp). The rate of flow of water for a given pressure difference is determined by the nature of the pipe. Is it narrow or wide? Is it short or long? Is it empty or filled with sand or gravel? Etc. These characteristics are analogous to the resistance of a conductor.

6.5 RESISTIVITY (SPECIFIC RESISTANCE) AND ELECTRICAL CONDUCTIVITY

We have seen earlier when current is passing through a conductor it offers resistance to the flow of current. It is analogous to viscous type friction force acting on the moving charges even though the actual force is not such simple. Since the viscous retarding forces are proportional to the speed of the object, one would expect, approximately, the drift velocity V_d of the charge 'q' to be proportional to the electric force tending to make it move, namely Eq . Then we shall write

$$V_d \propto Eq \quad \dots(6.13)$$

Example 1:

A cylindrical carbon rod has a diameter 2 cm and a length of 50cm. What is the resistance measured between the two ends? The resistivity of carbon is 3.5×10^{-5} Ohms² at 20°C.

Solution:
$$R = \frac{(3.5 \times 10^{-5} \text{ Ohm-m})(0.50\text{m})}{\pi (0.01\text{m})^2}$$
$$= 0.055 \text{ Ohm.}$$

Eqn. (6.7) can be used to define the resistance of any circuit element. If a voltage difference 'V' exists between its two ends, and if a current 'i' flows through it, the resistance of the element is defined to be

$$R = V/i$$

The units of resistance are volts/Coulomb per second or volts per ampere. This unit is called ohm (Ω). The units for resistivity are Ohmmeter. The units for conductivity are Ohms (Ω)/meter

6.6 OHM'S LAW

Eqn. (6.7), $V = iR$ is always true provided a steady current is maintained through a resistance element by a fixed voltage V. The ratio V/i is defined to be the resistance of the element. This equation was first found experimentally by George Simon Ohm (1789-1845). He implied that R is independent of V and i over reasonable ranges of V and i. The relation $R = V/i$ is known as Ohm's law. In general R is not a constant. We have to discard Ohm's idea that R does not vary. Moreover heating of material changes its resistance.

As a result Ohm's law fails. Eqn.(6.7), one major portion of Ohm's law, is always true if V and I can be reproduce. As long as the temperature is kept constant almost all the metallic conductors obey ohm's law. (Fig 6.2) Many conductors don't obey Ohm's law. For

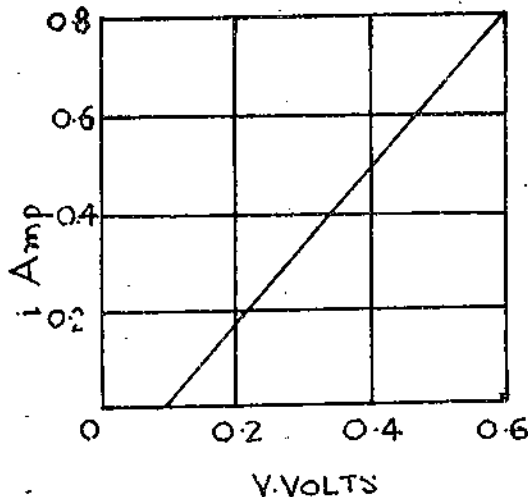

Fig. 6.5. The current variation as a function of potential difference in a copper wire. This obeys Ohm's law

$$\rho = \rho_{\text{ref}} [1 + \alpha (t - t_{\text{ref}})] \quad \dots (6.20)$$

$$\text{or } \rho = \rho_{\text{ref}} [1 + \alpha (t - \Delta t)]$$

$$\therefore \frac{1}{\rho} \frac{\Delta \rho}{\Delta t} = \frac{1}{\rho_{\text{ref}}} \cdot \frac{\rho - \rho_{\text{ref}}}{t - t_{\text{ref}}} \quad \dots (6.21)$$

In this relation ρ is the resistivity at temperature t , and ρ_{ref} is the resistivity at some reference temperature, t_{ref} . α is an experimental constant called the temperature coefficient of resistivity and is given by the relation (6.8a)

The resistivity of copper is 1.7×10^{-8} Ohm-m and that of quartz is 10^{16} Ohm-m. Few physical properties are measurable over such a range of values; Table 10.1, lists some values of ρ and α for common substances.

Table 6.1 Resistivities and their Temperature coefficients.

Material	Resistivity (P) at 200C	α at 20°C (per°C)
Silver	1.6×10^{-3}	3.8×10^{-3}
Copper	1.7	3.9
Aluminium	2.8	3.9
Tungsten	5.6	4.5
Nickel	6.8	6.0
Iron	10.0	5.0
Manganin	44.0	1000.0
Graphite (carbon)	3500.0	-0.5
Glass	10^{11}	-
Amber	5×10^{14}	-
Quartz (Fused)	75×10^{16}	-

Check Your Progress

1. The current density in a wire represented by J given in terms of.....
2. Drift velocity of an electron is given by
3. Equation for temperature co-efficient of resistance is given by
4. Conductors which do not obey Ohm's law are called

Note:

- a. Space is given below for your answers.
- b. Compare your answers with those given at the end of the unit.

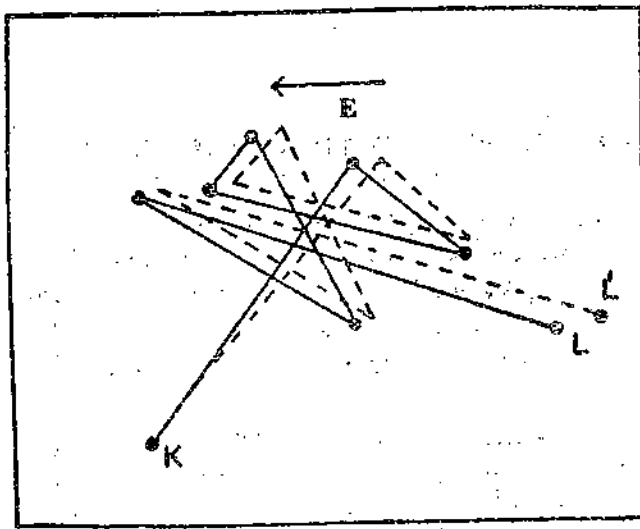

Fig 6.8 the solid lines indicate an electron moving from K to L making six collisions. The dashed line show what could be the electron path in the presence of an external field E. Note the steady drift in a direction opposite to E.

The drift velocity can be obtained in term of the applied electric field E and v and λ . When a field is applied to the electron in the metal it will experience a force eE which will impart to it an acceleration a given by 2nd law of Newton.

$$a = \frac{\vec{F}}{m} = \frac{e\vec{E}}{m} \quad \dots(6.22)$$

Let us consider that an electron has collided with one positive ion core.

Naturally at its next collision the electron's velocity will have changed the average by a $(1/v)$, where $(1/v)$ is mean time t taken between collisions. The drift speed V_d , is

$$V_d = a \left[\frac{\lambda}{v} \right] = \frac{Ee}{m} \cdot \frac{\lambda}{v}, \quad T = \frac{\lambda}{v} \quad \dots(6.23)$$

We may write V_i in terms of the current density J [Eqn. (6.22)] and combining Eqn. (6.10) to get.

$$\vec{V}_d = \frac{\vec{J}}{Ne} = \frac{Ee}{m} \frac{\lambda}{v}$$

Combining this with Eqn. (6.16) ($E/J = \rho$) leads finally to

$$\rho = \frac{mv}{Ne^2\lambda} \quad \dots(6.24)$$

This equation can be taken as a statement that metals obey Ohm's law if we can show that v and λ do not depend on E. In this case ρ will not depend on the applied electric field E, which is the criterion for a material to obey Ohm's law. The quantities λ and v depend mainly on the velocity distribution of conduction electrons. v is of the order of 10^{10} cm/sec and V_d is of the order 10^{-2} to 10^{-3} cm/sec. The ratio is approximate 10^{10} . Hence for all practical purposes the right hand side of Eqn. (6.2) is independent of E and the material obeys Ohm's Law.

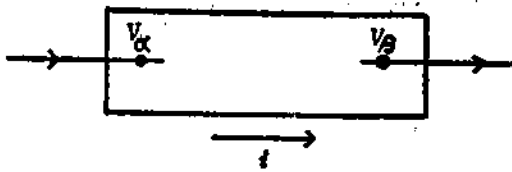

Fig 6.9 Transfer of charge in a portion of the circuit

In a time interval 'dt' a quantity of charge $dp = idt$ enters the portion of the circuit under consideration at terminal α and in the same time an equal quantity of charge leaves the terminal β . Thus there is transfer of charge up from a potential V_α to a potential V_β . The energy W given up by the charge is

$$dW = dq (V_\alpha - V_\beta) = idtV_{\alpha\beta} \quad \dots(6.25)$$

The rate at which energy is given up is given up, or power input

$$P = \frac{dW}{dt} = iV_{\alpha\beta} \quad \dots(6.26)$$

So the power input only depends on the magnitude and relative directions of currents and terminal potential difference. The power input is equal to the product of the current and the potential difference. If i is in amps or Coul/s, and the potential difference is in volts or Joules/Coul, the power is in Joules/s or Watts, since

$$\frac{\text{Coul}}{\text{s}} \times \frac{\text{Joules}}{\text{Coul}} = \text{Joules/s} = \text{Watts}$$

Eqn.(6.25) is a general relation and holds good for many circuit element between α and β .

In a special case in which, the circuit element between α and β is a pure resistance, R all of the energy supplied is converted into heat and in this case the potential difference, $V_{\alpha\beta}$ is given by

$$V_{\alpha\beta} = iR \quad \dots(6.27)$$

Hence $P = iV_{\alpha\beta} = i \times iR = i^2R$

$$P = i^2R \quad \dots(6.28)$$

$$\text{or } P = \frac{V_{\alpha\beta}^2}{R} \quad (\text{Since } V_{\alpha\beta} = iR) \quad \dots(6.29)$$

Here in this case we may set

Example 2:

A current of 0.25 Amp flow!; through a 200 Ω resistor. How much power is lost in the resistor?

Solution:

Applying Eqn. i.e, $P = iV = i^2R$

$$P = (0.25)^2 \times 200 = 12.5 \text{ Watts.}$$

So, in this case 12.5 J of energy is lost each second and hence 12.514 .185 or about 3 cal of heat is generated each second.

Example 3:

A bulb rated 220V/100 W is operated from a 220 V power source. Find the current flowing through it and its resistance.

Solution:

$$P = Vi$$

$$i = \frac{p}{V} = \frac{100W}{220V} = 0.45 \text{ Amps}$$

Since the potential drop across the bulb is 220V and the current is 0.45 amps, Ohm's law tells us

$$R = \frac{V}{i} = \frac{220}{0.45} = 484 \Omega$$

6.9 SUMMARY

In a good conductor there are number of free charges. These charges move under the influence in an external electric field. Current per unit area is called the charge density. Charge density is proportional to the magnitude of the charge (q), number of charges carries (N), and the average drift velocity.

Conductivity of a conductor depends on the mobility of the charge carriers & the resistivity and conductivity are the intrinsic properties of the material and depends on the temperature but not on the size or shape of the conductor. At a given temperature the Potential difference between the ends of conductor is directly proportional to the current flowing through it. It is known as Ohm's Law. Vacuum tubes gas tubes, semiconductors and thermistors and thyristors do not obey Ohm's Law. These are called no-Ohmic type of conductors.

Electrons are the carriers of current. Moving charges constitute the current. While moving electrons collide with positive ion cores. Which results in the transfer of their

II. Answer the following questions briefly

1. Derive the expression for electrical power in a conductor.
2. Basing on the conductivity scale can you classify the elements? If so what are they? Give some examples in each case.
3. Can you imagine a phenomenon at very low temperature (near 0° , K) the resistance of a metallic conductor becomes almost zero? What is that phenomenon? Write a brief note on this phenomenon.
4. What is semiconductor? Explain why the resistance decreases with increasing temperature in the case of a semiconductor.
5. What is magneto resistance? Give some examples.
6. Distinguish clearly between the electron flow and the conventional current.
7. What is wrong with the following statement: 'the resistivity of a material is directly proportional to its length'? Rectify the statement and explain.
8. Distinguish between current and current density.
9. What is the difference between electromotive force and potential difference? Are they same? What are the units?
10. Explain the concept of resistance of flow of current in a conductor.

III. Solve the following problems.

1. A silver wire has a radius of 1.0 mm and it carries 2 amps current. Find the current density in the wire
(Ans: $6.4 \times 10^6 \text{ A/m}^2$)
2. What voltage difference is required to send a current of 2 amps through 50 cms of wire in the above example?
(Hint: Use the expression $R = \rho l/A$)
(Ans: $5.4 \times 10^{-3} \text{ V}$)
3. Calculate the drift speed in the problem-1
(Ans: $v_d = 7 \times 10^{-5} \text{ m/sec}$)
4. A current of 5 amps exists in a 10 Ohm resistor for 4 min. (i) How many Coulombs and (ii) how many electrons pass through any cross-section of the resistor in this case?
(Ans: 1200 Coul; 7.5×10^{21} electrons)
5. A square aluminium rod is edge 1.0 meter long and 5.0 mm on edge
(a) What is its resistance between the ends?

$$\text{[Hint: Use in } = \frac{\text{Avagadro Number} \times \text{density}}{\text{Atomic Weight}} = \frac{6.0 \times 10^{23} \times 8.9}{59} \text{]}$$

6.12 GLOSSARY

1. Incandescent light produced by glowing filament.
2. Statical machine A machine that produces high potential using static electricity principle.
3. Thermoelectricity Thermoelectric effects involve conversion of heat energy into electrical energy, Example: Thermocouple
4. Thermistor thermally sensitive resistor, in which the resistance decreases with increasing temperature.

maintaining the continuous flow of water through a system of pipes as shown in Fig. 7.1 (b). The source of emf must do certain amount of work on each unit of charge, which passes through it in order to raise it to a higher potential. The work must be supplied at the rate at which energy is lost in flowing through the circuit.

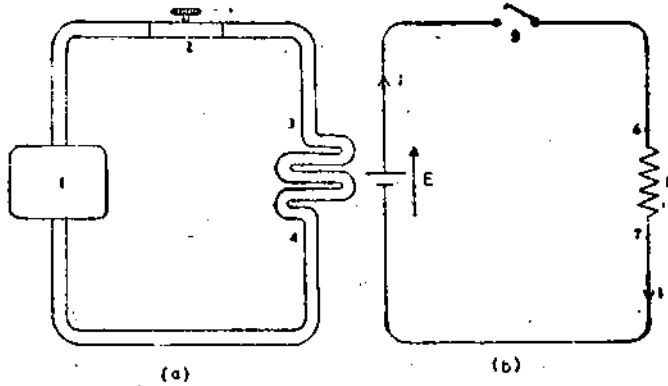

Fig 7.1 (a) Mechanical analogy of a water pump
7.1 (b) Sources of emf in an electrical circuit.

1. Water pump 2. Valve 3. High-pressure 4. Low pressure 5. Switch 6. High potential 7. Low potential.

By convention, we assume that the current consists of a flow of positive charge even though in most cases it is negative electrons. Hence the charge loses energy in passing through the resistor from a higher potential to a lower potential. In the analogy of water pump, the water flows from high pressure to low pressure. When the shut off valve is closed, pressure exists but no water flows, Similarly when the electrical switch is open there is voltage but no current. Since the emf is the work done on the unit charge. It is expressed in the same unit as potential difference i.e., Joule per second or volt. If dq is the charge crossing a section through the source of emf in time dt and dw is energy transformed in this time then the emf is

$$E = dw/dq. \quad \dots(7.1)$$

Therefore the work done by the source in time dt is

$$dW = E dq. \quad \dots(7.2)$$

And the rate of work done or the power is

$$P = \frac{dW}{dt} = E \frac{dq}{dt} = Ei. \quad \dots(7.3)$$

“ A source of emf of one volt will perform one Joules of work on each Coulomb of charge which passes through it”

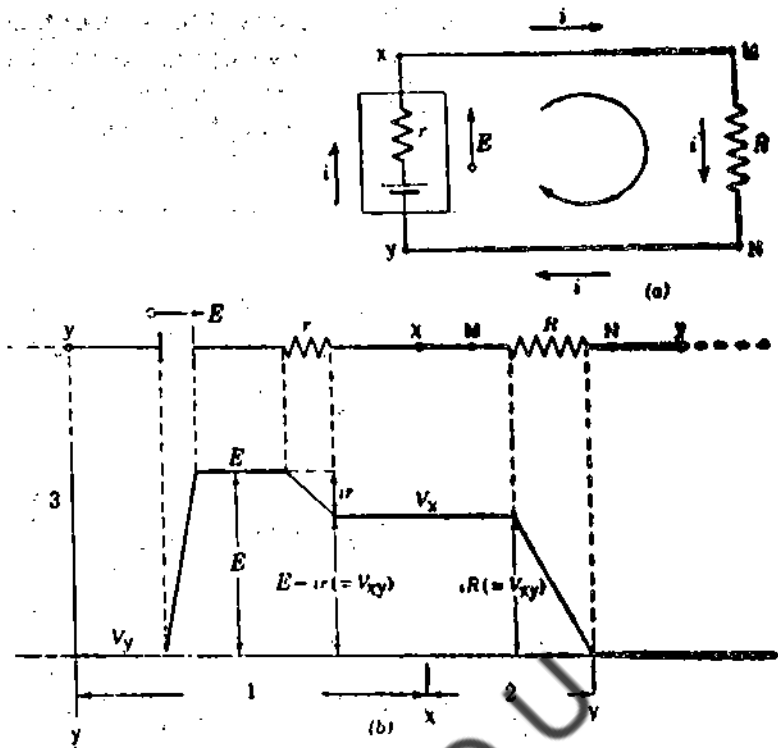

Fig 7.2 (a) A single loop circuit. The rectangular block is a seat of emf E with an internal resistance r .

(a) The same circuit is drawn for convenience as straight line. Directly below are shown the potential changes that one comes across in traversing the circuit clockwise.
 (1) Seat of emf (2) External resistor (3) Potential, Volts

Example 1:

When four resistance are connected between x and y in series so that there is only one conducting path through all these resistance as shown in fig 7.3 what is the effective resistance R of all these resistances?

Solution:

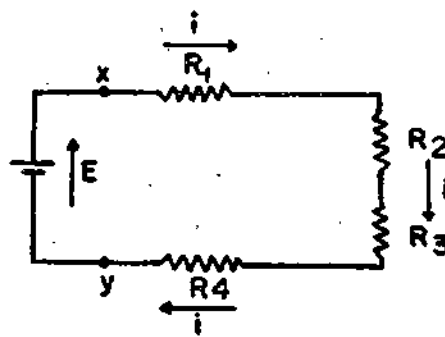

Fig 7.3 Four resistances are connected in series between the terminals x and y

Solving for Yields

$$i = \frac{E_2 - E_1}{R + r_1 + r_2}$$

$$i = \frac{(8 - 4) \text{ volts}}{(10 + 2 + 4) \text{ Ohms}} = 4/16 = 0.25 \text{ Amp}$$

(a) The potential difference between x and y can be obtained by starting at y and traversing the circuit to x

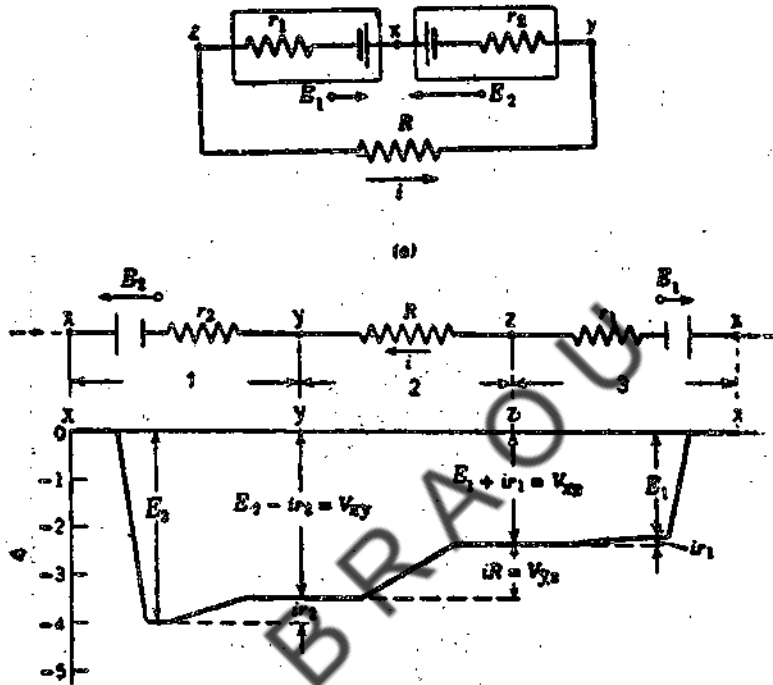

Fig 7.4 a) Single loop unit

a) The same circuit for convenience is schematically shown as a straight line. The potential differences encountered in traversing the circuit clockwise direction from Point x being represented directly below. In the lower figure the potential at point z was assumed to be zero.

1. Seat of emf 2, 2. External resistor, 3. Seat of emf 1,
 4. Potential volts. $E_1 = 4V$, $E_2 = 8V$, $r_1 = 2\Omega$, $r_2 = 4\Omega$
- $$V_{xy} = (V_x - V_y) = ir_2 - E_2 + E_2 = E_2 - ir_2$$
- $$= 8 \text{ volts} - (0.25 \text{ Amp}) (4 \text{ ohm})$$
- $$= 7.0 \text{ Volt.}$$

The x point is more positive than y and the potential difference (7.0 volts) is less than the emf (8.0 volts). See Fig 7.4 (b)

(b) For points z and x we start at z and traverse the circuit to x

Applying the loop theorem to various loops. We can solve this, If we traverse the left loop of Fig 7.5 in a counter clock wise direction, the loop theorem gives

$$E_1 + i_3 R_3 - i_1 R_1 = 0 \quad \dots(7.10)$$

The right loop gives

$$-E_2 - i_2 R_2 - i_3 R_3 = 0 \quad \dots(7.11)$$

using the three equations and solving for i_1 , i_2 and i_3 we get

$$i_1 = \frac{(R_1 + R_2) E_1 - E_2 E_3}{R_1 R_2 + R_2 R_3 + R_3 R_1} \quad \dots(7.12)$$

$$i_2 = \frac{E_1 R_3 - E_2 (R_1 + R_3)}{R_1 R_2 + R_2 R_3 + R_3 R_1} \quad \dots(7.13)$$

$$i_3 = \frac{-E_1 R_2 - E_2 E_1}{R_1 R_2 + R_2 R_3 + R_3 R_1} \quad \dots(7.14)$$

Suppose if R_3 is infinite then

$$i_1 = i_2 = \frac{E_1 - E_2}{R_1 + R_2} \quad \text{and} \quad i_3 = 0$$

When the loop theorem is applied to the entire loop ACBDA of Fig 7.5 the loop theorem yields.

$$i_1 R_1 - i_2 R_2 - E_2 + E_1 = 0 \quad \dots(7.15)$$

Which is nothing more than the sum of Eqns. (7.10) and (7.11)

Check your progress:

1. The two laws of Kirchoff's (a) Law of currents (b) Law of emf's are stated as.....
2. Kirchoff's laws are applied in

Note: a. Space is given below for your answers.

b. Compare your answers with those given at the end of the unit.....

.....

.....

.....

.....

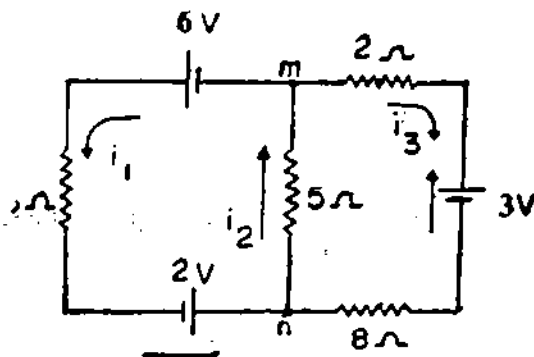

Fig 7.7

$$\Sigma i(\text{entering}) = \Sigma i(\text{leaving})$$

$$i_2 = i_1 + i_3$$

Starting from 'm' and tracing counter-clockwise around the left loop, we write law voltage equation.

$$E = iR$$

$$6V + 2V = i_1 (3\Omega) + i_2 (5\Omega) \quad \dots(I)$$

$$8V = (3\Omega)i_1 + (5\Omega) i_2$$

Dividing throughout by 1 Ω and transposing we get

$$3i_1 + 5i_2 = 8 \text{ Amps. (1V/\Omega = 1A)} \quad \dots(II)$$

Another voltage equation can be written by starting from 'm' and tracing clockwise around the right loop

$$-3V = i_3 (\Omega) + i_2 (5\Omega) + i_3 (8\Omega)$$

The negative sign arises from the fact that the output of the source opposes the racing direction. Simplifying we have

$$2i_3 + 8i_3 + 5i_2 = -3A$$

$$10i_3 + 5i_2 = -3A \quad \dots(III)$$

The three simultaneous equations which must be solved for i_1 , i_2 , and i_3 are

$$i_1 + i_2 + i_3 = 0 \quad \dots(I)$$

$$3i_1 + 5i_2 = 8A \quad \dots(II)$$

$$10i_3 + 5i_2 = -3A \quad \dots(III)$$

From the Eqn. (I) we have

$$i_1 = i_2 - i_3$$

Check your progress: Answers

- (a) First law states that the sum of currents entering a junction is equal to the sum of currents leaving that junction or at any junction the algebraic currents must be zero.
$$\Sigma i \text{ entering} = \Sigma i \text{ leaving}$$

(b) Second law states that the sum of emf's around any loop of current is equal to the sum of all the voltage drop across the impedances in that closed circuit.
- Kirchoff's laws are applied in multi loop circuits.

7.8 SAMPLE EXAMINATION QUESTIONS

I Answer the following quotations in detail

- Define Kirchoff's laws. Apply them to a single loop circuit and derive the expressions for current and potential difference.
- Apply the Kirchoff's laws to a multiple loop circuit and obtain the expressions for the potential difference and current.

II Answer the following questions briefly.

- What is electromotive force? What is internal resistance of a source of emf.
- Discuss the meaning of Kirchoff's laws in terms of the conversion laws.
- Why would one connect two batteries in series? In Parallel? Why should unlike batteries never be connected in parallel?
- Distinguish between terminal potential difference and emf.
- In an electric circuit, it is desired to decrease the effective resistance by adding resistors. Should these resistors be connected in parallel or series? Why?
- Defend the following statement; the effective resistance of a group of resistors connected in parallel will be less than any of the individual resistances.

P.D. across $Y_1 = E_1 - E_a$

$$Y_2 = E_a - E_b$$

$$Y_3 = E_b - E_c - E_2$$

$$Y_4 = E_a$$

$$Y_5 = E_b - E_c$$

$$Y_6 = E_c$$

Let i_1, i_2, i_3, i_4, i_5 and i_6 be the currents in different admittances respectively, applying kirchoffs 1st law for Junction 'a'

$$i_1 - i_2 - i_4 = 0$$

$$y_1 (E_1 - E_a) - Y_2 (E_c - E_b) - Y_4 E_a = 0$$

$$E_a (-y_1 - y_2 - y_4) + E_c y_2 = -y_1 E_1 \quad \dots(8.1)$$

For kirchoffs 1st law for jn 'b'

$$i_1 - i_3 - i_5 = 0$$

$$Y_2 (E_a - E_b) - Y_3 (E_b - E_c - E_2) - Y_5 (E_b - E_c) = 0$$

$$E_a (Y_2) + E_b (-Y_2 - Y_3 - Y_5) + E_c (Y_3 + Y_5) = -Y_3 E_2 \quad \dots(8.2)$$

From kirchoffs 1st law for jn 'c'

$$i_3 + i_5 - i_6 = 0$$

$$Y_3 (E_b - E_c - E_2) + Y_5 (E_b - E_c) - Y_6 (E_c) = 0$$

$$E_b (Y_3 + Y_5) + E_c (-y_3 - y_5 - y_6) = Y_3 E_2 \quad \dots(8.3)$$

From the above three equations E_a, E_b and E_c can be calculated

8.4 SUPERPOSITION THEOREM

In a circuit containing resistances and Networks, the current flowing through a point is equal to, the sum total of the individual currents flowing in each network. But while deciding flow of current through a network we have to imagine their internal resistance in place of other networks.

Further more, this theorem shows that in a circuit. If there are voltage networks and current networks working at a time, each network will work independently. That is why we can calculate the effect due to individual network.

5. Use Kirchoff's law to solve the currents through the circuit illustrated in 3.

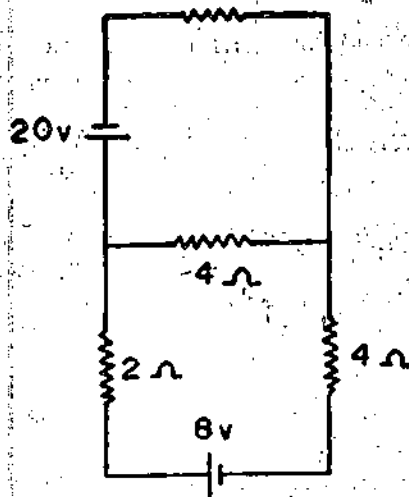

Fig 3

[Ans: $i_1 = 23.8\text{ma}$, $i_2 = 190\text{ma}$, $i_3 = 214\text{ma}$]

6. Apply the Kirchoff's laws to the following circuit and obtain the currents through each branch.

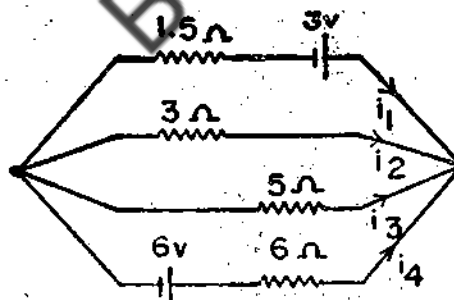

Fig 4

[Ans: $i_1 = 546\text{ma}$, $i_2 = 732\text{ ma}$, $i_3 = 439\text{ ma}$, $i_4 = 634\text{ ma}$,]

UNIT – 8 NETWORKS

Contents

- 8.1 Objectives
- 8.2 Introduction
- 8.3 Mesh and Node Analysis
- 8.4 Superposition theorem
 - 8.4.1 Proof of Theorem
 - 8.4.2 Procedure for application
- 8.5 Reciprocity Theorem
- 8.6 Thevenin's Theorem
 - 8.6.1 Procedure for application of theorem
 - 8.6.2 Proof of theorem
- 8.7 Norton's Theorem
 - 8.7.1 Procedure for application theorem
 - 8.7.2 Application of Norton's theorem
- 8.8 Duality of Thevenin's & Norton's Equivalent Circuits
- 8.9 Summary
- 8.10 Worked out Examples
- 8.11 Sample Examination Questions

8.1 OBJECTIVES

This unit introduces the concept of Networks. To help you understand them, the unit explains:

- (i) Mesh and node analysis
 - (ii) Super position theorem
 - (iii) Thevenins & Norton's theorem.
- (i) Understand the circuit analysis
 - (ii) Explain the application of network theorems:

When E_2 is considered alone, mesh of Fig 8.2 gives.

$$0 = I_1^{II}(Z_1 + Z_3) + I_2^{II} Z_3 \quad \dots(8.8)$$

$$\text{And } E_2 = I_2^{II}(Z_2 + Z_3) + I_1^{II} Z_3 \quad \dots(8.9)$$

Adding Equations 8.6 & 8.8 we get

$$E_1 = (I_1^{I} + I_2^{I})(Z_2 + Z_3) + (I_2^{I} + I_2^{II})Z_3 \quad \dots(8.10)$$

Adding Equations 8.7 & 8.9 gives

$$E_2 = (I_2^{I} + I_2^{II})(Z_2 + Z_3) + (I_1^{I} + I_1^{II})Z_3 \quad \dots(8.11)$$

Equations 8.10 and 8.11 are identical with the equation 8.4 & 8.5 respectively, if

$$I_1 = I_1^{I} + I_1^{II}$$

$$\text{And } I_2 = I_2^{I} + I_2^{II}$$

This proves the truth of superposition theorem. The superposition theorem simplifies network calculations when several generators are present.

8.4.2 Procedure for application

The procedure to apply superposition theorem is as given below.

- (i) Only one source is considered at a time and all other sources are replaced if there is a current source, it is replaced by an open circuit because its internal resistance is infinite. We must keep only one source E_1
- (ii) Current in various resistors and then voltage drops is then calculated due to this single source.
- (iii) This procedure is repeated for other sources one by one i.e E_2 also.
- (iv) Algebraic sum of current voltage drops over a resistor due to different sources is then calculated to obtain the net current and voltage drop in any branch / resistor.

Note: In case of AC networks, according to the superposition theorem.

In any network containing more than one voltage or current source, the current through any branch is the phasor sum of the currents due to each source acting independently.

In the above-mentioned way problems can be solved.

Examples: Find the current I in the circuit given below using super position theorem.

Solution: Considering first the voltage source alone, the circuit is reduced to fig, 8.3 when current source is open circuited, then

Proof : To prove the theorem, consider the arrangement shown in fig 8.6 in which E is a emf source is in the first mesh. Let the current in first & 2nd meshes be I_1 and I_2 respectively taking 8.6 (a) alone.

Applying kirchoff II law to the two meshes, we have

$$I_1 (Z_1 + Z_2) - I_2 Z_2 = E \quad \dots (8.12)$$

$$\text{And } I_2 = (Z_2 + Z_3) - I_1 Z_2 = E \quad \dots (8.13)$$

Substituting the value I_1 from 8.12 in to 8.13 we get,

$$I_2 \left[\frac{(Z_1 + Z_2)(Z_2 + Z_3)}{Z_2} - Z_2 \right] = E$$

$$\text{Or } I_2 = \frac{EZ_2}{[(Z_1 + Z_2)(Z_2 + Z_3) - Z_2^2]} \quad \dots (8.14)$$

Considering Fig No 8.6 (b) in which the source of emf is in second mesh, let the current in the two meshes be I_1' & I_2'

Applying kirchoff's II law to the two meshes we get

$$I_1' (Z_1 + Z_2) - (I_2' Z_2 = E \quad \dots 8.14 (a)$$

$$\text{And } I_2' (Z_2 + Z_3) - I_1' Z_2 = 0 \quad \dots 8.14 (b)$$

Substituting the value of I_2' from eq 8.14 (a) into Equations, 8.14 (b) we get

$$I_1' \left[\frac{(Z_1 + Z_2)(Z_2 + Z_3)}{Z_2} - Z_2 \right] = E$$

Or

$$I_1' = E Z_2 / [(Z_1 + Z_2)(Z_2 + Z_3) - Z_2^2] \quad \dots (6)$$

From equations (8.3) & (8.6) We get

$$I_2 = I_1'$$

Which proves the reciprocity theorem.

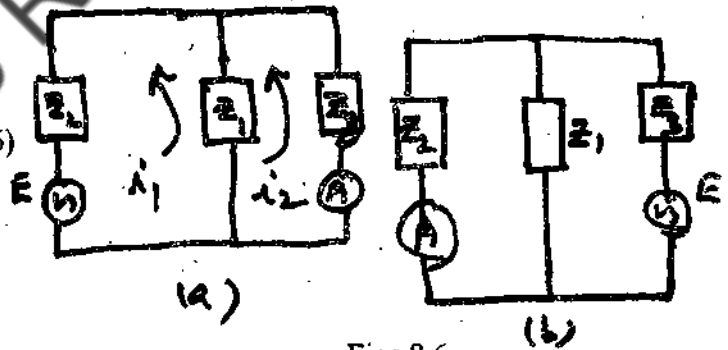

Figs 8.6
(a) & (b)

The ratio of emf in one branch to the current in another branch is called the Transfer impedance.

8.6 THEVENIN'S THEOREM

This theorem is useful in reducing a complicated network containing several voltage generators & resistances into a simple equivalent voltage i.e. generator equivalent voltage is E_o & resultant resistance R_o . It can be treated as a circuit containing these two

$$I_1 R_1 + (I_1 - I_2) R_3 = E$$

$$\text{i.e. } I_1 (R_1 + R_3) - I_2 R_3 = E$$

$$\text{and } I_2 R_2 + I_2 [R_2 (I_1 - I_2) R_3] = 0$$

$$\text{i.e. } I_2 (R_2 + R_2 + R_3) - I_1 R_3 = 0$$

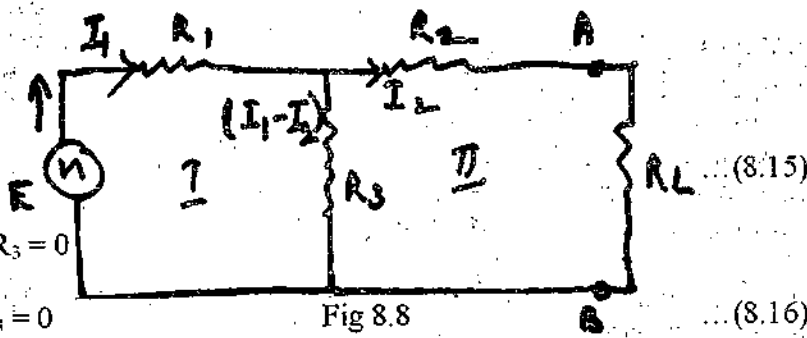

$$\text{From (2), } I_1 = I_2 \frac{(R_2 + R_3 + R_2)}{R_3}$$

Substituting this value of I_1 , in equation 8.15 we get

$$I_2 [(R_2 + R_3 + R_1) (R_1 + R_3) - R_3^2] = ER_3$$

$$\text{This gives } I_2 = \frac{ER_3}{R_2 [R_1 + R_3] + R_1 R_3 (R_1 + R_3)} \quad \dots (8.17)$$

This is the current flowing through load impedance R_2 Equation 8.17 may be put in the following form

$$I_2 = \frac{ER_3 / (R_1 + R_3)}{R_2 + \left(\frac{R_1 R_3}{R_1 + R_3} \right) + R_L}$$

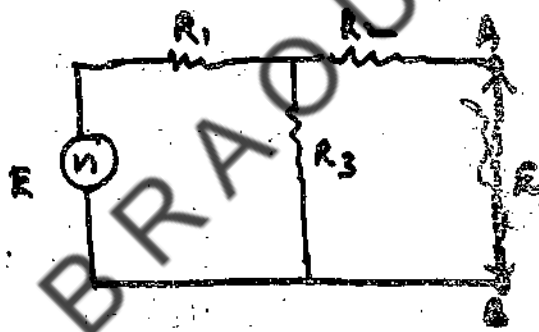

Fig 8.9 ... (8.18)

This current is same as it would flow in R_L if R_L were connected to a generator of emf

$$\frac{ER_3}{R_1 + R_3} \text{ and internal resistance } \left[R_2 + \frac{R_1 R_3}{R_1 + R_3} \right]$$

If R_L is removed (i.e terminal A and B are open circuited) the current in R_1 & R_3 will be

$$I_1 = \frac{E}{(R_1 + R_3)} \quad \dots (8.19)$$

i.e voltage across R_3 will be

$$V = I_1 R_3 = \frac{ER_3}{(R_1 + R_3)} \quad \dots (8.19(a))$$

Statement : The current in a load resistance between two terminals of a network of generators & resistances I_N is the same as if the load resistance were connected to a constant current source, whose generated current is equal to the short circuit current between the same terminals of network & which is placed in parallel with a resistance R_N equal to the resistance of the network looking back into terminals when all the generators in the network have been replaced by the resistance equal to their internal resistances.

The schematic figure of Norton's theorem is shown in fig 8.11

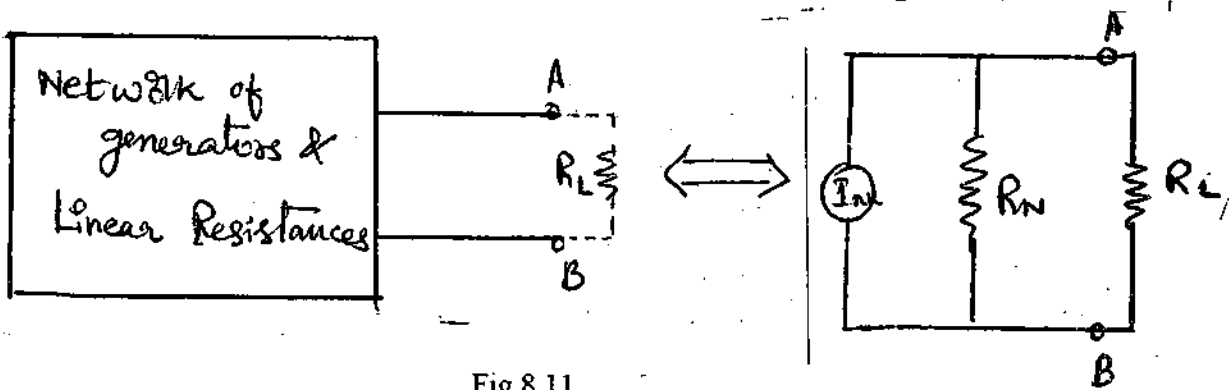

Fig 8.11

To apply the theorem, the following steps are adopted.

8.7.1 Procedure: For application of the Norton's theorem:

Suppose we want to find the current through resistance R_L connected to terminals A & B of the network of generators & linear resistances.

- (i) R_L is disconnected from terminals A and B and terminals A & B are short circuited.
- (ii) The current in the short circuit is found by usual methods. This current is usually called Norton's current I_N .
- (iii) The short circuited terminals A & B is removed so that they are again open & the generators are removed from the network leaving behind their internal resistances & equivalent resistance of the network as looked from open terminals A and B is found. This resistance is Norton's resistance R_N .
- (iv) Norton's equivalent circuit is sketched, keeping current source I_N & resistance R_N in parallel & again load resistance R_L is connected between A & B finally current in load resistance R_L is calculated.

8.7.2 Application of Norton's theorem

To practically show the application of this theorem to problems we shall consider a network as shown in Fig 8.12 (a). Norton's equivalent is shown in fig 8.12 (b).

Substituting this value of I_1 in equation 8.24 we get

$$(R_2 + R_3) \left[\frac{(R + R_3)}{R_3} \right] I_N - I_N R_3 = E$$

$$\begin{aligned} \text{Solving for } I_N, \text{ We get } I_N &= \frac{ER_3}{R_1 R_2 + R_3 + R_1 + R_3 + R_2 + R_3 - R_3^2} \\ &= \frac{ER_3}{R_1 R_2 + R_3 R_1 + R_2 R_3} \end{aligned} \quad \dots (8.26)$$

The parallel impedance R_N is found by looking back from the out put terminals. When All sources are removed leaving behind their internal resistances.

Therefore equivalent circuit is shown in fig 8.13(b) the resistance as viewed from out terminals in Norton's resistance given by

$$R_N = R_2 + \frac{R_1 R_3}{R_1 + R_3} \quad \dots (8.27)$$

Thus knowing the values of I_N and R_N the current in load may be found by using Equation 8.23 (a).

8.8 DUALITY OF THEVENIN'S & NORTON'S EQUIVALENT CIRCUITS

Consider the thevenin's & Norton's equivalent circuits of same network shown in fig. 8.14 (a) and 8.14 (b)

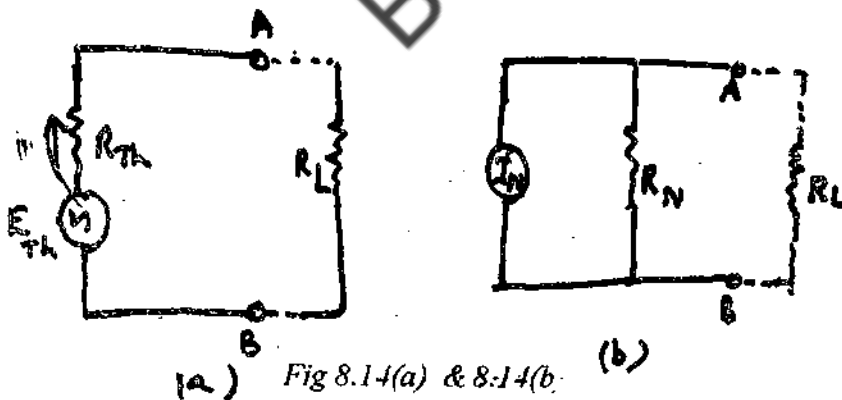

The current I_R for Thevenin's equivalent circuit in load R_L is given below.

$$I_R = \frac{E_{Th}}{R_{Th} + R_L} \quad \dots (8.28)$$

The current I_L in load for Norton's equivalent circuit in load R_L is given by

8.10 SOME TYPICAL WORKED OUT EXAMPLES.

- (1) A battery of emf 10 Volts and internal resistance 0.5Ω is joined parallel with another battery of emf 15 volts and internal resistance 1Ω . This combination sends a current through an external resistance 20 ohms. Calculate the current through each battery.

Solution : Let the current through batteries B_1 and B_2 be I_1 & I_2 respectively.

Applying kirchoffs II law, to the mesh ABFEA at point C

$$I_1 + 0.5 + (I_1 + I_2) 20 = 10$$

$$\text{Or } 20.5 I_1 + 20 I_2 = 10$$

Applying kirchoffs II law, to CDEFC

$$I_2 + 1 + (I_1 + I_2) \times 20 = 15$$

$$\text{i.e. } 21 I_2 + 20 I_1 = 15$$

Solving equations (1) & (2) we got

$$I_1 = 2.94 \text{ Amp \& } I_2 = 3.525 \text{ Amp.}$$

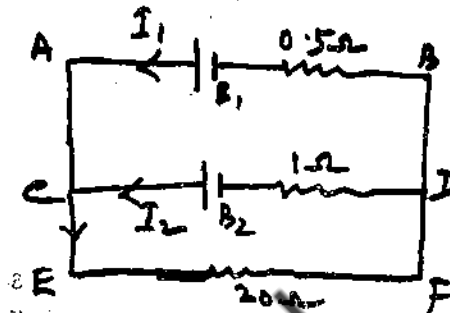
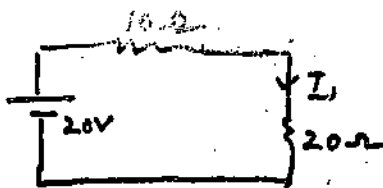

Fig I

- (2) Find the current I in the circuit given below using superposition theorem.

Solution : Considering first the voltage source alone the circuit is reduced to fig. Below when current source is open circuited Then $I_1 = 20/30 = 0.66$ Amps.

Now considering the 2 Amps. Current source alone (short circuiting the voltage source) fig. Below is obtained.



(b)

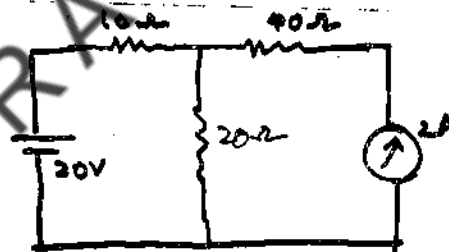

(a)

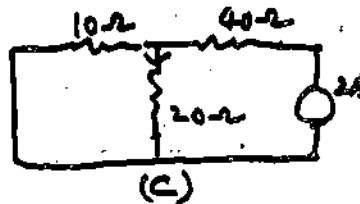

(c)

Fig II a,b,c

Fig II

The current flowing through 20Ω resistance.

$$I_2 = 2 \times \frac{10}{10+20} = \frac{20}{30} = 0.66 \text{ Amp}$$

Applying principle of superposition the total current through 20Ω resistance in

$$I = I_1 + I_2 = 0.66 + 0.66 = 1.32 \text{ Amp.}$$

- (3) Find the current in 20Ω resistors in the circuit shown III by thevenins theorem.

SOLUTION : The open circuit voltage i.e. when load R_L is disconnected, is given by

$$E' = E \frac{R_3}{R_1 + R_3} = \frac{6 \times 6}{2 + 6} = 3 \text{ Volts}$$

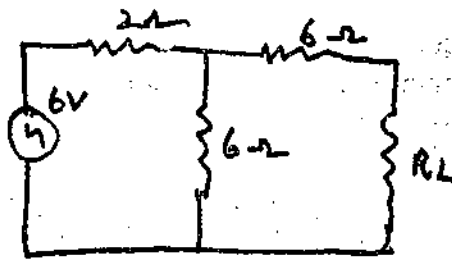

(a)

Fig V

The impedance across load terminals after disconnecting the B load R_L is

$$Z = R_2 + \frac{R_1 + R_3}{R_1 + R_3} = 6 + \frac{2 \times 6}{2 + 6} = 6 + 1.5 = 7.5 \Omega$$

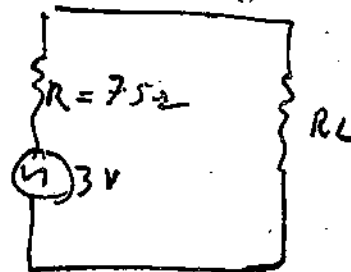

Fig VI (a)

Accordingly Thevenin's equivalent circuit is shown as the one beside is Fig VI(b)

6) Find the Thevenin's equivalent for the circuit given below Fig VII(b)

Solution: With terminals A,B open the P.D across A,B is theorem same as across 4Ω Resistance. Therefore

$$V_{AB} = \frac{12 \times 4}{2 + 4} = 8 \text{ Volt}$$

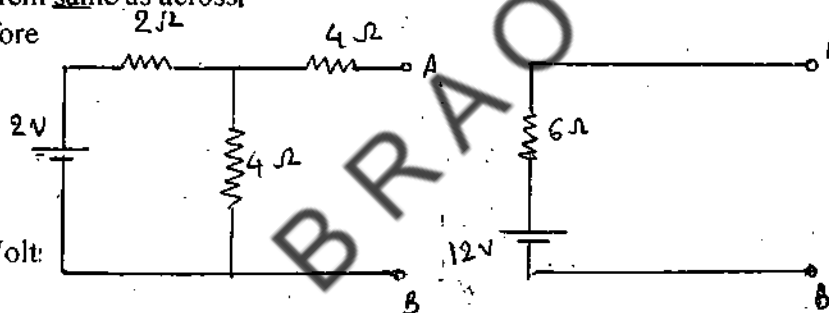

In order to find the impedance between A,B We short circuit the 12 V battery, so that 2Ω & 4Ω resistance become parallel, and their effective resistance is

$$R = \frac{2 \times 4}{2 + 4} = 4/3 \Omega$$

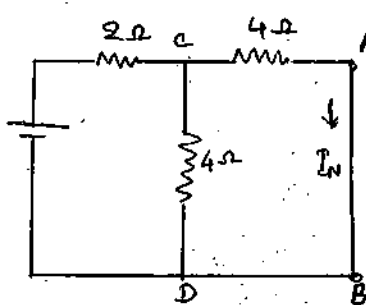

(a)

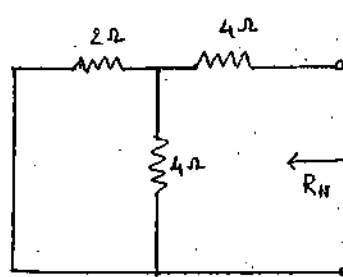

(b)

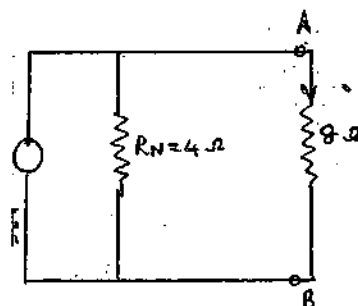

(c)

The resistance between AB is now

$$Z_{AB} = 4/3 + 4 = 16/3 = 5.3 \Omega$$

Fig VII (a) & (b)

And the Thevenin's equivalent of the above network is shown in fig VII b

$$R_{TH} = R_2 + \frac{R_1 R_3}{R_1 + R_3} \quad \& \quad R_{TH} = \frac{1.0(1+0.2) \times 0.8}{0.8+1.2} + 0.48 = 1.48 \Omega$$

$$I_L = \frac{E}{R_{TH} + R_L} = 1.256 \text{ Amp.}$$

Norton's equivalent circuit will be as shown in fig given below

$$I_N = E_{TH} / R_{TH} = 4.8 / 1.48 = 3.24 \text{ Amp.}$$

$$\text{Current in Load } (I_L) = I_N \times \frac{R_N}{(R_N + R_L)} \times L$$

$$R_N = R_{TH} = 1.48 \Omega$$

$$= \frac{1.48}{(1.48 + 3.2)} \times 3.24 = 1.025 \text{ Amp.}$$

Problems to be Solved:

1. A battery of 1.5 volts is connected in series with the resistance of 20 & 30 Ω . Find out equivalent voltage and resistance across the points of 30 Ω resistance. Ans: 0.9v, 12.5 Ω .
2. A battery of emf 6 volts & internal resistance 5 Ω is joined in parallel with another of emf 10 volts & internal resistance 1 ohm the combination is used to send a current through an external resistance 12 Ω . Calculate the current through each battery.

Hint: Apply Kirchoff's II law to two meshes i.e., ABFEA & CDEFC fig. for above problem given beside

$$\text{Ans: } I_1 = 6/11 \text{ Amp.}$$

$$I_2 = 14/11 \text{ Amp}$$

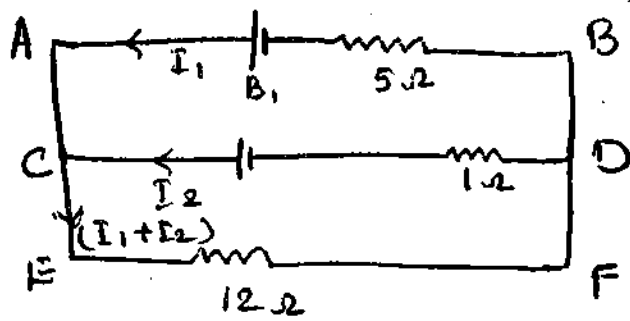
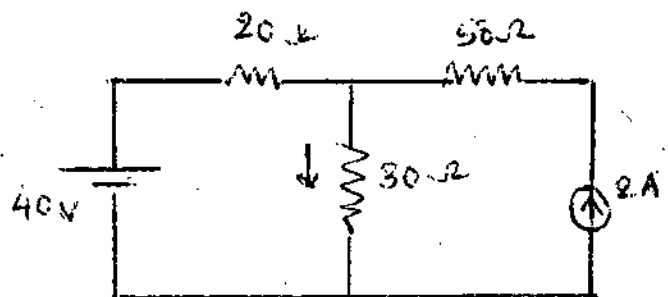
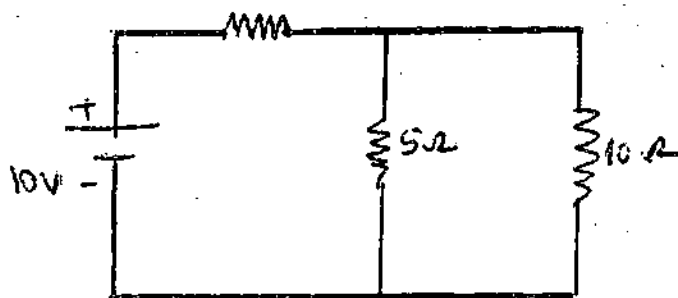

Fig (i)



5 Find the current in 10 ohms resistance in the circuit shown by thevenins theorem.
 Hint : (1) Draw circuit for V_{TH} disconnecting load, the find R_{TH} (2) Draw equivalent circuit and Find current through 10Ω load.



Ans: 0.4 Amps.

6 Draw Thervenin's equivalent circuit for the given network fig. Below & then obtain Norton's circuit.

Hint: 1) Find open circuit voltage when R_L is disconnected i.e $E^1 = 8$ volts. 2) Then find R_L & impudence
 Value = 9Ω then draw Norton's circuit.

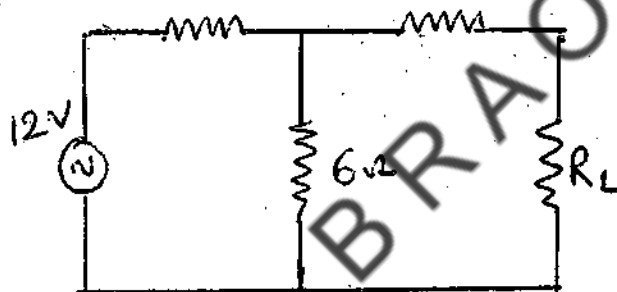

7. Find the thevenins equivalent for the circuit given below

Hint : With A and B open Find P.D across A X B Then resistance between A & B

(2) Then Draw thevenins equivalent of above network.

Ans $V_{AB} = 24 V$
 $Z = 6 \Omega$

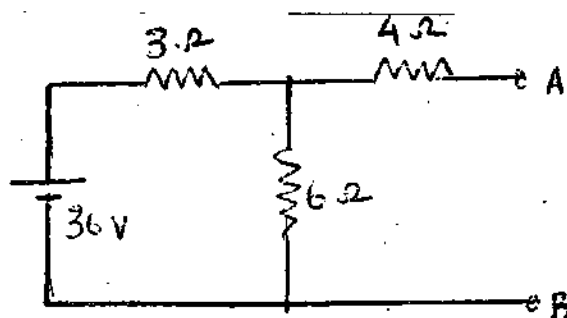

10) Draw the Thevenin's & Norton's equivalent circuits for the following & Norton's of resistance. Calculate the current in the load in each case.

2) Then Thevenin's emf E_{TH} Apply kirchoff's law II to circuit.
Find E_{TH} & R_{TH} by formula.

Then I_L value to be found

3) find $I_N = E_{TH}/R_{TH}$ & I_L by $\frac{R_N}{R_N + R_L} \cdot I$

Ans: $E_{TH} = 12 \text{ V}$

$I_L = 30/11 \text{ Amp}$

$I_N = 10 \text{ Amp}$

$R_{TH} = 1.2 \Omega$

8.11 SAMPLE EXAMINATION QUESTIONS

I. Answer the following questions in detail

1. Superposition principle & Reciprocity theorem – state and prove them
2. In general network what is the use of superposition theorem
3. State and prove Thevenin's theorem
4. State and prove Norton's theorem
5. Define & Compare Thevenin's Norton's Theorems.
6. How is Thevenin's equivalent & Circuit related with the Norton's equivalent circuit.

II Answer the following questions in brief

1. Define the following terms:
a) Network b) Node c) branch
2. Give statements of a) Thevenin's & b) Norton's theorems.
3. State and Explain superposition theorem.
4. State and Explain Reciprocity theorem.
5. Distinguish between the two theorems Norton's & Thevenin's.

BLOCK – 3: MAGNETOSTATICS

BRITOU

UNIT 9: AMPERE'S LAW

Contents

- 9.1 Objectives
- 9.2 Introduction
- 9.3 Magnetic field.
- 9.4 Definition of B.
- 9.5 Ampere's Law
- 9.6 Magnetic field at a point due to a current carrying straight wire
- 9.7 Magnetic lines of Induction
- 9.8 Summary
- 9.9 Model Answers
- 9.10 Sample examination questions

9.1 OBJECTIVES

This unit discusses of magnetic field and the effects associated with them. To help your understand them the Unit explains.

- 1) Oersted's experiment
- 2) Amperes Law

After going through this unit you will be able

- 1) to calculate the magnetic field caused by current carrying straight wire; and
- 2) explain the concept of magnetic lines of induction

9.2 INTRODUCTION

Our knowledge of magnetism and magnetic phenomena is as old as science itself. During the 16th century, the English physician name Gilbert studied the properties of magnets and also realized that a magnetic field existed around the earth. The nature of this field was similar to the magnetic field around a magnetic sphere. In 1820 Oersted discovered that a magnetic field exists around a wire carrying electric current. This basic observation proved the way for producing high magnetic fields.

If there exists both electric and magnetic field, the force on the particle is Lorentz force.

$$\vec{F} = q\vec{E} + q\vec{V} \times \vec{B}$$

9.5 AMPERE'S LAW

When an electric current flows through a conductor three kinds of effects may be produced. They are (1) the magnetic effect, (2) the heating effect and (3) the chemical effect. Any one of these methods can be used to measure the strength of the currents. We shall consider the magnetic effects only.

It was observed by Oersted that a magnetic needle was placed near a current carrying conductor, the needle was found deflected from its north south setting, indicating thereby an electric current produces a magnetic field. Reversing the direction of the current reverse the direction of the magnetic needle.

Laplace and Ampere showed the law for intensity of the field due to a current carrying, linear conductor in a mathematical form. This is referred to as Ampere's Law.

According to this Ampere's law we write the quantitative relationship between current and the magnetic field B as

$$\oint \vec{B} \cdot d\vec{l} = \mu_0 i \quad \dots (9.3)$$

This equation is known as Ampere's law

It is appreciable to know the historical experiment performed by Ampere which led him to formulate above equation. The experiment consists of measuring B at various distances r from a long straight wire of circular cross section and carrying current i .

Let us put a small needle at a distance r from the wire. Such a needle (we may call this as small magnetic dipole) tends to line up with the external magnetic field, with its north pole pointing in the direction of B . The direction of the B is along the tangent to the circle of radius r centered on the wire.

Let us turn the dipole through an angle θ from its equilibrium position. To do this we must exert an external torque τ , which must be able enough to overcome the restoring torque that will act on the dipole.

The torque τ , angle of deflection θ and the magnetic field B are related by an equation, which gives the magnitude of τ .

$$\tau = \mu B \sin \theta \quad \dots (9.4)$$

$$\text{or } \vec{\tau} = \vec{\mu} \times \vec{B} \quad \text{(Vectorial representation)} \quad \dots (9.5)$$

9.6 MAGNETIC FIELD AT A POINT DUE TO A CURRENT CARRYING STRAIGHT WIRE

In a long straight wire carrying a current I as shown in Fig. 9.1 an element dl of the current will produce a magnetic induction dB at a point situated r from it.

$$\therefore dB = \frac{\mu_0}{4\pi} \frac{dl \sin \theta}{r^2} \quad (9.10)$$

Expressing dl , $\sin \theta$ and r^2 in terms of the angle θ
We find that

$$B = \frac{\mu_0 I}{4\pi r} \int_{-\pi/2}^{+\pi/2} \cos \theta d\theta$$

$$B = \frac{\mu_0 I}{2\pi r} \quad \dots (9.11)$$

The magnitude of B thus falls off inversely as the distance from an infinity long wire and is in the direction perpendicular to a plane containing the wire. The lines of induction B are circles lying in a plane perpendicular to the wire and are centered on it.

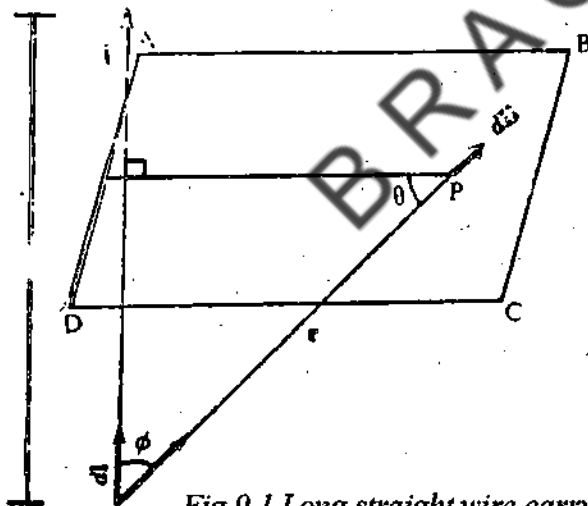

Fig 9.1 Long straight wire carrying current i

9.7 MAGNETIC LINES OF INDUCTION

Suppose AB is a straight wire through which a current is passing upwards. The sense of the magnetic lines of intersection of the card board and the conductor have the common centre. Like wise the lines of induction at any point of the conductor consists of concentric rings with the point at centre.

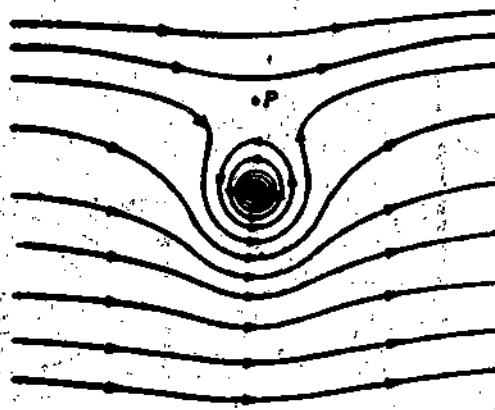

Fig 9.4 Lines of B near a long carrying wire placed in an external field B .

Fig 9.4 shows the resultant lines of magnetic induction associated with a current in a wire, i.e., oriented at right angles to a uniform external field B . At any point the resultant magnetic induction B will be vector sum of B_e and B_i . Where B_i is the magnetic induction set up by the current in the wire. The fields B_e and B_i tend to cancel above the wire and reinforce each other below the wire. At one point i.e., at P ; B_e and B_i cancel exactly. Very near the wire the field is represented by circular lines and it is essentially due to B_i .

Example 1:

A hollow cylindrical conductor of radii a and b carries a current i uniformly spread over its cross section. Show that the magnetic field B for point inside the body of the conductor i.e., $a < r < b$ is given by

$$B = \frac{\mu_0 i}{2\pi(b^2 - a^2)} - \frac{r^2 - a^2}{r}$$

Check this formula for the limiting case or $a = 0$

Solution:

Since the current is spread over its cross section uniformly, the current inside the circle of radius r is given by

$$= i \frac{\pi(r^2 - a^2)}{\pi(b^2 - a^2)}$$

$$= i \frac{(r^2 - a^2)}{(b^2 - a^2)}$$

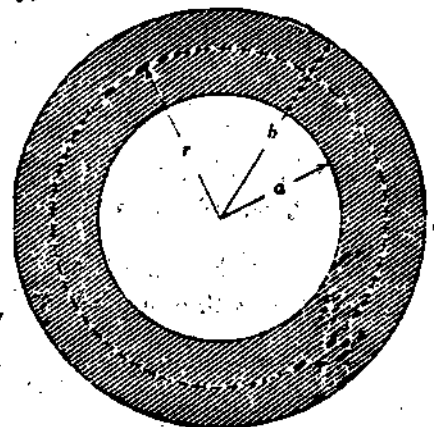

Fig 9.5

The field B for point inside the cross section ($a < r < b$) is given by

$$B = \frac{\mu_0 i}{2\pi(b^2 - a^2)} \frac{(r^2 - a^2)}{r}$$

(Applying Ampere's law)

When $a = 0$, $B = \frac{\mu_0 i r}{2\pi b^2}$

9.8 SUMMARY

Oersted first discovered that a current carrying wire produced magnetic effects.

Magnetic field is a vector and it is denoted by \vec{B} , where \vec{B} is a magnetic induction vector. The number of magnetic lines of induction that pass through the Unit area is known as magnetic flux. It is denoted by ϕB

Check your progress: Answers

1. The unit of magnetic flux is Weber.
2. Ampere's law, $\oint \vec{B} \cdot d\vec{l} = \mu_0 i$

According to this Ampere's law, the magnetic induction along a current carrying conductor is the integral of the element of length carrying current i equal to μ_0 times the magnitude of current flowing through it.

9.10 SAMPLE EXAMINATION QUESTIONS

I Answer the following questions in detail

1. How Ampere's law may be use to calculate the magnetic field at a point due to a long current carrying wire? How do you visualize the magnetic lines of induction of a current carrying wirer?

II. Answer the following question briefly.

1. Write the integral form of Ampere's law
2. What are magnetic lines of induction explain the strength of magnetic field at a
3. point due to a current carrying wire?

Savart's Law. In this chapter you will know how to find the force acting between two conductors carrying current.

10.3 BIOT-SAVART'S LAW

Let AB be a linear conductor through which a current 'i' is flowing. According to Biot-Savart's law the magnetic field at any point P due to a small element dl is

- (i) directly proportional to the elemental dl of the conductor.
- (ii) directly proportional to the strength of the current 'i' flowing the conductor.
- (iii) inversely proportional to the square of the distance 'r' of the element from the point, and
- (iv) directly proportional to the sine of the angle made by the line joining the element to the point with the element.

$$\text{Thus } B \propto i dl \frac{\sin\theta}{r^2} \quad (10.1)$$

'r' is called a displacement vector from the element dl to P and θ is the angle

between this vector and dl. The direction of B is that of the vector $dl \times r$

Thus the Biot-Savart's law may be written in a vector form

$$\vec{dB} \propto \frac{i d\vec{l} \times \vec{r}}{r^3} \quad \dots(10.2)$$

or

$$\vec{dB} = \frac{\mu_0 i}{4\pi} \frac{d\vec{l} \times \vec{r}}{r^3} \quad \dots(10.3)$$

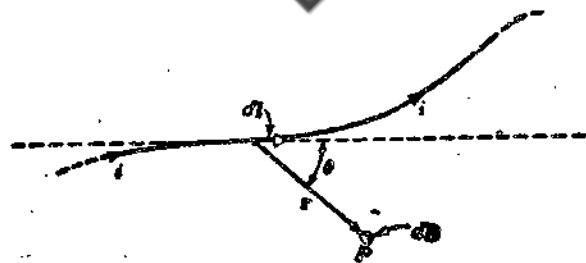

Fig 10.1 a current element dl contributing db at a point P.

The resultant field at P due to the whole length of the wire is found by integrating the Eqn.(10.3)

$$\text{So we obtain } B = \frac{\mu_0 i}{2\pi Z} \dots(10.7)$$

B points out of the page. This is the result we arrived at earlier for this problem. Thus the law of Biot-Savart will always yield results that are consistent with Ampere's law.

10.5 A CIRCULAR WIRE CARRYING CURRENT

We shall find the magnetic field at a distance Z above the center of a circular loop of radius R, which carries a steady current. The field dB attributable to the segment dl points as shown in figure. As we integrate dl around the loop dB describes a cone. The horizontal components cancel, and the vertical components combine to give.

$$B = \frac{\mu_0 i}{4\pi} \int \frac{dl}{r^2} \cos\theta \dots(10.8)$$

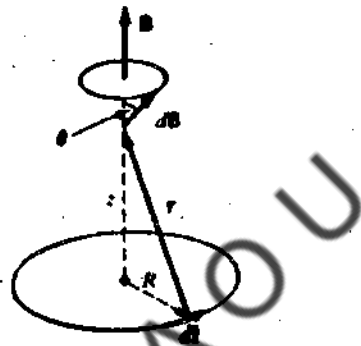

Fig 10.3 A circular wire carrying current

Figure shows that r and theta are not independent of each other. Let us express in terms of a new variable, Z, the distance from the center of the loop to the point P.

The relationships are

$$r = \sqrt{R^2 + Z^2} \dots[10.9(a)]$$

$$\cos\theta = \frac{R}{r} = \frac{R}{\sqrt{R^2 + Z^2}} \dots[10.9(b)]$$

Substituting these values into the expression for B i.e.,

Eqn. (10.8) gives

$$B = \frac{\mu_0 i}{4\pi} \oint \frac{R}{(R^2 + Z^2)^{3/2}} dl \dots(10.10)$$

Integrating this equation, and noting that $\oint dl$ is the simply circumference, $2\pi R$, So

$$B = \frac{\mu_0 i}{2R} = \frac{4\pi \times 10^{-7} \times 15}{2 \times 10^{-1}} = 9.4 \text{ weber/m}^2$$

(b) Torque acting on the small loop at right angles to the first to be given by

$$\tau = N i A B$$

$$\tau = 50 \times 1 \times \pi \times (0.01)^2 \times 30 \pi \times 10^{-6}$$

$$\tau = 1.5 \times 10^{-6} \text{ N.m}$$

10.6 TWO PARALLEL CONDUCTORS CARRYING CURRENTS

Let us now examine the force between two parallel wires a, b carrying currents i_a and i_b separated by a distance d as shown in Fig 10.4

Wire (a) carrying current i_a will produce a field of induction B_a in its surroundings. The magnitude of B_a at the site of second wire is

$$B_a = \frac{\mu_0 i_a}{2\pi d} \quad \dots(10.13)$$

The direction of the B_a at the location of wire b is down as shown in Fig 10.4

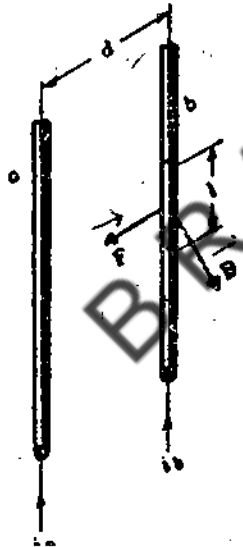

Fig 10.4 Force of attraction between two parallel wires carrying parallel currents.

Wire B is carrying current I_b finds itself immersed in an external field of magnetic induction B_a . The length of this wire b experience a force ($i_l \times B$) whose magnitude is

$$F_b = i_b I B_a$$

$$= \frac{\mu_0 i_a i_b}{2\pi d} \quad \dots(10.14)$$

Hence the wire behaves magnetically almost like a long straight wire and the line of B due to this single turn are almost concentric circles. Thus the solenoid field is the vector sum of the fields setup by all the turns that makes up the solenoid.

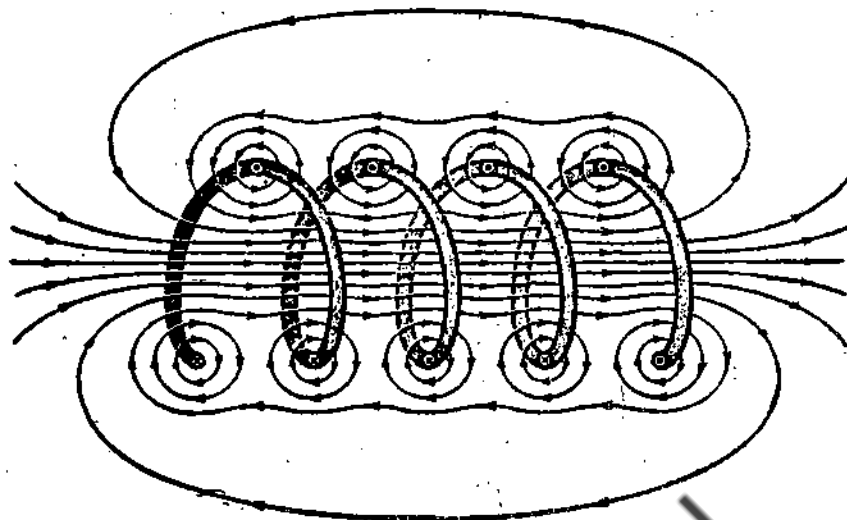

Fig 10.5 (b) Magnetic lines of induction in and around a solenoid.

For the sake of understanding, if we see the induction of a solenoid with widely spaced turns, it suggests that the field partially get cancelled near the wires. It also suggests that B gets reinforced at the center and it is parallel to the solenoid axis for the points which are far from the wires inside the solenoid.

The field setup by the upper part of the solenoid turns points to the left and tends to cancel the field setup by the lower part of the solenoid turns which points to the right. As the length of the solenoid approaches the configuration of an infinitely long cylindrical current sheet, the induction outside the solenoid approaches zero. For practical solenoid, if its length is must greater than its diameter, the field external to the solenoid is weaker or insignificant. For the solenoids whose length is not much greater than the diameter, the external field is much weaker than the internal field.

To calculate the magnetic induction, we take a section of the solenoid as shown in the Fig. 10.5 (c)

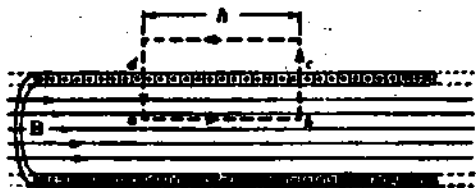

Fig 10.5(c) The field must be zero outside infinitely long solenoid.

Example 1:

Field of a toroid: Fig 10.6 illustrates a toroid wound with N turns of wire carrying current ' i '. The mean radius of the toroid is ' d '.

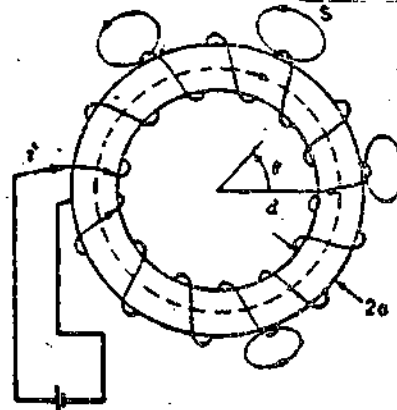

Fig. 10.6 A toroid wound with N turns.

The cross section of the toroid is circular with radius ' a ' much smaller than d , i.e., $A \ll d$;

The tangential field b is continuous across the boundary separating the toroid and the air region just outside but inside the helix winding. Therefore the flux density B in the interior is much greater than that outside the toroid. Thus most of the flux lines are concentrated in the interior as shown in the figure 10.7.

Applying Ampere's law to circular path of integration of radius d

$$\oint \vec{B} \cdot d\vec{l} = \mu_0 i$$

$$B(2\pi d) = \mu_0 i N$$

Where ' i ' is the current in the toroid windings and N is the total number of turns.

$$B = \frac{\mu_0 i N}{2\pi d}$$

Example 2:

Two long wires at a distance ' d ' apart carry equal and antiparallel currents ' i '. Show that B at a point P which is equidistant from the wires.

$$B = \frac{2\mu_0 i d}{\pi(4R^2 + d^2)}$$

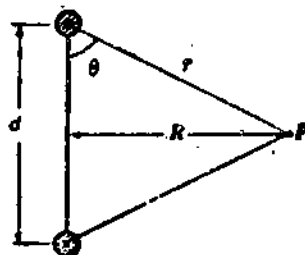

Fig 10.7

The field directions are shown in figure, only the vertical components reinforce each other the cross section of wires from a square.

$$B = \text{near the point } p = 4 \times \frac{\mu_0 i}{2\pi a/\sqrt{2}} \cos\theta$$

$$= \frac{4 \times 4\pi \times 10^{-7} \times 20}{2\pi \times 0.2/\sqrt{2}} \frac{1}{\sqrt{2}} = 8 \times 10^{-5} \text{ weber/m}^2$$

Example 4:

A solenoid 1 meter long and 3.0 cm in mean diameter. It has five layers of windows 850 turns each and carries a current of 0.5 Amp. What is B at the center?

Solution:

$$\begin{aligned} B &= \mu_0 i n \\ &= 4\pi \times 10^{-7} \times 5 \times 5 \times 850 \\ &= 2.7 \times 10^{-2} \text{ Weber/m}^2 \end{aligned}$$

10.8 SUMMARY

The magnetic field at any point due to a small elemental length of the conductor is directly proportional to the elemental length of the conductor, strength of the current flowing through the conductor, sine of the angle made by the line joining the elemental length of the conductor to that point and elemental length and inversely proportional to the square of the distance between the reference point and the elemental length of the conductor.

There will be attractive force between the parallel wires carrying currents in the same direction while the force is repulsive if the direction of currents are opposite. The resultant force per unit length between two current carrying parallel wires is given by $\frac{F}{l} = \frac{\mu_0 i_a i_b}{2\pi d}$

The magnetic induction of a solenoid depends upon the number of turns n, wound on the solenoid and the current 'i' passing through the solenoid.

$$B = \mu_0 n i$$

Check your progress: Answers

$$1. \quad dB = \frac{\mu_0 i}{4} \frac{dl \times r}{r^3}$$

$$F_{\text{max}} = qVB \quad \dots(11.1)$$

In the equation 11.1 except q all other quantities are vector quantities. Hence a vector definition of B may be defined as follows:

If a positive test charge q is fired with a velocity V through a region and if a sideways deflecting force F is experienced by the moving charge then a magnetic induction B is present at that region satisfying the relation.

$$\vec{F} = q\vec{V} \times \vec{B} \quad \dots(11.2)$$

i.e $F = QVB \sin \theta$ where θ is angle between V and B as shown in figure. ... (11.3)

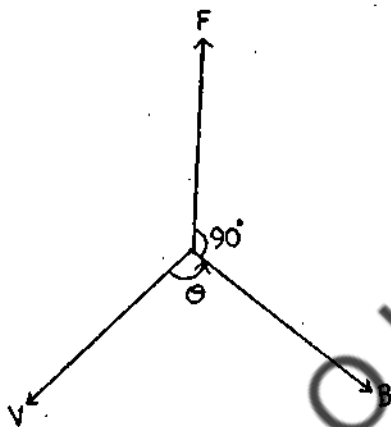

Fig 11.1. Vectorial representation of $\vec{F} = q\vec{V} \times \vec{B}$

If a charged particle moves through a region where an electric field E and a magnetic induction B are present then the resultant force experiencing by the moving charge is

$$\vec{F} = q\vec{E} + q\vec{V} \times \vec{B} \quad \dots (11.4)$$

This equation is known as Lorentz force equation.

11.4 MAGNETIC FORCE ON A CURRENT

A current in a wire may be visualized as assembly of moving charges. Hence if a current carrying wire is placed in magnetic field a force of the Lorentz type will act in the wire. We shall calculate this force on the wire.

Let a wire of length l carrying a current I be placed in a magnetic field of strength B. This direction of current density vector J and magnetic field vector B are taken to be perpendicular to each other.

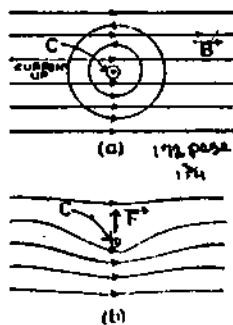

Fig 11.2(a) & (b)

10.10 RECOMMENDED BOOKS

- | | | |
|---|---|--|
| 1. Kraus, J.D and Carver, K.R | Electromagnetics | Mc Graw-Hill
Kognakusha Ltd., Tokyo |
| 2. Corsan, D.R. and Lorrian, P | Introduction to
Electromagnetic
Field Waves | Freeman Toppa,
London. |
| 3. Griffiths, D.
Electromagnetic | Introduction to
New Delhi. | Prentice-Hall of India |
| 4. Plonsey, R. and Collin, R.E. | Principles and
Applications of
Electromagnetic fields | Mc Graw -Hill
Publishing Company Ltd.
New Delhi. |
| 5. Laud, B.B | Electromagnetics | Wiley Eastern Ltd.,
New Delhi. |
| 6. Halliday, D. and | Physics -Part II | Wiley Eastern Ltd.
New Delhi. |
| 7. Grant, I.S. and | Electromagnetism | John Wiley & Sons,
Chichester. |
| 8. Wenham, E.J.,
Dorling, G.W.,
Snell, J.A.N. and
Taylor, B. | Physics concepts
and models | Addision-Wisely
Publishers Ltd.
London. |

When a current loop is placed parallel to a magnetic field the force acts on the loop in such a way that it tends to rotate the loop. The product of tangential force and the radial distance at which it acts is called the torque; or mechanical moment on the loop. Torque (or mechanical moment) has the dimensions of force times distance and is expressed in Newton Meters.

Consider the rectangular loop as shown in figure 11.3 (a) with sides of length l and d placed in a magnetic field of uniform flux density B . The loop carries a steady current i .

As per the equation (11.8) the force on any element dl of loop is

$$\vec{dF} = i d\vec{l} \times \vec{B} \quad \dots(11.8)$$

If the plane of the loop is at an angle θ with respect to B as indicated in the cross-sectional figure 11.3(b) then the tangential force $F_t = |F| \cos \theta$

$$F_t = iB \cos \theta \int_0^l dl \quad \dots(11.10)$$

$$= iBl \cos \theta$$

The total torque on the loop is then

$$T = 2F_t \frac{a^1}{2}$$

$$= iBl d \cos \theta$$

Since $id = A$ the torque

$$\text{So } \tau = IAB \cos \theta \quad \dots(11.11)$$

Hence according to equation 11.11, the torque is proportional to the current in the loop, to its area and to the flux density of the field in which the loop is situated.

The product of I and A in equation (11.11) is designated as the magnetic moment or magnetic dipole moment of the loop μ

$$\text{With } \mu = N iA$$

Where N is the number of turns in the loop

$$\text{Then the torque } \tau = \mu B \cos \theta$$

$$\text{Or } \tau = \mu B \sin \alpha \quad \dots(11.12)$$

Where α is the angle between the normal to the plane of the loop and the direction of B (See figure 11.3 (b))

Examples:

1. A wire of 60cm length and mass 10 grams is suspended by a flexible leads in a magnetic field of induction 0.40 weber/meter². What are the magnitude and direction of the current required to remove tension in the supporting leads?

The weight of the wire = $mg = 0.01 \times 9.8 = 9.8 \times 10^{-2}$. In order to have no tension in the leads, the force acting on the wire must be equal to the weight of the wire

$$mg = ilB$$

$$i = mg/lB = 9.8 \times 10^{-2} / 0.6 \times 0.4 = 0.41 \text{ Amp}$$

$$i = 0.41 \text{ Amp}$$

2. A rectangular loop of a wire having sides 10cm, 5cm, carries a current of 0.10 Amp and is hinged at one side. What torque acts on the loop if it is mounted with its plane at an angle 30° to the direction of a uniform field of magnetic induction 0.50 webers/m²

$$\text{Force on the conductor} = F = NiB \times l$$

$$= 20 \times 0.1 \times 0.5 \times 0.1$$

$$= 0.1 \text{ N}$$

$$\tau = F \times 0.05 \cos 30^\circ$$

$$\tau = 0.1 \times 0.05 \times \cos 30^\circ$$

$$\tau = 4.3 \times 10^{-3} \text{ N}$$

11.6 SUMMARY

When the moving charge is placed in magnetic field, it produces a torque on the moving charge.

Check your progress: Answers

1) Force exerted is given by $F = ilB$ (Where B is the magnetic field intensity & 'i' is the current flowing through a conductor of length l)

2) The torque on a current loop is given by $\tau = \mu \cdot B$ (Where μ is the permeability of the medium.)

UNIT 12: MOTION OF CHARGED PARTICLES

Contents

- 12.1 Objectives
- 12.2 Introduction
- 12.3 Charged particles in electric fields
- 12.4 Cyclotron
- 12.5 Hall effect
- 12.6 Determination of charge of an electron by Millikan's Oil Drop Method
- 12.7 Thomson's experiment
- 12.8 Summary
- 12.9 Sample examination questions

12.1 OBJECTIVES

This Unit discusses the effects of electric and magnetic fields on electric charges at rest or in motion. To make you understand the effect the basic principles are illustrated.

After going through this Unit you should be able to make out the energy of the particle moving through the electric field would increase and that the motion of charged particles along the lines of force in the uniform magnetic field would not be effected.

12.2 INTRODUCTION

In this unit we will discuss the motion of a charged particle in electric and magnetic fields.

In the period between 1914 and 1916 a controversy has arisen between F. Ehrenhaft and H.A. Millikan about the elementary nature of electron. In 1897 J.J. Thomson showed cathode rays to consist of a stream of negatively charged particles. In the early part of 1897 E. Wiechert and W. Kaufmann in Germany reported results of their measurements on the path of cathode rays in a magnetic field. Kaufmann found that the value of charge to mass ratio (e/m) for cathode ray particles was the same regardless of the nature of gas present in the discharge tube. Wiechert compared this e/m value with those calculated for a hydrogen ion in solution and concluded the particles had a mass of approximately that one-thousandth part of a hydrogen atom. At a later date J.J. Thomson made similar studies. His experiments became classical even though are not of great accuracy.

$$y = \frac{1}{2} at^2 = \frac{qEt^2}{2m} \quad \dots(12.4)$$

$$V^2 = 2ay = \frac{2cEx}{m} \quad \dots(12.5)$$

The kinetic energy attained by the charge particle after moving a distance 'y' is

$$\begin{aligned} \text{K.E.} &= \frac{1}{2} mV^2 \\ &= \frac{1}{2} m \frac{(2qEy)}{m} \\ &= qEy \\ &= q^2 E^2 t^2 / 2m \quad \dots(12.6) \end{aligned}$$

Case (2): The charged particle in a uniform electric field (initial velocity being not zero)

Fig 12.2 shows the path of a charged particle of mass 'm' and charge 'q' moving with velocity V_0 at right angles to the uniform electric field E along 'y' direction. We will show that the motion of such charge particle will be parabolic as long as it is in the field. As the electron emerges out of the field, it travels in a straight-line tangent to the parabola at the exit point. The general motion of the particle can be described in terms of its motion along the horizontal direction by

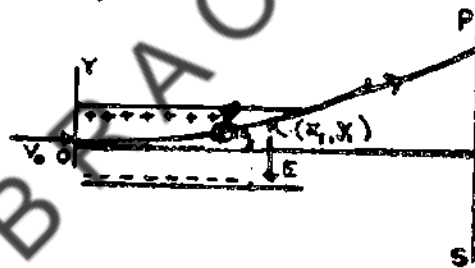

Fig 12.2

$$X = V_0 t \quad \dots(12.7)$$

And the displacement along the vertical direction can be shown to be (using Eqn. 12.4)

$$Y = \frac{1}{2} at^2 = \frac{qEt^2}{2m} \quad \dots(12.8)$$

Combining the equations 12.7 and 12.8 we get

$$Y = \frac{(qE \cdot 2m V_0^2) X^2}{2m V_0^2}$$

Which shows that the path of the particle is a parabola.

Example 1:

An electron moving with a speed 5.0×10^8 cm/sec is shot parallel to an electric field strength 1.0×10^3 N/coul (a) How far will the electron travel in the field before

$$= \frac{(1.2 \text{ Weber/m}^2)(1.60 \times 10^{-19} \text{ coul})}{1.67 \times 10^{-27} \text{ kg}}$$

$$= 1.15 \times 10^8 \text{ sec}^{-1} \quad (\text{i.e. rad/s})$$

The corresponding frequency (in Hz) is

$$= \omega / 2\pi = 1.83 \times 10^7 \text{ sec}^{-1}$$

$$(b) \ qVB = mV^2/r$$

$$V = qBr/m$$

$$K.E = \frac{1}{2} mV^2$$

$$= \frac{1}{2} m (qBr/m)^2$$

$$= \frac{1}{2} q^2 B^2 r^2 / m$$

$$= \frac{1}{2} (1.60 \times 10^{-19} \text{ coul})^2 (1.2 \text{ web/m}^2)^2 (0.1 \text{ m})^2 \times$$

$$= \frac{1 \text{ eV} / 1.60 \times 10^{-19} \text{ coul}}{1.67 \times 10^{-27} \text{ kg}}$$

$$= 1.7 \times 10^7 \text{ eV}$$

$$= 17 \text{ MeV}$$

Example 3:

A 5.0 cm length of wire carries a current of 3.0 Amp. There is a uniform B field of magnitude 10^{-13} Weber/m², whose direction is shown in the diagram. Calculate the magnetic force exerted on the wire.

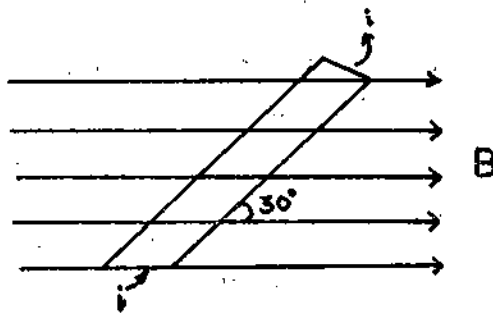

Fig 12.5

Case (i) consider a charge in motion with a velocity V at right angles to a magnetic field of strength B . Then time t taken by it over a distance l is $t = l/V$. The motion of charged particle constitutes a current i

$$it = q$$

$$i = q/t = \frac{q}{l/V} = \frac{qV}{l}$$

$$\text{or } il = qV$$

But the force on this current element from equation

$$F = Hil = BqV \quad \dots (12.9)$$

Fig 12.3 shows a negatively charged particle introduced with a velocity V into the uniform magnetic field of induction B . We assume that V is at right angles to B and thus the motion lies entirely in the plane of the figure. The relation $F = qVB$ shows that the particle will experience a side ways deflecting force of magnitude qVB . This force will lie in the plane of the figure, which means that the particle cannot leave this plane.

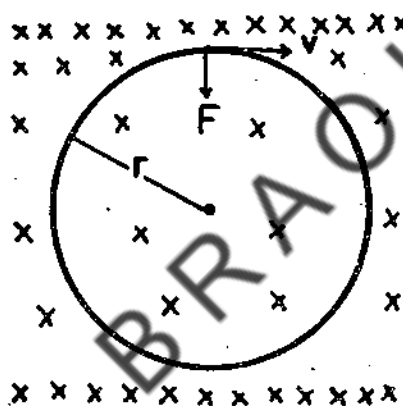

Fig 12.3

Having defined the force, the kinematic relation can be shown as follows:

$$qBV = \frac{mV^2}{R} \quad \dots (12.10(a))$$

$$\text{or } R = \frac{mV}{qB} \quad \dots (12.10(b))$$

Which gives the radius of the path.

The angular velocity ω is given by V/r from equation 12.9 we have.

The frequency ν measured in Hertz is given by

$$\omega = \frac{V}{r} = \frac{qB}{m} \quad \dots (12.11)$$

Which does not depend upon the speed of the particle or the radius of its orbit. The particle goes around the circle in period time that varies only with mass and charge and with magnetic field.

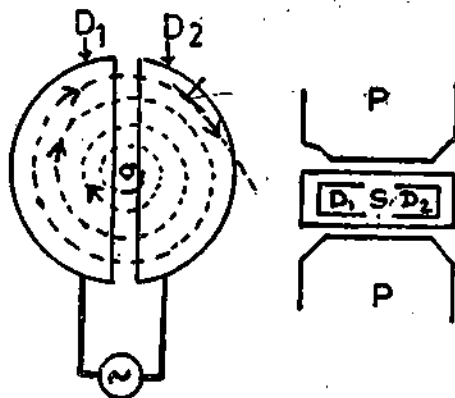

Fig 12.6 cyclotron

P = Magnetic/ pole pieces

S = High frequency oscillator

D₁D₂ = Deflectors

Fig 12.6 is a sketch of a cyclotron. The magnetic field is directed upwards as shown. The Dees' (so called because they are like a letter D) are hollow copper boxes that are connected to a source of alternating potential (called an Oscillator) that their polarity changes regularly. When a charged particle, for instance a proton, is injected into the space between the Dees from a suitable source, it is attracted by the Dee that is negative since its own charge is positive. Within the Dee's the magnetic fields compels the proton to travel in a semicircle, as in Fig 12.6. When it comes out a t other side, if the alternating current has the proper frequency, the opposite D will be negative and the proton will be accelerated across the gap between Dee's. Then it circulates with in the second Dee and again receives acceleration when it emerges and so on. Ultimately the proton has sufficient energy to leave the cyclotron, through the opening shown. The principle of the cyclotron is to use a relatively small electric field to accelerate charged particles by causing them to be acted upon by the field repeatedly. If the period of the oscillator is exactly equal to the period of the protons in the magnetic field they will always be attracted to the opposite Dee when they reach the gap between the Dees even though their speed (and the radius of their orbit) is greater each time they arrive there.

The accelerated particles are usually protons, deuterons, and particles. The energy acquired will depend upon the size of the Dees as the maximum velocity will correspond to the path of the radius equal to that of Dees

$$V_{\max} = \frac{BqR_d}{m}$$

(where R_d is the radius of the Dee)

$$E_{\max} = \frac{1}{2} V_{\max}^2$$

$$= \frac{1}{2} m \left(\frac{BqR_d}{m} \right)^2$$

12.5 HALL EFFECT

We have seen that a metallic conductor carrying a current placed in a magnetic field, experiences a force tending to make it move in a direction, perpendicular both to the direction of the current and to that of the field. If the conductor is fixed the moving charged particle, constituting the current should be displaced within the conductor under the action of transverse magnetic field. This then should lead to the potential difference, when a current is passed along a strip of metal foil, and when the magnetic field, perpendicular to the plane of the foil is applied, a measurable transverse emf called the Hall voltage was set up between the points on the opposite edges of the foil. Figure 12.7 shows the arrangement to observe Hall voltage.

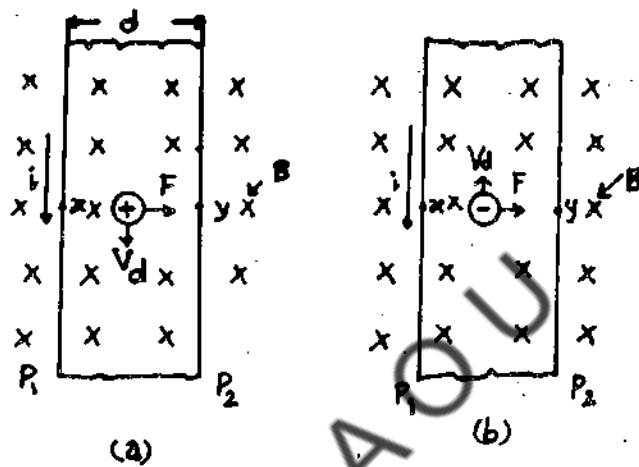

Fig 12.7 Hall effect

If the current is due to the motion of electrons moving upwards (i.e. in the direction opposite to the conventional current), then applying Fleming left hand rule to the conventional current as shown in Fig 12.7 the force on the charge carriers is towards the edge P_2 and the electrons are moved toward P_2 , making it negative while the edge becomes positive. Thus an emf set up between P_1 & P_2 Hall was able to show that the current in a metal is the result of negatively charged particles i.e. electrons.

From the above discussion it follows that hall Voltage is due to the transverse force on the carries in the conductor.

If

q is charge o reach carrier and

V the velocity of drift charge along the conductor

N the No. of charged particles per unit volume

B the magnetic field intensity

Then the electric field intensity E set up by hall Voltage between P_1 & P_2 in equilibrium,

Since $F = 0$ is given by

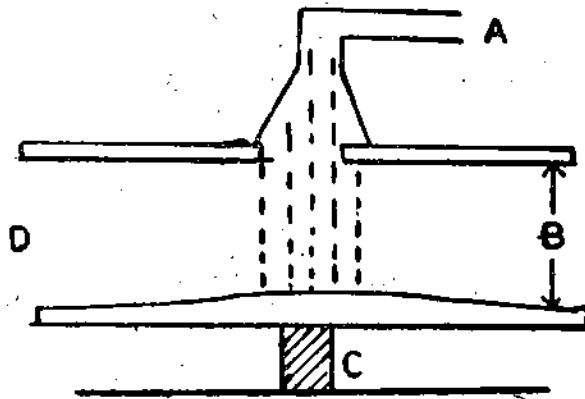

Fig. 12.8

When such a drop falls the influence of gravity, it is hindered by the air it passes through. The way in which the fall of small spherical body is hindered by air had been described by Stokes, who found that such a body experiences a resisting force R proportional to its velocity.

$$R = KV \quad \dots (12.15(a))$$

The proportionally constant K was found by Stoke's expression involving coefficient of viscosity of the resisting medium and the radius of the body.

A falling droplet of oil is acted as on by its weight W , the buoyant force F_B of the air. And the resisting force $R = KV$ (Fig 12.8). The resultant downward force F is

$$F = W - F_B - KV \quad \dots (12.15(b))$$

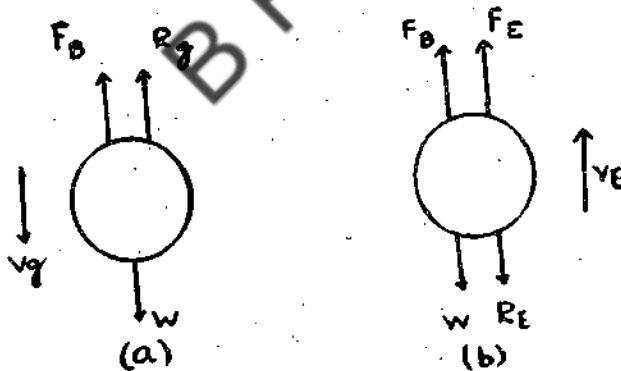

Fig 12.9 a) on falling down b) on moving up

Initially the velocity V is zero, the resisting force is zero, and the resulting downward force equals to $W - F_B$. The drop therefore has an initial downward acceleration. As its downward velocity increases the resisting force increase and eventually reaches a value such that the resultant force is zero. The drop then falls with a constant velocity called terminal Velocity, V_g since $F = 0$, $V = V_g$, we have from equation (12.8)

$$W - F_B = KV_g \quad \dots (12.16)$$

$$E = 300 \text{ Volts/cm}$$

$$= 30,000 \text{ Volts/m}$$

$$m = 9.75 \times 10^{-12} \text{ g}$$

$$= 9.75 \times 10^{-15} \text{ kg}$$

$$\text{and } g = 980 \text{ m/s}^2$$

$$\text{here } qE = mg$$

$$q = \frac{mg}{E} = \frac{9.75 \times 10^{-15} \times 9.8}{30,000}$$

$$= 31.85 \times 10^{-16} \text{ Coulombs}$$

Example 2:

A charged oil drop is prevented from falling under gravity by a vertical electric field between two horizontal metal plates charged to a potential difference 6920 V, the distance between the plates being 1.3 cm. When the field is cut off the drop falls in air with uniform velocity of 1.9×10^{-11} m. Calculate (a) the radius of the drop (b) charge on the drop?

$$\text{Density of oil} = 0.9 \times 10^3 \text{ kg/cm}^3$$

$$\text{Coefficient of viscosity of air} = 1.81 \times 10^{-4}$$

The density of air may be neglected in comparison to that of oil.

(a) Substituting the given values

$$a = \frac{9 \times 1.81 \times 10^{-4} \times 1.9 \times 10^{-11}}{9 \times 9.81 \times 0.9 \times 10^3}$$

$$= 1.75 \times 10^{-6} \text{ m}$$

(b) $qE = (4/3)\pi a^3$

$$\text{Hence } E = \frac{6920}{1.2 \times 10^{-2}} \text{ Volt/m}$$

$$q \times \frac{6920}{1.2 \times 10^{-2}} = \frac{4}{3} (7.75 \times 10^{-6})^3 \times 0.9 \times 10^3 \times 9.81$$

solving we get

$$e = 4.042 \times 10^{-19} \text{ Coulombs}$$

$$E = vB \quad \dots (12.24)$$

e = electrical and q being designated as the charge of the electron.

Equation 12.24 shows that for a given value of V , the zero deflection can be achieved by adjusting the value of E and B . The main points in Thomson's method can therefore be summarized under.

1. The position of the undeflected beam on the screen is noted when electric and magnetic fields zero.
2. The deflection on the fluorescent screen is then noted when a fixed electric field E is applied, and
3. Finally the magnetic field B is applied and its value adjusted until deflection of the electron beam is back to zero.

12.8 SUMMARY

The energy of the charged particle increases when it is moving along the electric lines of force. When the charged particle is moving in a magnetic field the force acting on the particle is always normal to the field direction. The motion of the particle is unaffected when the charged particle is moving along the field direction.

Check your progress: Answers

1. Cyclotron.
2. $E = \frac{V_H}{B_d} = B v$

12.9 SAMPLE EXAMINATION QUESTIONS

I Answer the following Questions in detail

1. Describe experiment for the determination of e/m an electron.
2. Discuss the effect of electric and magnetic field o electric charge at rest and at motion.
3. Discuss the application of these effects.

II. Answer the following Questions briefly

1. What is Hall effect?
2. Describe Millikan's oil drop method.
3. Give the principle underlying the determination of e/m an electron.

UNIT – 13: ISOTOPES AND THEIR MASSES

Contents

13.1 Objective

13.2 Introduction

13.3 Aston's mass Spectrograph

13.4 Dempster's mass spectrograph

13.5 Bain bridge mass spectrograph

13.6 Summary

13.7 Sample examination questions

13.1 OBJECTIVES

This unit explains the methods of isotopic separation of atomic masses and the determination of atomic masses through the use of Aston's and Dempsters mass spectrographs.

After going through this unit you should be able to calculate the isotopic content of atomic masses.

13.2 INTRODUCTION

Goldstein in 1886 observed streams coming out of perforated cathode in cathode ray tube. Since the particles associated with these rays were positive, they were called as positive rays. The particles of the positive rays are generated in the space between cathode and anode. These are essentially the positive ions which are created by the cathode particles striking the atoms and molecules of the gas in the tube. The masses of ions are the same as those of atoms and molecules and are very heavy compared to cathode rays. Thus if gas contains some impurities, the positive rays would consist of ions of all the gases unlike the cathode rays which are electrons purely.

The analysis of these ions which yields information about the actual composition of the gas is an important branch of study called the mass spectrograph.

13.3 ASTON'S MASS SPECTROGRAPH

Principle

Aston's mass spectrograph is an apparatus of high accuracy to determine the isotopic masses. The principle and working of the instrument differs from that of Thomson. In that the electrical and magnetic fields are co-terminus and do not act in the same region of

produced by the electric field but recombines the particles which are brought to focus in the form of sharp lines on a photographic plate (detection system) CD. The lines are similar to the lines of the spectrum.

Considering that the deflection in electrostatic field is small and near the vertex may be considered as circular for radius r , we have

$$eE = \frac{mV^2}{r}$$

$$\text{or } \frac{1}{r} = \frac{Ee}{mV^2}$$

Where E = Electric field, m = mass, V = velocity of the particle and e is the charge.

Hence the deflection θ , which is proportional to $1/r$ is given by;

$$\theta = C \frac{Ee}{mv^2} = C_1 \frac{e}{mv^2}$$

$$\text{where } C_1 = cE$$

$$\therefore \text{dispersion } \frac{d\theta}{dv} = -2 C_1 \frac{e}{mv^3} = -2 \frac{\theta}{v} \quad \dots(13.1)$$

if r^1 is the radius of curvature in the magnetic field then

$$Bev = \frac{mv^2}{r^1} \quad (\text{or}) \quad \therefore \phi = C_1 \frac{Be}{mv}$$

$$\frac{1}{r^1} = \frac{Be}{mv} \quad \therefore B \text{ is constant}$$

$$= C_2 \frac{e}{mv}$$

where $C_2 = C_1 B$
again dispersion

$$\frac{d\phi}{dv} = -C_2 \frac{e}{mv^2} = -\frac{\phi}{v} \quad \dots(13.2)$$

from equation 13.1 & 13.2 we have

$$\frac{d\theta}{\theta} = 2 \frac{d\phi}{\phi} \quad \dots(13.3)$$

Thus for a given deflection the dispersion due to the electrical field is twice that of magnetic field. The small changes $d\theta$ and $d\phi$ refer to the particles with identical mass and

Comparing equations 13.7(b) and 13.8 it is observed that the two equations are same when $\alpha = \theta$. This focusing condition is that the photographic plate must be placed at an angle θ with the direction of the incident positive ray beam.

Thus we find in Aston's apparatus

- (i) All the particles of same e/m are brought to the same focus irrespective of their velocities.
- (ii) Particles of different masses are brought to the different foci

Aston investigated positive rays from various different elements and found that the relative masses of atoms were more or less integers. Integers are found to contain atoms having two or more different masses proportional to integers and also with different abundances. Xenon with atomic weight 130.2 is found to be a mixture of atoms of atomic weights 128, 129, 130, 131, 132, 134 and 136, which are all isotopes of Xenon.

13.4 DEMPSTER'S MASS SPECTROGRAPH

Dempster's method is unique in the sense that in addition to the mass identification it is also possible to find the relative abundances of various isotopes of a given element. The positive ions are produced in an evacuated chamber by heating a platinum strip, coated with salt of element under observations and bombarding the vapor with electrons from a filament. All the ions are accelerated by the electrostatic field to the same energy by allowing them to pass through a constant potential difference and are then subjected to the magnetic field perpendicular to the plane of the paper, where by they travel in a circular path.

The ions traversing the same circle of radius emerges out at the slits (13.2) and are collected at E, connected to the electrometer. We have the following relationship.

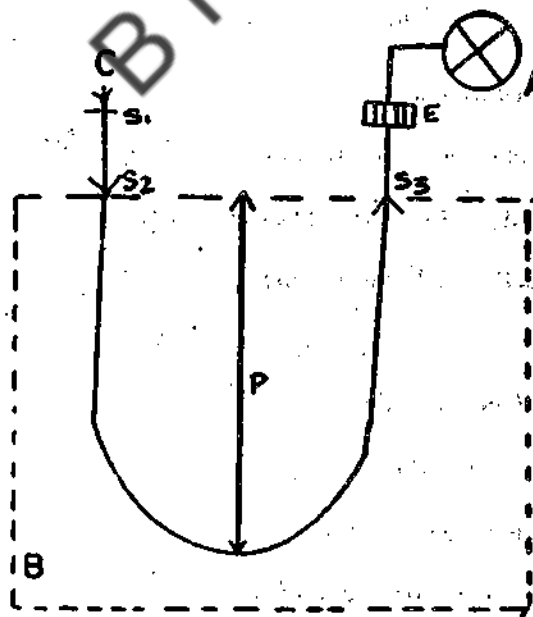

Fig 13.2 Dempster's Mass Spectrograph

- A= Electrometer
- B= Magnetic field
- C= Positive ion

$$Bev = mv^2 / r$$

$$\text{Or } r = \frac{mv}{Be}$$

$$= \frac{9.0 \times 10^{-31} \times 1.7 \times 10^7}{2 \times 10^{-3} \times 1.6 \times 10^{-19}}$$

$$= 4.78 \times 10^{-2} \text{ m}$$

13.5 BAIN BRIDGE MASS SPECTROGRAPH

For determination of isotopic masses the apparatus for this purpose is shown in figure below Fig. 13.4

The beam of +ve ions produced in a discharge tube is collimated by two slits S_1 & S_2 and enter a velocity selector. The velocity selector consists of (1) a steady electric field 'X' maintained at right angles to the ion beam between two plane parallel plates P_1 & P_2 and (2) a magnetic field B.

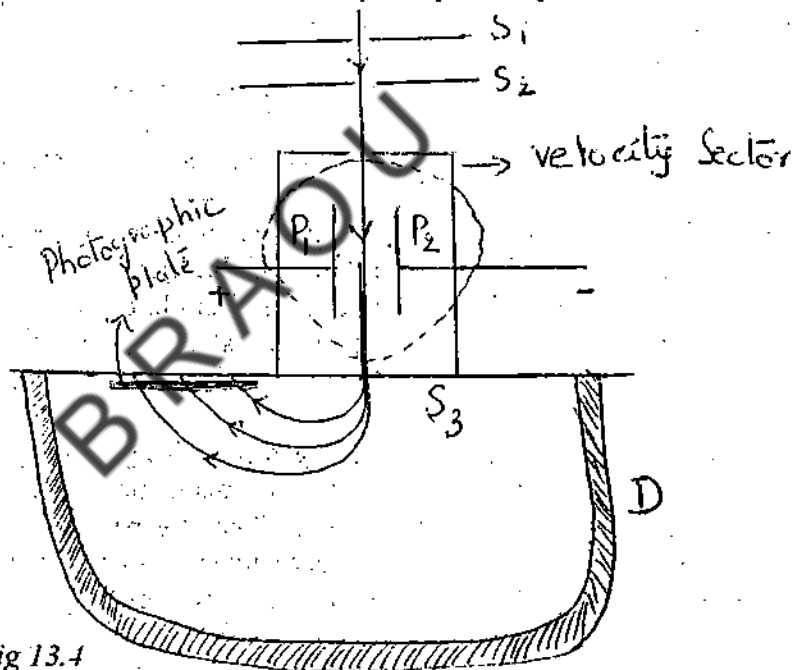

Fig 13.4

The magnetic field is produced by an electromagnet represented by the dotted circle. The magnetic field is perpendicular to X and the ion beam. The electric field and magnetic field of the velocity selector are so adjusted that the deflection produced by one is nullified by the deflection produced by the other. If X and B are the electric intensity and magnetic induction, then,

$$Xe = Bev \text{ or } V = X/B \quad \dots(13.10)$$

Only those ions, having this velocity V, alone pass through the entry slit S_3 to enter the evacuated chamber D. Thus all ions entering D must have the same velocity. The positive, ions which enter into D are subjected to a strong uniform magnetic field of intensity B, perpendicular to its path. The force acting on each ion will be Bev . Ions with different masses trace circular paths of different radii given by

13.6 SUMMARY

Separation of atomic masses on the basis of specific charges were described and the isotopic abundance of atomic masses were calculated.

13.7 SAMPLE EXAMINATION QUESTIONS

I. Answer the following questions in detail.

1. How are isotopic masses separated?
2. Discuss the principle and application of Aston's experiment.
3. Determine the isotopic masses by using Bainbridge mass Spectrograph.

II. Answer the following questions briefly

With a neat sketch explain the principle of Dempster's mass spectrograph.

BRAOU

The growth of the current through the coil produces a change in the magnetic flux linked with the coil. According to Lenz's law an emf gets induced in the coil, which opposes the applied emf. The induced emf lasts as long as the current is growing and decaying.

The emf induced in a closed circuit at make and the break of the circuit is called the emf due to self-induction or self-induced emf. The finite time of growth or decay depends on the flux linkage through the coil and in turn it is also dependent on coil shape. The coils of the nature and shape are known as inductors.

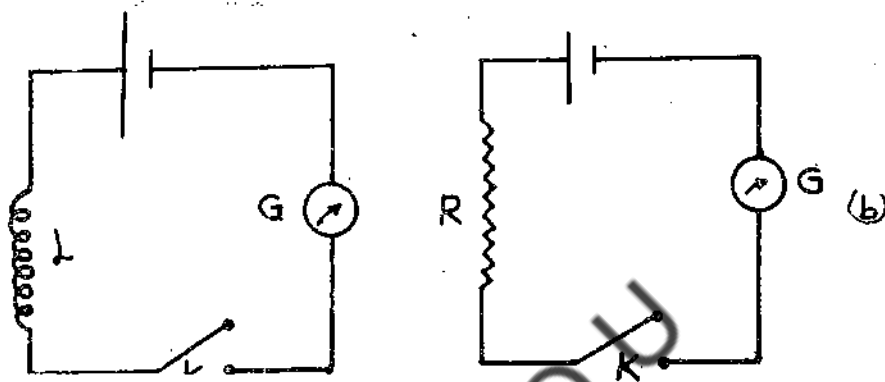

Fig 14.1 (a) and Fig 14.1 (b)

Coefficient of self induction

Consider a long solenoid having N number of turns and the flux associated with each turn is ϕB .

According to Faradays law of induction, the induced emf is given by

$$\varepsilon = \frac{-d(N\phi B)}{dt} \quad \dots (14.1)$$

Where $(N\phi B)$ is the total flux linkage. For a given coil the flux linkage ϕB is given as

$$N\phi B \propto I$$

$$\therefore N\phi B = Li \quad \dots (14.2)$$

Where L is the proportionality constant and is called coefficients of self-induction or inductance of the inductor.

Combining equation 14.2 and 14.1

$$\text{We get that } \varepsilon = \frac{-d}{dt} [N\phi B]$$

$$\varepsilon = -L \frac{di}{dt} \quad \dots (14.3)$$

The magnitude of this induced emf in S will depend upon the amount of flux linked in S. In turn the magnetic flux will depend upon the strength of the current in P. It is observed that $N\phi_B \propto i$

$$N\phi_B = Mi \quad \dots\dots\dots 14.5$$

Where the proportionality constant M is called coefficient of mutual induction or mutual Inductance. The value of M depends on the distance between the coils and on the magnetic property of the medium in which the coils are placed.

Differentiating equation 14.5 from eqn 14.1

$$\frac{d}{dt} (N\phi_B) = M \frac{di}{dt}$$

$$\therefore -\epsilon = M \frac{di}{dt}$$

$$\therefore M = -\epsilon / \frac{di}{dt} \quad \dots(14.6)$$

Thus the coefficient of mutual induction is said to be one unit, if the emf induced is one volt, when the current in the other coil is changing at the rate of 1 amp per second.

The practical unit of mutual induction is henry.

14.5 CALCULATION OF INDUCTANCE OF A SOLENOID

It is possible to calculate the self inductance L for a solenoid
For an inductor

$$L = \frac{N\phi_B}{i} \quad \dots(14.7)$$

Let us consider a solenoid having n number of turns per unit length, consisting length l and correctional area A

$$\therefore \text{the flux linkage } N\phi_B = n l B A$$

Where B is the magnetic induction giving flux B
We know the magnetic induction B for a solenoid

$$B = \mu_0 n i A \quad \dots(14.8)$$

Combining the equations

$$N\phi_B = n l \mu_0 n i A$$

$$N\phi_B = n^2 l i A \quad \dots(14.9)$$

The inductance of a solenoid

14.6 SUMMARY

The coefficient of self-conduction is ϵ

$$\epsilon = -L \frac{di}{dt}$$

— The coefficient of Mutual conduction is

$$M = -\epsilon \frac{di}{dt}$$

The coefficient of a solenoid is

$$L = -\mu_0 n^2 l A$$

Check your progress: Answers

1. when a changing current flows through a conductor the changing magnetic flux surrounding the conductor should induce emf within it self ie in the conductor itself. This phenomenon is known as self induction.
2. Henry is the unit of inductance.

14.7 SAMPLE EXAMINATION QUESTIONS

I. Answer the following questions in detail

1. Derive the expression for the coefficients of self induction and mutual induction+

II Answer the following questions briefly.

1. Derive an equation for the Calculation of inductance of solenoid.

III Solve the following Problems

1. Find the self inductance per unit length of a long solenoid of radius 'R' carrying 'N' turns per unit length.
2. Find the self inductance of a toroidal coil of rectangular cross section, inner radius 'a', outer radius 'b' and height 'h', with 'n' turns.

UNIT 15: FARADAY'S LAW AND LENZ'S LAW

Contents

- 15.1 Objectives
- 15.2 Introduction
- 15.3 Electromagnetic Induction
- 15.4 Faraday's Laws of Induction
- 15.5 Lenz's Law
- 15.6 Expression for induced emf
- 15.7 Time varying magnetic field
- 15.8 Moving coil Galvanometer
- 15.9 Damping correction
- 15.10 Summary
- 15.11 Sample examination questions
- 15.12 Recommended books

15.1 OBJECTIVES

This unit discusses the concept of electromagnetic induction and Faraday's Laws of induction. To make you understand the concept the unit explains

- 1) Electromagnetic induction
- 2) Faraday's Laws
- 3) Mathematical equations for induced emf.

After going through this Unit you will be able to explain

- 1) What is meant by electromagnetic induction; and the principle under lying behind the working of a moving coil galvanometer.

15.2 INTRODUCTION

We have seen in the proceeding units that a current flowing through a wire produces magnetic field around its surroundings. It was observed and also investigated thoroughly by Michael Faraday in 1831 that changing magnetic lines of force through a closed loop of copper wire generated electromotive force. This electromotive force can be used as a source for production of electric power.

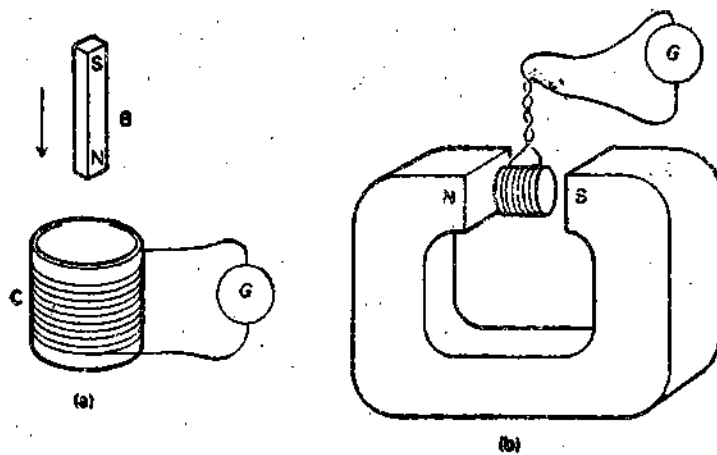

Fig 15.2 (a) Motion of a bar magnet B in a coil C.
 (b) Motion of the coil C between the pole pieces of a permanent magnet.

The current that appears in the experiments is called induced current and is said to be set by an induced electromotive force. Faraday as well as Lenz were able to deduce laws governing the behaviour of these induced emfs and induced currents

15.4 FARADAY'S LAWS OF ELECTRO MAGNETIC INDUCTION

The experimental evidence of electromagnetic induction has been summed up in the form of two laws, which are stated as follows.

These laws are known as Faraday's laws of Electro magnetic induction.

- (i) Whenever the magnetic flux is linked with a closed circuit changes in induced emf is set up in the circuit, whose magnet at any instant is proportional to the rate of change of magnetic flux linked with the circuit.

$$\text{i.e., } e = - \frac{d\phi}{dt}$$

(-ve sign because decrease-influx with induced emf)

ϕ = Magnetic flux linked with the circuit at any instant.

- (ii) The direction of induced emf is such that it opposes the change in flux that produces it.

This law is known as Lenz's law. Though the direction of induce emf was determined by Faraday's, but it was expressed as a law of lenz.

This law can be mathematically expressed as

$$\text{i.e., } e = - \frac{d\phi}{dt} \quad \dots(15.1)$$

in this e = induced emf, ϕ = instantaneous flux in Weber

To explain Faraday's laws of electro magnetic induction, we consider the coil and magnet in the experiment.

$$\int \vec{\nabla} \times \vec{E} \, ds = \frac{d}{dt} \int \vec{B} \cdot d\vec{s} \quad \dots (15.4)$$

$$\vec{\nabla} \times \vec{E} = -\frac{d\vec{B}}{dt} \quad \text{This equation is the integral form of Faraday's law.} \quad \dots (15.5)$$

15.5 LENZ'S LAW

We have seen that the Faraday's law is written as

$$\phi = -N \frac{d\phi_B}{dt} \quad \dots (15.6)$$

Where -ve sign indicates the direction on which the induced emf acts. This result could also be stated in terms of Lenz's law, stating the induced emf always acts in such a direction that it opposes the changes causing it. This is a consequence of the law of conservation of energy.

To predict the direction of the induced emf, let us consider a simple experiment of single turn coil (loop) and a bar magnet as shown in Fig. 15.5. Let the north pole of the

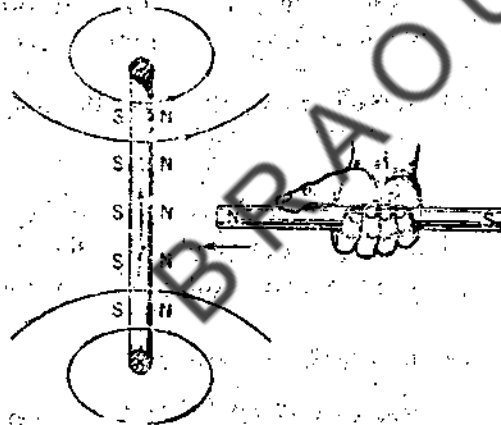

Fig 15.4 If the magnet with its north pole is moved toward the loop, the induced current develops as shown, setting up a magnetic field that opposes the movement of the magnet. magnet is facing the conducting loop. When the bar magnet is suddenly pushed towards the loop an induced voltage will be developed in the loop. This induced emf setup its own magnetic field around it and thereby behaves like a magnetic dipole, one face of the loop, being a north pole, the opposite face being a south pole. As usual the lines of B would emerge from the North Pole. According to Lenz's law, if the loop is to oppose the motion of the magnet towards it, the face of the loop towards the bar magnet must become a north pole. Thus the two north poles, one being of the conducting loop and the other is being of the bar magnet will repel each other. The right hand rule shows that the current will be counter clock-wise as we see along the magnet towards the loop.

To make the right hand face a south pole, the current must be opposite as shown in the Fig 15.5. Whether we pull or push the magnet its motion will always be automatically opposed.

By the left hand rule, this force is directed from Q to P. This will result in a flow of positive charge in the direction Q to P. The charge will be acted on by a force F over the length of wire l , in the magnetic field and it will consequently gain energy.

$$Fl = Bev l \quad \dots(15.8)$$

(Now precisely the same effect could have been produced in the circuit in the absence of any motion through the magnetic field by inserting a source of emf into the circuit. The magnitude of this emf would have to be equal to the product Bev to produce the same current as we now observe).

Thus the movement of the circuit through the magnetic field generates an emf in the conductor PQ of magnitude.

$$\therefore \varepsilon = \frac{Bevl}{e}$$

$$\therefore \varepsilon = Bvl \quad \dots(15.9)$$

Since the flow of positive charge is in the direction PSRQ the end P of the wire l will be the conventional positive end, while Q is negative. This induced emf sets up a current given by

$$i = \frac{\varepsilon}{R} = \frac{Bvl}{R} \quad \dots(15.10)$$

Where R is the resistance of the wire.

15.7. TIME VARYING MAGNETIC FIELD

It is also possible to have induced emfs without any physical motion of objects, i.e., magnet or the coil. However, the magnetic field should vary with time. If a conduction loop is placed in such a time varying magnetic field, the flux through the loop changes resulting in the creation of an induced emf in the loop.

Let us consider the following quantitative illustration of certain arrangement as given in the Fig 15.8 related to changing.

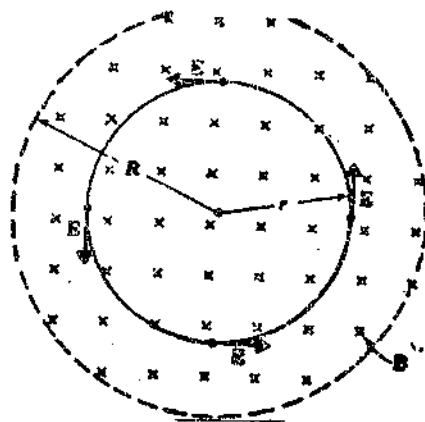

Fig 15.7 Time varying magnetic fields.

15.8 MOVING COIL GALVANOMETER

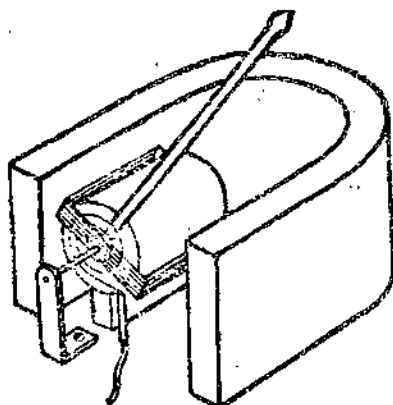

Fig 15.8 working model of a moving coil galvanometer.

It has been made use that the magnetic effect may be employed of measuring currents. The instruments in which the magnetic effect is used for measuring and detecting current or electric charge are called galvanometers. There are several types of galvanometers depending on the construction for a specific purpose. Thus, those in which a current carrying conductor moves when placed in a fixed permanent magnetic field, are called **moving coil galvanometers**. This is used to measure momentary currents.

A design formula can be derived for the moving coil galvanometer as follows.

A moving coil galvanometer consists of a flat coil of insulated wire which is suspended between the poles of permanent horse shoe type magnet. Usually the coil is suspended by a phosphor bronze wire. When a momentary current is passed through the coil, it produces its own magnetic field. There will be an interaction between this magnetic field and the field due to permanent magnet. Since the field provided by the permanent magnet is radial in the region where the coil is free to move. The plane of the coil is always parallel to the field. Hence the coil which deflected from its equilibrium or a torque is produced by the current. The kick or deflection indicated by the moving system is proportional to the strength of the momentary or steady current passing through it.

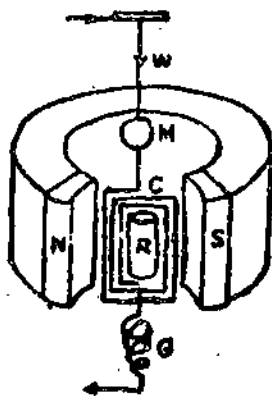

Fig 15.9 Moving coil galvanometer.

15.9 DAMPING CORRECTION

Galvanometers are used for quick measurement of steady currents. A moving coil galvanometer can either simply register the deflection without oscillating about its mean position (dead beat condition) or oscillate about its mean position (Ballistic condition). Under ballistic condition the vibrations are considered to be ideally simple harmonic. But in actual experiments, the amplitude of the swing progressively decreases due to several reasons such as air resistance. Thus the deflection is damped. Hence the observed deflection is less than what it would have been under ideal condition. Therefore a correction is to be added to the observed throw (Oscillation) to compensate the damping. The correction is called damping correction.

Experimentally, it is found that the ratio of any two consecutive deflections will be constant. It means that the rate of decrease of the deflection is constant.

Let $\phi_1 \phi_2 \phi_3 \phi_4 \dots$ etc are the recorded deflections on the left and right consecutively

$$\frac{\phi_1}{\phi_2} = \frac{\phi_2}{\phi_3} = \frac{\phi_3}{\phi_4} = d \quad \dots (15.18)$$

Where the ratio d is called decrement and $\log d = \lambda$ called logarithmic decrement

$$\text{Hence } e^{\lambda} = d \quad \dots (15.19)$$

Therefore Eqn. (15.18) can be written as

$$\frac{\phi_1}{\phi_2} = \frac{\phi_2}{\phi_3} = \frac{\phi_3}{\phi_4} = \dots = e^{\lambda} \quad \dots (15.20)$$

The deflections ϕ_1 and ϕ_2 are separated by half an oscillation, while ϕ_1 and ϕ_3 are separated by one complete oscillation

$$\frac{\phi_1}{\phi_3} = \frac{\phi_1}{\phi_2} \times \frac{\phi_2}{\phi_3} = e^{\lambda} \cdot e^{\lambda} = e^{2\lambda} \quad \dots (15.21)$$

Similarly ϕ_1 and ϕ_2 are separated by three and half oscillations and related by

$$\frac{\phi_1}{\phi_4} = \frac{\phi_1}{\phi_2} \cdot \frac{\phi_2}{\phi_3} \cdot \frac{\phi_3}{\phi_4} = e^{\lambda} \cdot e^{\lambda} \cdot e^{\lambda} = e^{3\lambda} \quad \dots (15.22)$$

If ϕ_0 is the undamped first throw which reaches its maximum ϕ_1 after one quarter of an oscillation, from the analogy of Eqn. (15.22) one can write

$$\therefore \frac{\phi_0}{\phi_1} = e^{1/2} \text{ or } \phi_0 = \phi_1 e^{1/2} \quad \dots (15.23)$$

or by expression

Hence the total induced emf is also zero.

Example -2:

A uniform field of induction **B** is normal to the plane of a circular ring 10 cm in diameter made of 0.1-inch diameter. At what rate **B** must change with time if an induced current of 10 Amps is to appear in the ring.

Solution:

$$\text{Radius of the copper wire} = 0.127 \times 10^{-2} \text{ m.}$$

$$\begin{aligned} \text{Resistance of the wire } R &= \frac{1.7 \times 10^{-8} \times \pi \times 10 \times 10^{-2}}{\pi \times (0.127)^2 \times 10^{-4}} \\ &= 105.4 \times 10^{-5} \text{ Ohm} \end{aligned}$$

$$\phi_B = BA = 78.54 \times 10^{-4} B$$

$$\varepsilon = \frac{d\phi_B}{dt} = 78.54 \times 10^{-4} \times \frac{dB}{dt}$$

$$i = 10 \text{ Amp; } \therefore \frac{\phi}{R} = 10 = \frac{78.54 \times 10^{-4}}{105.5 \times 10^{-5}} \frac{dB}{dt}$$

$$\frac{dB}{dt} = 134 \text{ Weber / m}^2\text{-s}$$

Example - 3:

The figure shows a copper rod moving with a velocity, **V** parallel to a long straight wire carrying a current, **i**. Calculate the induced emf in the rod, assuming that **V** = 5.0 m/s

Solution

$$i = 100 \text{ Amp, } a = 10 \text{ cm and } b = 20 \text{ cm}$$

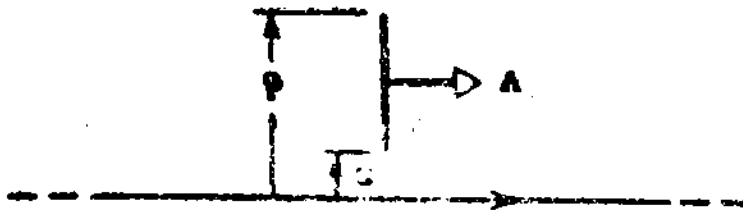

Fig 15.11

BRAOU

- (ii) The direction of induced emf is such that it opposes the change in flux that produces it.

$$e = - \frac{d\phi}{dt}$$

e = induced emf, ϕ = instantaneous flux is Weber.

- II
1. Generally the instrument in which magnetic effect is used for measuring an detecting current are electric charge are called galvanometers. But an instrument in which a current carrying conductor moves when placed in a fixed permanent magnetic field are called moving coil galvanometer. This is used to measure momentary currents.
 2. Sensitivity of a galvanometer can be defined as the angular deflection of the coil per unit currents.

$$\frac{\phi}{i} = \frac{B_n A}{k}$$

The sensitivity is large if B_n or A are made large and k is made small.

15.11 SAMPLE EXAMINATION QUESTIONS

I Answer the following questions in detail

1. Describe the Faraday's law of induction and Lenz's law to explain the induced emf in a circular loop.
2. Discuss and describe the working principle of a moving coil galvanometer. How the damping correction helps to get actual value of the currents being measured by the moving coil galvanometer?

II. Answer the following questions briefly.

1. Explain about the time varying magnetic field.
2. How do you explain the induced current voltage in a loop in the basis of law of conservation of energy?

III. Solve the following problems

1. A uniform field of induction B is changing in magnitude at a constant rate dB/dt . You are given a mass m of copper which is to be drawn into a wire of radius r and formed into a circular loop of radius R . Show that the induced current in the loop does not depend on the size of the wire of the loop and assuming B perpendicular to the loop is given by $i = \frac{m}{4\pi\rho\delta} \frac{dB}{dt}$ where P is the resistivity of the copper.

4. In Fig 15.13(c) a conducting rod A B makes contact with the metal rails A D and b C which are 50 cm apart in a uniform magnetic field of induction 1.0 Weber/m perpendicular to the plane of the paper as shown. The total resistance of the circuit ABCD is 0.4 ohm (assumed constant). (a) What is the magnitude and direction of the emf induced in the rod when it moved to the left with a velocity of 8 m/s? (b) What force is required to keep the rod in motion? (c) Compare the rate at which mechanical work is done by the force F with the rate of development of heat in the circuit.



Fig III (3)

15.12 RECOMMENDED BOOKS

- | | | | |
|---|--|--|--|
| 1 | Kraus, J.D. and Carver, K.R | Electromagnetics | Mc Graw-Mill K
Kogakusha, Ltd. Tokyo. |
| 2 | Corsan, D.R. and Lorrian. P | Introduction to
Electromagnetic
Fields and Waves | Freeman Toppa, London |
| 3 | Griffiths D. | Introduction to
Electrodynamics | Printice-Hall of India
New Delhi. |
| 4 | Plonsey. R. And Collin, R.E | Principles and
Applications of
Electromagnetic
Fields | Tata-Mc Graw Hill
Publishing Company Ltd.,
New Delhi |
| 5 | Laus' B.B | Electromagnetics | Willey Eastern Ltd.
New Delhi |
| 6 | Halliday, D and Resnick R | Physics-Part II | Wiley Eastern Ltd.
New Delhi |
| 7 | Grant. I.S. and Philips, W.R | Electromagnetism | John Wiley & Sons.
Chichester |
| 8 | Wenham, E.J. Dorling
G.W. Snell, J.A.N.
And Taylor. B. | Physics Concepts
and Models | Addison-Wesely
Publisher Ltd
London. |

Information regarding electric and magnetic fields was available to scientists about the middle of the nineteenth century. Indeed the very concept of existence of an electric or magnetic field a new idea of Faraday at that time, was considered with doubt by most scientists. Previously, fields had been looked upon as convenient means of visualizing the arrangement of force that resulted from electric and magnetic action. But to Faraday the magnetic field was the actual means by which magnetic force was exerted.

From the time of Ampere's work (1820 to 1825) it has been considered that one wire carrying current exerted a force on another wire carrying current and no intermediate agency for exerting force was taken into account. This was the action-at-a-distance theory, and it followed logically Newton's Universal law of Gravitation. Newton's Law assumed action at a distance, for it did not consider any medium necessary for the transmission of gravitational force. However, Faraday conceived the physical reality of electric and magnetic fields, and Maxwell undertook to express the mathematical relations involved.

16.3 ENERGY STORED IN A MAGNETIC FIELD

In a similar way, an inductor stores energy in its surroundings when the current is passing through it. This may be demonstrated with the help of the circuit shown in the Fig 16.1. When the switch S is closed the lamp glows. But, when the switch is opened the brightness of the lamp increases momentarily. This increase in its brightness is due to the magnetic. Energy stored in the magnetic field of the induction, as the magnetic field of the inductor induces a large current momentarily when the field collapses.



Fig 16.1 Circuit for demonstrating energy stored in a magnetic field.

To calculate the work in establishing the magnetic field, We shall calculate the energy supplied by a source to an isolated circuit (Fig 16.2) when the current increases from zero to some value. The circuit shown in the figure 16.2 consists of R the resistance, inductive coil with self-inductance L and E and emf of the battery.

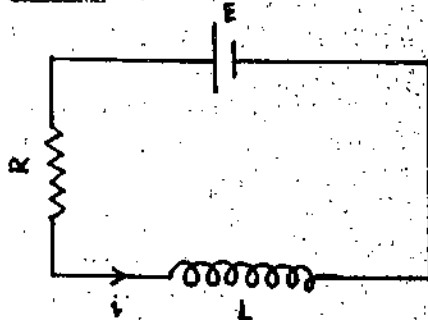

Fig 16.2

Consider a solenoid consisting of length l and cross sectional area A . Then lA is the volume associated with the length of the solenoid.

$$\therefore \text{The magnetic field energy density } v_B = \frac{U}{lA}$$

$$\text{Since } U_B = \frac{1}{2} Li^2$$

$$U_B = \frac{\frac{1}{2} Li^2}{lA} \quad \dots(16.6)$$

But the coefficient of inductance of a solenoid is $\mu_0 n^2 lA$ and the magnetic induction

$$B = \mu_0 ni$$

Substituting l and i values in the equation

$$\text{We get } U_B = \frac{1}{2} \frac{B^2}{\mu_0} \quad \dots(16.7)$$

Though this magnetic field density equation is derived for the special case of a solenoid, the formula of equation 16.7 holds good for all magnetic fields.

16.5 PRINCIPLE OF A TRANSFORMER

A transformer is an electrical device by which a low alternating voltage can be converted into a high alternating voltage, however the initial current gets reduced proportionately or vice versa with the increase in voltage. The same device can also be employed for converting high voltages to low voltages.

The transformer consists of two coils wound on a common core. The core is made of high permeability material such as soft iron. The function of this core is to increase the magnetic flux linking the coil, hence increasing the mutual inductance between each pair of them. The coil P connected to the voltage to be changed is called the primary and the other coil S between the ends of which the alternate voltage is obtained is called secondary. The core carrying the coils P and S are usually made up of thin layers of magnetic materials, also known as laminations, which are electrically insulated from each other by layers of laminating paper. The figure 16.3 shows a cross sectional view of a transformer and conventional circuit symbol for a transformer.

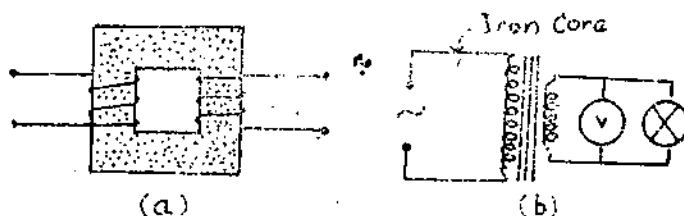

Fig 16.3 (a) (b)

16.3a a model transformer

16.3b - Transformer in a circuit

When an alternating voltage is applied across the ends of the primary coils, it causes a varying magnetic flux in the core. By Faraday's law of induction an alternating induced

power losses are eddy currents, hysteresis and magnetic leakage. In large transformers, which are widely used, the efficiency is 98% whereas in small transformers it is about 90%.

Example:

1. A coil with an inductance 2 henrys and a resistance of 10 ohms is suddenly connected to a resistance less battery of 100 volts. (a) what is the equilibrium current (b) How much energy is stored in the magnetic field when this current exists in the coil ?

$$(a) \quad \frac{E}{R} = \frac{100}{10} = 10 \text{ amps (equilibrium current)}$$

$$(b) \text{ Stored energy} = \frac{1}{2} Li^2$$

$$= \frac{1}{2} \times 2 \times 10^2$$

$$= 100 \text{ joules}$$

2. A circular loop of wire 5 cm in radius carries a current of 100 amps what is the energy density

$$vB = \frac{1}{2} \frac{B^2}{\mu_0} \text{ and } B = \frac{\mu_0 i}{2R}$$

$$vB = \frac{1}{2} \frac{\mu_0^2 i^2}{4R^2}$$

$$= \frac{1.26 \times 10^{-6} \times (100)^2 \times 10^{-4}}{8 \times 5 \times 5}$$

$$= 0.63 \text{ Joule / m}^3$$

3. An ideal transformer has a turns ratio of 2, i.e, $N_2/N_1 = 2$ An ac emf of 10 V is applied to the primary. Find the emf or voltage appearing in the secondary terminals.

$$\varepsilon_2 = \frac{N_2}{N_1} \varepsilon_1$$

$$= 2 \times 10 = 20 \text{ V}$$

16.6 MAXWELL'S EQUATIONS

These equations are based on the several crucial experimental results obtained as mentioned below:

- (a) An electric field is found to exist and is defined.
- (b) Divergence of electrostatic field is proportional to charge density.
- (c) A magnetic field is found to exist and is defined. But it is impossible to create an isolated magnetic pole.

Once again, the physical meaning of these equations can be inferred as follows:

Equation 16.18 says that a changing electric field will produce a magnetic field and equation 16.19 says that a changing magnetic field will produce an electric field. These equations are particularly interesting to consider relative to the propagation of electric waves. It will be seen at once that, if a changing electric field produces a magnetic field and that in turns produces an electric field which produces a magnetic field and so on, some kind of series of energy transfers is started whenever any electric or magnetic disturbance takes place. While propagating energy will be transformed form the electric to the magnetic and back to the electric and so on indefinitely (this illustrated by figures 16.4 & 16.5).

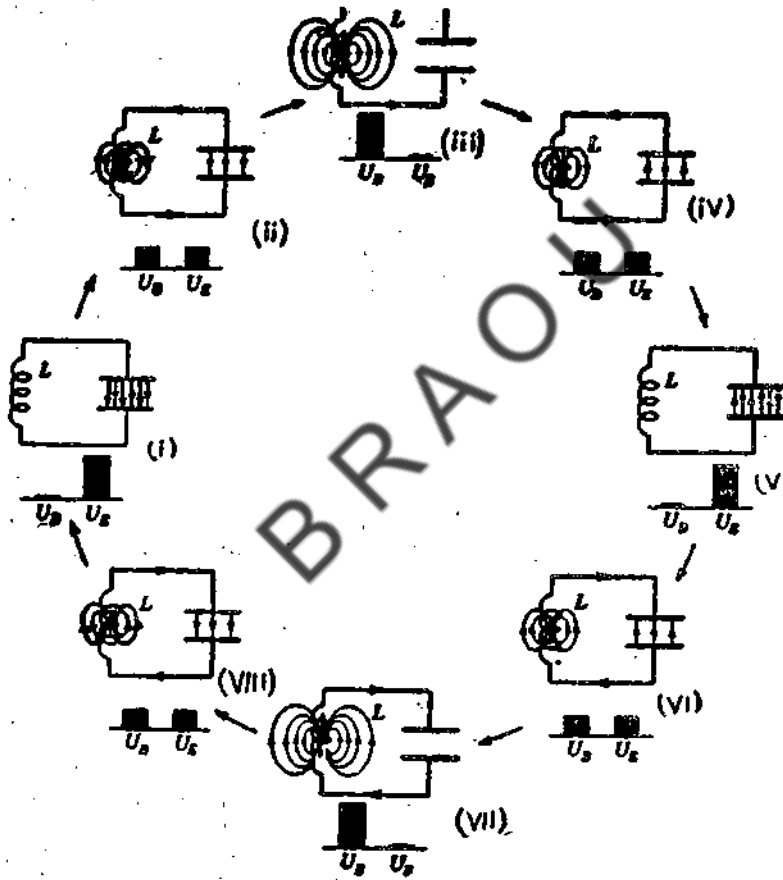

Fig 16.4

If (as is actually true) the magnetic energy is not confined to precisely the same location in space as the electric energy from which it is derived, but extends a little beyond, and, if the electric energy derived from that magnetic energy is again a little farther advanced in space, and so on, so that the energy is changing form to form and is also being propagated through space, the result may quite reasonably be a traveling wave of electromagnetic energy. To understand this more clearly an analogous situation as described below:

16.7 THE POYNTING VECTOR

A very important aspect of wave propagation is the flow of energy through space. As the wave passes through a surface in space the energy get transported too. At any instant there will be a flow of power (watt / meter²) through each unit area of the surface and is

denoted by the symbol \vec{P} . The product $\vec{P} \cdot \vec{A}$ is the power passing through in area. A . Thus The rate of energy flow per unit are in an electromagnetic wave can be described by a vector \vec{P} , known as the Poynting vector after John Henry Poynting who first pointed out its properties. When flux line (vector \vec{P}) are drawn they show the flow of electromagnetic energy.

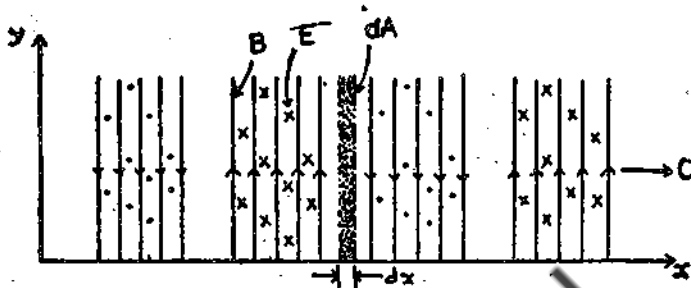

Fig. 16.6

Consider a region of space, enclosed within an imaginary surface. The rate at which electromagnetic energy flows out of this region is found by integration \vec{P} over the enclosed surface. The outward flow of power = $\oint \vec{P} \cdot d\vec{A}$. But, if the energy is flowing out of the region, there must be a corresponding loss of electromagnetic energy stored within that region. This is the sum of electric and magnetic energies given by the volume integrals:

$$\text{Electric energy} = \frac{1}{2} \int \vec{D} \cdot \vec{E} \, dv \quad \dots (16.22)$$

$$\text{Magnetic energy} = \frac{1}{2} \int \vec{B} \cdot \vec{H} \, dv \quad \dots (16.23)$$

$$\text{Total energy} = \frac{1}{2} \int (\vec{B} \cdot \vec{H} + \vec{D} \cdot \vec{E}) \, dv \quad \dots (16.24)$$

The rate at which this stored energy diminishes is obtained by differentiation i.e., the rate of decrease of

$$\text{Stored energy} = \frac{d}{dt} \frac{1}{2} \int (\vec{B} \cdot \vec{H} + \vec{D} \cdot \vec{E}) \, dv \quad \dots (16.25)$$

Assuming that there is no loss of energy by other means, we have

$$\oint \vec{P} \cdot d\vec{A} = - \frac{1}{2} \frac{d}{dt} \int (\vec{B} \cdot \vec{H} + \vec{D} \cdot \vec{E}) \, dv$$

As a simple example of the Poynting vector field, consider a long cylindrical conductor carrying current. As shown in figure 16.7 a steady current is flowing upward in a cylindrical conductor, the front half of the conductor being cut away in the diagram. The electric field with the conductor is correspondingly uniform and upward. The electric field outside the conductor is much stronger, having a tangential component that terminates on some other part of the circuit. The magnetic field within the conductor is circular, and its strength is proportional to the radius.

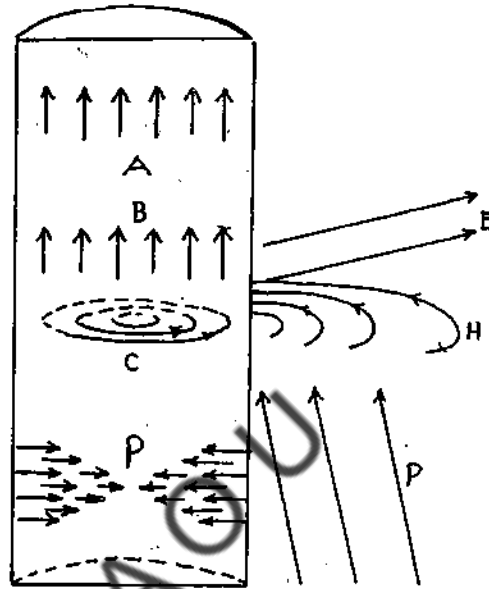

Fig 16.7

A - Current, B - Electric field, C - Magnetic Field, P - Poynting Field.

The Poynting field within the conductor, being $\vec{E} \times \vec{H}$, is radially inward, growing weaker as it penetrates the conductor.

The increasing weakness of the pointing field indicates the consumption of energy. Energy enters the surface of the conductor and flows towards the center. This is used to supply resistance loss in the conductor and the inward flow of energy decreases to zero, as the center of the conductor is approached. The Poynting field outside the conductor is primarily parallel to the conductor, showing that the energy is being carried in the direction of the conductor (which serves as a guide for energy). But the external field has a sufficient radial component to give an inward flow of energy to provide for the loss of energy in the conductor. Only around a conductor of perfect conductivity would the pointing field be wholly parallel to the conductor.

Note particularly the Poynting vector and therefore the direction of travel of a wave. If the fingers of the right hand curve from \vec{E} to \vec{H} , the thumb shows the direction of travel of the wave. This very important relation is easily remembered if $\vec{E} \times \vec{H}$ is firmly impressed on the mind. Obviously a reversal of the order (i.e. $\vec{H} \times \vec{E}$) of these vectors would be ruinous, but the memory can be helped by noting that E precedes H as in the alphabet.

$$\nabla \times \vec{E} = - \frac{\partial \vec{B}}{\partial t} \quad (2)$$

$$\nabla \times \vec{E} = 0 \quad (3)$$

$$\nabla \times \vec{B} = 0 \quad (4)$$

The electric and magnetic field in the magnetic equation vectors represent the wave amplitudes traveling with the finite velocity in space these waves do not require a medium. These waves are transverse in character and they transport energy from one place to other place. Poynting vector represents the energy flow.

Check your progress :Answers

1. A Transformer is an electrical device by which a low alternating voltage can be converted into a high alternating voltage and vice versa.
The efficiency of a large transformer is 98% where as the efficiency of a small transformer is only about 90%.

2. Maxwell's equations of electromagnetic induction are

$$(i) \quad \nabla \times \vec{H} = \vec{j} + \frac{\partial \vec{D}}{\partial t}$$

$$(ii) \quad \nabla \times \vec{E} = 0$$

$$(iii) \quad \nabla \times \vec{E} = - \frac{\partial \vec{B}}{\partial t}$$

$$(iv) \quad \nabla \times \vec{B} = 0$$

16.9 SAMPLE EXAMINATION QUESTION

I Answer the following question in detail.

1. Discuss in detail the principle of a transformer.
2. Discuss about the construction and working of electromagnetic cavity oscillator.
3. show that electric and magnetic field vectors represent the wave amplitude, traveling with finite velocity in space.

II. Answer the following question briefly.

1. Obtain the expression for the energy in a magnetic field.
2. What is Maxwell's equation?
3. What is pointing vector.
4. What are traveling waves.

UNIT 17: - LR AND CR CIRCUITS

Contents

- 17.1 Objectives
- 17.2 Introduction
- 17.3 Simple A.C generator
- 17.4 Graphical representation of alternating emf and currents
- 17.5 Effective or RMS value of an AC current
- 17.6 Power factor of an AC Circuit
- 17.7 Energy stored in a LR Circuit
- 17.8 Resistance and capacitance in series AC Circuit
- 17.9 L.C Circuit
- 17.10 Summary
- 17.11 Sample Examination questions

17.1 OBJECTIVES

This Unit discusses the passage of electricity through electrical elements. In order to make you understand the effects of current passed through different combinations of electrical elements are set forth.

After going through this unit you should be able to understand the principle of operation of the alternating current generator; and the relation between the instantaneous and the effective values of current and emf for different combinations of electrical elements.

17.2 INTRODUCTION

In this unit the principle of operation of the alternating current generator is discussed also you will know about the alternating currents. You will be knowing about the power factor and energy stored in a LR circuit.

Also, at any time 't' the orientation θ of the coil is given by

$$\theta = \omega t + \delta \quad \dots(17.5)$$

Where δ represents the value of θ at $t = 0$. When equations 17.4 and 17.5 are substituted into equation 17.3, the expression for an instantaneous value of emf induced in the rotating loop becomes.

$$E = E_{\max} \sin (\omega t + \delta) \quad \dots(17.6)$$

Thus as asserted above, the induced emf behaves like harmonic oscillator.

17.4 GRAPHICAL REPRESENTATION OF ALTERNATING EMF AND CURRENTS

Equation 17.6 is represented by figure 17.2 as a solid curve with E as the ordinate and ωt as the abscissa.

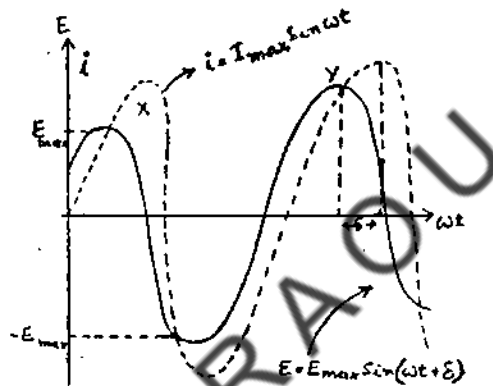

Fig. 17.2 Graphical representation of alternating EMF and currents.

As shown by the solid curve in figure 17.2 the instantaneous emf varies between the limits \pm where E_{\max} is known as the amplitude of the emf. The quantity appearing in equation 17.6 is the initial phase angle; thus the initial value of E (that is at $t = 0$) is given by $E_{\max} \sin \delta$. The phase of E at any subsequent time is determined by the instantaneous phase angle, $\omega t + \delta$; one complete alternation of emf is called one cycle and is accomplished in a time known as one period T.

When AC emf of the type described by equation 17.6 drives the current in circuit, the resulting current is also harmonic although not necessarily in phase with the emf. Let us suppose that the initial conditions and circuit parameters are such that the instantaneous current and emf may be written as

$$i = I_{\max} \sin (\omega t + \delta_1) \quad \dots(17.7)$$

$$E = E_{\max} \sin (\omega t + \delta_2) \quad \dots(17.8)$$

Where δ_1 and δ_2 are the initial phases. The emf reaches maximum at an earlier time than does the current, then the emf is said to lead the current by the phase angle.

We can evaluate equation 17.15 viz.,

$$\bar{i}^2 = \frac{I_{\max}^2}{2T} \int_0^T \left(\frac{\sin 2\omega t}{2\omega} \right)^2 dt = \frac{I_{\max}^2}{2T} \dots (17.17)$$

or $\bar{i}^2 = \frac{I_{\max}^2}{2}$

$$\text{Thus } I_{\text{eff}} = \sqrt{\bar{i}^2} = \frac{I_{\max}}{\sqrt{2}} = 0.707 I_{\max} \dots (17.18)$$

Where the effective value of AC current is 0.707 times the amplitude or its maximum value. Following the same arguments as given above, we have

$$E_{\text{rms}} = 0.707 E_{\max} \dots (17.19)$$

AC measuring instruments like ammeters and voltmeters, unless it is specifically stated to the contrary, read effective or rms values. As a result, effective values are ones normally dealt with

Example 1:

The equation for an alternating current is $i = 42.42 \sin 314 t$. Determine (i) its maximum value (ii) its frequency (iii) its RMS value.

We know

$$i = I_{\max} \sin \omega t$$

(a) $I_{\max} = 42.42$

(b) $\omega t = 314t$

$$\omega = 314$$

Now $\omega = 2\pi f$

$$f = 314/2\pi = 50\text{Hz}$$

(c) $I_{\text{rms}} = I_{\max} / \sqrt{2}$

$$= 42.42 / \sqrt{2} = 30 \text{ Amperes}$$

17.6 POWER FACTOR OF AN AC CIRCUIT

At any instant the rate of energy consumed in a circuit is given by the product of the current through it and the potential difference across it

$$\text{Instantaneous power dissipation} = i\bar{V} \quad \dots(17.20)$$

$$\text{Average power dissipation} = i\bar{V} \quad \dots(17.21)$$

$$\begin{aligned} &= \frac{1}{T} \int_0^T i v dt \\ &= \frac{1}{T} \int_0^T I_{\max} \sin \omega t V_{\max} \sin (\omega t + \delta) dt \\ &= \frac{I_{\max}}{T} V_{\max} \int_0^T \sin \omega t (\sin \omega t \cos \delta + \cos \omega t \sin \delta) \\ &= \frac{I_{\max} V_{\max}}{T} \int_0^T \left(\frac{1 - \cos 2\omega t}{2} \right) \cos \delta + \sin \omega t \cos \omega t \sin \delta \, dt \\ &= \frac{I_{\max} V_{\max}}{T} \left[\frac{t}{2} \cos \delta - \frac{\sin^2 \omega t \cos \delta}{4\omega} + \frac{\sin^2 \omega t \sin \delta}{2} \right]_0^T \\ &= \frac{I_{\max} V_{\max}}{2} \cos \delta \\ &= IV \cos \delta \quad \dots(17.22) \end{aligned}$$

$\cos \delta$, which appears in equation 17.22 is known as the POWER FACTOR. For purely resistive circuits, in which $\delta = 0$, the power factor is unity and the power is given by the product of the effective current and the effective voltage.

17.7 ENERGY STORED IN A LR CIRCUIT

Consider a circuit containing a pure inductive coil of inductance L Henry and pure resistance of R ohm connected in series as shown in Fig 17.3

Thus the relation shown in equation 17.23 can be written as ... (17.24)

$$i = V / Z$$

or $V = iZ$... (17.25)

A triangle whose sides are proportional to the voltage V , V_L and V_R is called voltage triangle. A triangle whose sides are proportional to R , X_L and Z is called impedance triangle Fig. 17.5

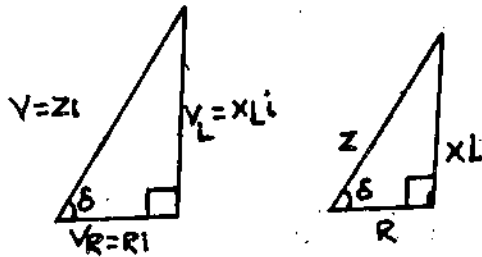

Fig 17.5 Impedance triangle

It is clear that the vector V leads the vector the 'i' by an angle. The cosine of this angle i.e. $\cos \delta$ is called the power factor.

Power factor = $\cos \delta = R / Z$... (17.26)

Assuming voltage leads current by an angle δ the current and voltage can be shown as

$$V = V_{\max} \sin \omega t$$

$$i = I_{\max} \sin (\omega t - \delta)$$

We know that power is equal to the product of current and voltage

$$P = Vi$$

$$= V_{\max} \sin \omega t I_{\max} \sin (\omega t - \delta)$$

$$= V_{\max} I_{\max} \sin \omega t \sin (\omega t - \delta)$$

$$= \frac{1}{2} V_{\max} I_{\max} [\cos (2\omega t - \delta)]$$

Now the value of $\cos \delta$ is constant in a given circuit where as $\cos (2\omega t - \delta)$ is a variable quantity and its value is zero. Thus the average power.

$$P_{av} = \frac{1}{2} V_{\max} I_{\max} \cos \delta$$

$$= \frac{V_{\max}}{\sqrt{2}} \times \frac{I_{\max}}{\sqrt{2}} \cdot \cos \delta \quad \dots (17.27)$$

In series same voltage but opposite, in parallel the same current but opposite.

Thus at resonant frequency & when $R=0$, the line current would be zero but there is an oscillatory current in L & C. The applied emf merely supplies the energy to compensate for any circuit losses

One finds that, for fixed values of L, C & R, the impedance of an L, C & R circuit depends on $(\omega = 2\pi f)$. Hence it varies with frequency. In such a circuit, $W_L = I \omega L$ or $2\pi f L$. $W_C = 1 / 2\pi f C$ i.e. If the inductive reactance = capacitive reactance, or at a particular frequency of AC, f is such that

$$f^2 = \frac{1}{4\pi^2 LC} \quad \text{or } f = \frac{1}{2\pi\sqrt{LC}} \quad \dots(17.30)$$

Then in equation $Z = \sqrt{R^2 + (\omega L + 1/\omega C)^2}$

Maximum current will be admitted through the circuit and the circuit will behave as if the coil and condenser were absent. The circuit is said to be in time or Resonance with applied emf (i.e. the value of the frequency of applied emf) for which $W_L = 1/\omega C$, is called resonant frequency (f_0) and is given as so many cycles /sec. When L is in henries & C is in Farads. This gives condition for Resonance.

In a circuit like this

$$L \frac{di}{dt} + \frac{q}{C} = 0 \quad \dots(17.31(a))$$

$$\& \frac{di}{dt} + \frac{q}{CL} = 0 \quad \dots(17.31(b))$$

$$\& \frac{d^2i}{dt^2} + K^2 q = 0 \quad \dots(17.31(c))$$

$$\& W^2 = K^2, W = K = \frac{1}{\sqrt{LC}} \quad \dots(17.31(d))$$

$$\text{or } 2\pi f = \frac{1}{\sqrt{LC}} \quad f = \frac{1}{2\pi\sqrt{LC}}$$

Which is the same as equ. 17.30 above. This is the frequency of the oscillatory discharge in a circuit of inductance L and capacitance C when the resistance is low.

Thus the strength of AC in any series circuit due to a given applied emf is greatest when the frequency of applied emf is equal to the natural frequency of the circuit, a

condition analogous to that necessary for resonance in the case of sound. The above circuit is then called a series resonance circuit with R, &

$$f_0 = \frac{1}{2\pi\sqrt{LC}} \quad \dots(17.32)$$

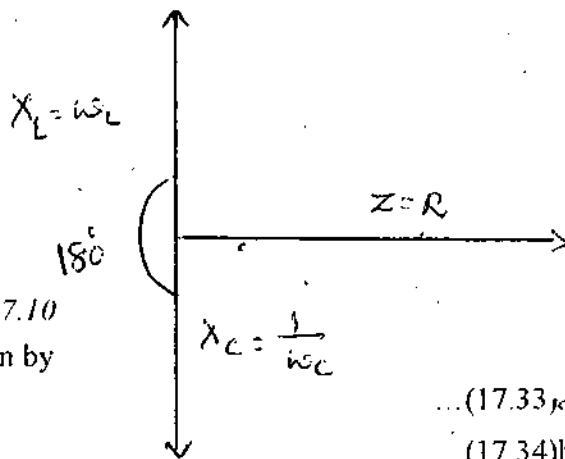

Fig 17.10

the maximum current in the circuit is given by

$$I_0 = E_0 / R \quad \dots(17.33a)$$

$$\& E_{rms} = I_{rms} R \quad \dots(17.34b)$$

Also at resonance the alternating P.D the inductance (L) & the capacity (c) are equal & 180° out of phase, or in antiphase

Thus the ratio of the voltage across (across the condenser) to the voltage across resistance or applied voltage at resonance is called the Q or voltage magnification factor of the circuit also the voltage across inductance or (capacitance)

$$= \frac{W L I_{rms}}{R I_{rms}}$$

Voltage magnification or factor

$$= \frac{W L I_{rms}}{R I_{rms}} = \frac{W L}{R}$$

If the frequency of a C supply is varied or it contains a no. of frequency components (as in a receiving serial) a series LCR circuit across its supply will or accept a maximum current. i.e. a maximum response for only that component of a supply which has a frequency

$$f = \frac{1}{2\pi\sqrt{LC}} \quad \dots(17.37)$$

provided the resistance R is very low or negligible.

It is also some times called an acceptor circuit. It is used as a tuning circuit with the arial of a radio receiving station. Also when R = 0, the impedance of the circuit becomes zero at the resonant frequency i.e. in LC circuit in other words.

Check your progress- II

1. Define Power factor
2. What is resonance frequency?
3. If R = 0, what happens to the impedance in L C circuit!

Note: a. Space is given below for your answers.

b. Compare your answers with those given at the end of the unit.

UNIT-18: TRANSIENT RESPONSE IN CIRCUITS

Contents

- 18.1 Objectives
- 18.2 Introduction
- 18.3 Resistors
- 18.3.1 Inductance
- 18.3.2 Inductance
- 18.3.3 Capacitance
- 18.4 Growth and Decay of the Current in LR Circuits
- 18.5 Growth and decay of current in CR Circuits
- 18.6 Transient behavior of series LCR circuit
- 18.7 Summary
- 18.8 Sample examination questions

18.1 OBJECTIVES

This Unit discusses the phenomenon of growth and decay of current in LR, CR and LCR series circuits.

To make you understand the phenomenon, circuits containing inductances and capacitances are explained.

After going through this Unit you should be able to evaluate the growth and decay of current in LR, CR and LCR circuits

18.2 INTRODUCTION

In this Unit we will discuss the currents in a LR circuit and charges in a CR Circuit.

Here in this Chapter we will also discuss about the transient behaviour of LR, CR and series LCR circuits. LCR series behaviour is analogous to that of a damped mechanical oscillator. The behaviour is analogous to what happens in a simple pendulum if it is displaced from its equilibrium position and then released. Depending on the amount of friction, or damping, the pendulum will either oscillate back and forth, with a gradually decreasing amplitude, or will move towards its equilibrium position without oscillations. We discuss the electrical analogue shown in Fig 18.1

The result is just the Ohms law which works equally well for both ac and steady voltages. The nomenclature for R can be generalized as resistive impedance.

18.3.2 Inductance

Fig 18.2 shows a simple inductance connected to a source of sinusoidal EMF and the coil is assumed to be of pure inductive nature.

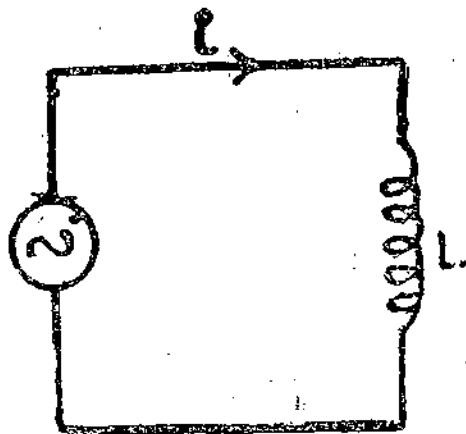

Fig 18.2 Inductance connected AC circuit.

As per the circuit equation we know that

$$E + E_L = 0$$

Where E_L is induced voltage across the inductance coil. The induced EMF E_L is thus

$$E_L(t) = -L \left(\frac{di}{dt} \right) \quad \dots (18.5)$$

Where L is the self inductance of the coil. The negative sign denotes the effect of E_L in the circuit which tends to decrease the magnitude of current.

Combining the last two equations we get

$$E = V(t) = V_0 \cos \omega t \quad \dots (18.6)$$

Since $E_L = -E$

$$L \left(\frac{di}{dt} \right) = V_0 \cos \omega t \quad \dots (18.6(a))$$

The interpretation of the $i(t)$ is such that the slope (di/dt) is also a varying function of time having the same phase as the generating voltage and amplitude is given by V_0/L . An expression for the current $i(t)$ can be obtained by integrating the expression.

$$i(t) = \frac{V_0}{\omega L} \sin \omega t$$

$$= \frac{V_0}{\omega L} \cos(\omega t - \pi/2) \quad \dots(18.9)$$

Equation 18.8 manifests that the quantity (ωL) plays same role as does R in resistive case and ωL is known as the inductive reactance.

18.3.3 Capacitance

The instantaneous voltage V across a capacitor 'C' is shown in Fig 18.4

$$V(t) = \frac{q(t)}{C} \quad \dots(18.10)$$

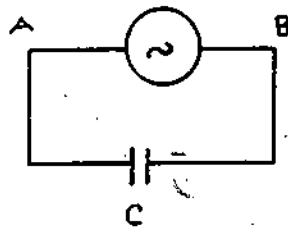

Fig. 18.4 Circuit consisting of a capacitor connected to a AC source

The circuit equations for this case has to be modified to accommodate the voltage across the capacitor, caused by the charge q on it at any instant of time. Choosing zero time when the voltage at A caused by the generator is positive and say, increasing the charge on the capacitor starting from an instant when its charge was zero, is

$$q(t) = \int_0^t i \cdot dt \quad \dots(18.11)$$

The situation at time t is described by the circuit equation, i.e.

$$v(t) = + E(t) = 0 \quad \dots(18.12)$$

In order to express this result in terms of $i(t)$, since $i = dq / dt$ we differentiate equation 18.12 to find

$$\omega C V_0 \sin \omega t dt = dq$$

$$\text{or } -\omega C V_0 \sin \omega t = dq / dt = i(t) \quad \dots(18.13)$$

We can now write the current as $I_0 \sin \omega t$ with I_0 being equal to $C \omega V_0$

where $e^{j\theta} = \cos \theta + j \sin \theta$... (18.16)

Where N is a real number, called the modules, and θ an angle, in radians. Together N and θ describe the magnitude and direction of a vector in the complex plane, as shown in Fig. 18.6 (e is the base of the natural logarithms). This result depends on the identity shown in appendix II.

The particular advantage of complex numbers in a circuit is that they provide a two dimensional name with appropriate vectors arising in the a.c. circuit analysis. In particular let the angle θ be a function of time using $\theta = \omega t$. then equation (18.16) becomes.

$$e^{j\omega t} = \cos \omega t + j \sin \omega t \quad \dots (18.17)$$

$e^{j\omega t}$ now represents a unit vector rotating with constant angular velocity ω , and is thus suited for representing any rotating vector in an ac circuit. The two terms $\cos \omega t$ and $j \sin \omega t$ give the real and imaginary components of the rotating vector. Either one can be used to represent a sinusoidal functions of time.

Resistor

We replace sinusoidal voltage $E(t) = V_0 \cos \omega t$ by the expression

$$E(t) = V_0 e^{j\omega t} \quad \dots (18.18)$$

This gives the vector amplitude V_0 rotating at an angular frequency ω . As per the eqn. 18.17 one can get either cosine or sine function of the time variation of voltage. The circuit equation now gives

$$i(t) R = V_0 e^{j\omega t} = V_0 [\cos \omega t + j \sin \omega t]$$

$$i(t) = [V_0/R] e^{j\omega t} = V_0/R [\cos \omega t + j \sin \omega t] \quad \dots (18.19)$$

The ac resistive impedance of the resistance is the real number R .

Inductor

From equation 18.6a the generator voltage in a complex numbers notation is given by

$$\frac{di}{dt} = \frac{V_0}{L} e^{j\omega t} \quad \dots (18.20)$$

This may be written in integral form

$$di = \frac{V_0}{L} e^{j\omega t} dt \quad \dots (18.21)$$

Which immediately integrates to

$$X_c = \frac{1}{j\omega C} = -j/\omega C \quad \dots(18.27)$$

In this case ac current vector, according to eqn. 18.26 is real number $j\omega V_0$ multiplied by j . As shown in Fig 18.8 this rotates the current vector 90° , ahead of the voltage to lead it by 90°

To summarize the current amplitude

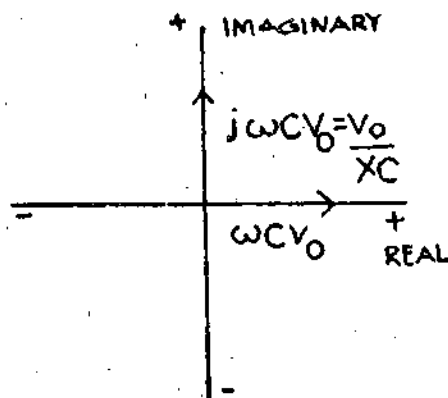

Fig 18.8

each kind of element R, L and C can be written in terms of the ac impedance Z, using the equation.

$$I_0 = \frac{V_0}{Z} \quad \dots(18.28)$$

Where $Z_R = R$ resistive impedance I_0 in phase with V_0

$Z_L = j\omega L = X_L$ inductive resistance I_0 lags V_0 by 90°

$Z_C = \frac{1}{j\omega C} = X_C$ capacitive resistance I_0 leads V_0 by 90°

All three terms may contribute to the total ac impedance of a current in general.

18.4 GROWTH AND DECAY OF THE CURRENT IN LR CIRCUITS

In circuit where the energy can be stored as in a charged capacitor or in an inductance while it is carrying current, the sudden application or removal of an applied voltage causes a momentary changing response in the circuit while it adjusts to the new conditions. Here in this we discuss few cases.

To begin with we discuss the case of an inductor and a resistance in series to which a voltage source is connected with a closing and opening switch.

$$1 - \frac{R di}{V - Ri} = - \frac{R}{L} dt$$

(Where we have multiplied both sides by $-R$ to make left-hand side a perfect differential and integrating we get

$$\log(V - Ri) = \frac{Ri}{L} + C \quad \dots(18.31)$$

Where the integration constant C can be evaluated from the condition that at $t=0$, (when the switch is closed) $i=0$. This gives $C = \log V$. We put this in above equation and convert it to be exponential form

$$V - Ri = V e^{-Ri/L} \quad \dots(18.32)$$

The current is given by

$$\begin{aligned} i &= \frac{V}{R} [1 - e^{-Ri/L}] \\ &= I_0 (1 - e^{-Ri/L}) \end{aligned} \quad \dots(18.33)$$

A plot of this solution is given in Fig 18.11. The behaviour of the circuit is completely determined by the value of R/L , or by its reciprocal $L/R = \tau$, the relaxation time of the circuit, with the use of τ as defined the equation becomes

$$i = I_0 (1 - e^{-t/\tau}) \quad \dots(18.34)$$

τ is the time for the current to build up to $[1 - \frac{1}{e}]$ or 0.632 of

its final value. We see this by putting $t = \tau = \frac{L}{R}$

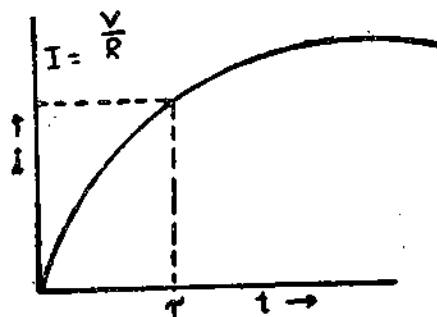

Fig 18.11

$$i = I_0 (1 - \frac{1}{e}) = I_0 (1 - 0.318) = 0.632 I_0 \quad \dots(18.35)$$

There are many physical situations which lead to equations like $V = Ri + L (di/dt)$ and hence to solutions of the form of equation (18.33). These can be identified as giving rise to an exponential approach of variable to a final value. When this identification can be

This removes battery from the circuit, while allowing the current to flow until decays exponentially to zero. Letting $t = 0$ at the moment the switch is changed, the equation describing the circuit becomes.

$$0 = Ri - L \frac{di}{dt} \text{ (because of } \frac{di}{dt} \text{ -ve)} \quad \dots(18.39)$$

This problem could be solved by separation of variables; but instead we go directly to the solution by applying the boundary condition of the problem to an assumed exponential solution. In this case at $t = 0$, $V - Ri = I_0$ since there is no voltage drop across the inductance when the current is steady. Also after a long time the current will go to zero. So the obvious solution to equation 18.39 is of the form

$$I(t) = I_0 e^{-t/\tau} = \frac{V}{R} e^{-t/\tau} \quad \dots(18.40)$$

it is easy to verify that τ has the same value L/R . A plot of the current against time is shown in Fig 18.13. Here τ is the decay of current in RL circuit after the voltage source is removed, time for the current to fall to the fraction $1/e$ of its original steady state.

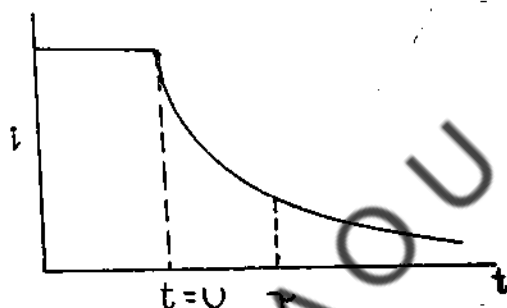

Fig 18.13

18.5 GROWTH AND DECAY OF CURRENT IN CR CIRCUITS

The RC circuit is shown in Fig 18.14

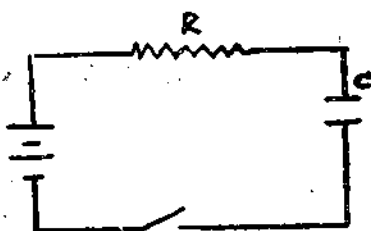

Fig 18.14

The equation that applies when the switch is closed is

$$V_0 = R \frac{dq}{dt} + \frac{q}{C} \quad \dots(18.41)$$

Finally, we study the case of the discharge of the capacitor as shown in Fig 18.16. We start with the capacitor charged to a potential $V_0 = Q_0/C$ when the switch is closed, the situation is described by

$$\frac{Q}{C} + R \cdot \frac{dq}{dt} = 0$$

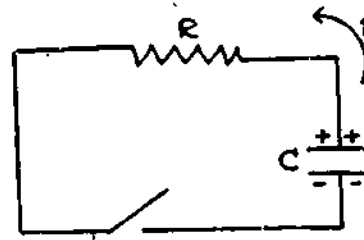

Fig. 18.16 18.16

Fig 18.16

The solution of the above equation

$$q = Q_0 e^{-t/RC} \quad \dots (18.47)$$

$$i = -\frac{dq}{dt} = \frac{Q_0}{RC} e^{-t/RC} = \frac{V_0}{R} e^{-t/\tau} \quad \dots (18.48)$$

This result is identical with equation 18.40. However, the current is flowing in a direction to discharge the capacitor in the later case, where as in the former case the current was in the direction to charge the capacitor.

18.6 TRANSIENT BEHAVIOUR OF SERIES LCR CIRCUIT

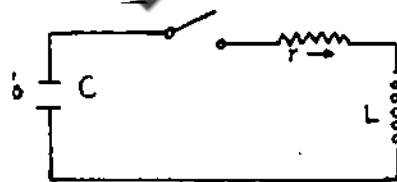

Fig 18.17 LCR Circuit

Initially, we charge the capacitor with a charge 'q' producing a voltage across the plates

$$V_0 = \frac{q_0}{C} \quad \dots (18.49)$$

At $t = 0$, the switch is closed and the charge q begins to leak off around the circuit through the inductance L , and the resistor R . Positive current will be defined clockwise

The second term in sinusoidal term expressed in complex -number notation.

We can rewrite equation 18.55 in a more concise form and take its derivatives as required for substitution in 18.54

$$V_c(t) = V_0 e^{(j\omega - \alpha)t}$$

$$\frac{dV_0}{dt} = (j\omega - \alpha) V_0 e^{(j\omega - \alpha)t}$$

$$\frac{d^2 V_0}{dt^2} = (j\omega - \alpha)^2 V_0 e^{(j\omega - \alpha)t}$$

Substitution in equation 18.54 and simplification gives

$$-\omega^2 - 2j\omega\alpha + \alpha^2 + \frac{R}{L}(j\omega - \alpha) + \frac{1}{LC} = 0$$

This equation has both real and imaginary terms. But a complex number can equal zero only if both real and imaginary parts are zero. We therefore separate the equation with real and imaginary parts. The imaginary part gives.

$$-2j\omega\alpha + \frac{1}{R} j\omega = 0$$

$$\text{or } \alpha = \frac{R}{2L}$$

the real part gives

$$-\omega^2 + \alpha^2 - \alpha \frac{R}{L} + \frac{1}{LC} = 0$$

Replacing α by R/L leads to

$$\omega^2 = \frac{1}{LC} - \frac{R^2}{4L^2}$$

These values of α and ω make proposed solution satisfy the differential equation.

We now see the condition for critical damping of the LCR circuit. Since oscillatory motion requires ω to be real, oscillations occur only if

$$\frac{1}{LC} > \frac{R^2}{4L^2}$$

Otherwise ω in equation 18.55 becomes imaginary, the exponent in the term $e^{j\omega t}$ becomes real and negative and the term become a damping term.

Whenever $1/LC$ exceeds $R^2/4L^2$ the voltage oscillates according to

$$V_c(t) = V_0 e^{-Rt/2L} e^{j\omega t}$$

If the terms $1/LC$ can be neglected in comparison with the resistive term, the solution becomes

$$V_0(t) = V_0 e^{-Rt/L}$$

SUMMARY

AC voltages are applied to the resistors, inductors and capacitors. Current passing through the resistive impedance inductive resistance and capacitive will be sinusoidal and in phase, lags by 90° and leads by 90° with respect to the applied voltage.

The transient behaviour of series LCR circuit is analogous to that of a damped mechanical oscillator

18.7 SAMPLE EXAMINATION QUESTIONS

I. Answer each of the following questions in detail.

1. Derive an expression for the energy stored in LR circuit.
2. Discuss the growth and decay of current in LR Circuits
3. Discuss about parallel LCR circuit and series response circuit
4. Derive an expression for the quality factor of series response LCR circuit.

II. Answer each of the following briefly

1. Give a graphical representation instantaneous voltage of a capacitor 'C'
2. Discuss the growth of current in CR Circuits
3. Write notes on i) Parallel LCR circuit ii) resonance circuit

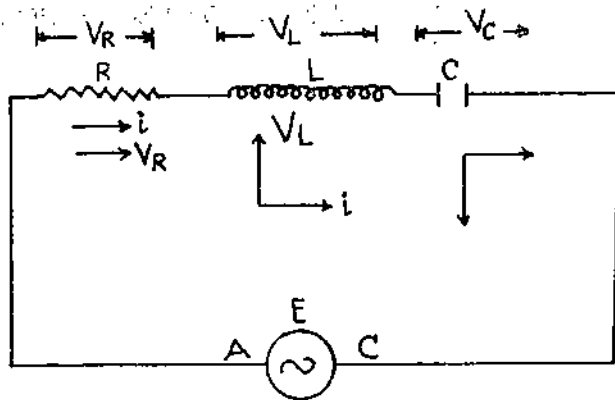

Fig 19.1 LCR Series Circuit

In a series circuit with no branches, the current – continuity equation $\Sigma i = 0$, leads to the result that everywhere in the circuit the current is the same. Thus for example, at a point A in the figure, the current coming from the left equals that going on to the right. This principle applies to all points in the circuit, such as B and C.

The AC current everywhere in the circuit thus has the same amplitude and phase. It can therefore be written in the form

$$i = I_0 \cos \omega t \quad \dots (19.1)$$

$$\text{Or } i = I_0 e^{j\omega t} \quad \dots (19.2)$$

But if the currents are everywhere the same, and if the phase and amplitude relations we have just developed for individual elements are to be obeyed. It follows that the AC voltage vectors for each elements must have different amplitudes and phases. In addition, the instantaneous values of voltages across each element must always add to equal the voltage of the generator. This satisfies the second circuit equations, as modified by the inclusion of voltages across the capacitor.

$$\Sigma E = \Sigma iR + \Sigma q/C \quad \dots (19.3)$$

The effect of inductance is contained in the left hand term. That is ΣE contains not only the generator emf but also the term $-L (di/dt)$

Since the voltage across each element is sinusoidal and has the same frequency, each voltage can be represented by rotating amplitude vector moving at the same frequency. Thus if the relative phase and amplitude of each voltage vector can be found and if the vector sum is made equal to and in phase with voltage source, the circuit equation will be satisfied at all times. Fig 19.2 reviews the current voltage relations for each circuit element at the same time. 't' the relative phase of V_R , V_L and V_C can be found by rotating.

In neither case the vector sum is given by the dotted vector labeled V_{AC} . The angle θ is the resultant phase difference between the current in any of the elements and the voltage across the combination V_{AC} .

According to the circuit equation this voltage V_{AC} must be just equal in phase and amplitude to the driving emf E . Therefore we may write

$$E = V_{AC} = V_R + V_L + V_C \quad \dots(19.4)$$

The magnitudes of these separate voltages are given by

$$V_R = RI_R$$

$$V_L = \omega LI_L$$

$$V_C = [I/\omega C]I \quad \dots(19.5)$$

But since

$$I_R = I_L = I_C = I_0 \quad \dots(19.6)$$

Equation 19.4 can be written as

$$E = I_0 [R + j\omega L + j(I/\omega C)] = I_0 Z \quad \dots(19.7)$$

The impedance terms have been written as vectors to allow for the different phases of the vectors. The meaning of this vector equations is shown in fig 19.5 (complex notation has been used). The diagram is identical with Fig 19.3 (a) except that each voltage vector is expressed as the current times the appropriate impedance term. It is apparent from the figure that the magnitude Z in equation 19.6 is given by

$$Z = \sqrt{R^2 + (\omega L - 1/\omega C)^2} \quad \dots(19.7)$$

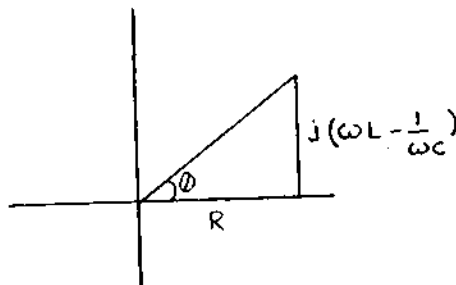
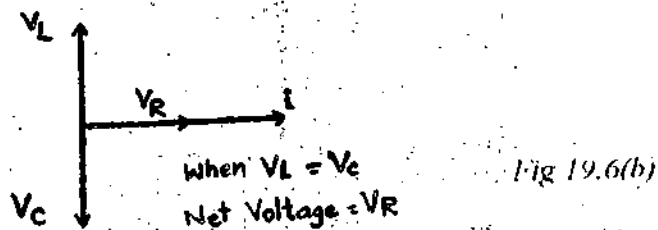

Fig 19.5

This is the AC impedance of three elements in series. The phase angle between the driving voltage and the current in the circuit is given by



In the case of this parallel circuit, the voltage rather than the current, which is the same on each element. As a result, the currents in three branches have different amplitudes and phase. If the amplitude applied voltage to the circuit is V_0 , the current amplitude in R, C and L will be

$$I_R = \frac{V_0}{R}$$

$$I_C = \frac{V_0}{X_C} = \frac{V_0}{1/j\omega C} \quad \dots(19.11)$$

$$I_L = \frac{-V_0}{j\omega L}$$

The requirements of the three currents at any instant is that they add to give the total current passing through the source of emf. This requirement is satisfied if the generating vectors of the three AC currents add vector ally equal the total current vector.

As in the last section, the relative phases of vectors can be obtained by rotating the current voltage diagrams of Fig 19.4 until the circuit requirements are met. In this case the requirement is that the phases of the voltage vectors of the three elements are same. Fig 19.7 shows the resulting current phase diagram, which is more convenient to use in the form of Fig 19.8

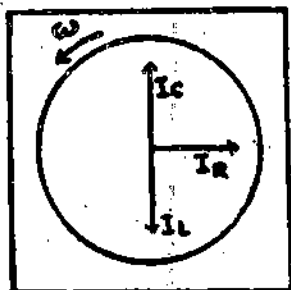

Fig 19.7

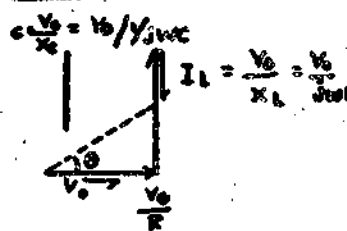

Fig 19.8

This diagram gives the basis of calculation of the total current in the circuit as follows. Using I_0 for the amplitude of the total current we write.

$$I_0 = I_R + I_C + I_L$$

$$= V_0 \left(\frac{1}{R} + \frac{1}{X_C} + \frac{1}{X_L} \right)$$

$$= V_0 \frac{1}{Z} \quad \dots(19.12)$$

The impedance terms are written as vectors to allow the phase information of Fig 19.4 to be induced, using this diagram, the reciprocal impedance can be evaluated as

Since $\omega L - \frac{1}{\omega C} = 0$, the magnitude of impedance is given by

$$Z = \sqrt{R^2 + (X_L - X_C)^2}$$

$$= \sqrt{R^2 + \left(\omega L - \frac{1}{\omega C}\right)^2}$$

The effective reactance or capacitive reactance depends upon

$$X_L > X_C \text{ or } X_L < X_C$$

The inductive reactance X_L is directly proportional to the frequency and increase as the frequency increases from zero on wards. The capacitive reactance is inversely proportional to the frequency, decrease from an infinite value downwards. At certain frequency both reactance's become equal and this frequency is called resonant frequency (f_r) At resonant frequency the two reactances are equal i.e. $X_L = X_C$ or $X_L - X_C = 0$ then

$$V_L = V_C \text{ (See Fig 19.9)}$$

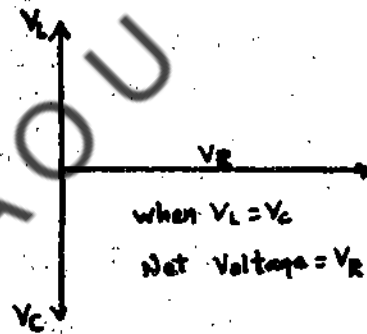

Fig 19.9

$$\omega L = \frac{1}{\omega C} \text{ or } \omega^2 = \frac{1}{LC}$$

$$\text{or } 2\pi f_r = \frac{1}{\sqrt{LC}} \text{ (as } \omega = 2\pi f) \quad \dots (19.20)$$

$$f_r = \frac{1}{2\pi \sqrt{LC}} \text{ Hz}$$

Where $X_L = X_C$ at resonant frequency. The impedance is minimum and equal to the resistance i.e $Z = R$.

Hence current in the circuit under these conditions is given by

$$i = \frac{V}{R}$$

$$= \frac{1}{R} \sqrt{\frac{1}{C}} \dots (19.22)$$

Generally, speaking the higher the Q value of the circuit, higher is the peak of its response as a function of driving frequency ω

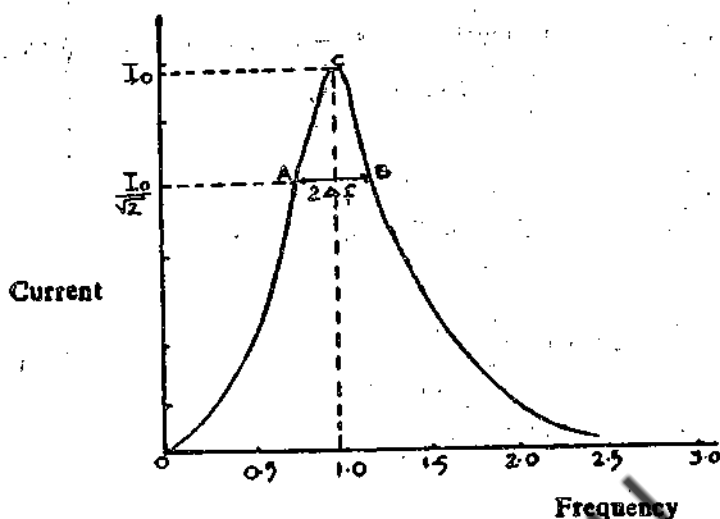

Fig 19.10

Figure 19.10 is a plot of the response (current) in case of an LCR circuit as a function of the frequency of the applied emf. It can be seen that the current and, hence, the power dissipation in the circuit is maximum at the point of resonance (C). Referred to this curve $\Delta\omega$ is the full width of the resonance peak at A,B where the power dissipation drops to half its peak value (or, where the current drops to $1/\sqrt{2}$ of its peak value).

19.7 PARALLEL RESONANCE CIRCUIT

A parallel resonance circuit is shown in Fig 19.11. It is assumed that the resistance of the inductance coil is negligible. The current in the inductance L will lag in phase by 90° to the applied voltage and is given by

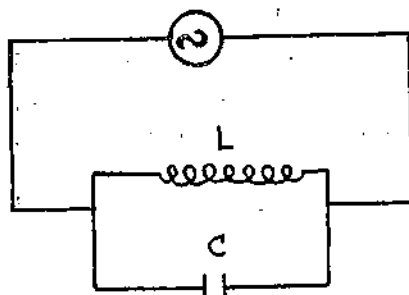

Fig 19.11

Check Your Progress:

1. Define Quality factor.
2. What are acceptor and rejector circuits.

Note: a) Space is given below for your answers.

b) Compare your answers with those given at the end of the chapter.

Example - 1:

In an LCR circuit if $L = .02$ Henries, $C = 0.5$ microfarads and $R = 10$ ohms and an alternating voltage of 200 volts is applied, find the frequency of the applied voltage to produce resonance. Find also the P.D. across the inductor and the capacitor.

Let f_r be the frequency of the applied voltage at resonance.

$$f_r = \frac{1}{2\pi\sqrt{LC}} = \frac{1}{2\pi \times 0.2 \times 0.5 \times 10^{-6}}$$
$$= 1.59 \times 10^3 \text{ c.p.s or Hz}$$

The current flowing through the circuit at resonance

$$i_r = \frac{200}{10} = 20 \text{ Amp}$$

P.D. across the inductor

$$= L \omega \times i_r$$
$$= 0.02 \times 2\pi f_r \times 20$$
$$= 0.02 \times 2\pi \times 1.59 \times 10^3 \times 20 = 4000 \text{ volts.}$$

P.D across the condenser plates

$$\frac{1}{C\omega} \times i_r$$
$$= \frac{20 \times \sqrt{0.02 \times 0.5 \times 10^{-6}}}{0.5 \times 10^{-6}} = 4000 \text{ volts}$$

UNIT 20: ZEROth AND FIRST LAW OF THERMO DYNAMICS

Contents

- 20.1 Objectives
- 20.2 Introduction
- 20.3 Thermal Equilibrium of a system
- 20.4 Adiabatic and Diathermic walls
- 20.5 Thermal Equilibrium between two systems
- 20.6 Zeroth law of thermodynamics
- 20.7 Concept of temperature
- 20.8 Measurement of temperature
- 20.9 Different types of thermometers
- 20.10 Nature of heat
- 20.11 Work done by a gas as it expands
- 20.12 Summary
- 20.13 Sample examination questions

20.1 OBJECTIVES

This Unit discusses the basic concepts of thermodynamics leading to the formulation of zeroth and first laws of thermodynamics. To make you understand the concepts the unit explains

- 1) the conditions under which a thermodynamic system will be in equilibrium;
- 2) the terms adiabatic and diathermic walls; and
- 3) concept of temperature.

After going through this Unit you should be able to

- 1) measure the temperatures using various methods; and
- 2) evaluate the amount of work done by a gas while expanding

20.2 INTRODUCTION

In recent times we have studied, in case of a flow of energy into a system, when system is working, that means heat energy converting into mechanical

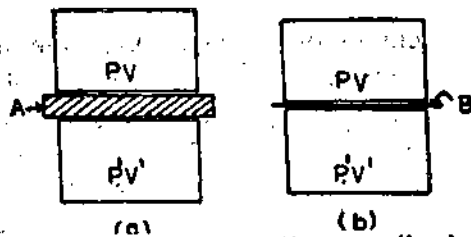

Fig 20.1

If two systems are brought into contact through a diathermic wall, normally the thermodynamic variables of the two systems are not compatible and they will go on changing till they become compatible. After compatible values are reached there will be no further change and the values of the thermodynamic variables will remain constant in time. The two systems will be in thermal equilibrium with each other.

20.5 THERMAL EQUILIBRIUM BETWEEN TWO SYSTEMS

Two systems are said to be in thermal equilibrium with each other when they are in contact with diathermic wall in between them and their thermodynamic variables are constant in time

20.6 ZEROth LAW OF THERMODYNAMICS

Let us suppose that we have two systems A and B with an adiabatic wall in between them. Let A and B are in contact with system C through a diathermic wall. The whole assembly is surrounded by an adiabatic wall Fig (20.2). After sometime systems A and B will come to thermal equilibrium with C. Now if we remove the adiabatic wall between A and B and put a diathermic one, there will be no further change. In other words A and B will be in thermal equilibrium with each other even if we first allow A and C to come to thermal equilibrium with each other and then allow B and C to come to thermal equilibrium with each other (Provided the state of C is unaltered through out)

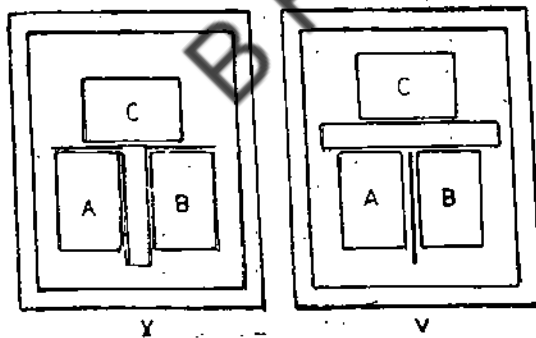

Fig 20.2

These results are stated in the form of a law which says "Two systems in thermal equilibrium with a third one are in thermal equilibrium with each other". R.H. Fowler called this as the Zeroth law of thermodynamics.

20.7 CONCEPT OF TEMPERATURE

When two systems come into thermal equilibrium with each other, some property of both the systems attains the same value. Thus when A is in thermal equilibrium with

$$T(X_r) = 273.16^0\text{K} \dots (20.4)$$

We get

$$T(X) = 273.16^0\text{K} \frac{X}{X_r} \dots (20.5)$$

20.9 DIFFERENT TYPES OF THERMOMETERS

If we use as a thermometer a system with two thermodynamic variables, for example, an amount of gas, it will be necessary to keep one of them constant and only allow the other to vary. Therefore x in case of a gas we can construct two types of thermometers. The first is the constant volume thermometer in which only pressure varies and we can measure temperature by the equation

$$T(P) = 273.16^0\text{K} \frac{P}{P_r} \dots (20.6)$$

The second is the constant pressure thermometer in which only the volume is allowed to vary and we get temperature from the equation

$$T(V) = 273.16^0\text{K} \frac{V}{V_r} \dots (20.7)$$

In addition to these there are systems in which the variation of a single physical property can be used to measure the temperature. Thus the volume expansion of a liquid is used to measure the temperature in the case of liquid in glass thermometers like the mercury thermometer. The change in electrical resistance of a wire is used to measure temperature in the platinum resistance thermometer. The increase in the length of rod can be used to measure temperature. The thermo e.m.f generated by a thermocouple is used to measure temperature in thermopiles. The variation in spectral composition (colour) of the light emitted by a body is used to measure temperature in pyrometers.

20.10 NATURE OF HEAT

We assume that when two systems at different temperatures are brought together, something flows from the system at higher temperature to the system at a lower temperature. This flow will continue till thermal equilibrium is established. We call the thing that flows from one system to the other because of temperature difference as heat.

In the early days people thought that heat was some sort of fluid. They called this fluid as calorie. A body which is at a higher temperature has this fluid at a higher pressure, and a body which is at lower temperature has this fluid at a lower pressure. Thus when two bodies which are at different temperatures are brought into diathermic contact, the calorie fluid flows from the body in which it is at higher pressure to the body in which it is at lower pressure till the pressures equalise.

In order to explain the production of heat by friction they said when bodies are rubbed together the caloric fluid contained in them is squeezed out and we feel therefore heat to be generated.

initial state to the final state in a process no heat supplied to or taken out from the system and U_f and U_i are the internal energies of the system in the final and initial states respectively, we have

$$dU = U_f - U_i = -dW_{i \rightarrow f} \quad \dots(20.9)$$

where dU is increase in the internal energy of the system.

First Law of thermodynamics

Now let us suppose that we do not surround the system by adiabatic walls but permit heat to enter or leave the system. Let us suppose an amount of heat dQ enters the system. Then dQ must be equal to the increase in the internal energy of the system plus the external work done by the system.

$$dQ = U_f - U_i + dW_{i \rightarrow f} \quad \dots(20.10)$$

or

$$dQ = dU + dW \quad \dots(20.11)$$

This is called the First law of thermodynamics

20.11 WORK DONE BY A GAS AS IT EXPANDS

Let us suppose that we have a cylinder containing a gas with a piston which can move freely (fig 20.3). The work done by the gas when the piston is pushed up by a distance dx is equal to

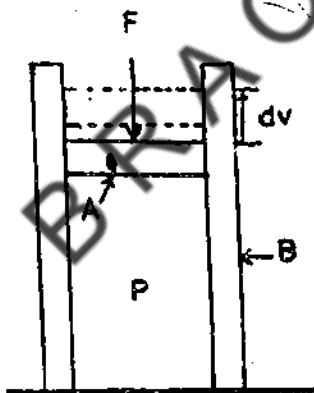

Fig 20.3

$$dW = \int_{dt} F \cdot dx = P A dx = P dV \quad \dots(20.12)$$

where A is the area of cross section of the cylinder and dv is the increase in volume. In general, as the volume of a gas increases its pressure does not remain constant. Therefore in order to calculate the total work done by a gas as it expands we have to integrate Pdv .

$$W = \int_{V_i}^{V_f} P dv \quad \dots(20.13)$$

This integral is graphically the area under the curve along which the system moves in the P - V diagram between the limits V_i and V_f (Fig 20.4)

BRAOU

BRAOU

UNIT- 21: REVERSIBLE AND IRREVERSIBLE PROCESSES

Contents

- 21.1 Objectives
- 21.2 Introduction
- 21.3 Reversible and irreversible process
- 21.4 Summary
- 21.5 Sample examination questions

21.1 OBJECTIVES

This Unit explains the reversible and irreversible processes.

After going through this unit you should be able to make out what reversible and irreversible processes are.

21.2 INTRODUCTION

A change in the physical or chemical state of a system can be brought about by a variety of processes. If the system does not interact with the surroundings, it is called a closed system. A process is said to be cyclic if the system returns to its original state after undergoing through a series of operations. Any actual process however complicated it is, may be considered to be equivalent to a sequence of simple processes. Simple process may be classified as (1) isothermal (change in temperature is zero) (2) isobaric (change in pressure is zero) (3) isochoric (change in volume is zero) and (4) adiabatic (no heat transfer between the system and its surroundings). These simple processes may be reversible or irreversible. In this Unit we study in detail what is meant by reversible and irreversible processes.

21.3 REVERSIBLE AND IRREVERSIBLE PROCESS

The characteristics of reversible and irreversible processes can be understood well by considering a typical thermodynamic system. Let us consider a real gas of mass M confined in a cylinder-piston arrangement of volume V . Let the pressure and temperature of the gas be P and T respectively. When this system is in an equilibrium state, the thermodynamic variables namely P, T, V remain constant with time. Let the cylinder m , whose walls are ideal heat insulators with the base being a good conductor be placed on a large heat reservoir maintained at temperature T , as illustrated in Fig 21.1. Let us now try to change the system to another equilibrium state in which the temperature T is the same as that of the initial state but the volume is reduced to half of its original volume. Out of many ways of achieving this two ways are quite important.

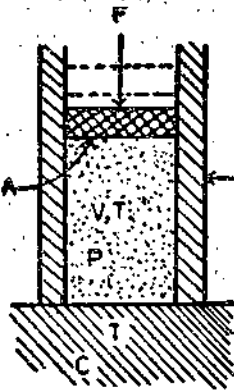

Fig.21.1

Process I: The piston is moved very rapidly. After some time the system comes into equilibrium with the reservoir. During the process the gas is turbulent and hence we can not well define the pressure and temperature. The process can not be represented as a continuous line on a $P - V$ diagram since we do not know what pressure the system would have had at a given volume. The system passes from one equilibrium state i to another equilibrium state f as illustrated in Fig 21.2 through a series of new equilibrium states.

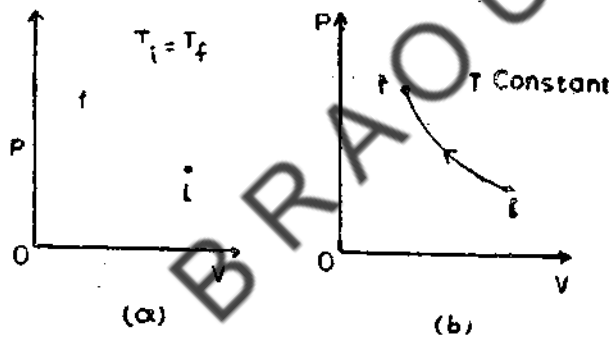

Fig 21.2

Process II. The piston is moved very slowly say by adding sand to the top of the piston. In this process the pressure, volume and temperature at all times could be well defined. Let a few grains of sand be added on the piston which is considered to be friction less. As a result the volume of the system reduces by a small amount leading to a small raise in temperature. The system departs from equilibrium state slightly. There will be transfer of heat from the system to the reservoir but with in a short period the system will reach a new equilibrium state, its temperature being of the reservoir. Let a few grains of sand be again added on to the piston. The volume of the gas in the system reduces. After some time the system comes to a new equilibrium state. By repeating the process in succession we can reduce the volume to half its value at the initial state. During this entire process the system is always in equilibrium with the reservoir. If the entire process is carried out with elemental changes in pressure, the intermediate state will depart from equilibrium even less. By indefinitely increasing the number of elemental changes, the size of each elemental change can be reduced correspondingly. This will lead to an ideal process in which the system passes through a continuous succession of equilibrium states.

process II let the piston be moved slowly downward by removing a few grains of sand on the piston. The external pressure will then be less than the internal pressure by dP . The gas expands and the system goes to an equilibrium state, which it had earlier while contracting. By successive elemental decrement of external pressure on the system by dP , we can trace back the equilibrium states through which the system has passed through earlier.

Process II is not only reversible but also isothermal because the temperature of the gas differs at all times by only a differential amount dT from the temperature of the reservoir on which the cylinder rests. In other words we can say that the process takes place at constant temperature.

The volume of the gas in the system can also be reduced adiabatically by keeping the cylinders on a non-conducting platform say sand. In an adiabatic process no heat is allowed to enter or leave the system. An adiabatic process can be either reversible or irreversible. In a reversible adiabatic process the piston is moved exceedingly slowly by employing the sand-loading technique. In the irreversible adiabatic process the piston is pushed down quickly.

In an adiabatic compression the temperature of the gas increases, because as per the first law of thermodynamics, the work W done in pushing down the piston must appear as an increase dU in the internal energy of the system. W will have different values for different rates of pushing down the piston. Hence dU and the corresponding change dT will not be the same for reversible and irreversible adiabatic processes.

A process whether reversible or irreversible depends upon the state of the system and the nature of the process. Only reversible processes can be mathematically described in thermodynamics or represented by means of graphs like Fig 21.2b. It is a matter of concern to know why all naturally occurring processes in thermodynamics are irreversible, particularly when in dynamical processes reversibility can be at least progressively attained as a final limit by eliminating friction in elasticity etc. As per Boltzmann, irreversibility is confined to the behaviour of the complex structure like a gas treated as a whole and is not to be expected in the behaviour of the individual molecules and arises from our inability to deal with individual molecules. It is also worth while to note here that in the irreversible process, reversibility is not impossible, but is almost infinitely improbable.

21.4 SUMMARY

A change in the physical or chemical state of a system can be brought about by a variety of processes. If the system does not interact with the surroundings it is called a closed system. A process is cyclic if the system returns to its original state after undergoing through a series of operations. The direction of thermodynamically reversible process can be reversed by an infinite change in one of the properties of the system.

UNIT-22: CARNOT'S ENGINE

Contents

- 22.1 Objectives
- 22.2 Introduction
- 22.3 Carnot's Cycle
- 22.4 Reversibility of Carnot's Cycle
- 22. Efficiency of heat engines
- 22. Carnot's theorem
- 22. Summary
- 22. Sample examination questions

22. OBJECTIVES

This Unit discusses how the efficiency of a heat engine can be estimated.

In order to make you understand it explains what is Carnot Cycle, and

- 1) how it is useful in converting heat into energy; and
- 2) the factors that control the efficiency of heat engines.

After going through this Unit you should be able to understand

- 1) on what principle a refrigerator works; and
- 2) the efficiency of heat engine depends on the temperatures of hot and cold bodies and not on the working substances.

2.2 INTRODUCTION

The laws of thermodynamics have a negative quality, which distinguishes them from other laws of physics. The first law of thermodynamics may be stated as that energy cannot be destroyed. The second law of thermodynamics also has this negative aspect where in we can state the law that the spontaneous tendency of a system to go towards thermodynamic equilibrium *can not be reversed* at the same time without changing some organised energy say work, into disordered energy say heat. The discovery of heat engines and their application to various industrial processes enabled the formulation of second law of thermodynamics. Heat engines function on the principle of conversion of heat energy into mechanical energy. Modern steam engines used in locomotive, gas turbines employed in large electric power stations and in big ships and internal combustion engines used in motor cars and aeroplanes all have the common feature of conversion of heat energy into mechanical energy.

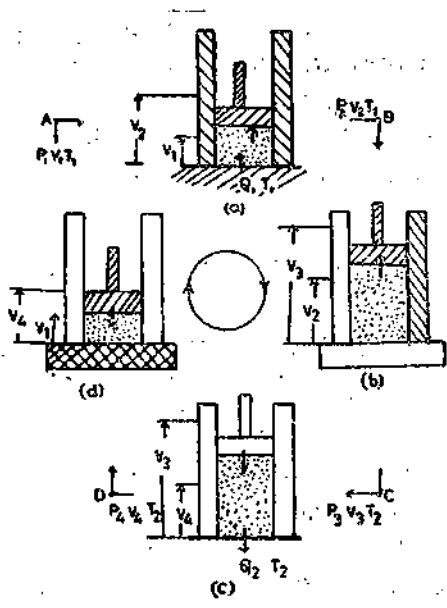

Fig 22.2

Step 1: To start with let the gas inside the cylinder be in an equilibrium state whose pressure, volume and temperature represented are P_1 , V_1 and T_1 respectively. This state is represented by the point A in the P-V diagram illustrated in Fig 22.3. Let the system be placed on the heat reservoir at temperature T_1 , as shown in Fig 22.2a and the gas be allowed to expand slowly. The process is reversible isothermal expansion. Let the expansion take place for some time when the pressure, volume and temperature attain the values P_2 , V_2 and T_1 . This state is represented by the point B in Fig 22.3. During this process heat energy Q_1 is absorbed by the gas by conduction through the base. Since the expansion is isothermal at T_1 the gas does work in raising the piston and its load.

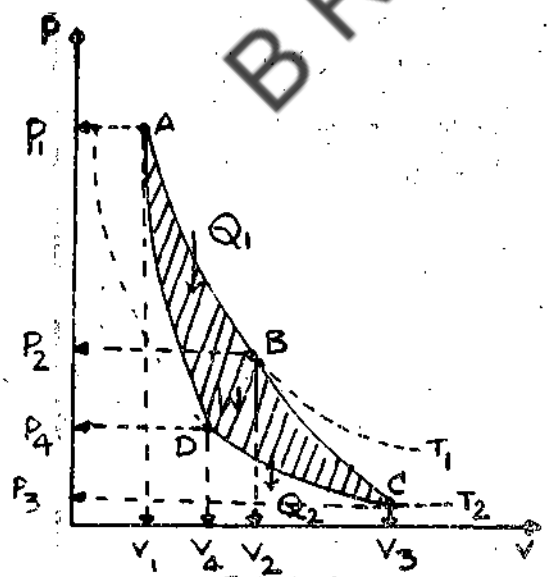

Fig 22.3.

Step 2: The system is put on a non-conducting stand and the gas is allowed to expand slowly to $P_3V_3T_2$. This state is represented by the point C in Fig 22.3. The expansion is reversible adiabatic process. The gas does work in raising the piston and hence its temperature falls from T_1 to T_2

22.4 REVERSIBILITY OF CARNOT CYCLE

Since the processes, isothermal expansion, adiabatic expansion, isothermal compression and adiabatic compression are reversible processes because of total absence of friction between the piston and the cylinder, the Carnot Cycle can be made perfectly reversible. Starting from the point A on the P-V diagram shown in Fig 22.3 the Carnot Cycle can be traced back in succession along the line A D C B A. The sequence of processes are (1) adiabatic expansion (A to D) (2) isothermal compression (D to C) (3) adiabatic compression (C to B) and (4) isothermal compression (B to A). In this process an amount of heat Q_2 is removed from the reservoir kept at lower temperature T_2 and an amount of heat Q_1 is delivered to the reservoir kept at higher temperature T_1 . In the reversed Carnot Cycle work must be done on the system which extracts heat from the reservoir at low temperature. Any amount of heat can be removed from the lower temperature reservoir by repeating the reverse cycle. Thus the system functions as a refrigerator transferring from a body at a lower temperature that is freezing compartment to one at high temperature that is the room by means of work supplied to it in the form of electrical energy.

22.5 EFFICIENCY OF HEAT ENGINES

The efficiency of a heat engine η can be defined as the ratio of the net work done by the engine during one cycle to the heat taken in from the high temperature source in one cycle.

For the ideal Carnot engine we have

$$\eta = \frac{W}{Q_1} = \frac{Q_1 - Q_2}{Q_1} = 1 - \frac{Q_2}{Q_1} \quad \dots (22.2)$$

Since $Q_1 > Q_2$ the efficiency of a heat engine is less than 1 so long as the heat Q_2 delivered to the exhaust is not zero. A study of all practical heat engine indicates that energy heat engine rejects some heat during the exhaust stroke. This is the amount of heat absorbed by the engine, which is not converted into work in the process

The efficiency of Carnot engine can also be expressed in terms of the temperatures T_1 and T_2 of the source and sink.

Referring to Fig 22.3 when the system is taken through the path A B by reversible isothermal expansion process, the temperature and internal energy of the ideal gas remain constant. As per the first law of thermodynamics the heat Q_1 , absorbed by the gas in its expansion must be equal to the work W_1 , done in this expansion. Hence,

$$Q_1 = W_1 = MRT_1 \log \left(\frac{V_2}{V_1} \right) \quad \dots (22.3)$$

Where M is the mass of the gas in moles and R is called gas constant. The value of R is $8.314 \text{ Jmol}^{-1}\text{K}^{-1}$

Example 1:

Calculate the theoretic efficiency of a steam engine operating at 10 atmosphere at which pressure water boils at 180°C . The temperature of the condenser is 30°C .

The efficiency of heat engine can be expressed as

$$\eta = \frac{T_1 - T_2}{T_1} = \frac{(273 + 180) - (273 + 30)}{(273 + 180)}$$

$$\eta = \frac{453 - 303}{453} = 0.33$$

The efficiency of the heat engine is 33%

Example 2:

A Carnot Cycle uses 1 mole of an ideal gas whose $C_v = 25 \text{ J mole}^{-1} \text{ K}^{-1}$ as the working substance. It operates from the most compressed stage of 10 atm. Pressures and 500 K. It expands isothermally to a pressure of 1 atm. and then adiabatically reaches a most expanded stage at a temperature of 300 K. Determine the numerical values of heat and work done in each stroke. Determine the efficiency of the system.

The data given in the problem is presented in Fig 22.4

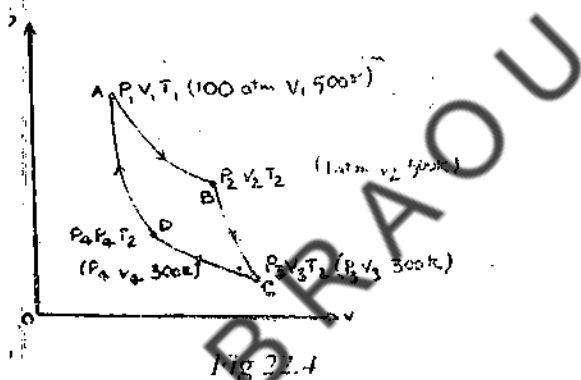

The work done by the gas when the system goes from A to B in the isothermal expansion process.

$$W_1 = \int P dV = MRT_1 \int_{V_1}^{V_2} \frac{dV}{V} = MRT_1 \log \frac{V_2}{V_1}$$

Since the gas contained in the cylinder is one mole $M = 1$. For the isothermal process we have $P_1 V_1 = P_2 V_2$. Hence $\frac{V_2}{V_1} = \frac{P_1}{P_2}$

$$\text{Therefore } W_1 = RT_1 \log_e \frac{P_1}{P_2} = 2.303 RT_1 \log_{10} \frac{P_1}{P_2}$$

22.6 CARNOT'S THEOREM

From the study of practical heat engines and the analysis of the ideal, Carnot engines Carnot proposed a theorem regarding the efficiency of heat engines. The Carnot's theorem may be stated as that the efficiency of reversible engines operating between the same two temperatures is the same and no irreversible engine working between the same two temperatures can have a greater efficiency than the reversible engine. Clausius and Kelvin showed that the above theorem was a necessary consequence of second law of thermodynamics. The efficiency of a reversible engine is independent of the working substance and depends only on the temperatures.

To prove the Carnot's theorem let us consider two reversible engines E and E' as shown in Fig 22.5

The engines E and E' operate between the temperatures T_1 and T_2 where $T_1 > T_2$. The engines may differ in their working substance, or in their initial pressures and lengths of stroke. Let the engine E runs in the forward direction (direct Carnot Cycle of operation) and let the

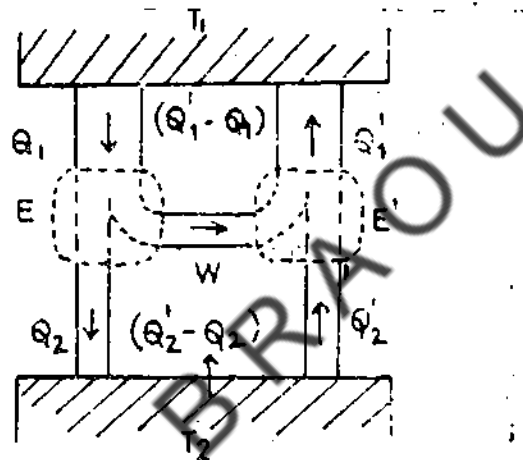

Fig 22.5

Engine E' runs in the backward direction (reverse Carnot cycle of operation). The engine E takes heat Q_1 at T_1 and gives out heat energy Q_2 at T_2 . The backward running engine E' (say refrigerator) takes heat Q_2 at T_2 and give out heat Q_1 , at T_1 . Let the engines E and E' be connected mechanically as shown in Fig 22.5 and the stroke lengths be adjusted so that the work done per cycle by E is just sufficient to operate E'

Let us assume that the efficiency of E say η be, greater than the efficiency of E' say η'

$$\eta > \eta' \quad \dots(22.7)$$

$$\text{Then } \frac{Q_1 - Q_2}{Q_1} > \frac{Q_1' - Q_2'}{Q_1'} \quad \dots(22.18)$$

Since the work done per cycle by one engine is equal to the work done per cycle by the other engine. We have

The actual efficiency of the heat engine is less than the maximum efficiency, which is possible only under ideal conditions. Energy is lost by friction, turbulence and heat conduction. In steam engines the usual efficiency attainable is above 15%. Lower exhaust temperatures or more complicated steam engines may raise the maximum efficiency attainable to 35% and actual efficiency realisable to 20%. The actual efficiency of ordinary automobile engine attainable is about 22%. In the case of large diesel oil engine actual efficiency realisable is about 40%.

22.7 SUMMARY

Carnot's Cycle is useful in converting heat into energy. Carnot's Cycle is a reversible cycle consisting of four process namely (1) isothermal expansion (2) adiabatic compression (3) isothermal compression (4) adiabatic expansion

The work done by Carnot engine is given $W = Q_1 - Q_2$. Where Q_1 is the heat gained by the system from high temperature heat source and Q_2 is the heat given out by the system to lower temperature heat link. The efficiency of heat engine is given by

$$\eta = \frac{T_1 - T_2}{T_1} \cdot \frac{Q_1 - Q_2}{Q_1}$$
The efficiency of heat engine depends on the temperature of hot and cold bodies and is independent of working substance.

Carnot's theorem may be stated as the efficiency of reversible engine operating between the same two temperatures is the same and no irreversible engine working between the same two temperatures can have a greater efficiency than the reversible engine.

22.8 SAMPLE EXAMINATION QUESTIONS

I. Answer the following questions in detail.

1. Show that in a Carnot Cycle the net work done by the system is equal to the difference of heat gained by system at temperature T_1 and the heat given out by the system at temperature T_2 .
2. State and prove Carnot's theorem.
3. Define what is meant by efficiency of a heat engine. Derive an expression for the efficiency of the heat engine for the efficiency of the heat engine in terms of temperature of the source and sink.

II Solve the following problems

1. An ideal heat engine operates in a Carnot cycle between 300 and 150°C. It absorbs 50×10^3 J of heat at the higher temperature. How much work per cycle is turned out by this engine.

(Ans: 13.1 J)

UNIT – 23: SECOND LAW OF THERMODYNAMICS AND ENTROPY

Contents

- 23.1 Objectives
- 23.2 Introduction
- 23.3. Formulation of second law of thermodynamics
- 23.4. Thermodynamics temperature scale
- 23.5 Definition of Entropy
- 23.6 Change in Entropy in a Reversible Process.
- 23.7 Change in Entropy in an Irreversible Process.
- 23.8 Second law of thermodynamics in terms of Entropy
- 23.9 Entropy and Disorder
- 23.10 Summary
- 23.11. Sample examination questions

23.1 OBJECTIVES

This Unit discusses the formulation of second law of thermodynamics and its application. Also discusses the concept of entropy and its application in understanding the second law of thermodynamics.

To make you understand the concept this Unit explains

- (1) Formation of second law of thermodynamics
- (2) What is meant by entropy and how it changes in reversible and irreversible processes and
- (3) The second law of thermodynamics in terms of Entropy

After going through this unit you will be able to explain thermodynamic temperature scale, and make out that the Entropy is a measure of disorder.

23.2 INTRODUCTION

The first law of thermodynamics establishes the internal convertibility of heat and work. Experience tells us that no law achieves 100% efficiency in converting work into heat. For example: by devising a machine whose sole function is to create friction between moving part. The convert process, that is complete conversion of heat into work, has not been found possible. Investigations on the possibility to achieve complete conversion of heat into work led to the formulation of second law of thermodynamics. The formulation of

Or

$$\frac{Q_1}{Q_2} = \frac{1}{1 - f(\theta_1, \theta_3)} = F(\theta_1, \theta_2) \quad \dots(23.4)$$

Where F denotes some other function of θ_1, θ_2 . For a reversible engine working between θ_1 and θ_3 . Where $\theta_2 > \theta_3$, we have

$$\frac{Q_2}{Q_3} = F(\theta_2, \theta_3) \quad \dots(23.5)$$

For a reversible engine working between θ_1 and θ_3 where $\theta_1 > \theta_3$ we have

$$\frac{Q_1}{Q_3} = F(\theta_1, \theta_3) \quad \dots(23.6)$$

Multiply Eqs and 23.2 and 24.5 we get

$$\frac{Q_1}{Q_2} \times \frac{Q_2}{Q_3} = \frac{Q_1}{Q_3} = F(\theta_1, \theta_3) = F(\theta_1, \theta_2) \times F(\theta_2, \theta_3) \quad \dots(23.7)$$

Eq. 23.7 is valid only if

$$F(\theta_1, \theta_2) = \frac{\phi(\theta_1)}{\phi(\theta_2)} \quad \dots(23.8)$$

Where ϕ is another function of temperature. Therefore, for any reversible engine we can write

$$\frac{Q_1}{Q_2} = \frac{\phi(\theta_1)}{\phi(\theta_2)} \quad \dots(23.9)$$

Since $\theta_1 > \theta_2$ and $Q_1 > Q_2$ we have $\phi(\theta_1) > \phi(\theta_2)$.

This indicates that $\phi(\theta)$ is a linear function of θ and may be used to measure the temperature. Let $\phi(\theta)$ be denoted by τ . Then Eq 23.9 becomes.

$$\frac{Q_1}{Q_2} = \frac{\tau_1}{\tau_2} \quad \dots(23.10)$$

Equation 23.10 can be used to define a new scale of temperature τ , which is called thermodynamic scale or Kelvin scale. This scale is independent of the properties of any particular substance and Eq. 23.10 is universally true. The ratio of any two temperatures on this scale is equal to the ratio of heats taken in and rejected out by an engine working reversibly between these two temperatures.

The zero of Kelvin's temperature scale i.e., $\tau = 0$ is that temperature at which $Q_2 = 0$. Hence $W = Q_1$. Thus all the heat taken by the engine has been converted into work and the efficiency of the engine is 100% i.e $\tau = 1$. τ Cannot be less than 0, that is negative since Q_2 becomes negative implying that the engine would draw heat both from the source and the

The above theoretically developed Kelvin's temperature scale can be realized in practice since it agrees completely with the perfect gas scale as proved below.

For a reversible engine-containing perfect gas as the working substance the efficiency η can be given by

$$\eta = 1 - \frac{Q_2}{Q_1} = 1 - \frac{T_2}{T_1} \quad \dots(23.11)$$

Where T_1 and T_2 represent the temperature of the source and sink measured on the perfect-gas scale. As per Eq 23.11 we get

$$\frac{T_1}{T_2} = \frac{T_1}{T_2} \quad \dots\dots(23.12)$$

Eq.23.12 indicates that the ratio of any two temperatures on the perfect gas scale and the thermodynamic gas scale are equal. If $\tau = 0$, and hence the zero of the thermodynamic scale coincides with the zero of the perfect gas scale. If T_1, T_2 represents the temperatures of boiling point of water and melting point of ice measured on the perfect gas scale we have

$$T_1 - T_2 = 100 \quad \dots(23.13)$$

On the Kelvins temperature scale we have for the two fixed points

$$T_1 - T_2 = 100 \quad \dots\dots\dots(23.14)$$

We can write

$$\eta = \frac{T_1 - T_2}{T_1} = \frac{100}{T_1} \quad \dots(23.15)$$

And also

$$\eta = \frac{T_1 - T_2}{T_1} = \frac{100}{T_1}$$

Eqs. 23.15 and 24.16 indicate that the temperatures of the boiling point of water and the melting point of ice are identical on the two scales. Hence, any temperatures has the same value on the two scales and hence the two scales as identical. The melting point of ice given in Clausius scale as 0°C is equal to 273.15 K in that Kelvin's temperature scale.

It is worthwhile to note here that the fundamental feature of all cooling processes in that, the lower the temperature, the more difficult it is to go still lower. This practical experience has led to the formulation of the third law of thermodynamics. It can be states as that it is impossible by any procedure, however idealized it may be, to reduce any system to the absolute zero of temperature in a finite number of operations. Since we cannot have a sink at absolute zero, to realize a heat engine with 100^0 efficiency is a practical impossibility.

$$\sum \frac{Q}{T} = 0 \quad \dots (23.18)$$

In the limit of infinite small temperature difference between the isotherms we get

$$\oint \frac{dQ}{T} \quad \dots (23.19)$$

The sign (signified integration around a complete cycle. A zero value for a cyclic integral implies that the function being integrated is independent of the path over which the integration is made. Such a function is called a state function a thermodynamic property. This thermodynamic property is called entropy and hence we have

$$ds = \frac{dQ}{T} \quad \dots (23.20)$$

And

$$\oint ds = 0 \quad \dots (23.21)$$

The units of entropy is $J K^{-1}$

Entropy may be defined as that thermal property of a substance which remains constant when the substance undergoes adiabatic changes since heat is neither communicated to the system nor taken away from it. It is a physical quantity which can not be felt like temperature and pressure. It is a definite single valued function of the thermodynamic co-ordinates which define the state of the substance namely temperature, pressure volume and internal energy.

23.6 CHANGE IN ENTROPY IN A REVERSIBLE PROCESS

Consider any two equilibrium states A and B of a system and the paths connecting them are reversible as shown in Fig 23.7. For this type of system where the process is a reversible process we have

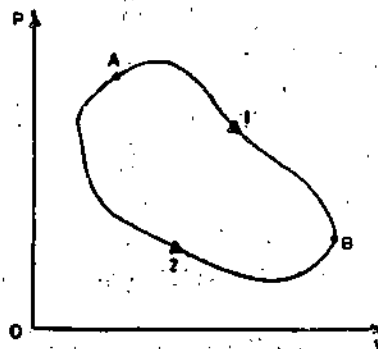

Fig 23.7

$$S_B - S_A = \Delta S_{AB} = -\Delta S_{AB} \quad \dots (23.28)$$

Eqn. 23.14 indicates that the heat which is absorbed or lost by the system during the process A B must be transferred reversibly from or to the surrounding. Hence in any process carried out reversibly, the entropy gained or lost by the system must be lost or gained by the surroundings. Hence the sum of entropy changes of the system and the surroundings must be zero. Hence

$$\Delta S_{AB} (\text{System}) = -\Delta S_{AB} (\text{Surroundings}) \quad \dots (23.29)$$

$$\Delta S_{\text{Total}} = \Delta S_{\text{System}} + \Delta S_{\text{Surroundings}} \quad \dots (23.30)$$

Example - 1

Determine the change in entropy in the conversion of 1 mole of liquid water at 100°C To vapour 100°C at 1 atm pressure
The system consists of 1 mole of water and the surroundings consist of a heat reservoir at 100°C as shown in fig 23.8.

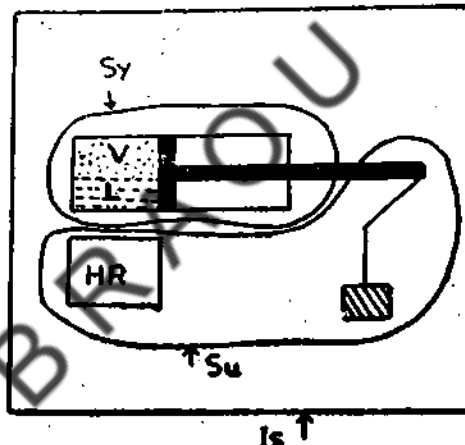

Fig 23.8

The temperature gradient between heat reservoir and the water is infinitesimally small. Hence the system absorbs the necessary heat from the reservoir reversibly and the water gets converted into vapor.

The Change in entropy of the system.

$$\Delta S = \int \frac{dQ}{T}$$

Since T is constant

$$\Delta S = \frac{1}{T} \int dQ = \frac{Q}{T}$$

$$\Delta S_{\text{cold body}} = \frac{Q_2}{T_2} \quad \dots(23.32)$$

The entropy change of the system

$$\Delta S_{\text{system}} = \Delta S_{\text{hot body}} + \Delta S_{\text{cold body}} \quad \dots (23.33)$$

$$\Delta S_{\text{System}} = - \frac{Q}{T_1} + \frac{Q}{T_2} = Q \left[\frac{1}{T_2} - \frac{1}{T_1} \right] \quad \dots(23.34)$$

$$\text{Since } T_1 > T_2 \quad \dots(23.35)$$

$$\Delta S_{\text{System}} > 0 \quad \dots (23.36)$$

In the irreversible adiabatic heat conduction process the entropy of the system increases.

(II) Free expansion.

Consider an ideal gas of volume V_1 expand into vacuum and let the final volume be V_2 . Since no work is done on the system in the expansion process and the gas is enclosed by non-conducting walls as shown in Fig 23.10

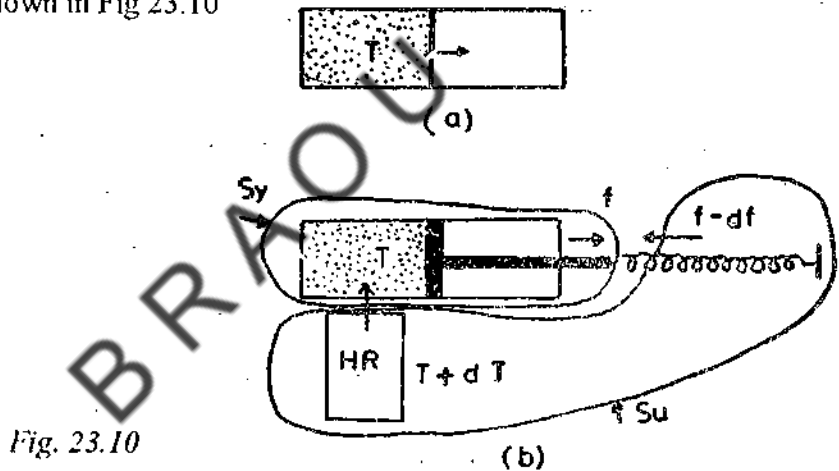

Fig. 23.10

$F.Q = 0$ From the first law of thermodynamics $\Delta U = 0$ that is $U_i = U_f$ where i and f represent the initial and final states. Since the gas is an ideal U depends on the temperature and not on volume or pressure. Hence the temperature of initial and final states is the same i.e. $T_i = T_f = T$.

The free expansion is an irreversible process. There occurs a change in entropy of the system when the volume changes from V_1 to V_2 . We can not analyse this process directly to find the entropy difference between the expanded gas and the initial gas. It is necessary to think of a process which can be carried out reversibly that takes the system from the same initial state to the same final state as in free expansion. Fig 23.5b. illustrates how this can be achieved. This is an isothermal process. The heat absorbed can be calculated based on first law of thermodynamics. Thus

$$dQ = dw = PdV = \mu RT \frac{dV}{V} \quad \dots(23.37)$$

In terms of disorder we can calculate the change in entropy of an ideal gas in an isothermal expansion. In this process the number of molecules (N) and the temperature (T) remain constant and volume alone changes. The probability that molecule can be found in a volume V is proportional to W . Hence the probability of finding a single molecule in V is given by

$$W1 = cV \quad \dots(23.44)$$

Where c is constant. The probability of finding N molecules simultaneously in the volume V is W given by

$$W = W^N = (cV)^N \quad \dots(23.45)$$

Substituting Eq. 23.45 in Eq 23.43. we get

$$S = K \cdot N \log c V = KN (\log C + \log V) \quad \dots(23.46)$$

The difference in entropy between a state of volume V_f and a state of volume V_i when T and N are constant can be given by

$$S_f - S_i = KN (\log C + \log V_f) - KN (\log C + \log V_i) \quad \dots(23.47)$$

Or

$$S_f - S_i = KN \log \frac{V_f}{V_i} = \frac{RN}{N_0} \log \frac{V_f}{V_i} \quad \dots(23.48)$$

$$S_f - S_i = \mu R \log \frac{V_f}{V_i} \quad \dots(23.49)$$

Where N_0 represents the Avagadro's number

Eq. 23.39 is the same as the Eq (23.39)

Due to irreversible expansion if the volume of the gas doubles then W goes from $(C_1V)^N$ to $(C_2V)^N$. Since W represents disorder, it increases in the natural process of free expansion. The second law of thermodynamics can be stated based on statistical mechanics. The direction in which natural process take place is determined by the laws of probability that is towards a more probable state. The equilibrium state is the state of maximum entropy thermodynamically and the most probable state statistically. Hence second law of thermodynamics shows us the most probable course of events and not the only possible ones.

23.10 SUMMARY

It is impossible to construct a device which operating on a cycle, will produce no other effect than the extraction of heat from a reservoir and the performance of an equivalent amount of work (According to Kelvin).

for reversible adiabatic process and

$$S_f > S_i$$

... (23.42)

for irreversible adiabatic process. Where S_i and S_f represent the initial and final entropies of the system.

The statement of second law in terms of entropy of the system is consistent with the statement of Clausius that there is no such thing as perfect refrigerator. If there exists a perfect refrigerator then the entropy of the lower temperature reservoir should decrease by Q/T_2 and that of the upper temperature reservoir should increase by Q/T_1 . The entropy of the system should remain constant since it undergoes a complete cycle. Hence the net change in the entropy of the system plus environment is a decrease. This violates the principle of second law and if the law is to be retained as applicable then there is no such thing as perfect refrigerator.

The statement of second law in terms of entropy of the system is also consistent with Kelvin-Planck statement, which implies that there is no such thing as perfect heat engine. If there is a perfect heat engine then the entropy of the reservoir at temperature T should decrease by Q/t where as the entropy of the system remains unchanged giving rise to a net decrease in entropy of the system plus environment. This violates the second law stated in terms of entropy and hence there is no such thing as a perfect heat engine.

Example - 2.

Determine the entropy change of a system consisting of 5Kg of ice at 0°C which melts, irreversibly to water at 0°C . The latent heat of melting is 333 J/g. Since ice is made to melt irreversibly, it must be kept in contact with a heat reservoir whose temperature is 0°C by only a differential amount. When the temperature of the reservoir is lowered by a differential amount the melted ice begins to freeze. Since the process is reversible the change in entropy.

$$\Delta S = \int_0^T \frac{dQ}{T} = \frac{Q}{T}$$

$$\text{now } Q = 5 \times 10^3 \text{ g} \times 333 \text{ J/g} = 1665 \times 10^6 \text{ J}$$

$$\Delta S_{\text{System}} = - \frac{1.665 \times 10^6 \text{ J}}{273^\circ \text{K}} = - 6.1 \times 10^3 \text{ J.K}^{-1}$$

The change in entropy of the environment

$$\Delta S_{\text{environment}} = - \frac{1.665 \times 10^6 \text{ J}}{273^\circ \text{K}} = - 6.1 \times 10^3 \text{ J.K}^{-1}$$

The net change in the entropy of the system plus reservoir is zero

In practice melting of ice is an irreversible process. Suppose ice is made to melt in a glass of water, the entropy of the system plus environment in this case increases.

UNIT: 24 - THERMODYNAMIC POTENTIALS

Contents

- 24.1 Objectives
- 24.2 Introduction
- 24.3 Thermodynamic Potentials
- 24.4 Summary
- 24.5 Sample examination questions

24.1 OBJECTIVES

This unit discusses the equation for thermodynamic potentials and their derivation by combining the 1st Law of thermodynamics and Carnot's theorem.

After going through this Unit you should be able to find out the mathematical relation between E, H, A and G.

24.2 INTRODUCTION

Many useful thermodynamic relations can be obtained based on the laws of thermodynamics and the properties of the system. From the first law of thermodynamics we have

$$dE = dQ + dW \quad \dots(24.1)$$

Where dE represents the change in energy of the system dQ represents the elemental heat produced and dW represents the elemental work done. Eq. 24.1 applies to both reversible and irreversible process.

For a reversible process we have, based on Carnot's theorem.

$$dQ = T ds \quad \dots(24.2)$$

If P represents the pressure and V represents the volume of the system then the work done on the system.

$$dW = -PdV \quad \dots(24.3)$$

Substituting Eqs. 24.2 and 24.3 in Eq. 24.1 we get

$$dE = Tds - pdv \quad \dots(24.4)$$

or

$$dH = TdS + VdP \quad \dots(24.12)$$

Comparing Eqs. 24.8 and 24.12 we get

$$\left(\frac{dH}{dP}\right)_p = T \quad \dots(24.13)$$

and

$$\left(\frac{dH}{dP}\right)_s = V \quad \dots(24.14)$$

The Helmholtz free energy of the system A is characteristic function of T and V. It is defined as

$$A(T,V) = E - TS \quad \dots(24.15)$$

Since

$$A = A(T,V)$$

We can write

$$dA = \left(\frac{dA}{dT}\right)_V dT + \left(\frac{dA}{dV}\right)_T dV \quad \dots(24.16)$$

Also since

$$A = E - TS \quad \dots(24.17)$$

$$dA = dE - TdS - SdT \quad \dots(24.18)$$

Using Eq. 24.4 in Eq. 24.18 we get

$$dA = TdS - PdV - TdS - SdT$$

$$\text{or} \quad \dots(24.20)$$

$$dA = -PdV - SdT$$

Comparing Eqs. 24.16 and 24.20 we get

$$\left(\frac{dA}{dT}\right)_V = -S \quad \dots(24.21)$$

and

The parameters E , H , A and G are called the thermodynamic potentials. The sequence for transformations leading to these thermodynamic potentials was first devised by Gibbs. From a knowledge of any one of these potentials as a function of its natural variables one can calculate the other thermodynamic potentials. To illustrate if $E(S, V)$ is known we can determine $T(S, V)$ and $P(S, V)$ from Eqs 24.5 and 24.6. By eliminating S from the equation 24.5 and 24.6 we can get the equation of the state $F(P, V, T) = 0$

Since conditions of constant pressure are more prevalent than the conditions of constant volume, H and G occur more naturally in experimental thermodynamics than E and A .

Since volume can be more easily defined theoretically than pressure, E and A are more fundamental quantities in statistical thermodynamics. A and G are important in the study of thermodynamic equilibrium. The four differential expressions

$$dE = TdS - PdV$$

$$dH = TdS + VdP$$

$$dA = -SdT - PdV$$

$$dG = -SdT + VdP$$

Provide a starting point for the derivation of many useful relationships among thermodynamic variables. To remember the above differential relations a device can be used as illustrated in 24.1

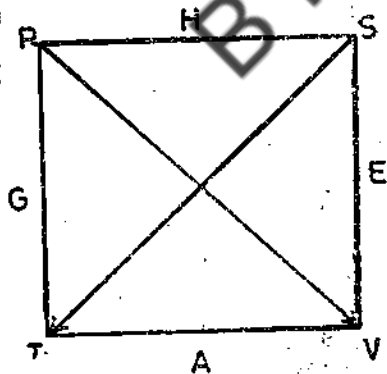

Fig 24.1.

The four independent variables P, S, T, V (in alphabetical order) are placed at the corners of a square. The potentials E, H, A, G are placed at the sides such that each lies between its natural variables. To write the differential expression for the potentials multiply the differential of each independent variable by the quantity diagonally opposite. Add if the diagonal move follows an arrow and subtract if it opposes an arrow. To

UNIT- 25: MAXWELL'S THERMODYNAMIC EQUATIONS AND APPLICATIONS

Contents

- 25.1 Objectives
- 25.2 Introduction
- 25.3 Maxwell's Equations
- 25.4 Applications
 - a Clausius Clapyion's latent heat equations
 - b Joule-Kelvin's Effect
- 25.5 Summary
- 25.6 Sample Examination Questions

25.1 OBJECTIVES

This unit discusses the Maxwell's thermodynamic equations and its applications.

After going through this unit you will be able to:

- (i) Understand the Maxwell's thermodynamic equations.
- (ii) Explain the applications of these equations

25.2 INTRODUCTION

The main aim of this chapter is to make use of 2 laws of thermodynamics in convenient form and to a set of fundamental relations, known as thermodynamic relations, which find ready application to particular problems. Here the main aim is to deduce these relations & indicate their application to some thermal phenomena.

In general the condition of a substance is completely determined by any pair of the quantities P , V , T & S . In solving therefore any thermodynamic problem, the pair most suitable is chosen as independent variables. Also the applications aspect especially to that of (1) clausius clapyron's latent heat equation & (2) Joule -Kelvin Effect is dealt in this chapter, though there are many other applications. The quantities dealt above as P , V , T & S are pressure, volume, temperature & entropy respectively.

25.3 MAXWELL'S EQUATIONS

Maxwell's Equations can be derived directly from thermodynamic potentials, & also using I law of Thermodynamics.

Which gives $\left(\frac{df}{dq}\right)_T = -P$ and $\left(\frac{df}{dt}\right)_V = -S$

Partially differentiating w.r.v.t and w.λ.v. respectively
We have

$$\frac{d^2f}{dvdt} = \left(\frac{dp}{dt}\right)_v \text{ and } \frac{d^2f}{dt dv} = \left(\frac{ds}{dv}\right)_T$$

Since df is a perfect differential we have $\left(\frac{dp}{dT}\right) = \left(\frac{ds}{dv}\right)$ This is Maxwell's 3rd equation.

IV. Relation: Gibbs' Function $G = U + P_v - Ts$

In terms of basic coordinates

$$dG = Vdp - sdT, \text{ Which gives, } \left(\frac{dg}{dp}\right)_T = V \text{ and } \left(\frac{dg}{dt}\right)_P = -S$$

Differentiating w.r.t.T & differentiating w.r.t.P. respectively, the above equations, we have

$$\frac{d^2G}{dpdT} = \left(\frac{dv}{dT}\right)_p \text{ \& } \frac{d^2G}{dTdp} = \left(\frac{ds}{dp}\right)_T$$

Since dG is a perfect differential $\frac{d^2G}{dpdT} = \frac{d^2G}{dTdp}$

Hence we write

$$\left(\frac{dv}{dT}\right)_p = \left(\frac{ds}{dp}\right)_T \text{ This is Maxwell's 4th equation}$$

These above Maxwell's thermodynamic equations 1, 2, 3 & 4 must hold good for any pure substance.

25.4(a) APPLICATIONS

Clausius Clapyrons Latent Heat equation:

The clausius clapyrons latent heat equation relates the change in melting point or boiling point with change in pressure. We take the Maxwell's third equation, which contains

dp/dT term for the purpose & obtaining this equation

$$\left(\frac{dp}{dT}\right)_v = \left(\frac{ds}{dv}\right)_T \quad \dots (25.3)$$

Multiplying both the sides by T, we have

One essential condition of Joule-Kelvin's expansion of a real gas is that the enthalpy of the gas $h = u + Pv$ must remain constant i.e. $dh = 0$, although there is a pressure difference across the throttling valve or porous plug.

Joule Kelvin's coefficient is defined as the ratio of the temperature of a gas to the change of pressure upon throttling at constant enthalpy & represented by μ

$$\text{Thus } \mu = \left(\frac{dT}{dP} \right)_h$$

The exprn for μ can be achieved i.e. Joule - Kelvin coefficient is terms of the basic thermodynamics coordinates from enthalpy & second T.ds equations.

$$\text{Enthalpy } h = u + Pv \quad (25.5)$$

$$\text{and } dh = Tds + udp$$

Taking the second Tds equation

$$Tds = c_p dT - T \left(\frac{dv}{dT} \right)_p dp \quad (25.6)$$

and substituting the value in equation (25.5) above we get

$$dh = c_p dt - T \left(\frac{dv}{dT} \right)_p dp + Vdp$$

$$= C_p dT - \left[T \left(\frac{dv}{dT} \right)_v - v \right] dp \quad \text{or}$$

$$C_p dT = dh + \left[T \left(\frac{dv}{dT} \right)_v - v \right] dp \quad \text{or}$$

$$\frac{dT}{C_p} = \frac{dh}{C_p} + \left[T \left(\frac{dv}{dT} \right)_v - v \right] \frac{dp}{C_p}$$

$dh = 0$ since enthalpy h is constant

$$\therefore \frac{dT}{C_p} = \frac{1}{C_p} \left[T \left(\frac{dv}{dT} \right)_v - v \right] dp$$

$$\text{But } dT = \left(\frac{dT}{dP} \right)_h dt + dt dp$$

$$\text{so we write } \left(\frac{dT}{dP} \right)_h dt = \frac{1}{C_p} \left[T \left(\frac{dv}{dT} \right)_v - v \right] dt$$

$$\mu = \left(\frac{dT}{dP} \right)_h \quad \text{we have}$$

Dr.B.R.AMBEDKAR OPEN UNIVERSITY
(under graduate programme)
SECOND YEAR SYLLABUS
PHYSICS – COURSE – 2.
ELECTROMAGNETISM AND THERMODYNAMICS

BLOCK – 1 : VECTORS AND ELECTROSTATICS

- Unit –1 : Vectors
- Unit –2 : Electric fields and Gauss Theorem
- Unit –3 : Electric Potential
- Unit –4 : Capacitance
- Unit –5 : Parallel plate condenser with and without dielectric

BLOCK – 2 : CURRENT DENSITY, STEADY CURRENTS AND CIRCUITS

- Unit –6 : Electrical Conductivity
- Unit –7 : Kirchoff's Laws
- Unit –8 : Networks

BLOCK – 3 : MAGNETOSTATICS

- Unit –9 : Ampere's Law
- Unit –10 : Biot-Savart's law
- Unit –11 : Magnetic force on a circuit, Torque

BLOCK – 4 : ELECTROMAGNETIC INDUCTION

- Unit –12 : Motion of charged particle
- Unit –13 : Determination of isotopic masses
- Unit –14 : Self inductance and mutual inductance
- Unit –15 : Faraday's laws of Induction
- Unit –16 : Magnetic Energy – Maxwell's Equations

BLOCK – 5 : VARYING CURRENTS

- Unit –17 : LR, LC and CR circuits with A.C
- Unit –18 : Transient Response
- Unit –19 : Series and parallel resonance circuit

BLOCK – 6 : LAWS OF THERMODYNAMICS

- Unit –20 : Zeroth and first law of thermodynamics
- Unit –21 : Reversible and Irreversible processes
- Unit –22 : Carnot's cycle and carnot's theorem
- Unit –23 : Second law of thermodynamics and entropy
- Unit –24 : Thermodynamic potentials
- Unit –25 : Maxwell's thermodynamic equations and applications.

FACULTY OF SCIENCE
SECOND YEAR (3 YEAR DEGREE COURSE) EXAMINATION
MODEL QUESTION PAPER

COURSE II: ELECTROMAGNETISM & THERMODYNAMICS

Time: 3 Hours

Max Marks:70
Min Marks: 25

SECTION – A
(Marks: 3X15=45)

Instructions to the candidates:

- 1) Answer any three of the following questions in about 30 lines each
- 2) Each question carries fifteen marks

- 1) Define electric potential and field strength. Give the expression for potential due to a point charge.
- 2) Explain electric displacement. Applying Gauss theorem find the intensity of the field of uniformly charged sphere.
- 3) Derive an expression for energy stored in the field of a charged condenser.
- 4) State Kirchoff's laws. Applying these laws, calculate the potential difference and current in a multiple loop circuit.
- 5) Describe Thomson's method of experiment for determining e/m of an electron.
- 6) Derive differential relations for thermodynamic potentials.

SECTION-B
(Marks: 5x5=25)

Instructions to the candidates:

- 1) Answer any five of the following questions in about 10 lines each.
- 2) Each question carries five marks.
- 7) Explain zeroth law of thermodynamics.
- 8) Calculate the efficiency of a steam engine operating at 10 atmosphere at which pressure, water boils at 180°C the temperature of the condenser is 30°C .
- 9) Write short notes on parallel L C R circuit.