

ZOOLOGY

Non-Chordata & Protochordata

BLOCK I - Non-Chordata

BLOCK II - Protochordata

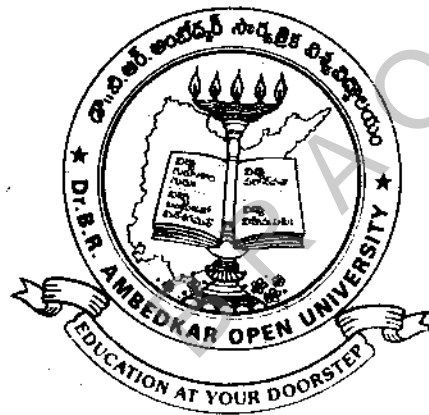

Dr. B.R. AMBEDKAR OPEN UNIVERSITY
Hyderabad
1992-93

COURSE TEAM

21496
1-12-93

Editor

Dr. V. Jagannadha Rao

Associate Editor

Dr. Girija Neti

Writers

Dr. V. Lakshmi pathi

Dr. K. Bhaskar Reddy

Dr. A.R. Verma

Dr. Mrs. Kusuma K. Murthy

Dr. T. Ratnamala Rao

**Dr. BRAOU
LIBRARY**

Cover Design

Chandra

Graphics

M. Ramesh

Dr. B.R.A.O.U. LIBRARY	
Acc.	21496
Date	1-12-93
Call No	200

Dr. B.R. AMBEDKAR OPEN UNIVERSITY

Hyderabad

First Published in 1984 © Copy right 1989 Dr. B.R.A. Open University

Second revised edition, 1990

Reprint 1992-93

All rights reserved. No part of this book may be reproduced in any form without permission in writing from the University.

This text forms part of Dr. B.R.A. Open University Course. The complete syllabus for the Course appears at the end of the text.

Further information about the Dr. B.R.A. Open University Courses may be obtained from the Director (Academic) Dr. B.R.A. Open University, Hyderabad (A.P.)

Printed at Siva Graphics & Printers, 494/2RT, S.R. Nagar, Hyderabad for Dr. B.R.A.O.U.

PREFACE

This book deals with the topics in Non-Chordata and Protochordata included in the syllabus for the second year of Zoology course offered by the Andhra Pradesh Open University. These topics generally cover the 'Core' area of the subject to be studied in the Second Year of the three year Degree Course in Science (B.Sc.). The syllabus for the sake of convenience is divided into two blocks, each of which comprises of a number of units. Each block generally covers a specific area of the subject. The units are prepared by specialists in accordance with the format so designed as to enable the student to read and understand them without much difficulty. Each unit begins with a statement of its objectives followed by introduction and has at its end synopsis and also check your progress' intended to test the students' comprehension of its subject matter. Technical terms with which the student may not generally be familiar are given at the end of each unit under the head 'Glossary'.

The course material of this paper is divided into two blocks. The blocks are in turn divided into 32 units. The first 25 units (Block-I) deal with Non-Chordata and the last seven units (Block-II) are concerned with Protochordata. Unit I deals with the introduction to Animal Kingdom. In unit II general characters and classification of sub kingdom protozoa are given. Life histories of some free living and parasitic forms and protozoan diseases are included in unit III & IV. Unit V deals with characters and classification of phylum porifera. Units VI & VII cover the general characters and classification of cnidaria. Units VIII to XVIII deal with characters, classification of various phyla such as Platyhelminthes, Aschelminthes, Nematodes, Annelida, Mollusca, and Arthropoda etc. Unit XIX discusses general characters and affinities of *Peripatus*. Units XX & XXI deal with beneficial and harmful insects. In units XXII to XXIV development of *Asterias* and importance of echinoderm laeval has been discussed.

In Block-II, units XXVI to XXXII deal with the concepts of coelom, symmetry, cephalization and metamerism, general characters of chordata and Protochordata. Various protochordata types, *Balanoglossus*, *Herdmania* and *Amphioxus* have been discussed.

General accounts of various type animals like *Sycon*, *Obelia*, *Nereis*, *Pila*, *Palaemon* and *Asterias* are described under the respective chapters.

The University hopes that this material will help the students to get acquainted with non-chordates and protochordates and evolutionary trends among non-chordates.

BRAOU

CONTENTS

BLOCK-I

UNIT-1	Introduction to Animal Kingdom	1
UNIT-2	Protozoa - General Characters and Classification	8
UNIT-3	<i>Elphidium, Monocystis</i> and <i>Vorticella</i>	13
UNIT-4	Protozoan diseases	27
UNIT-5	Porifera - General Characters and classification study of <i>Sycon</i> as a type	41
UNIT-6	Cnidaria - General Characters and Classification	54
UNIT-7	<i>Obelia</i>	59
UNIT-8	Platyhelminthes - General characters and classification	67
UNIT-9	Important Trematode and Cestode parasites	72
UNIT-10	Ascheimnthes - General characters and classification	83
UNIT-11	Important Nematode parasites	88
UNIT-12	Annelida - General characters and classification	96
UNIT-13	<i>Nereis</i>	102
UNIT-14	Mollusca - General characters and classification	113
UNIT-15	<i>Pila globosa</i>	120
UNIT-16	Economic importance of Mollusca	130
UNIT-17	Arthropoda	137
UNIT-18	<i>Palaemon</i> (Fresh water prawn)	147
UNIT-19	General characters and affinities of Onychophora	160
UNIT-20	Beneficial insects	166
UNIT-21	Harmful insects	173
UNIT-22	Echinodermata - General Characters and classification	181
UNIT-23	<i>Asterias</i>	187
UNIT-24	Echinoderm larvae	195
UNIT-25	Evolutionary trends in invertebrates	202

BLOCK-II

UNIT-26	Protochordates - General characters, classification and affinities of subphylum Hemichordata	208
UNIT-27	<i>Balanoglossus</i>	214
UNIT-28	Subphylum - Urochordata - General Characters and Classification	221
UNIT-29	<i>Herdmania</i>	226
UNIT-30	Development of <i>Herdmania</i> and affinities of Urochordatas	239
UNIT-31	Subphylum Cephalochordata <i>Amphioxus</i>	245
UNIT-32	Affinities of <i>Amphioxus</i>	257

Glossary

Suggested Reading Syllabus of second year (Course I)

BRAOU

BLOCK - I
NON-CHORDATA

BRAOU

BRAOU

UNIT — INTRODUCTION TO ANIMAL KINGDOM

Contents

- 1.1 Objectives
- 1.2 Introduction
- 1.3 Historical Account of Zoology
- 1.4 Different Branches of Zoology
 - 1.4.1 some common terms
- 1.5 Methods of Study
- 1.6 Purpose of Study
- 1.7 Animal Numbers
- 1.8 Some Major Aspects of the Classification of the Animal Kingdom
 - 1.8.1 Taxonomy
 - 1.8.2 Taxonomic hierarchy
 - 1.8.3 Binomial nomenclature
- 1.9 An Outline Classification of the Animal Kingdom
- 1.10 Summary
- 1.11 Check Your Progress-Model Answers
- 1.12 Model Examination Questions
- 1.13 Glossary

1.1 OBJECTIVES

This Unit is about what Zoology is, its importance, its history and its various branches. It also gives the Principles of animal classification and systematics.

By the end of this Unit you will have

- known historical account of Zoology
- methods and purpose of study
- acquire an overall understanding of the classification and nomenclature of animals.

1.2 INTRODUCTION

Animal life made its appearance on the surface of the earth some millions of years ago and since then a continuous chain of evolution has been going on. The changes came over gradually from the unicellular, simple, disorganised animals to the multicellular, complex, organised and systematic ones. During this long journey of millions of years countless animals appeared, perished, developed, evolved and changed into new and improved types which are fit to cope with the everchanging environmental conditions. All parts of land, soil, sea and fresh water and the skies are the homes of a variety of animals. The science which deals with the study of animals is called 'Zoology' (Gr. zoon: animal, logos: to study). The science of zoology covers the field of the animal form and function, development and the life cycles, evolution and its factors and the environment.

1.3 HISTORICAL ACCOUNT OF ZOOLOGY

Man's interest in animals dates back to prehistoric era, when man made use of them for food, clothing and he had to kill them for his survival. The old civilizations of Babylon, Egypt and Greece had some knowledge of animals. The Greeks were the pioneers in zoology. Scientists like Anaximander (611-547 B.C.), Zenophanes (6th Century B.C.), Empedocles (5th century B.C.), and Hippocrates (460-370 B.C.) contributed substantially. But the man who is called 'The Father

of Zoology' was the great Greek scientist Aristotle (384-322 B.C.). He not only carried out extensive work on the plants, reproduction of animals, development of the chick but also wrote nine volumes on animal structure and habits entitled 'Histoma animalium'. The Romans were the next to make significant contribution to different aspects of this fascinating, subject. The importance of the work of the Greeks and the Romans was so great that most of the terms in vogue now have their origin either from the Greek or the Latin language.

After the Renaissance in Europe along with the dawn of Science, Zoology attracted many great souls. William Harvey, Robert Hooke, Leeuwenhoek, Linnaeus, Schleiden, Schwann, Bernard, Darwin, Wallace, Pasteur, Mendel, Krogh and Hyman are a few giants of Zoology who have made indelible impressions on the History of Zoology by their discoveries, theories, laws and inference.

1.4 DIFFERENT BRANCHES OF ZOOLOGY

Different aspects of zoology are studied under different sub-divisions. The major branches of zoology have been listed below:

1. **Morphology** (Gr. Morphe: form; logos, to study):- The study of the external structure.
2. **Anatomy** Gr. ana: up; tomn: cut):- The study of the internal structure by means of dissection.
3. **Histology** (Gr. histos: tissue):- The study of the microscopic structure of tissue.
4. **Cytology** (Gr. kytos: hollow):- The study of structures and functions within cells.
5. **Physiology** (Gr. physid: nature):- The study of the functions of organs and systems.
6. **Taxonomy** (Gr. taxis arrangement; nomos: law):- The study of classification.
7. **Ecology** (Gr. oikos: house):- The study of the relationship between the animals and their environment.
8. **Embryology** (Gr. en: in; bryo: swell):- The study of growth and development of an individual within the egg.
9. **Zoogeography** (Gr. zoon: animal; ge: earth; graphein: to write):- The study of the distribution of animals.
10. **Pathology** (Gr. phatos: suffering):- The study of the nature, symptoms and causes of disease.
11. **Evolution** (L.e: out; volvo: roll): The study of the origin and differentiation of animal life.
12. **Palaeontology** (Gr. palaois: ancient; ont: being):- The study of past life by means of fossils or animal remains.
13. **Genetics** (Gr. genesis: origin):- The study of transmission of characters from parent to offspring.
14. **Parasitology** (Gr. para: beside; sitos: food):- The study of parasites.
15. **Osteology**:- The science of the study of bones.
16. **Endocrinology** (Gr. endon: within; krinein: to separate):- The study of ductless glands and their secretions, the hormones.

In addition to the above mentioned main branches of zoology there are some special branches which have been mentioned below:

1. **Protozoology** (Gr. protos: first; zoon: animal):- The study of one-celled animals, the Protozoa.
2. **Helminthology** (Gr. helmins: worm):- The study of parasitic worms.
3. **Phyto-nematology** (Gr. phyton: plant; nema: thread):- The study of plant-nematodes.
4. **Entomology** (Gr. entomon: insect):- The study of insects.
5. **Ichthyology** (Gr. ichthys: fish):- The study of fishes.
6. **Herpetology** (Gr. herpoin: to creep):- The study of amphibians and reptiles.
7. **Ornithology** (Gr. Ornis: bird):- The study of birds.
8. **Mammology** (Gr. mamma: breast):- The study of Mammals.
9. **Apiculture**:- The cultivation of honey bees.

10. **Sericulture:-** The cultivation of silk worms.

11. **Pisciculture:-** The cultivation of fishes.

12. **Poultry:-** The cultivation of fowls.

1.4.1 Some common term

While studying structures and functions of an animal we come across different terms which pertain to one or the other parts of the body. To make such terms easily understandable a list of such terms and words is given below:

1. Cutaneous	relates to skin
2. Cerebral	relates to brain
3. Visceral	pertains to viscera
4. Gastric	pertains to stomach
5. Hepatic	relates to liver
6. Renal	refers to kidney
7. Gonadial	refers to reproductive organs
8. pulmonary	relates to lungs
9. Cardiac	refers to heart
10. Neural	refers to nerves
11. Skeletal or Artho or astro	pertains to bones

1.5 METHODS OF STUDY

Zoological studies can be made in many ways. Living animals are studied in their original natural environments whereas other kinds of studies are possible in the laboratories in captivity or in reared conditions; yet some studies can be made in museums where the animals are kept in preserved and stuffed conditions. The specimens are preserved in formaldehyde or alcohol (fishes, reptiles, amphibians etc., and invertebrates) or mounted slides (microscopic animals) or dried (insects, stuffed birds and mammals, and molluscs etc.) These preserved specimens help a lot in identification, classification, anatomical studies and other related purposes. Professional naturalists collect and preserve the specimens and publish the results and data of their observations and thus contribute to the advancement of zoology.

1.6 PURPOSE OF STUDY

There are several purposes of studying zoology which are listed below.

1. An all round education would be incomplete without the knowledge of animals and of the basic principles of biology.
2. It is a source of personal satisfaction, some find pleasure in learning about animals and for some it is hobby and they develop special interest and bird-watching, shell collection, fish rearing and so on.
3. It can lead to ways of making a living and in some case it is financially rewarding.
4. A knowledge of animals of practical importance to mankind is essential in this advancing age. It is an integral part of understanding the basis of one's own life.
5. It is also an integral part of the cultural education of modern society.
6. It is medically useful. For people in medical, biomedical and para - medical fields, is of positive scientific and social value, so also to people in agriculture, fisheries, public health, food processing and biochemistry etc, it is equally useful.

1.7 ANIMAL NUMBERS

Over 1,250,000 types of animals or species are known today and many more remain to be discovered. However, estimates of their number are not completely correct, they are only

approximate. Of these five percent are chordates, animals with a vertebral column or backbone; and the rest are invertebrates. Among the invertebrates arthropods are the most abundant, which are followed by molluscs.

1.8 SOME MAJOR ASPECTS OF THE CLASSIFICATION OF THE ANIMAL KINGDOM

The classification of the animal kingdom is based on certain principles and guided by a formal code of rules. Some 5000 years ago people classified the animals on the basis of similarities. As the science of taxonomy advanced and various branches of zoology progressed, classification was based on morphology, embryology, life histories, behaviour and physiology. They formed the important and basic sources of classification. After the advent of genetics, molecular biology, biochemistry, serology and allied sciences, these also constituted essential aspects of classification.

1.8.1 Taxonomy

According to Simpson 'taxonomy' is the theoretical study of classification, including its bases, principles and rule. It was first proposed by de Candolle in 1813 for the theory of plant classification. Later on it was accepted for zoological classification also.

Taxonomy has two aspects. They are *classification* and *nomenclature*.

Classification: It is the orderly grouping of animals into groups or sets on the basis of their relationships.

Nomenclature: It is the application of distinctive names to each of the groups recognised in classification.

Taxonomy, classification, and nomenclature are included in broader field called systematics. This has been defined as the scientific study of the kinds and diversity organisms and of relationships among them.

1.8.2 Taxonomic hierarchy

All major groups of animals can individually be sub-divided into smaller and smaller sub-groups. To facilitate the position of an individual animal it has been arranged in categories and taxa of different grades.

Carolus Linnaeus (1707-1778), who was the first great taxonomist recognised only five categories. They are class, order, genus, species and varieties. But in the course of time it has modified and the following categories are accepted. Kingdom, Phylum, Class, Order, Family, Genus and Species.

Taxa	Man	Dog	Frog	Cockroach
Kingdom	Animalia	Animalia	Animalia	Animalia
Sub-kingdom	Metazoa	Metazoa	Metazoa	Metazoa
Phylum	Chordata	Chordata	Chordata	Arthropoda
Class	Mammalia	Mammalia	Amphibia	Insecta
Order	Primates	Carnivora	Anura	Dictyoptera
Family	Hominidae	Canidae	Ranidae	Blattidae
Genus	Homo	Canis	Rana	Peripatus
Species	<i>sapiens</i>	<i>familiaris</i>	<i>tigrina</i>	<i>americana</i>

All the animals apart from their common names, are known by their scientific names. This is a universal method which was developed and practised by taxonomists. Each kind of animal has a scientific name, irrespective of its distribution on the surface of earth and it is used all over the world.

Before we go any further it is better if we define the terms genus and species, as they will be frequently used in our animal descriptions.

Genus: It is a group of organisms consisting of a number of species closely resembling one another. The term genera was coined by English naturalist, **John Ray** (1627-1705).

Species:- The species is the basic unit of taxonomic classification of all animals and plants. It is the most important category in the taxonomic hierarchy. Definition of 'Species' has long been one of the main problems of taxonomy, as its definition has been changed from time to time. A simple definition of species may be that they are the group of animals which always breed true, in the sense that they never produce individuals other than, their own. Species have also been defined as a population of interbreeding individuals by Mayr in 1942.

There are various concepts of species available in taxonomic literature. Some old concepts have given way to modern ideas. The biological species concept was first clearly worked out by K. Jonan in 1905. The main characters of animal species are summed up below:

1. **An interbreeding community:-** Species is a reproductive community, i.e., the individual of a species of animals recognise each other as potential mates for the purpose of reproduction.
 2. **An ecological unit:-** Species is also an ecological or environmental unit. It fills an ecological niche not exactly used by another species.
 3. **A genetic unit:-** Each species consists of a common gene pool with a free gene flow.
- The above mentioned factors gave rise to the present, 'species concept' viz., "species are groups of interbreeding natural populations that are reproductively isolated from such groups".

1.8.3 Binomial nomenclature

Although the history of taxonomy dates back to the fifth and the sixth centuries B.C. Aristotle made an attempt to evolve a system of classification. Since then many taxonomists and biologists made significant contributions towards this science.

Before Linnaeus, no definite system of naming the animals was in practice. They were known by their common names in different languages. Linnaeus succeeded in assigning to every known animal and plant a systematic position. The great work done by him is found in his 'Systema Naturae' in the tenth edition which was published in 1758, in which he used Latin or Latinised words for each animal. His work made history in the biological world and is now followed all over the world.

The use of double Latin name to describe every species is known as the 'binomial nomenclature'. Of these the first indicates its 'genus' and the second denotes its 'species'.

To quote an example, which was illustrated by Linnaeus himself, known as *Homo sapiens*, "Man the reasoner". But in the genus *Homo*, another species the orangoutang is included. This creature is designed as *Homo troglodytes*, "Man the cave-dweller". Similarly, *Equus* is the generic name of the horse and similar ones. But *Equus caballus* is the wild horse, *Equus asinus* is the wild ass, and *Equus zebra* is the zebra.

Before Linnaeus, another Swiss, **Karper Bauhin** (1560-1624) and **Andrea Casalpino** (1519-1603), Professor at Pisa, had distinguished clearly between the idea of a genus and of a species of plants. **Bauhin** described about six thousand species of plants, and he was the first of the systematists. In fact the tradition was carried on by other taxonomists like **Joachin Jung**, a German; Englishman, **John Ray**; and **Tournefort** of France, down to Linnaeus.

To every known species of animal and plant, naturalists now attach a scientific name. This name is always in Latin and is always double. The genus group name must be a noun in the nominative singular and its first letter is always capital, such as *Amoeba* or *Rana*. While the species name may be simple or compound and is usually an adjective, agreeing in gender with the generic name; e.g. *esculanta* or a noun in the nominative singular, e.g. *Rana tigrina*.

1.9 AN OUTLINE CLASSIFICATION OF THE ANIMAL KINGDOM

The present classification of the animal kingdom is advocated by Hyman (1940).

The animal kingdom is divided into two major groups — The sub Kingdoms, Protozoa and

Metazoa. The basic difference is that the former one is unicellular or acellular and the latter is multicellular. Moreover, the acellular protozoans and multicellular metazoans occupy very different sets of ecological niches.

Protozoa-acellular or unicellular — Very often protozoans have been called both as acellular and unicellular animals. The latter is the original definition. There are two concepts about the nature of protozoa.

The first theory regarded protozoa as unicellular and that the protozoans morphologically resemble a single cell of metazoan body. It also suggested that the Metazoa arose by aggregation of separate protozoan individuals. The second theory opines that a single protozoan performs all the life activities and physiological processes of a metazoan, and as such a protozoan single cell is not a part of a Metazoa, but it is equivalent to the whole metazoan organisation. It can be inferred that according to this theory the protozoa should be considered as acellular in nature. Because of this unique character the Protozoa has been given a special status of a sub kingdom. There is also a trend to elevate it into an individual kingdom — **Protista**.

A brief classification of the animal kingdom is given below:

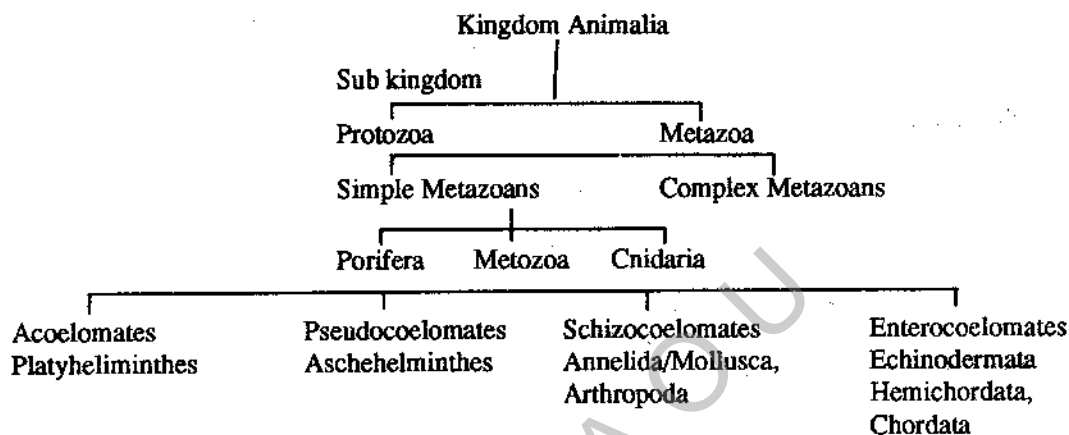

Check your progress

- To describe a species the usage of double Latin names is called as which indicate the and the of the animal.

1.10 SUMMARY

Zoology is the science of animals. The history of zoology covers about 2000 years. Greek, Roman and European scientists contributed to its development. There are several branches of zoology dealing with different aspects of animal life form, functions, development, etc. The study of zoology is necessary to understand the fascinating animal world. It is also rewarding. It is useful socially and medically. The animal kingdom is divided into 2 main groups unicellular and multicellular. Unicellular group has only one branch, protozoa. Multicellular group is further divided according to the cellular organisation into many including vertebrates.

1.11 CHECK YOUR PROGRESS — MODEL ANSWERS

- binomial nomenclature
species genus

1.12 MODEL EXAMINATION QUESTIONS

- Answer the following in about 30 lines.
 - What is Zoology? Write down its brief history and objectives?

II. Answer the following in about 10 lines.

1. Give an account of different branches of Zoology.
2. With suitable examples, describe the contribution made by Linnaeus.
3. Give an outline classification of the animal kingdom.

1.13 GLOSSARY

Acoelomates	: (GK. a without: Kiolos howflow) Animals having no coelom or body cavity.
Behaviour	: The way an animal acts and reacts to various needs in various situations.
Biochemistry	: The chemistry of life.
Biology	: (GK Bios: life; logos; to deal) The science of living things.
Cell	: (L: Cell: Compartment) The structural unit of all living things.
Compound eye	: An eye made up of several lenses.
Diagnostic	: Differentiating, distinguishing.
Dissection	: To cut open to display parts.
Diversity	: State of difference, unlikeness and variety.
Double life	: Leading life both on the land and in the water.
Endoparasite	: An organism living within its host.
Evolution	: (L. evolvere: to unroll) The gradual change of animals and plants from one generation to another, leading to new species and varieties etc.
Exoskeleton	: A hard supporting structure on the outer surface of the body.
Gene	: The element which makes up the chromosomes. Biological unit of heredity.
Gill slits	: Openings leading from the pharynx to the exterior in chrodates.
Larva	: An immature, free living stage in the life cycle of various animals.
Life cycle	: A regular succession of various stages undergone by an organism during the course of its existence and finishing with the return to the first stage. Also termed as life history.
Mammary gland	: The milk secreting glands of the mammals.
Molecular biology	: Biology of the smallest particles.
Multicellular	: Organisms which are made up of many cells.
Niche	: The ecological position which best suits a particular organisms.
Notochord	: An elastic skeletal rod running along the back beneath the nervecord in the embryos or adult of chordates.
Organ	: A differentiated part of the organism adopted for a definite function.
Parasite	: An organism that lives and feeds in or on another organism.
Shell	: The hard outer covering of an animal.
System	: Basic functions of the body carried out by the combinations of tissues and organs.
Tissue	: An aggregation of cells.
Unicellular	: Organisms with only one functional cell.
Vertebral column	: The backbone. The most characteristic feature of vertebrates, consisting of a series of small bones or vertebrae, running the length of the body near the dorsal side.
Viviparous	: (L. Vivus: living; parera: to beget) Giving birth to young.

UNIT—2 PROTOZOA — GENERAL CHARACTERS AND CLASSIFICATION

Contents

- 2.1 Objectives
- 2.2 Introduction
- 2.3 General Characters
- 2.4 Classification
- 2.5 Summary
- 2.6 Check Your Progress — Model Answers
- 2.7 Model Examination Questions

2.1 OBJECTIVES

After going through this unit you will be able to:

- List out the important characters of Protozoa.
- describe the classification of Protozoa upto classes.
- List out the important characters of each class with examples.

2.2 INTRODUCTION

Protozoans are the first and the most primitive animal forms to have appeared on the surface of earth. They are the simplest and lowest group of animals. These cellular animalcules were given the name Protozoa in 1822 by Golfuss. The word Protozoa has been derived from the greek language where 'Protos' means first and 'Zoon' means Animal. About 50,000 species of Protozoa are known.

Protozoa are found all over the world. Moisture is necessary for their existence. Majority of Protozoans are solitary and some are colonials. The individuals in a colony are called the zooids and are connected with one another by Protoplasmic connections. A colony develops from a single primary zooid by a process of division.

2.3 GENERAL CHARACTERS

1. These are free-living as well as parasitic. The free living forms are mostly aquatic, found in both marine and fresh waters.
2. Small, usually colourless and microscopic. However, a few forms are coloured and visible to the naked eye.
3. Structure simple, body unicellular or acellular.
4. Solitary or colonial where many similar individuals remain independent.
5. Body symmetry bilateral, spherical or none.
6. All the body functions are performed by the single cell.
7. Body naked or covered by a pellicle or plasmalemma or rigid dead cuticle or calcareous or siliceous shell.
8. Skeleton usually absent but some forms have internal supporting elements like internal shell.
9. Body consists of a mass of protoplasm, differentiated into one or more nuclei and ecto and endoplasam.
10. Cell form usually constant, varied in some, while changing with environment or age in many.
11. The functions of locomotion and feeding are performed by finger-like pseudopodia or whip like flagella or hair like cilia.
12. Nutrition is varied in these animals. It may be holozoic, holophytic, saprophytic, parasitic or mixotrophic. Digestion is intracelular, taking place inside the cell in the food vacuoles.
13. No specific organelles for respiration and excretion. Both the functions are carried out by diffusion through the general outer body surface.

14. Osmoregulation in fresh water forms takes place through contractile vacuole which also serves as an excretory organelle.
15. Reproduction is both asexual and sexual. The former takes place by binary or multiple fission and budding while the latter takes place by conjugation.
16. In many forms life history is marked by alternation of generation.
17. Encystment, formation of resistant cysts-commonly occurs for dispersal and for resisting unfavourable conditions.

2.4 CLASSIFICATION

The conventional classifications of protozoa are based primarily upon modes of locomotion and upon patterns of asexual and sexual reproduction.

Sub-Kingdom and Phylum Protozoa is divided into two sub-phylums:

1. Plasmodroma
2. Ciliophor

Sub-phylum Plasmodroma is divided into four classes while subphylum Ciliophora comprises only one class.

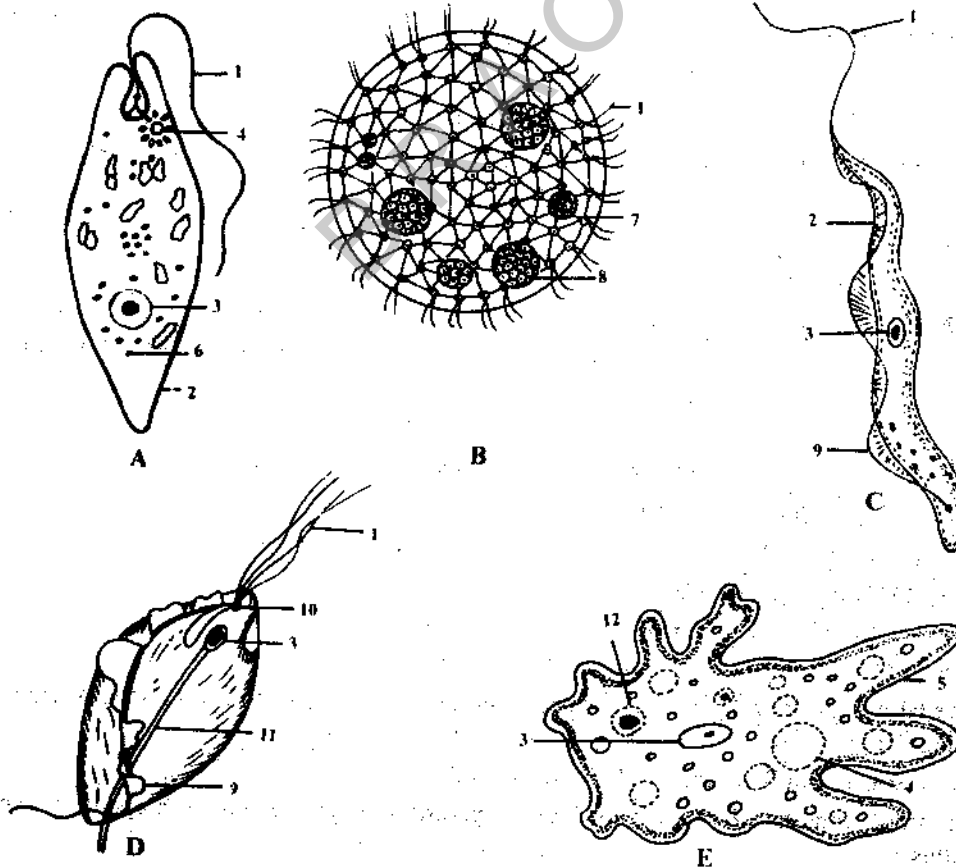
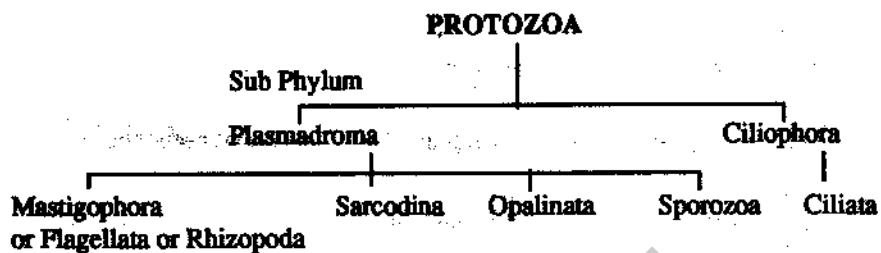

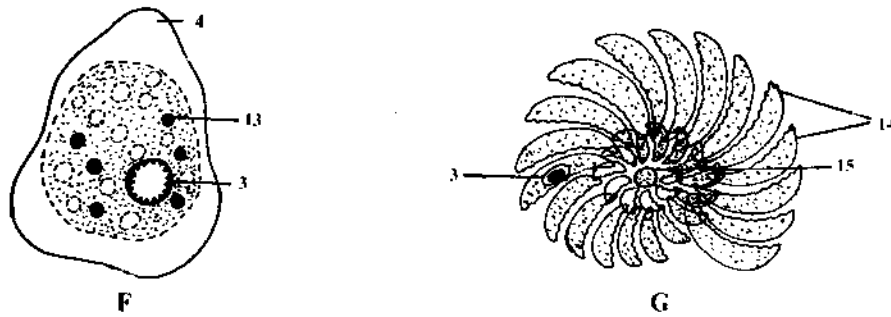

Fig. 2.1 Protozoans. A. *Euglena*. B. *Volvox*. C. *Trypanosoma*. D. *Trichomonas*. E. *Amoeba*. F. *Entamoeba*. G. *Polystomella* (*Elphidium*). 1. Flagellum 2. Pellicle 3. Nucleus 4. contractile vacuole 5. Pseudopodium 6. Paramyllum bodies 7. Somatic cell. 8. Daughter colony 9. Undulating membrane. 10. Blepharoplast 11. Axostyle 12. Food vacuole 13. Ingested R.B.C. 14. Shell chambers 15. Protoplasm.

Class 1: Mastigophora (G. Mastik: Whip; Phoros: bearings) or **Flagellata** (L. Flagrum: A whip)

1. Found in fresh water, sea water and moist soil.
2. Free-living (solitary or colonial) or parasitic.
3. Body with a definite shape and covered by a thin firm pellicle or test made of cellulose or chitin.
4. One or more flagella for locomotion and food capture. With or without pseudopodia.
5. Single nucleus.
6. Nutrition holophytic (autotrophic), holozoic (heterotrophic), saprozoic or mixotrophic.
7. Asexual reproduction occurs in some groups by syngamy. Conjugation is absent. e.g. *Euglena*, *Volvox*, *Trypanosoma*, *Trichomonas*. (Figs. 2.1 A-D).

Class 2: Sarcodina (G. Sarcodes: Fleshy)

1. Found in fresh water, sea water, and moist soil.
2. Mostly free living some are parasites.
3. Body naked, some possess a test or shell around body. Firm pellicle is absent.
4. Pseudopodia for locomotion and food capture. Flagella may be present during some stages of the life-history, but they are not permanent.
5. Mouth absent.
6. Nutrition mostly holozoic.
7. Asexual reproduction by binary fission, multiple fission, spore formation and budding.
8. Sexual reproduction by syngamy. e.g. *Amoeba*, *Entamoeba*, *Polystomella* (Figs. 2.1 E-G).

Class 3: Opalinata

1. Endoparasitic in rectum of cold blooded vertebrates (Frogs and toads).
2. The body is completely and uniformly ciliated.
3. There is no cytostome
4. Nutrition saprozoic (saprophytic).
5. Contractile vacuoles are absent.
6. Nucleus two or more.
7. Asexual reproduction by binary fission, sexual reproduction by gametes. No conjugation e.g. *Opalinata* (Fig. 2.2 A).

Class 4: Sporozoa (G. Spora: Seed; Zoon: animal)

1. The group consists of exclusively internal parasites of vertebrates, arthropods, worms and molluscs.

2. Body covered with a thick pellicle.
3. Locomotive organelles, mouth and vacuoles absent.
4. Nutrition saprozoic, but may also be holozoic.
5. Asexual reproduction by multiple fission.
6. Sexual reproduction by spore-formation and syngamy, where infective stages of the life-cycle, called the sporozoites, are formed.
7. Life cycle shows 'alternation of generations'. e.g. *Monocystis* (Fig. 2.2. B), *Plasmodium*, *Babesia*, *Nosema*, *Sarcocystis* (Fig. 2.2 C).

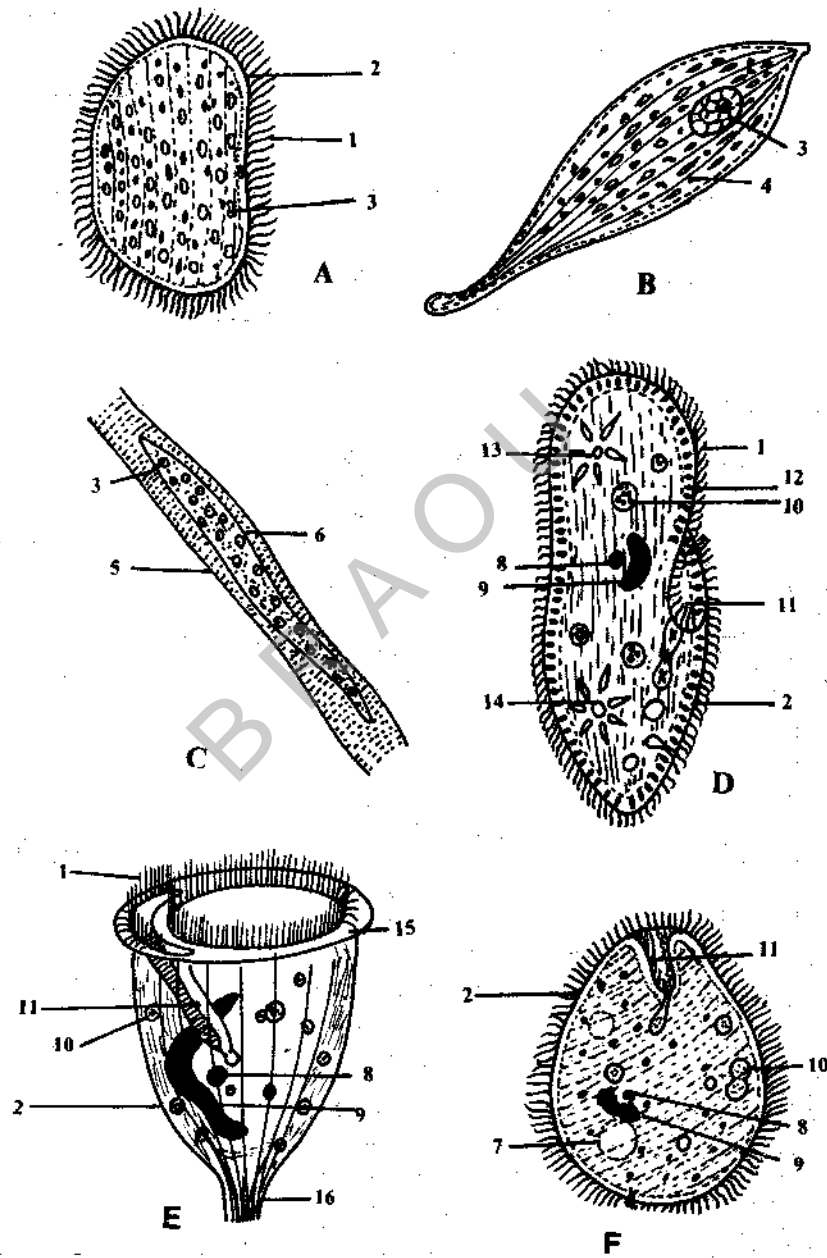

Fig. 2.2. Protozoans. A. *Opalina*. B. *Monocystis*. C. *Sarcocystis*. D. *Paramecium*. E. *Vorticella*. F. *Balantidium*. 1. Cilia. 2. Pellicle. 3. Nucleus. 4. Myoneme. 5. Muscle fibre. 6. Parasite. 7. Contractile vacuole. 8. Micronucleus. 9. Macronucleus. 10. Food vacuole. 11. Vestibule. 12. Trichocyst. 13. Anterior contractile vacuole. 14. Posterior contractile vacuole. 15. Collar. 16. Stalk.

Class — 5: Ciliata

1. Found in fresh water or sea water.
2. Mostly free living (sedentary or colonial) a few are parasitic.
3. The ciliates are the most highly developed protozoans.
4. Body covered by a firm pellicle.
5. Locomotory organelles are cilia, which are also used for food capture.
6. Two types of nuclei are present, showing dimorphism. One large macronucleus governing the vegetative activities and the other small micronucleus controlling sexual reproduction.
7. Mouth and gullet (cytopharynx) present.
8. Nutrition, holozoic.
9. Asexual reproduction by transverse binary fission or budding.
10. Sexual reproduction by conjugation and autogamy. e.g. *Paramecium* (Fig. 2.2 D), *Vorticella* (Fig. 2.2 E), *Balantidium* (Fig. 2.2 F), *Halteria* etc.

Check your progress

- a) The conventional classification of protozoa is based primarily upon modes of.
- b) Mastigophora have one or more _____ for locomotion.
- c) In class _____ the body is completely and uniformly ciliated.
- d) In class _____ pseudopodia are the locomotory organs.

2.5 SUMMARY

Protozoa is the earliest and the simplest of unicellular group of animals. Some are free-living and some parasitic. Single cell performs all the body functions. Protozoa is divided into 5 classes on the basis of locomotory organelles. Mastigophora have flagella. Sarcodina possess pseudopodia; no locomotion in Opalinata and Sporozoa, which are parasitic and cilia are present in ciliates. Physiology simple. Reproduction both asexual and sexual.

2.6 CHECK YOUR PROGRESS — MODEL ANSWERS

- | | |
|---------------|--------------|
| a. locomotion | b. flagella |
| c. opalinata | d. sarcodina |

2.7 MODEL EXAMINATION QUESTIONS

I. Answer the following questions in about 30 lines each.

1. Describe the general characters of Protozoa.
2. Give an outline classification of Protozoa and give brief account of characters of various classes.

II. Answer the following questions in about 10 lines each

1. Differentiate between Plasmodium and ciliophora
2. Describe briefly Locomotory organs of various classes.

UNIT — 3 ELPHIDIUM, MONOCYSTIS AND VORTICELLA

Contents

- 3.1 Objectives
- 3.2 Introduction
- 3.3 Elphidium (Polystomella)
 - 3.3.1 Morphology
 - 3.3.2 Reproduction and life cycle
- 3.4 Monocystis
 - 3.4.1 Morphology
 - 3.4.2 Reproduction and life history
 - 3.4.3 Effect on the host
 - 3.4.4 Alternation of generations
- 3.5 Vorticella
 - 3.5.1 Structure
 - 3.5.2 Physiology
 - 3.5.3 Locomotion
 - 3.5.4 Nutrition
 - 3.5.5 Respiration and excretion
 - 3.5.6 Osmoregulation
 - 3.5.7 Reproduction
- 3.6 Summary
- 3.7 Check Your Progress - Model Answers
- 3.8 Model Examination Questions

3.1 OBJECTIVES

This unit is about the structure, physiology and life cycles of *Elphidium*, *Monocystis* and *verticella*, the three representative types of class sarcodina sporozoa and ciliata respectively. At the end of this unit you will be able to explain the:

- Life history of *elphidium*
- Parasitic nature of *Monocystis* and its effect on the host, earthworm
- Life history of *verticella*, an interesting ciliate and its reproductive methods
 - a. Binary fission
 - b. sporulation
 - c. Conjugation

3.2 INTRODUCTION

Elphidium is a marine protozoan. Free living and found at the bottom due to its weight. It is the most common shelled protozoan which belongs to Foraminiferida (Latin, Forae : Pores, Ferra : to bear) as their shells are perforated by many minute pores.

Monocystis is a parasite of earthworm. It generally inhabits the male reproductive organs, namely testes and seminal vesicles, though occasionally it may occur in the posterior coelomic compartments.

Vorticeella is an interesting ciliate. It presents a highly fascinating look due to periodic coiling and uncoiling of its long stalk during life. *Verticella* companula, like *paramecium* is found in fresh waters all over the world and is quite common in ponds, tanks, lakes, rivers and streams with aquatic vegetation.

3.3 ELPHIDIUM (POLYSTOMELLA)

Phylum	Protozoa
Sub phylum	Plasmodroma
Class	Sarcodina
Order	Foraminiferida
Type	<i>Elphidium</i> (Polystomella)

Elphidium is the most common shelled Protozoan which belongs to order Foraminiferida (Latin, Forare: Pores; Ferra: to bear), as their shells are perforated by many minute pores.

Habitat

Elphidium is a marine form, occurring in all the seas upto a depth of 550 to 600 metres. It is also found in brackish water. It is a bottom dweller.

Habits

It is a free living animalcule. It moves slowly along the sand and the debris at the sea floor.

3.3.1 Morphology

Elphidium is a minute organism visible to the naked eye. Under the microscope it appears like a miniature snail-shell. Its body consists of viscous granular protoplasm. A distinct ectoplasm is lacking. Contractile vacuole is also absent. *Elphidium* shows dimorphism. i.e. it occurs in 2 distinct forms viz., microspheric and megalospheric. These two forms exhibit certain morphological and other dissimilarities, which are listed below.

Microspheric	Megalospheric
1. Less abundant	1. More abundant
2. This form is smaller in size	2. It is larger
3. Multinucleated, the nuclei are small	3. Uninucleated, the single nucleus is a large
4. The initial chamber or proloculum is small	4. The proloculum is large.
5. It reproduces asexually by multiple fission	5. It reproduces sexually by isogamy.

Two important features are characteristic of *Elphidium*. They are shell or test and pseudopodia. (Fig. 3.1)

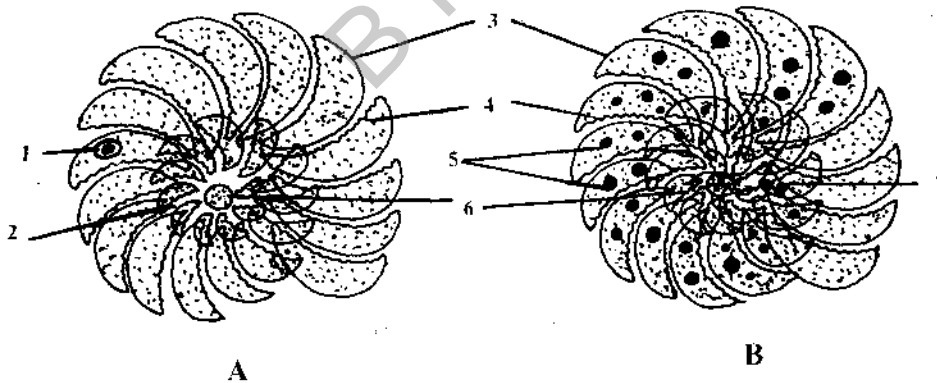

Fig. 3.1. *Elphidium* showing dimorphism. A. Megalospheric form. B. Microspheric form. 1. Nucleus 2. Large Proloculum 3. Outer shell chambers 4. Retral processes 5. Nuclei 6. Proloculum or Initial chamber 7. Small proloculum.

Shell: The shell of *Elphidium* is hard, biconvex and oval or spherical in shape and pale yellow in colour. It surrounds the protoplasm. It is calcareous, and multilocular i.e., many chambered.

Pseudopodia: The pseudopodia of *Elphidium* are long, slender, branching and form a network. They are called myxopodia or reticulopodia. The pseudopodia (reticulopodia) are used for

locomotion as well as capturing the food particles.

No special organelles are present for excretion. Excretory products are diffused through the general body surface. (Fig. 3.2)

3.3.2 Reproduction and Life Cycle

Both asexual and sexual reproduction takes place. Asexual reproduction is marked with multiple fission in the microspheric individual now known as agamont or **schizont**. Sexual reproduction occurs in the megalospheric individual or **gamont**.

Asexual Reproduction

Reproduction which is not carried out by the union of male and female cell. It is the process where only one parent is involved.

As mentioned earlier, the microspheric form exhibits this phenomenon by means of multiple fission or **schizogony**. The entire cytoplasm flows out of the shell and forms a halo around the empty shell. The nuclei break up into chromatin bodies which reorganise to form new nuclei. A bit of cytoplasm surrounds each nucleus forming minute amoeboid cells called amoebulae or 'agametes'. They detach from the parent cell and secrete a shell around to become megalospheric individuals. The first shell becomes the initial chamber or the proloculum of the megalospheric form. As the growth continues, new chambers are added around the initial chamber by the overflowing protoplasm, and the nucleus migrates from one chamber to another and finally it occupies its place in one of the middle chambers of the shell. Now the amoebulae grow into fully formed uninucleated, large, megalospheric adults. In other words the microspheric form gives rise to the megalospheric form by asexual reproduction.

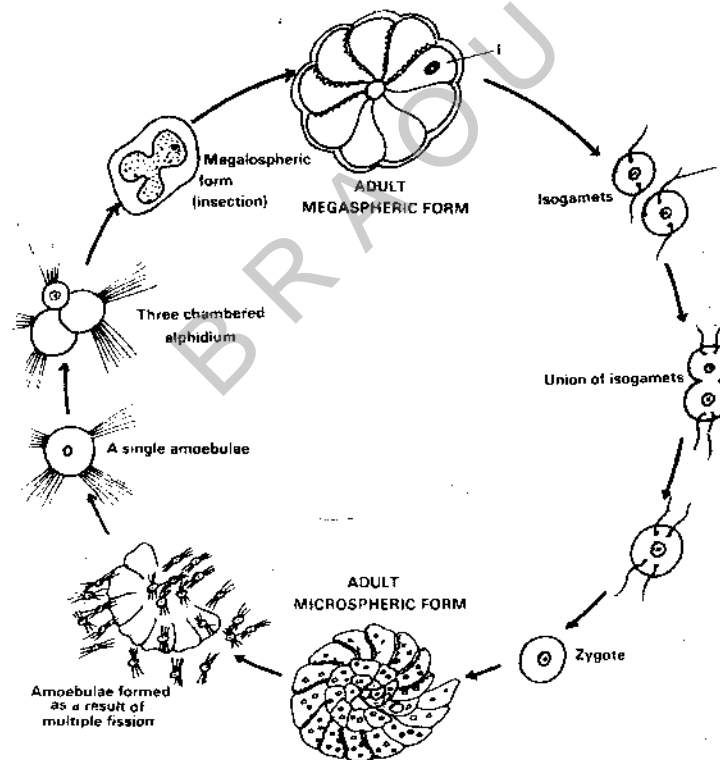

Fig. 3.2 Life cycle of Elphidium. 1. Single nucleus 2. Flagella.

Sexual Reproduction

The megalospheric form reproducing sexually is called a 'gamont'. The nucleus of the gamont divides mitotically into many nuclei. While the cytoplasm also breaks into small fragments. The

D- BRAOU
LIBRARY

Acc. No: 21496
Class No: 541
200

cytoplasmic piece surrounds the nucleus and acquires a pair of flagella. These bodies are called gametes or zoospores or flagellulae. As all the gametes are similar in shape they are termed as isogametes. The isogametes escape into the water through the pores or foramen of the parent shell. They freely swim about in the water with the help of the paired flagella and then become slightly elongated. The haploid gametes from parent cells or megalospheric forms lose flagella and unite or fuse to form diploid zygote. This phenomenon is called 'isogamy'. Each zygote secretes a shell around itself and becomes a young microspheric individual. New chambers are added, nucleus divides into several haploid nuclei and an adult microspheric individual is formed the formation of the microspheric form takes place by the sexual reproduction of the megalospheric or macrospheric form.

Life cycle may be defined as a regular succession of various stages or phases undergone by an organism during the course of its life span and culminating with the return to the first stage or initial stage which is the adult stage.

The life cycle of *Elphidium* exhibits alternation of generations.

1. The microspheric individual represents the asexual generation of Schizont.
2. The macrospheric individual represents the sexual generation of gamont.
3. The microspheric form reproduces asexually and develops into a macropheric form.
4. The macrospheric form reproduces usually to give rise to the microspheric generation which alternates with the sexual macrospheric generation.

The entire life cycle of *Elphidium* is completed in about two years.

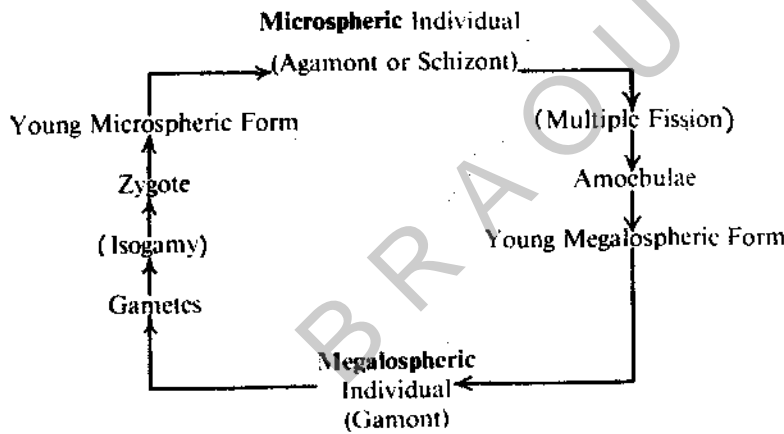

LIFE CYCLE OF ELPHIDIUM

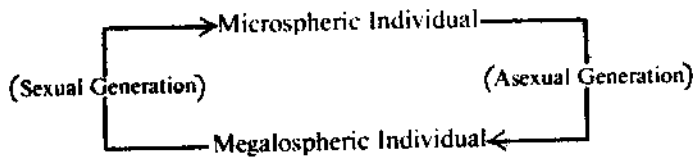

ALTERNATION OF GENERATIONS IN ELPHIDIUM

Check Your Progress - 1

1. *Elphidium* morphologically exhibits

3.4 MONOCYSTIS

Phylum	Protozoa
Sub Phylum	Plasmodromoa
Class	Sporozoa
Sub Class	Telosporidia
Order	Gregarinida
Sub-Order	Eugregarinida
Family	Monocystidae
Genus	<i>Monocystis</i>
Species	<i>Pheritimi</i>

Habitat

Monocystis is an internal parasite of earthworm of the genus *Lumbricus*, inhabiting the male reproductive organs, testis and seminal vesicles. It is wide spread and almost all the earthworms contain them in one or more stages.

Habits

In the young stage *Monocystis* is found as an intracellular parasite in the cytoplasm of the sperm morulae, while as an adult it occurs as an extra cellular parasite in the fluid of the seminal vesicles.

3.4.1 Morphology

The adult stage of *Monocystis* is called the trophozoite, as it is the feeding and growing stage, (Greek, trophe: nourishment).

It is microscopic, minute, worm-like, elongated, or spindle-shaped, fusiform or oval, pointed at both the ends. It measures about 250 to 400 microns in length and 40 to 65 microns in width. Very often the undernourished tiny shrunken sperms of the host are found adhered to the surface of the trophozoite. (Fig. 3.3)

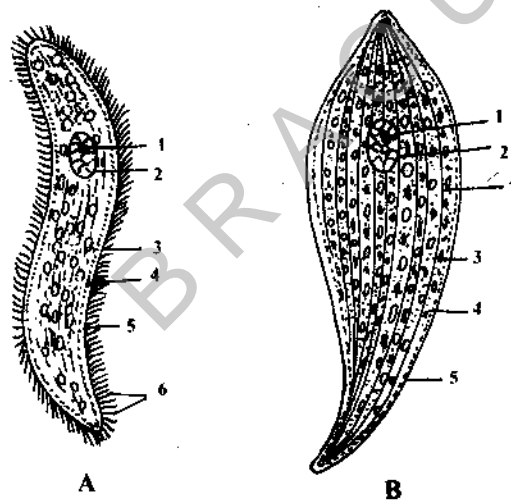

Fig. 3.3. *Monocystis*. A. Free young Trophozoite. B. Mature Trophozoite. 1. Nucleus 2. Endosome 3. Granular cytoplasm 4. Clear cytoplasm 5. Pellicle 6. Sperm tails 7. Myoneme.

The body is covered by a thick firm pellicle called epicyte. The cytoplasm is divisible into an outer thin and dense layer called the ectoplasm or cortex, and an inner dense and granular mass known as endoplasm or medulla.

In the inner layer of ectoplasm are found longitudinal contractile protoplasm fibrils called the myoneme fibrils or myonemes, which have the power of contractivity. These are considered to be the forerunners of the muscular system of higher animals. The endoplasm contains a large vesicular nucleus, and reserve food material in the form of paraglycogen granules, and fat granules or globules.

Locomotory organelles, vacuoles, mouth gullet etc. are totally absent because of its parasitic mode

isogametes arrange themselves to the periphery of the gametocyte, giving a mulberry shape to the gamont.

c) Isogamy or syngamy or conjugation

The partition between the two gametes gets dissolved and the isogametes move to and fro gamonts pair or fuse. The fusion of the gametes is complete, and is called **isosyngamy**, resulting in the formation of large, nucleated, **diploid zygotes or sporonts or sporoblasts**.

d) Sporogony

The developing zygote or sporoblast becomes oval in shape and secretes a rigid, tough resistant chitinioid covering, the **sporocyst or spore-case**. The zygote with the sporocyst is termed as **spore or oocyst**. It assume the shape of a boat or canoe, resembling a diatom, *Navicella*, with a plug at each end. Because of its boat-like appearance it is called a **pseudonavicella**. (Greek, Pseudo: False; Navum: Boat) Altogether 64 pseudonavicellae are found in one gametocyst. The zygote (*Pseudonavicella*) undergoes 3 successive divisions or **multiple fission or sporogony**, the last division being a **reduction division**. It results in the formation of eight haploid uninucleated slender, sickle shaped or fusiform bodies called the **sporozoites or falciform young**. These mark the infective stage of the life cycle of the *Monocystis*. Original gametocyte ruptures and the pseudo navicellae, each containing sporozoites, are released into the cavity of the seminal vesicle of the host earthworm.

e) Transference

Further development is possible only when the spores are transferred to the body of another earthworm, although it may already contain the parasite.

The exact nature of the transfer of the spores from one earthworm to the other is not known. It may probably take place in the following ways:

- i) **During copulation:** It is probable that the spores are shed with the sperms during copulation. The spores have often been observed in the cocoons and the reproductive ducts of earthworms.
- ii) **After the death of the host:** If the host dies, the spores are released in the soil. If such an infected soil is ingested by other earthworms, the spores make their entry into the alimentary canal where the cyst is dissolved and the sporozoites enter the seminal vesicles.
- iii) **By birds:** It is also suggested that the parasite is transferred through birds, when the later eats away an infected worm. The spores pass out along with the excreta of the birds, which is ingested by other earthworms.

3.4.3 Effect on the host

Monocystis thrives on the seminal fluid and the developing sperms. Although a large number of sperms is destroyed by *Monocystis*, the fertility of the host is not affected as very large number of sperms are produced.

3.4.4 Alternation of generations

The live cycle of *Monocystis* shows clear **alternation of generations**. Both the reproductive phases, the sexual and the asexual are met in the life cycle and each alternates with the other.

1. The gametocytes reproduce sexually by syngamy.
2. While a zygote or the sporoblast reproduces asexually by multiple fission.
3. The gametocytes represent the sexual generation.
4. The zygote represents asexual generation.
5. The sexual generation develops into asexual generation and the asexual generation gives rise to the sexual phase by means of sporozoites.
6. These two generations alternate with each other, exhibiting the phenomenon of **alternation of generations**.

LIFE CYCLE OF MONOCYSTIS

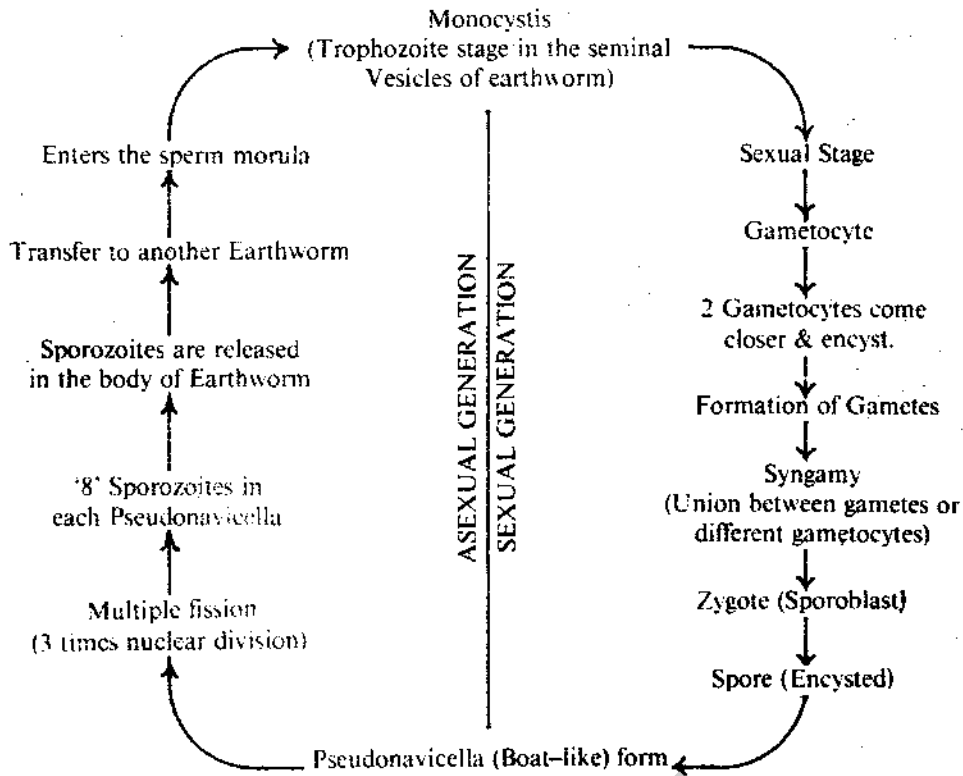

ALTERNATION OF GENERATIONS IN MONOCYSTIS

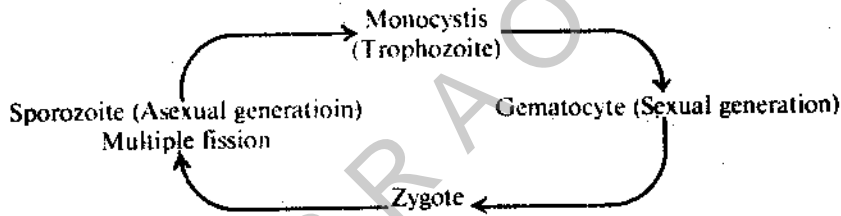

Check Your Progress 2

1. *Monocystis* is an internal parasite ofinhibiting the.....

3.5 VORTICELLA

Phylum	Protozoa
Sub Phylum	Ciliophora
Class	Ciliata
Sub Class	Peritricha
Order	Peritrichida
Sub Order	Sessilina
Family	Vorticellidae
Genus	Vorticella

Vorticella was first described in 1677 (Lain, Vortex: Whirlpool).

Habitat

Vorticella is a fresh water ciliate found in ponds, lakes, rivers and streams.

Habits

It is a free-living sessile or sedentary or fixed solitary form. Many individuals are found in large groups adhered to or fastened to weeds, animals, stones etc., by along slender contractile stalk or pedicel.

3.5.1 Structure (Fig. 3.5)

Shape and size: *Vorticella* is commonly known as bell animalcule as it resembles an inverted bell. A long contractile stalk starts from the base of the bell. It is colourless but it may appear yellowish or greenish in colour. The size of the body or bell measures upto 157 micron in length and 100 micron width, and that of the stalk varies from 50 to 150 micron in length.

Body or bell: It is the main part of the organism. It is like an inverted bell, and is covered by a thick firm **pellicle**. The cytoplasm is divisible into a thin outer **ectoplasm** or **cortex**, and a thick, large granular mass, the **endoplasm** or **medulla**. In the ectoplasm are found five contractile fibrils called the **myonemes**. They converge towards the base of the bell and extend into the stalk as the **axial fibre**. The myonemes shorten the body and close the anterior disc of the bell. The endoplasm contains nuclei, contractile vacuoles and food vacuoles.

Nuclei: *Vorticella* shows nuclear dimorphism. There are two nuclei; a small, spherical **micronucleus** and a large horse shoe-shaped **macronucleus**, or **meganucleus**. Such a condition of double nucleus is called 'heterokaryotic' condition. The micronucleus lies behind the macronucleus, and controls the sexual reproduction. The meganeucleus is only vegetative in function and does not participate actively during the sexual reproduction.

Vacuoles: They are two types contractile and food vacuoles. The contractile vacuole is osmoregulatory in function. It has a reservoir in which the wastes are poured from where they are sent to the vestibule through a narrow duct, a different canal. There may be two contractile vacuoles in some species. There may be several spherical food vacuoles.

Peristome: It is the broad free end of the bell. It is covered by a circular, slightly bulging lid called the **peristomial disc**, or oral disc or epistome. The outer marginal edge of the disc is produced into a prominent rim known as **collar** or **peristomial lip**. Between the collar and the bulged peristomial

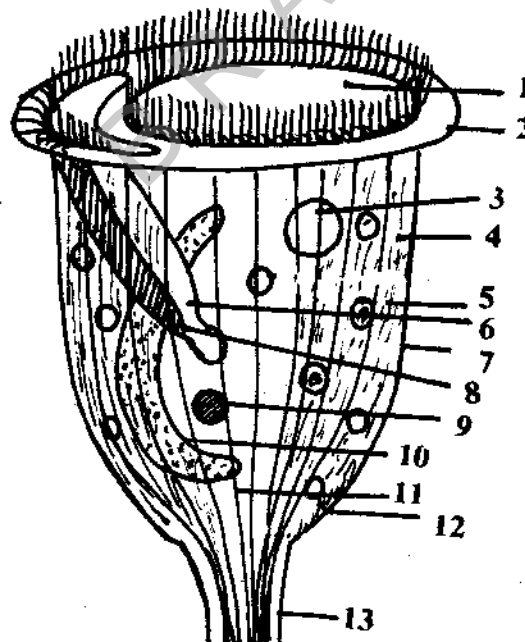

Fig. 3.5 *Vorticella*. 1. Peristomial groove 2. Collar 3. Contractile Vacuole 4. Ectoplasm 5. Endoplasm 6. Vestibule 7. Pellicle 8. Undulating membrane 9. Micronucleus 10. Macronucleus 11. Myoneme 12. Food vacuole 13. Stalk.

disc runs all round a shallow peristomial groove or oral groove. The disc sometimes is withdrawn into the body and the collar encloses the bell from above.

Vestibule: It is a deep funnel-like pit found between the peristome and the disc. It is also called the buccal cavity or **infundibulum**. It leads through cytosome or cell mouth into a delicate narrow **cytopharynx** or cell gullet. It ends blindly into the endoplasm.

Cytoproct: It is a temporary or permanent opening lying near the reservoir through which the undigested food material is passed into the vestibule. It can also be referred to as the cell anus.

Cilia: Body cilia are absent i.e. the bell and the stalk devoid of cilia. Cilia are confined to the peristome and the vestibule. They are called oral or aboral cilia and they are arranged in a whirlpool manner in an anticlock-wise direction about one and half times and then pass down into the vestibule. The peristomial cilia are found at their bases and free distally. When the circlets of the cilia reach the vestibule, the two inner circlets separate from the outer one and descend into the vestibule. The cilia of the outer become long and fuse together to form an undulating membrane. Cilia are absent in the cytopharynx. Cilia of *Vorticella* are the main food capturing organelles. The beatings of the cilia and the cavity of the undulating membrane push the food particles into the vestibule and then down into the cytopharynx.

The bell or body is attached to the substratum through along contractile flexible stalk, which contracts at the slightest disturbance of the water. It consists of an outer sheath or wall and a central canal of endoplasm. The myonemes of the stalk aggregate to form a single thick, spiral bundles called *axial fibre* or *axial filament* or *spasmoneme*, running down at the centre of the ectoplasm. Thus the stalk consists of an ectoplasm, covered by the pellicle and a central axial filament.

3.5.2 Physiology

Physiology in *Vorticella* is advanced and developed than the earlier described protozoan types. Although the single cell is responsible for all the activities, various contents of the endoplasm and parts of the cell body carry out different functions.

3.5.3 Locomotion

Vorticella is a sedentary form and does not move freely from place to place. However, with the hold of the contractile stalk and myonemes, the bell or the body can bend and move about or can swim in the surrounding water.

3.5.4 Nutrition

Vorticella is omnivorous having **holozoic** mode of nutrition. Food consists of small protozoans, bacteria and organic bits. As explained earlier, food granules collect in the cytopharynx due to the beatings of cilia. There, the food particles along with some water, form **food vacuoles**. These food vacuoles finally pinched off into the endoplasm. These food vacuoles circulate in the endoplasm in an irregular manner. During the circulation, the food is digested and absorbed into the surrounding endoplasm. The absorbed food material is partly synthesised into protoplasm. A part of it is converted into storage material, the **glycogen granules**.

To remove, throw or void the feces or unused food substances from the body is termed **egestion**.

The undigested food collects near the lower end of the gullet and pass through the **cytopyge** into the vestibule and finally is egested outside.

3.5.5 Respiration and excretion

No special organelles are present for these functions. Gaseous exchange and the removal of nitrogenous material take place through the general body surface.

3.5.6 Osmoregulation

The contractile vacuole performs the function of **osmoregulation**. Excess water from the cytoplasm gets accumulated into the contractile vacuole which discharges it into the vestibule by the reservoir. From the vestibule the water flows out with the undigested food. The contractile vacuole is a pulsating structure which contracts after every six seconds.

3.5.7 Reproduction

Reproduction takes place by three methods:

- 1) Asexually by longitudinal binary fission;
- 2) Sexually by conjugation, and
- 3) encystment.

1. Binary Fission

It is the common method of asexual reproduction by division of a cell into two equal parts. It occurs in a longitudinal fashion. During this process, the oral disc is withdrawn and the peristomial collar closes over the disc. The body becomes depressed, shorter, broader and transversely elongated. The macronucleus becomes short and straight and lies transversely in the middle. It then divides amitotically into two. The micronucleus also divides mitotically into two. The body now

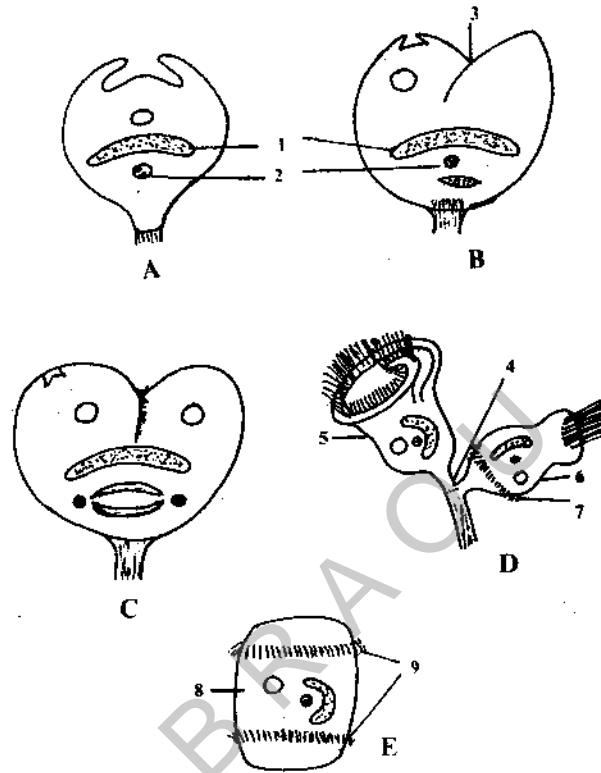

Fig. 3.6. Stages in longitudinal binary fission in *Vorticella*. 1. Meganucleus 2. Micronucleus 3. Longitudinal furrow 4. Unequal longitudinal divisions 5. Parent individual 6. Daughter individual 7. Aboral cilia Telotroch 8. Circlet of cilia.

starts dividing with a constriction formed in the centre of the anterior end. The constriction now deepens unequally dividing the peristome and the whole length of the body into 2 unequal parts. This results into a larger and a smaller daughter individual. The latter develops a circlet of aboral cilia, becomes cylindrical and gets detached from the larger individual and swims away. It is called a telotroch. It swims actively with the help of the newly developed posterior ring of cilia with its aboral end pointing forward. After sometimes the telotroch settles down by its aboral end with the help of an adhesive disc called scopula. In this attached stage, the young vorticella resembles a stalkless ciliate scyphidia; thus this stage is called scyphidia stage. The scopula secretes a stalk, a new disc is formed and the telotroch assumes an adult form. The complete process of longitudinal unequal binary fission takes place in about 20 to 30 minutes. (Fig. 3.6)

2. Conjugation

Conjugation (Fig. 3.7) is the sexual mode of reproduction. It takes place between two unequal individuals or conjugants. One is large and stalked - the macroconjugant and the other is small,

and free swimming - the **microconjugant**. It is also suggested that the macroconjugant can be considered as the inactive female conjugant or the **macrogamete**, and the microconjugant, as the active male conjugant or the **microgamete**.

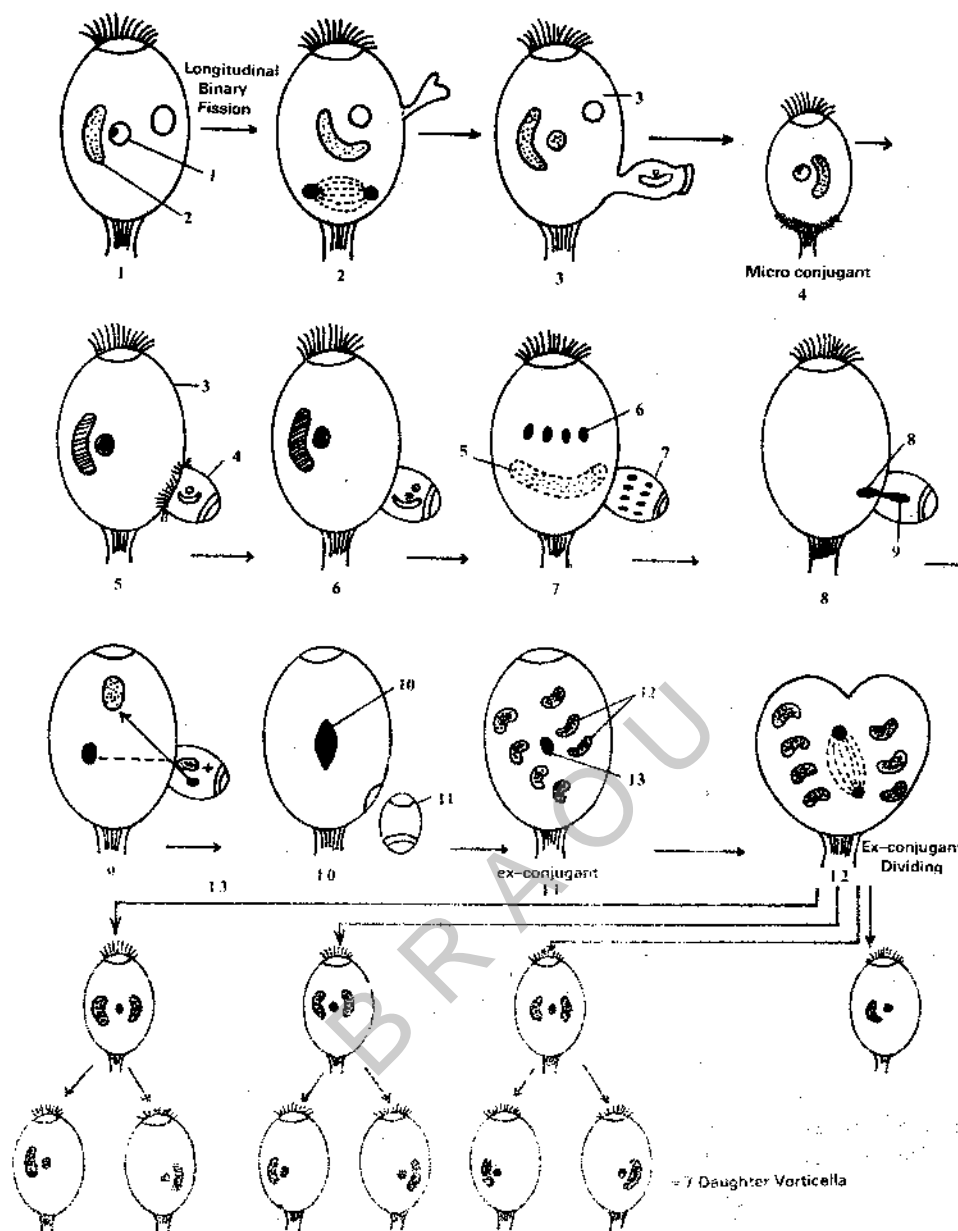

Fig. 3.7 Process of conjugation in *Vorticella*. Stages 1-4 shows the formation of sexual forms (Macroconjugant and microconjugant). Stages 5-14 shows the process of conjugation and formation of daughter individuals. 1. Micronucleus 2. Macronucleus 3. Macroconjugant 4. Microconjugant 5. Disintegrating macronucleus 6. Four micronuclei 7. Eight micronuclei 8. Female pronucleus 9. Male pronucleus 10. Synkaryon 11. Detaching microconjugant 12. Meganuclei 13. Micronuclei.

Formation of conjugants: The conjugants are formed by longitudinal binary fission which is much more unequal than the asexual binary fission. The macroconjugant possessing fixed stalk resembles an adult vorticella. The microconjugant develops a circlet of cilia at its posterior end, detaches from the parent body and swims away. It cannot develop into an adult. It resembles a telotroch, but is much smaller in size. It can survive for about 24 hours. During this period it should come in contact with a freshly formed macroconjugant which, however, also attracts it for a few hours only.

Union of conjugants: When a free swimming *microconjugant* comes in contact with a *macroconjugant*, it attaches by its aboral end to the lower part of the body of the macroconjugant near the stalk. It then loses its cilia and other organelles. The pellicle between the two conjugant disintegrates and their endoplasms become continuous.

Process of conjugation: Now the process of conjugation commences and is completed in 12 to 24 hours. The macronucleus in both the conjugants starts disintegrating and finally disappears. Thus, it does not play any vital role during conjugation. The micronucleus in each conjugant divides in a typical manner. In the microconjugant it divides three times, mitotically, resulting into 8 nuclei; whereas in the macroconjugant it divides only twice by the same nuclear division, forming 4 nuclei. Now 7 nuclei of the microconjugant and 3 nuclei of the macroconjugant degenerate and are absorbed in the endoplasm. Thus only one micronucleus remains in both the conjugants. It then divides mitotically into 3 pronuclei or gametic nuclei. One of them is called the **migratory pronucleus** or male pronucleus, the other is known as **stationary** or **female pronucleus**.

Nuclear Transfer: The migratory pronucleus of the microconjugant crosses over to the macroconjugant and fuses with its stationary pronucleus, forming a **synkaryon** or fusion nucleus or conjugation nucleus. But the migratory pronucleus of the macroconjugant and the stationary pronucleus of the microconjugant do not fuse and both degenerate. In this way there is only one side transfer or fusion of nuclei as the second fusion is abortive. The microconjugant with the synkaryon is termed as a **zygote**. The microconjugant, which is without any nuclear apparatus shrinks and drops off and its contents are absorbed in the **zygote**. With this the process of conjugation ends.

Development in the zygote or ex-conjugant changes: The zygote is now called the **ex-conjugant**. The synkaryon becomes elongated and divides 3 times mitotically into 8 daughter nuclei, of which seven enlarge to become macronuclei, while the (eighth) smaller nucleus remains as micronucleus. The micronucleus then divides into 2. The division of the ex-conjugant now takes place. First, it divides into 2 daughter individuals, one of them receiving one macronucleus and 4 macronuclei, whereas the other receives a micronucleus and the remaining 3 macronuclei. The two daughter cells and their micronuclei divide twice, whereas all the macronuclei are just distributed. The individual with 4 macronuclei results into four daughter cells, each with a micro and a macronucleus. On the other hand the individual with 3 macronuclei forms only three daughter cells, each possessing a micro and macronucleus. In all seven daughter individuals are produced. Each acquires a stalk, adheres to some substratum and becomes an adult. Thus, it has been observed that during conjugation it is the micronucleus which is active all the time. It divides and re-divides and gets distributed in the daughter individuals. The macronucleus is almost passive. It disintegrates and disappears in the conjugant and then in the exconjugants, it is simply distributed in the seven daughter individuals.

Formation of conjugants: The conjugants are formed by longitudinal binary fission which is much more unequal than the asexual binary fission. The macroconjugant possessing fixed stalk resembles an adult *Vorticella*. The microconjugant develops a cirlet of cilia at its posterior end, detaches from the parent body and swims away. It cannot develop into an adult. It resembles a telotroch, but is much smaller in size. It can survive for about 24 hours. During this period it should come in contact with a freshly formed macroconjugant which, however, also attracts it for a few hours only.

Union of conjugants: When a free swimming microconjugant comes in contact with a macroconjugant, it attaches by its aboral end to the lower part of the body of the macroconjugant near the stalk. It then loses its cilia and other organelles. The pellicle between the two conjugant disintegrates and their endoplasms become continuous.

Check your progress - 3

1. *Verticella* is commonly known as

3.6 SUMMARY

Elphidium or *Polystomella* is a shelled protozoan with many chambered body. Two distinct forms

appear. *Monocystis* is an endoparasite of earthworm. Physiology of both *Elphidium* and *Monocystis* is simple. The life cycles of both the types exhibit alternation of generations. *Vorticella* is a sessile ciliate. The body functions simple but an improvement upon the earlier two types. Reproduction both asexual and sexual. Sexual conjugation results seven daughter individuals.

3.7 CHECK YOUR PROGRESS — MODEL ANSWERS

Check your progress - 1

1. dimorphism

Check your progress - 2

1. earthworm, Seminal Vesicles

Check your progress - 3

1. bell animalcule

3.8 MODEL EXAMINATION QUESTION

I. Answer the following in about 30 lines.

1. Describe the process of reproduction in *Elphidium*.
2. Describe the life history of *Monocystis*.
3. Describe the structure of *Vorticella*.
4. Describe the process of conjugation in *Vorticella*.

II. Answer the following in about 10 lines.

1. Structure of *Elphidium*.
2. Structure of *Monocystis*.
3. Gametogony in *Monocystis*.
4. Nutrition in *Vorticella*.
5. Binary fission in *Vorticella*.
6. Transference of *Monocystis*.

UNIT - 4 PROTOZOAN DISEASES

Contents

- 4.1 Objectives
- 4.2 Introduction
- 4.3 *Leishmania donovani*
 - 4.3.1 Morphology
 - 4.3.2 Life cycle
- 4.4 *Entamoeba histolytica*
 - 4.4.1 Morphology
 - 4.4.2 Life cycle
 - 4.4.3 Pathogenecity
 - 4.4.4 Preventive measures or prophylaxis
- 4.5 Malarial Parasite (*Plasmodium*)
 - 4.5.1 History
 - 4.5.2 Life cycle of malarial parasite
 - 4.5.3 Control measures
 - 4.5.4 Treatment
- 4.6 Summary
- 4.7 Check Your Progress-Model Answers
- 4.8 Model Examination Questions
- 4.9 Glossary

4.1 OBJECTIVES

This unit is a brief introduction of protozoan parasites of human importance. At the end of this unit you will be able to explain the structure and life cycles along with pathogenecity and control measures of the causative agents of Kalaazar, Amoebiasis and malaria.

4.2 INTRODUCTION

Kalaazar is caused by *Leishmania donovani*. Kalaazar or Visceral Leishmaniasis an important and common disease in India, eastern Asia, parts of Africa and South America Kalaazar was a public health problem

Entamoeba histolytica is the best known human parasite, causing amoebic dysentery. It was first discovered by Losch in 1875. & *E. histolytica* is universal in distribution. It is found in tropical, subtropical, temperate and even in arctic and antarctic regions. It is prevalent in China, India, Mexico and parts of south America.

Plasmodium vivax is responsible for the well known disease malaria in tropical and temperate regions. It is almost cosmopolitan in distribution

4.3 LEISHMANIA DONOVANI

Phylum	Protozoa
Sub-Phylum	Plasmodroma
Class	Mastigophora
Sub-class	Zoomastigophora
Order	Protomonádiana
Genus	<i>Leishmania</i>
Species	<i>donovani</i>

Leishmania donovani is the Cause of Kalaazar or Visceral Leishmaniasis, an important and common disease in India, Eastern Asia, parts of Africa and south America. Kalaazar was a public health problem in the 1940's, being endemic in Assam, West Bengal, Bihar, Eastern districts of U.P. and Tripura. It was also prevalent in West Spain, Yugoslavia, Greece and Northern Italy. In the Middle East, it is endemic in Arabia and Iraq. The parasites which lie chiefly within endothelial cells are especially abundant in the spleen, liver, and bone marrow. They are also found within endothelial leucocytes in the peripheral blood, particularly late in the disease. It is also found in cats and dogs, which act as normal or reservoir hosts.

4.3.1 Morphology

The colourless microscopic parasite is round or oval in shape measuring about 2 to 4 microns in diameter. The body is rounded by a pellicle. Cytoplasm, which is not differentiated into ectoplasm and endoplasm, contains a spherical nucleus. A blepharoplast, a parabasal body and a rhizoplast are present but a flagellum is absent. (Fig. 4.1. A-C).

4.3.2 Life Cycle

The life cycle is completed within two hosts, a Primary host (man) and a secondary invertebrate host (blood sucking sand fly of the genus *Phlebotomus*).

In the fly

The sand fly serves as the intermediate host or the secondary host or the carrier. When the blood sucking fly takes a meal from the primary host, the parasites pass into the alimentary canal of the fly. Here the parasite becomes enlarged with a large nucleus and acquires a short free flagellum which arises from the blepharoplast, situated near the anterior end of the body. This parasitic form with a short free flagellum is known as the leptomonad. This infective stage is released into the human blood when the fly bites a man. In the primary host the leptomonad forms changes into the adult *Leishmania* stage. (Fig. 4.1).

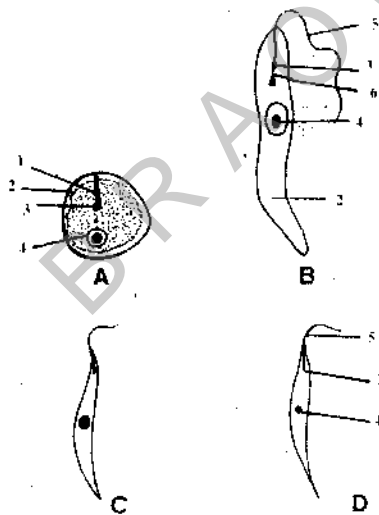

Fig. 4.1. *Leishmania*. A. Adult form. B. Young form. C. Leptomonad forms. 1. Rhizoplast 2. Cytoplasm 3. Blepharoplast 4. Nucleus 5. Flagellum 6. Kinetoplast.

In man

The parasite divides by binary fission repeatedly giving rise to a large number of parasites.

Pathogenicity

Kalaazar (Kala: black; azar: sickness) is a malaria like disease which causes irregular fever, enlargement of liver and spleen accompanied with anaemia. The skin colour turns black resulting into leukopaenia. If the disease is not properly treated it also may prove fatal.

Locomotory organelles, vacuoles, mouth gullet etc. are totally absent because of its parasitic mode of life.

3.4.2 Reproduction and life History

The life cycle (Fig. 3.4) of *Monocystis* is completed in a single host, i.e. it is monogenetic. There is no intermediate or secondary host.

Gametogony

It is the sexual reproductive phase. It occurs in the following stages:

a) Syzygy

The mature trophozoite, after feeding actively enters this phase. Now the oval shaped parasite is called a **gametocyte** or **gamont**. The gametocytes come together in pairs and meet by their sides. They assume spherical or rounded form. The gametocytes secrete them a common thin walled protective cyst called a **gametocyst**, or conjugation 'cyst'. The cyst is double layered; the outer thick hard layer is called **epicyst** or **ectocyst** and the inner thin soft layer is known as the **endocyst**. Inside the cyst the gametocytes just lie very close together but do not fuse. Such an association is called **syzygy**.

b) Gametogony

Within the cyst the gametocytes shrink, and exude some of their fluid, that fills the narrow space between them. It is followed by multiple fission or **gamogony** in which many small nucleated bodies are present. They are called the **gametes**. As the gametes produced by the gamonts are similar in shape and size, and even equal in number (usually 64), they are called **isogametes**. The

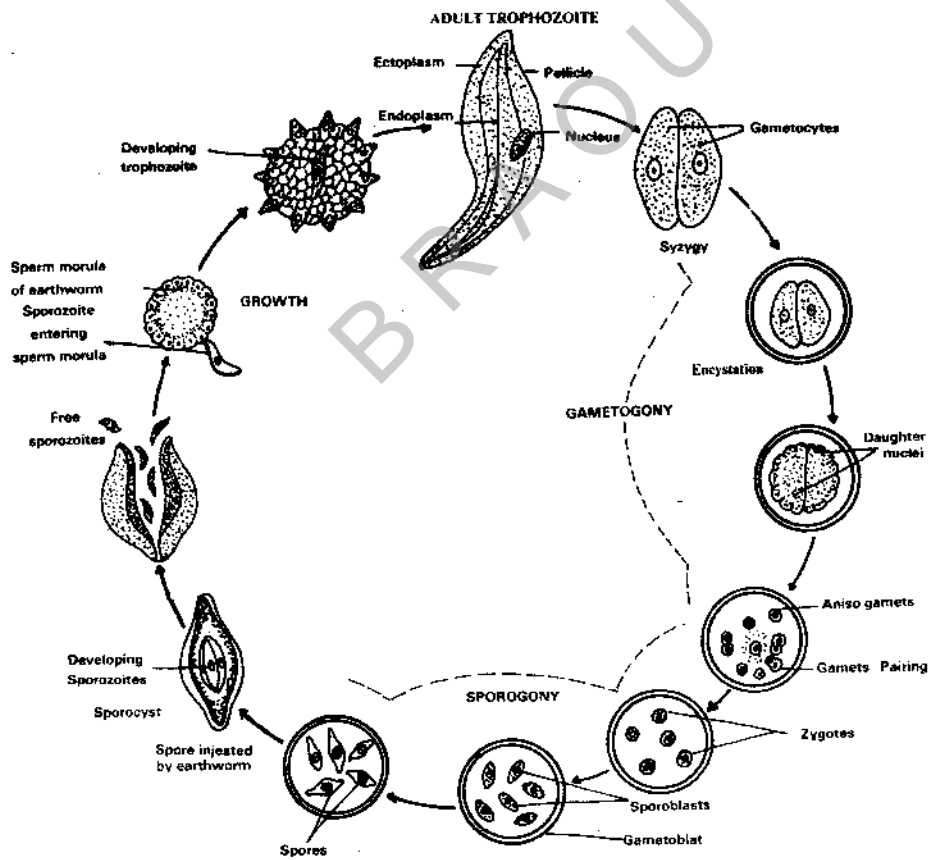

Fig. 3.4. Life Cycle of *Monocystis*.

Control Measures

The main control measure is to kill the sand flies. For this the following methods are adopted:

1. To spray insecticidal sprays, such as DDT, HCH and Dieldrin.
2. The sanitary conditions are to be improved by: (i) Eliminating the breeding places of sand flies, such as cracks and crevices in buildings. (ii) Removing shrubs and vegetation near human dwellings. (iii) Keeping the cattle sheds and poultry at a fair distance from dwelling.

Treatment

Leishmanian diseases are cured by following medical methods:

1. Intravenous injections of sodium antimony gluconate for 10-14 days.
2. Intravenous injections of Pentamidine isoethionate.

Doses of Tarter Emetic or Sodium antimony tartarate.

3. Two groups of antimony compounds are used as drugs; pentavalent compounds available in the market under the trade names of Neostiboran, Neostan, Solutibosan and Urea Stibanine are extensively used.

Check your progress - 1

1. The life cycle of Leishmania is completed in two hosts a primary host _____ and a secondary invertebrate host _____

4.4 ENTAMOEBIA HISTOLYTICA

Phylum	Protozoa
Sub-Phylum	Plasmodroma
Class	Sarcodina
Order	Amoebina or Lobosa
Genus	<i>Entamoeba</i>
Species	<i>histolytica</i>

It is the most pathogenic of the enteric amoebae, causing amoebic dysentery or intestinal amoebiasis, it is universally distributed and a varying percentage of various population groups in the temperate and tropical zones are infected with it. The parasite is mostly prevalent in Mexico, India, China and parts of South America where unhygienic sanitary conditions prevail.

Entamoeba histolytica was first discovered by Lambi in 1859 and its parasitic nature was described by a Russian zoologist, Losch in 1875.

The parasite inhabits the lower portion of the small intestine, mucus and sub-mucus layers of the entire large intestine (colon) of man. It also occurs in the appendix. In chronic cases it may enter the liver, lungs, brain and spleen, causing secondary manifestations.

4.4.1 Morphology

It measures about 10 to 50 microns in diameter. The cytoplasm is differentiated into outer clear ectoplasm and clear granular endoplasm. The nucleus is round, with a delicate ring of chromatin around the periphery. The nucleus has a small, delicate, centrally located karyosome. Many food vacuoles, ingested red blood cells and bacteria are found in the endoplasm. A clear, hyaline pseudopodium is given out, which renders unidirectional movement.

4.4.2 Life cycle

The parasite has four distinct phases: trophozoite, pre-cystic, cystic and metacystic stages. The trophozoite is the feeding and growing stage, the precystic and the cystic are the asexual reproductive stages, and the metacystic stage is the infective stage. (Fig. 4.3)

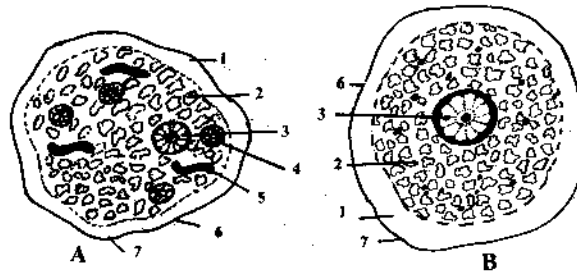

The 4.2. *Entamoeba histolytica*. A. Trophozoite form. B. Minuta form. 1. Ectoplasm 2. Endoplasm 3. Nucleus 4. Ingested R.B.C. 5. Ingested Bacteria 6. Plasma lemma 7. Pseudopodium.

The life history of *Entamoeba histolytica* is **monogenetic**, as it completes within a single host.

Encystment

The trophozoite after feeding, growing and multiplying by binary fission, come out from within the tissues into the lumen of the large intestine, where the process of encystment begins. The parasite becomes spherical and smaller and the food vacuoles disappears. These forms are called precyst or **minuta**. They secrete a thin resistant cell wall around them. There is one typical nucleus and a delicate non-granular cytoplasm. This initial encystment stage with a single nucleus is called a **uninucleate** cystic form. Soon the nucleus divides twice into four daughter nuclei. Now the cyst becomes **tetra-nucleate** or **quadri-nucleate**. It measures from 5 to 10 microns in diameter. In this stage characteristically, there appears rather large cigar shaped chromatid bodies. The complete process of encystment or encystation is over within a few hours.

The cysts are the infective forms of the parasite. They are highly resistant to desiccation, temperature and chemicals. The mature cysts pass out intermittently with the faeces of man.

Transmission

The cysts remain viable under favourable conditions for a long period outside the human intestine.

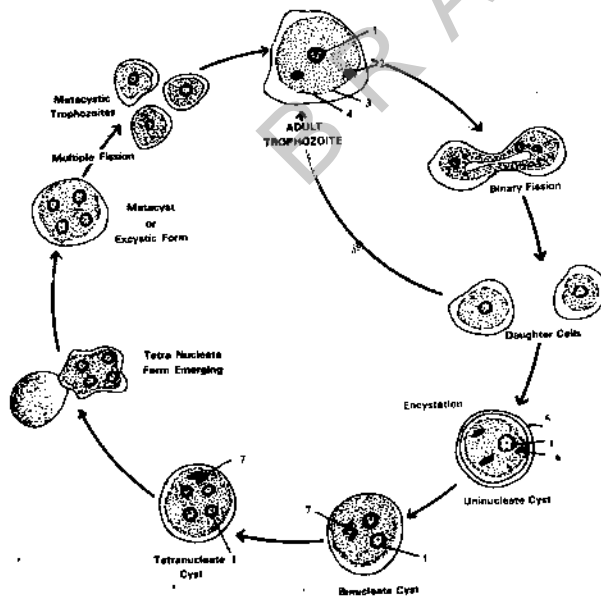

Fig. 4.3. Reproduction and Life cycle of *Entamoeba histolytica*. 1. Nucleus 2. Ingested R.B.C. 3. Ectoplasm 4. Endoplasm 5. Cyst Wall 6. Glycogen 7. Chromatid body.

Infection to new host is affected by the intake of contaminated food and drinks. Contamination occurs by houseflies, cockroaches and unhygienic persons handling the food. Such mode of infection is called contamination.

Encystment

On being swallowed along with contaminated food, the cysts reach the human intestine where the cyst wall gets dissolved by the digestive juices and the tetranucleate parasite emerges out. This process is called excystment or excystation and the parasitic stage is called excystic or metacystic stage.

Metacyst

A metacyst undergoes a series of nuclear and cytoplasmic divisions, forming 8 small uninucleate daughter amoebulae. They pass into the large intestine, invade the mucous lining and grow into mature trophozoites. The uninucleate metacystic forms may also remain inside the lumen of the colon and become the precystic or minuta forms.

The life-cycle of *Entamoeba* is marked only with asexual reproduction. There is no intermediate or secondary host. Housefly and cockroach act as the transmitters or carriers.

The variation in the size of the cysts and trophozoites of *E. histolytica*, has led to an arbitrary classification into two races. The large race comprises those with average cyst size of 10 microns and over, and the small race those with average cyst size under 10 microns. The former is associated with the most severe pathologic lesions, i.e. acute amoebiasis, dysentery, liver, lung and brain abscess, and cutaneous amoebiasis. While, the latter one tends to be found in persons with chronic gastrointestinal disease. They do not ingest red blood cells.

4.4.3 Pathogenecity

E. histolytica is the causative agent of the most common disease, the amoebic dysentery or amoebiasis from which about 60% human population suffers. It also causes liver, lung, and brain abscess.

The different diseases resulted by the presence of this parasite have been listed below:

1. Amoebic dysentery

The symptoms of this conditions are passing out of blood and mucous along with the stools.

2. Chronic intestinal Amoebiasis

Chronic amoebic dysentery turns into intestinal amoebiasis, in which a person suffers from short bouts of diarrhoea intermingled with periods of constipation. There may be selective dyspepsia to certain foods, such as milk and greasy foods, with considerable gas, flatulance, abdominal discomfort, nausea, nervousness, and general debility. Persons carrying the trophozoites for a long period lead almost normal life and serve as carrier of the disease.

3. Abscess

Sometimes the trophozoites may gain entrance into the circulatory system and thus develop secondary extra intestinal sites, such as liver, lungs, brain, and spleen etc.

4. Cutaneous Amoebiasis

Cutaneous amoebiasis occurs most frequently in the perianal region or on the buttocks.

4.4.4 Preventive measures or Prophylaxis

To control amoebiasis and its related manifestations various personal and community prophylactic measures should be adopted.

I. Personal preventive measures

The following personal hygienic habits should be inculcated:

1. Drinking boiled water and properly cleaned and washed vegetables and fruits, if possible sterilize them by keeping them immersed for a few seconds in hot water.
2. Maintaining cleanliness of the body. Washing hands with soap and water before taking meals, after using toilet and handling dirty articles.
3. Regularly cutting finger nails.
4. Avoiding contamination of food articles by protecting the eatables from flies, rats and cockroaches etc.
5. Adopting proper defecation habits by avoiding defaecation in open places, fields or streets.

Check Your progress

1. The life history of *Entamoeba histolytica* is as it completes with in a single host

4.5 MALARIAL PARASITE (*Plasmodium*)

Phylum	Protozoa
Sub-Phylum	Plasmodroma
Class	Sporozoa
Order	Haemosporida
Family	Plasmodidae
Genus	<i>Plasmodium</i>
Species	<i>vivax</i>

Malaria is perhaps the oldest known human disease. It was known to the Greeks who thought it was due to bad air of swamps and damps (L. mala: bad; aria; air). It is a common disease of the tropical and many temperate countries. It is still considered to be a very important disease in much of the world and is responsible directly or indirectly for much debilitation and death. It is caused by an intracellular, blood parasite called *Plasmodium*.

Four species of *Plasmodium*, are known, viz, *vivax*, *falciparum*, *malaria*, and *ovale*. *P. ovale* is encountered less frequently as it is found only in East and West Africa and the Phillipines. They cause different types of malaria as shown in the Table-I. Of all, the most severe is *P. falciparum*, as drug resistant strains of malaria of this species are confronting the clinicians.

4.5.1 History

As earlier mentioned in the introduction, malaria is known to the human beings from thousands of years. But major breakthroughs, discoveries and findings date as late as the 18th century. The important dates and years of significant work on the malarial parasite, its life cycle etc. are given below:

- 1827 **Macculloch** gave the name "Malaria".
- 1881 **Alphonse Laveran**, French Army Surgeon in Algeria-Discovered for the first time the *Plasmodium*.
- 1894 **Sir Patrick Manson**, a Scottish Doctor in Formosa (Taiwaan) — suggested the role of mosquitos in transmission of malaria.
- Aug. 29,
1896 **Sir Ronald Ross**, Indian Military Doctor, at Secunderabad Cantonment Hospital, discovered the carrier of *Plasmodium*, i.e. female *Anopheles* mosquito.
- 1898 **Grassi**, an Italian, and his collaborators worked out the complete sexual life cycle of the malarial parasite in the female *Anopheles* mosquito.
- 1948 **Col.Short & Graham**, British Protozoologists, discovered the pre-erythrocytic cycle in the human liver.

4.5.2 Life cycle of Malarial Parasite

The life cycle of the parasite, causing malaria is completed in two hosts; One primary host — man, and the other intermediate host or secondary host or the carrier — female *Anopheles* mosquito (Fig. 4.4)

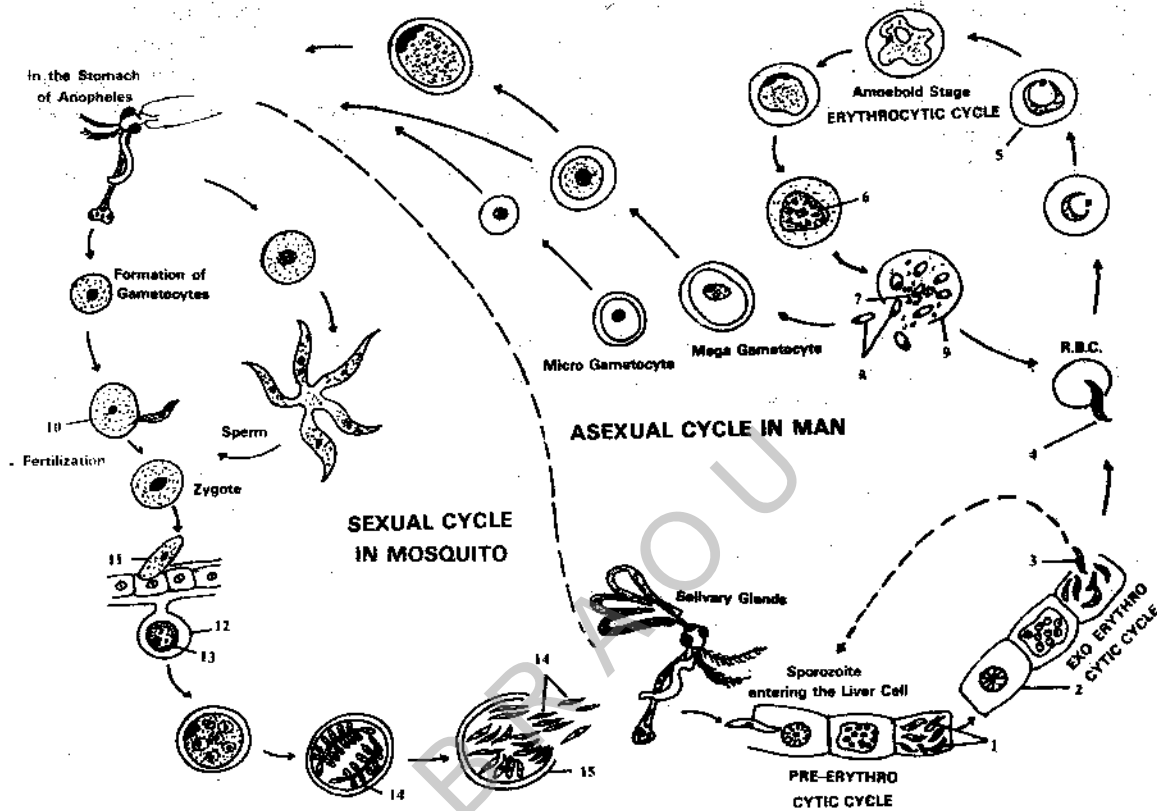

Fig. 4.4 Life cycle of *Plasmodium*. 1. Cryptomerzoites. 2. Liver cell. 3. Metacryptomerzoites. 4. Merozoite entering R.B.C. 5. Signet ring stage. 6. Multiple fission. 7. Haemozoin granules. 8. Merozoites 9. R.B.C. 10. Ookinete piercing the stomach wall. 12 Cyst. 13. Oocyst. 14. Sporozoites proceeding towards the salivary glands 15. Cyst wall rupturing.

Transmission of the parasite from man to man is through the bite of the mosquito, which is more or less life inoculation. Nevertheless, there are other means, such as congenital infection, use of contaminated needles by drug addicts, and particularly by blood transfusion.

The life cycle of the parasite in man is divided into three phases.

1. **Pre-erythrocytic schizogony:-** Soon after their entry into the human blood the parasites disappear from the peripheral circulation and attack the parenchymal cells of the liver. In the liver they feed and reproduce by asexual multiple fission. The effected liver cell ruptures and the parasites come out as **cryptomerzoites**.

The cycle lasts for 5-15 days.

2. **Exo-erythrocytic schizogony:-** This is the repetition of the previous cycle. The parasites are called meta crypto-merozoites. Some of these enter the red blood corpuscles and initiate the erythrocytic cycle, while a few attack fresh liver cells to re-start the cycle in liver.
3. **Erythrocytic cycle or schizogony:-** The *merozoites* from liver cells enter the R.B.C. and start feeding. They pass from *trophozoite* to *signet ring stage* and then to the *amoeboid stage*. They now divide by asexual multiple fission, and also produce the toxic haemozoin, causing malaria. The R.B.C. wall gets ruptured and the parasites come out along with haemozoin. This cycle is over in 48-72 hours, depending upon the *Plasmodium* species. After several asexual generations, the parasites are transformed into male and female gametocytes. Further cycle takes place in female *Anopheles* mosquito, as the gametocytes enter into the mosquito along with the blood sucked from an infected person.

Sexual cycle in mosquito:- In the stomach of the mosquito the male and the female gametocytes develop into gametes, sperms and ova. Fertilization takes place, and the zygote is formed which changes into a motile ookinete. Ookinete pierces the stomach wall, comes to lie on the outer side, gets encysted and divides by asexual process called sporogony. Many sickle-shaped sporozoites are produced which come out after the rupture of the oocyst. They proceed from the haemocoel to the salivary glands. The sporozoite is the infective stage of the life cycle of Plasmodium. They are retained in the salivary glands until the next blood meal, at which time they enter the new human host.

The sexual cycle in mosquito is completed in 2-4 weeks (Fig. 4.6)

Incubation period

The period from the first entry of the parasite into the blood through the mosquito bite, to the appearance of malarial symptoms, is known as the incubation period. It varies with different species. However it ranges from 8-40 days.

TABLE - 1.

Name of the Species	Disease	Liver	Cycle Blood	Incubation period
1. <i>P. Vivax</i>	Benign tertian Vivax malaria	8 days	48 hours	10-17 days
2. <i>P. falciparum</i>	Malignant tertian falciparum malaria, sub-tertian malaria.	5 days	48 hours	8-12 days
3. <i>P. malariae</i>	Quarten malaria	14-15	72 hours	21-40 days
4. <i>P. ovale</i>	Ovale malaria	9 days	48 hours	10-17 days

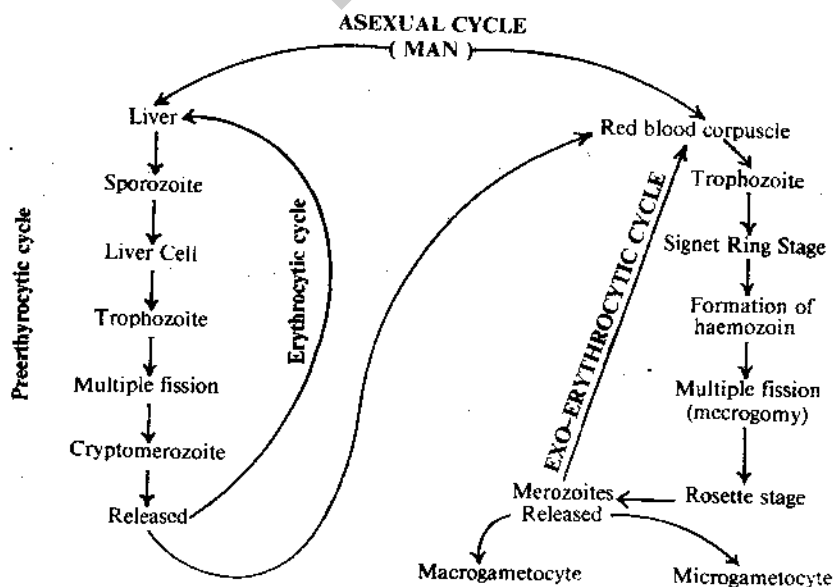

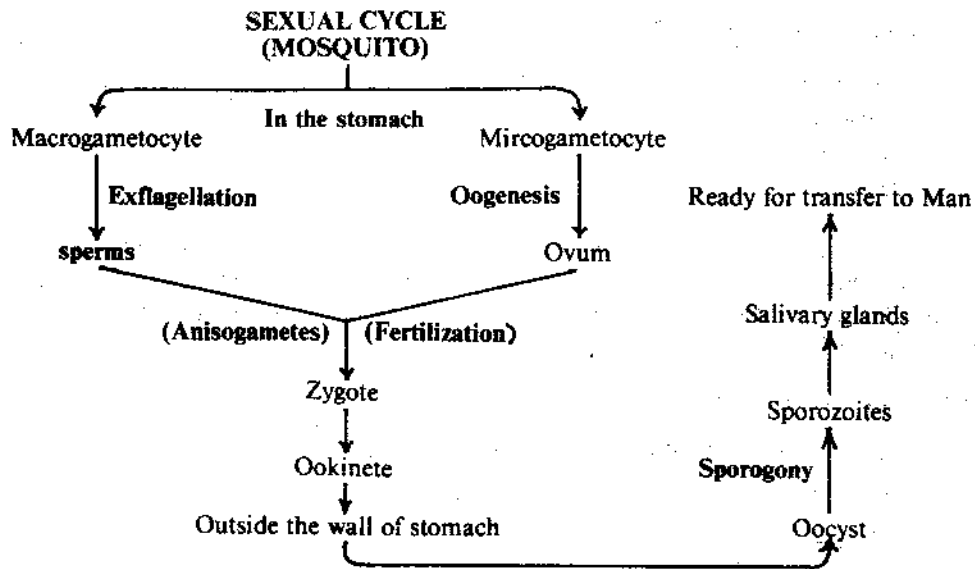

Pathogenicity

Plasmodium causes different types of malarial fever as already shown in Table-1. The symptoms of malaria are being discussed here.

The Malarial Symptoms

A day or two before the malarial fever the following symptoms are shown by the patient.

- i) Exhaustion and frequent yawning.
- ii) Nausea, headache and muscular pain.
- iii) Constipation.

A typical attack of malaria has three stages; cold, hot and sweating.

4.5.3 Control measures

To control malaria several measures are to be adopted. First and foremost is the elimination of the carrier i.e. mosquitoes, next is to maintain substantial hygienic and sanitary conditions. These measures fall into the following categories.

1. Mosquito control measures

1. Anti-larval measures

Peri-domestic measures, control of breeding points. The larvae or the future mosquito should be destroyed to inhibit a new generation of the transmitters. The different methods to ward off the mosquito to larvae are:

- A. Environmental control
- B. Chemical Control
- C. Biological Control

Under environmental control breeding of mosquitoes are eliminated. It is known as 'source reduction'. In chemical control the larvae and other stages are killed by spraying petroleum, kerosine oil or crude oil on water surfaces. Sprays or DDT, DDD, BHC, also poison the waters containing larvae. The biological control is ensured by introducing certain fishes like minnows, trouts, guppies and gambusia which eat away the larvae. Some aquatic insectivorous plants like Bladderwort are also the natural enemies of larvae. In Vector Control Research Centre, at Pondichery, a new species of waterbug has been discovered which feeds on mosquito eggs and larvae.

2. Anti Adult Measures

1. Residual Sprays
2. Space sprays
3. Fumigation
4. Genetic control

To get rid of adult mosquitoes, sprays of DDT, gammexene, pyrethum, malathion chlordane etc. are very effective. Fumigation of naphtha products like cresol, taracaruphor etc. and that of garlic is useful. Genetic methods i.e. crossing Hamburg male mosquito with the Paris female mosquito has been suggested. The eggs thus produced do not hatch.

Protection against mosquito bites

As far as possible we should protect ourselves from the mosquito bite. For this, mosquito nets, screening and mosquito repellants should be used.

4.5.4 Treatment

If all the preventive measures fail and a person gets infected by a malarial parasite, prophylactic drugs are to be immediately used. Quinine preparations, under several names like Resochin, Camoquin, Cholorquin, Lariago, etc. by mouth or by injection are extensively in vogue. At the onset of the attack, a brisk, purge, followed by hot drinks is given. Aspirin or analgesics are given at the commencement of the hot stage. The bowels must be kept open by using light diet. If chronic malaria where anaemia sets in, iron tonics are administered.

Check your progress - 3

1. The life cycle of the parasite in man is divided into three phases and

4.6 SUMMARY

Kalaazar, a tropical disease, is caused by *Leishmania donovani*. It is an endoparasite of man. Sand fly is the carrier of the parasite. Life cycle is completed in man and the fly. Kalaazar causes malaria like disease. Sand flies should be avoided and proper medical treatment is to be taken. *Entamoeba histolytica*, the intestinal endoparasite, causes Amoebiasis in man, cockroach and through contaminated food. Amoebiasis results in amoebic dysentery, diarrhoea, ulcers of liver and other manifestations. Personal and community hygienic measures are to be adopted and suitable medicines should be administered. Malaria is the oldest known disease. It is caused by four species of the genus plasmodium. Female Anopheles mosquito is the carrier. Asexual cycle is found in the liver and R.B.C. of man, and the sexual cycle in the stomach of mosquito. Malaria is accompanied with shivering, higher fever, and sweating. It also results in anaemia. Both the larvae and adult mosquitoes should be destroyed. There are several other protective measures. Quinine preparations are most suitable.

4.7 CHECK YOUR PROGRESS — MODEL ANSWERS

- I. Check your progress - 1
man, sand fly (Tsetse fly)
- II. Check your progress - 2
monogenetic
- III. Check your progress - 3
Pre-erythrocytic Schizogony,
Exo-erythrocytic schizogony and
Erythrocytic schizogony

4.8 MODEL EXAMINATION QUESTIONS

I. Answer the following in about 30 lines

1. Explain the life cycle of *Entamoeba histolytica*, and describe the pathogenecity.
2. How amoebiasis is caused? What are its symptoms and control measures?
3. Describe briefly the life cycle of *Plasmodium*.
4. Describe the life cycle of *Plasmodium* in man.
5. Explain the sexual cycle of malarial parasite.
6. Write an essay on malaria highlighting its symptoms, control measures and treatment.

II. Answer the following in about 10 lines.

1. Write a note on Kalaazar.
2. Write down the cycle of *plasmodium* in the liver.
3. Structure of *Entamoeba histolytica*
4. Erythrocytic cycle of *Plasmodium*.
5. *Anti malaria* schemes.

4.9 GLOSSORY

Aboral	: The side of an animal away from the mouth (L. ab: from; oris: month).
Abscess	: Local inflammation, (Swelling, redness) of body tissues with deep form caused by bacteria which destroy the cells in the centre of the area and leave a cavity filled with pus.
Acellular	: Animals with a simple functional cell.
Alkaloid	: An organic substance of complex composition present in plants generally used for medicinal purposes.
Alternation of generations	: A succession of two generations of which one is asexual and the other sexual.
Anaemia	: Deficiency of red blood corpuscles of their haemoglobin, often causing paleness.
Analgesic	: Drug which kills or subsides pains.
Animalcule	: Microscopic animal.
Antibiotics	: Chemical substance developed as metabolic products by many microorganisms such as fungi, bacteria etc. which are used against infections by parasites.
Appendix	: An outgrowth from the large intestine of man.
Bilateral	: (L. bis: twice; latus: side) Having two sides.
Binary fission	: Asexual method of reproduction by division of a cell into two equal parts.
Bone marrow	: A yellow tissue in the central cavities of the larger bones; in adult mammalia it is the source of origin of red blood cells and certain types of white blood cells.
Blepharoplast	: A small structure of unknown function near the base of a flagellum, in certain protozoa. Also known as parabasal body.
Blood transfusion	: To pass blood under medical attention from one person to another in case of emergency.
Brackish	: Slightly salty.
Budding	: A method of asexual reproduction in many simple animals.
Calcareous	: (L. Calcartus: limy) Made up of calcium.
Chromatin bodies	: The protoplasmic substance in the nucleus of cells.
Cilia	: (L. Cilium: eyelid) Extremely fine filaments that move rythmically and cause locomotion.
Cocoon	: A protective covering for eggs in earthworms, and for pupa of an insect.

Cold blooded	: Those animals whose body temperature varies with the environment, such as, fish, amphibia and reptiles.
Colonial	: Group of organisms living together.
Conjugation	: A form of sexual reproduction (L. conjugare: to join together).
Constipation	: Condition of bowels in which defaecation is irregular and difficult.
Contamination	: Infection or pollution.
Copulation	: (L. Copula: bond) Sexual union of male and female.
Crustacean	: A large varied group of arthropods, mostly aquatic, such as shrimps, prawns and crabs.
Cutaneous	: Pertaining to the skin.
Cyclosis	: (GK Kyklosis: whirling around) Circulatory movement of protoplasmic structures within a cell, as in the case of the food vacuoles in
Paramecium	
Debility	: A lack or loss of strength. It may due to lack of muscle tone, malnutrition, disease or other causes.
Defaecation	: (L. defaecation: voiding of excrement). Evacuation of the bowels or faeces.
Desiccation	: Process of exhausting of all moisture.
Delirium	: A temporary condition resulting from injury or disease of the brain or acute illness, when the poison of the infection is carried to the brain. In this condition a patient shouts or fails to recognize surrounding persons.
Diarrhoea	: Excessive looseness of bowels.
Diatom	: Unicellular algae.
Diffusion	: Spreading or scattering of liquids or gases from one medium to the other.
Dimorphism	: Existing in two distinct forms.
Diploid	: (GK. Diploos: double) Having full number of Chromosomes.
Endoparasitic	: A parasite living inside the host.
Endothelial	: (GK. Endon: within; thele: nipple) Pertaining to endothelium. The simple squamous epithelium lining the heart, blood vessels and lymph vessels.
Enteric	: (GK. enteron: gut) Pertaining to alimentary canal.
Excrement	: Waste matter discharged from the body, especially faeces.
Fistula	: (L. Fistula: pipe) A fistula is an abnormal tube like passage permitting the flow of fluids and gases.
Flagellum	: A thread like outgrowth from a cell, larger than cilia, to propel a small organism or attract particles to it.
Flatulence	: An abnormal accumulation of gas (flatus) in the stomach or intestine.
Gamet	: A male or female reproductive cell.
Gametocyte	: The mother cell of a gamete.
Habit	: The bodily constitution.
Habitat	: The locality or external environment in which a plant or animal lives.
Haemocoel	: A large blood filled cavity surrounding most of the organs as in arthropods, molluscs etc.
Haemoglobin	: The red respiratory iron pigment of blood of vertebrates.
Haploid	: Having half the full number of chromosomes in a cell.
Holophytic	: Obtaining the food in a manner of plant.
Holozoic	: (GK. Holos: whole; zoon: animal) Obtaining the whole of its food in an animal like manner.
Ingest	: (L. ingestus: taken in) To convey food material into the alimentary canal or food cavity.
Karyosome	: An aggregation of chromatin in a resting nucleus.
Intracellular	: Within the cell.
Leptomonad	: A stage in the development of the parasitic flagellate Leishmania. It is named after the genus Leptomonas which it resembles.

Lesion	: Damage, injury, especially sickly change in functioning or texture of organ etc.
Leucocyte	: A colourless white blood cell. They are made in the bone marrow, the lymph system and the reticuloendothelial system.
Leucopenia	: A decrease in the number of leucocytes below normal limits.
Lumen	: (E. Lumer: light) The cavity of a tubular part of an organ.
Micron	: Measure of length one thousandth of a centimeter (One Millionth of a meter).
Mitosis	: Indirect cell division. The normal process of cell division.
Mixotrophic	: Mixed feeding i.e. both like an animal and a plant.
Monogenetic	: Parasites whose life cycle is completed in a single host.
Mucous layer	: Epithelium which secretes mucus, such as the alimentary canal.
Mucus	: A slimy solution of a mucin or other viscous substance secreted by a mucous gland or mucous membrane.
Multiple fission	: A type of asexual reproduction in protozoa.
Myonemes	: Contractile fibrils in the ectoplasm of many Protozoa.
Nausea	: The sensation of vomiting.
Necrosis	: The condition when tissues or entire organs deteriorate and die.
Nutrition	: The taking in, breaking down, absorption and assimilation of food.
Omnivorous	: Feeding on both animal and vegetable food.
Organelle	: Parts of a cell having a definite structure and function e.g. cilia, flagella etc.
Osmoregulation	: A mechanism for keeping the water content of an organism constant and counteracting the tendency for water to pass in or out by osmosis.
Perihaemal Tissues	: Glandular masses and secretory tissues, such as the liver, kidney and pancreas with a spongy appearance.
Paraglycogen	: Glycogen like bodies.
Pathogene	: A microorganism which is capable of producing a disease.
Pathogenicity	: Symptoms of a disease.
Pellicle	: A hard protective outer layer or protoplasm surrounding certain protozoa.
Perianal	: Around anus.
Peripheral	: External boundary or surface.
Plasmalemma	: The boundary layer or protoplasm of a cell or of a simple organism such as Amoeba.
Pollution	: Accumulation of materials where they are not wanted.
Primary host	: The host in which a parasite spends most of its adult life.
Prophylaxis	: Preventive measures against disease.
Proteolytic enzyme	: An enzyme which breaks down proteins.
Pseudopodium	: (GK. Psuedes: false; pous: foot; eidors: form) Retractable and mobile elongation or protoplasm of varied and changing shape. Organelle of locomotion in a group of Protozoa.
Rhizoplast	: Protoplasmic thread connecting the basal granule of a flagellum with the nucleus or with the parabasal body in certain protozoa.
Saprophytic or Saprozoic	: Living on decomposing organic matter.
Schizogony	: Asexual reproduction in protozoa by multiple fission into schizozoites.
Secondary host	: The host in which a parasite lives for a short time (usually in its larval stage) before being transferred to spend most of its life in the primary or definitive host.
Scroza	: Delicate membrane of connective tissue lining the body cavities and reflected over many of the viscera including the alimentary canal.
Sessile	: Without a foot stock; attached by a broad base.
Siliceous	: Made up of silica.
Solitary	: Living along without companions, single, separate.
Sperm morula	: A spherical mass of cells from which spermatozoid develop and subsequently break away e.g. in the earthworm.

- Sub-mucous layer** : (L. Sub: under; mucous: mucous) The layer of fibrous, connective tissue that attaches mucous membrane to the adjacent parts.
- Syngamy** : Sexual union of male and female gametes.
- Temperate** : A zone between either tropic and the corresponding polar circle.
- Tropical** : A very hot zone.
- Vesicular nucleus** : The type of nucleus which consists of a nuclear membrane filled without the usual fine network of chromatin. There may be a coarse meshwork and sometimes a karyosome or central mass.
- Wriggling movements** : Twist or turn body about with short wriggling movement.

BRAOU

UNIT - 5 PORIFERA - GENERAL CHARACTERS AND CLASSIFICATION, STUDY OF SYCON AS A TYPE

Content

- 5.1 Objectives
- 5.2 Introduction
- 5.3 General Characters
- 5.4 Classification
 - 5.4.1 Calcarea
 - 5.4.2 Hexactinellida
 - 5.4.3 Desmospongia
- 5.5 Sycon
 - 5.5.1 Morphology
 - 5.5.2 Histology
- 5.6 Skeleton
- 5.7 Canal System
- 5.8 Reproduction
 - 5.8.1 Asexual reproduction
 - 5.8.2 Sexual reproduction
- 5.9 Development
- 5.10 Summary
- 5.11 Check Your Progress — Model Answers
- 5.12 Model Examination Questions
- 5.13 Recommended Books
- 5.14 Glossary

5.1 OBJECTIVES

The unit deals with the general characters and classes of phylum Porifera. The unit also depicts the study of sycon as the representative type of the phylum, its external and internal structure, various types of cells, skeleton, canal system and physiology.

After going through the description you will be in a position to explain that the poriferans are placed in multicellular animals with tissue level organisation without a mouth, digestive cavity or organs, depending on a unique water canal system.

5.2 INTRODUCTION

Phylum Porifera comprises sponges, which are multicellular animals of most primitive characters. Except a single family of fresh water all sponges are exclusively marine, found adhered to submerged substratum.

Sycon is a calcareous sponge with an internal skeleton composed of calcium carbonate spicules. It is typical example exhibiting salient features of the phylum.

5.3 GENERAL CHARACTERS

Phylum Porifera (L. Porus: pore: ferra: to bear) marks the beginning of multicellular animals. The group constitutes plant-like animals, incapable of movements. Their body organisation is higher than Protozoa but when compared to other Metazoa, they are simplest and the lowest. The group

'sponges' was separated from Protozoa by Haeckel in 1869. They do not possess well defined tissues and organs. Porifera includes about 5000 described species. The vase-shaped, cylindrical body consists of an extensive system of pores, canals and a number of wandering amoebocytes.

They have the following characteristics:

1. They are all aquatic, mostly found in sea water, where they are found attached to some substratum.
2. Body shape variable, vase-like, cylindrical, globular or irregularly branched without symmetry.
3. Colour variable - brown, grey, yellow, red, orange, violet, pink, black or white.
4. Solitary or colonial.
5. Multicellular, diploblastic. Outer dermal layer and inner flagellated layer, consisting of characteristic choanocytes. A gelatinous mesogloea or mesenchyma lies between the two. It is embedded with numerous free amoeboid cells of different types.
5. Body with many pores, canals or chambers, through which the water current flows:
7. Numerous small openings known as ostia are found laterally, whereas a large osculum is present distally. These two are communicated by a set of canals.
8. The central large cavity is called the spongocoel or paragastric cavity.
9. Skeleton is made up of spicules of calcium or silica and fibres of spongin.
10. No organs of locomotion, completely sessile.
11. No mouth and alimentary canal: nutrition is Holozoic and digestion is intracellular.
12. Organs of respiration and excretion lacking. Both the processes are carried out by diffusion.
13. Nervous system absent. Response to stimuli poor.
14. Reproduction both asexual and sexual. Former by regeneration, budding and special cell masses called gemmules. Latter by eggs and sperms. The free swimming larva is found in the life cycle.
15. They are not attacked or devoured by other animals. Their anterior cavities serve as temporary shelters for crustaceans, worms, and molluscs etc.
16. Sponges are of great economic importance. The skeleton of the sponge is in human use since the ancient greek days for washing and mopping. A few sponges are used for decoration and as articles of gift.

5.4 CLASSIFICATION

Phylum Porifera comprises three classes, which are:

1. Calcarea
2. Hexactinellida
3. Demospongia.

5.4.1 Class 1: Calcarea

- i. Marine sponge, inhabiting shallow waters.
- ii. Skeleton made up of calcareous spicules.
- iii. They measure 15 cms. in height with dull brown colour.
- iv. Body radially symmetrical, vase-shaped.
- v. Body surface bristly due to projecting spicules.
- vi. Choanocytes are comparatively larger.
- vii. Canal system of different types.
- viii. Asexual reproduction by budding.
- ix. A free swimming larval stage in the life cycle.
- x. The group consists of economically important sponges - the bag sponges. e.g. *Sycon*, *Grantia*, *Leucosolenia* (Figs. 5.1.A-C).

5.4.2 Class 2: Hexactinellida

- i. Found in deep sea, at depths of 300 feet to three miles.
- ii. Commonly known as glass sponge, as the skeleton is made up of hexactinal siliceous spicules found either separate or united in networks.
- iii. Body height 10-30 cms to 3 feet, with light colour.

- iv. Radially symmetrical body, cylindrical, vase or funnel shaped.
- v. Body wall lacks epidermal cells and mesenchymal matrix. The latter is made up of a network of strands formed by the union of branching pseudopodia of the amoebocytes.
- vi. The dermal layer is thin, the middle layer is thick and the gastral one is thin with irregular openings into the spongocoel.
- vii. The choanocytes are small and lack contractile power.
- viii. The canal system is simple.
- ix. Budding is the mode of asexual reproduction
- x. Larva is called *stereogastrula*
- xi. Class Hexactinellida comprises a few economically important sponges like *Euplectella* and *Hyalonema*. Dried Skeleton of *Euplectella* is a costly marriage gift in Japan *Hyalonema* is beautiful decorative sponge.
e.g. *Hyalonema*, *Euplectella*, *Pheronema* (Fig. 5.1. D-F).

5.4.3 Class 3: Demospongia

- i. The Demospongia are mostly numerous than other sponges, with a wide distribution.
- ii. The body is highly organised among all the sponges.
- iii. Mostly marine, but a few are found in fresh water.
- iv. Body shape and colour variable.
- v. Skeleton, when present, is of silicious spicules and spongin fibres.
- vi. Mesogloea abundantly contains contractile fibre cells, the *fibrocytes*, which possess a high contractile power.
- vii. Canal system is complicated.
- viii. Choanocytes are small.
- ix. Asexual reproduction by internal buds called *gemmules*.
- x. Larva is *stereogastrula*.
e.g., *Spongilla*, *Cliona*, *Chalina* (Figs. 5.1. G-I).

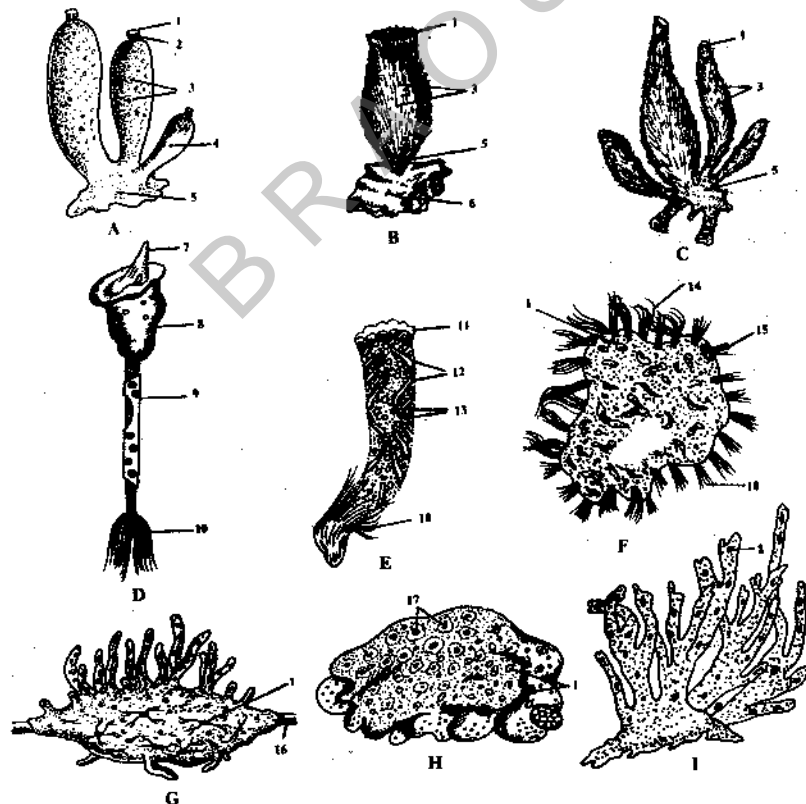

Fig. 5.1 Representatives of Porifera. A. *Sycon*. B. *Grantia*. C. *Leucosolenia*. D. *Hyalonema*. E. *Euplectella*. F. *Pheronema*. G. *Spongilla*. H. *Cliona*. I. *Chalina*. 1. Osculum 2. Oscular fringe 3. Ostia 4. Cylinder 5. Base 6. Substratum 7. Gastral cone 8. Body 9. Symbiotic polyps 10. Root spicules 11. Oscular sieve plate 12. Ledges 13. Parietal gaps 14. Marginal postals 15. Pleural postals 16. Stock 17. Cups of Coral.

5.5 SYCON

Phylum	Porifera
Class	Calcarea
Order	Heterocoela
Family	Sycettidae
Genus	<i>Sycon</i> (Scypha)

Habitat *Sycon* is a marine sponge found in the seas of many parts of the world, especially of Europe. It is solitary found attached to the surface of a rock and other solid substrata submerged in sea water.

5.5.1 Morphology

Sycon is a calcareous sponge, the skeleton of which is made up of spicules of calcium carbonate. The body consists of vase-shaped which are grey or light brown in colour. It measures 20-25 mm. in height and 5-6 diameter. The body is radially symmetrical.

Each vertical tube of *Sycon* (Fig. 5.2) has a large opening at its free distal end known as Osculum or the excurrent pore or exhalent pore. It is surrounded by large rod-like monaxon calcareous



Fig. 5.2. *Sycon* 1. Oscula 2. Branching cylinders of the sponge body 3. Ostia 4. Base.

spicules. On the body surface innumerable polygonal elevations are demarcated by linear depressions which run parallel to the sides of the polygons. In these depressions numerous minute pores are found. These are called the ostia or the incurrent pores, or the inhelent pores. During life in sea, water constantly enters the interior of the sponge through these pores and exit through osculum. Each vertical tube has a hollow interior known as the spongocoel, paragastric cavity, paragastror or the gastral cavity.

5.5.2 Histology

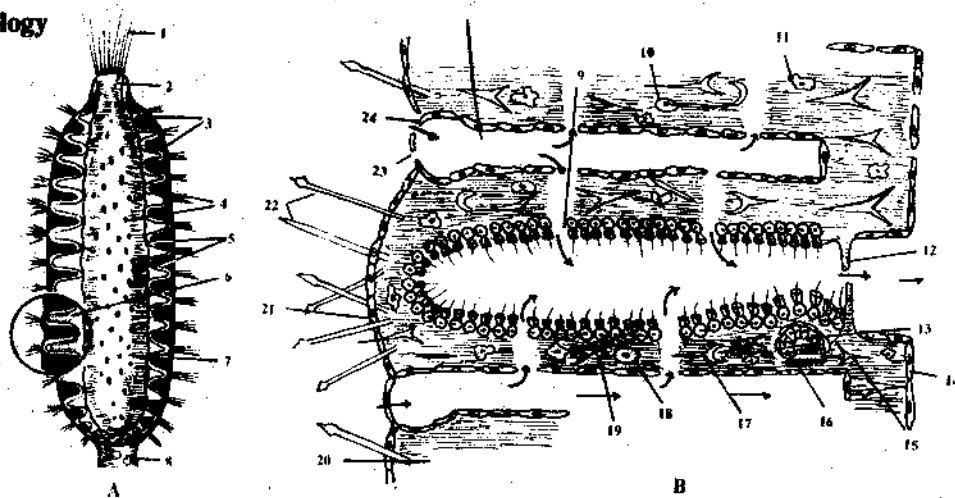

Fig. 5.3. *Sycon* A.L.S. of *Sycon* B. A part of verticle section showing histology and canal system (arrows indicating the path of water current). 1. Oscular fringe 2. Osculum 3. Gastric ostia 4. Dermal ostia 5. Incurrent canals 6. Flagellated chamber 7. Spongocoel 8. Stalk 9. Propyle 10. Scleroblast 11. Amoebocyte 12. Apopyle 13. Embryo 14. Gastral

The body wall comprising an outer layer called epidermis or demal layer, and an inner layer known as gastral layer. The space between these two layers is filled with a thin gelatinous matrix which contains several types of amoeboid cells. (Fig. 5.3 A & B)

The body wall is traversed by certain canals through which the water current, entering through the ostia, passes and finally reaches the large central paragastric cavity. Two main types of canals are present viz. the incurrent canals and the radial canals.

Epidermis or Dermal Layer: It is the outer layer covering the entire outer surface of the sponge. It is made up of flattened cells called Pinacocytes. It is large, flat and polygonal. A nucleus is found at the centre. Pinacocytes are contractile, and they serve to reduce the surface area of the sponge by withdrawal of their margins into the central bulge. They resemble the epithelial cells of higher animals.

Gastral layer: The inner layer is called the gastral layer. It lines the gastral cavity and the radial canals. It consists of two kinds of cells; flat epithelial cells which are almost like the pinacocytes of the epidermis, and the collar cells or choanocytes or flagellated cells.

Choanocyte: It resembles a choano flagellate Protozoa. It is oval or rounded with a nucleus and a few vacuoles. On the apical side a collar-like transparent protoplasmic outgrowth is present. The long whip like flagellum arises from the centrobalepharoplast, situated at the base of the collar



Fig. 5.4 Choanocyte of *Sycon*. 1. Flagellum 2. Process fused into collar 3. Collar 4. Centrobalepharoplast 5. Rhizoplast 6. Parabasal body 7. Nucleus 8. Cell membrane 9. Cytoplasm.

within the cell. A parabasal body lies just above the nucleus. It is connected with centrobalepharoplast by a thread like rhizoplast. The beating of flagella keep the current of water flowing in the sponge. (Fig. 5.4)

Mesenchyme: It is the space between epidermis and gastral layer. It is also called the mesogloea or the skeletogenous layer, for it contains the supporting skeletal elements called the spicules. Its gelatinous matrix has the following kinds of free wandering amoeboid cells.

- i. **Collencytes or Connective tissue cells:** They are small connective tissues cells with radiating processes or pseudopodia. They are star or stellate shaped. (Fig. 5.5)

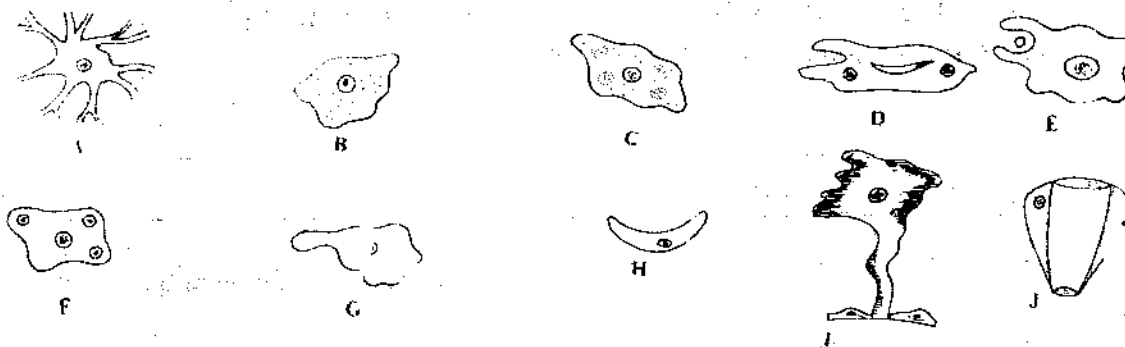

Fig. 5.5. Common types of cells found in the mesogloea in sponges. A. Collencyte B. Chromocyte C. Thesocyte D. Scleroblast E. Phagocyte F. Trophocyte G. Archaeocyte H. Myocyte I. Gland cell J. Porocyte.

- ii. **Chromocytes or Pigment cells:** They have lobose pseudopodia and possess pigment granules. They impart colour to the sponge.
- iii. **Thesocytes or Storage cells:** These are amoebocytes with lobose pseudopodia. They contain plenty of reserve food granules.
- iv. **Scleroblasts or Spicule producing cells:** These are the spicule producing cells which form the skeleton. The cells which secrete the calcareous spicules, as in *Sycon* are termed Calcoblasts.
- v. **Phagocytes:** As the name indicates these are the food collecting or capturing cells. They possess pseudopodia which are commissioned to engulf food, excreta, and damaged tissues.
- vi. **Trophocytes or Nourishing cells:** These are the transporting cells, transferring loaded digested food from one place to another.
- vii. **Archaeocytes:** These are the gamete producing cells or the sex cells. They possess blunt pseudopodia, large nucleus, and a granular cytoplasm. They also play a key role in the process of regeneration.
- viii. **Lophocytes:** They possess a tuft of fibrills at one or both ends. They are of uncertain function.
- ix. **Monocytes:** They are found around the osculum, ostia and apopyles-pores connecting canals. They are elongated contractile cells resembling the muscle cells of vertebrates. They regulate the opening and closure of osculum.
- x. **Gland cells:** They secrete mucus and are mostly found at the base. They hold in, adhesion of the sponge to any substratum.
- xi. **Desmocytes:** They lie at the basement of the canals. They are long and slender.

5.6 SKELETON

The skeleton of sponges is made up of various types of spicules which maintain the shape of sponge body and lend sufficient rigidity. It is also responsible to keep the sponge erect with sufficient flexibility.

In *Sycon* the spicules are made up of calcium carbonate and hence calcareous. They are secreted by special mesenchymal amoeboid cells, scleroblasts. The spicules are of four types.

- i. **Monaxon spicules:** They are long, rod-like, straight, one rayed spicules found in large numbers in a circular manner around the osculum. They are also known as monoradiate spicules. When they are pear or club-shaped, they are termed oxeote spicules. Such spicules project from the outer surface of the body and also lie inside the radial canals. (Fig. 5.6)
- ii. **Tri-axon spicules:** They are also called tri-radiate spicules. These numerous three rayed spicules are present along the radial canals with one ray pointed towards the distal ends of the canals. (Fig. 5.6)
- iii. **Tetra-axon spicules:** They are also known as tetraradiate spicules, possessing four rays. They occur along with the tri-radiate spicules in the gastral cortex surrounding the gastral cavity.
- iv. **T-shaped spicules:** They are rarely found.

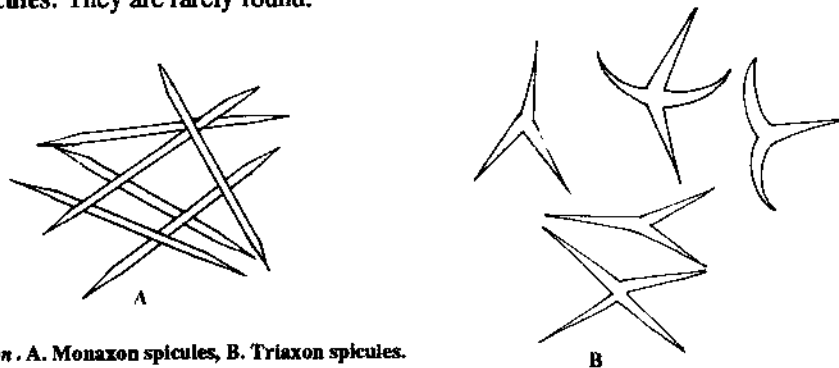

Fig. 5.6. Spicules in *Sycon*. A. Monaxon spicules, B. Triaxon spicules.

5.7 CANAL SYSTEM

Canal system is characteristic feature of all sponges and is of considerable physiological importance. It is also known as aquiferous system.

Sponges are sessile in nature and as such depend exclusively on the water current that enters through ostia and exits through osculum. While passing through various canals, the water current performs multifarious activities. As the efficiency of the life activities of sponges, largely depends upon the water current there seems to be a direct relation between the canal system and the water current.

The canal system of sycon consists of canals - **incurrent**, **radial**, and **excurrent**; openings - **ostia** and **osculum**; inter-canal apertures - **prosopyle** and **apopyle**; and the central **paragastric cavity**.

Incurrent canal: It is lined with flattened ectodermal pinacocytes. The outer ends of the canal are slightly dilated while the inner ends are narrow and terminate blindly towards the paragastric cavity. A thin pore membrane, perforated by two or three minute ostia, over the outer dilation.

Radial canal: It is also known as flagellated canal. It lies transversely between every two incurrent canals. It is lined with choanocytes. On the inner side it is connected with the paragastric cavity, where as its outer end terminates blindly. The radial and the incurrent canals are interconnected by short narrow channels called the prosopyles. Each prosopyle is perforated by a single tubular cell, the porocyte.

Excurrent canal: It is a short wide passage, lined with flat ectodermal pinacocytes. The radial canal opens into the paragastric cavity through the excurrent canal by central rounded, contractile aperture called the **apopyle**.

Paragastric cavity: It is central spongocoel, into which opens the excurrent canal. It is lined with flat epithelial cells resembling the pinacocytes. The paragastric cavity opens to the exterior by the osculum.

Course of water current: The sea water enters into the body of the sycon through the minute dermal ostia which opens into the incurrent canal. From here the water passes on to the radial canal through narrow passages called the prosopyles. Now the water current makes its entry into the excurrent canal which is guarded by a contractile aperture - the apopyle. From the excurrent canal the water fills the central spongocoel from where it finally leaves the body through the osculum, the contracting and expanding of which controls the rate of flow, even stopping it altogether. Water current — dermal ostia - incurrent canal - prosopyles - radial canal - apopyle - excurrent canal - spongocoel - osculum - outside.

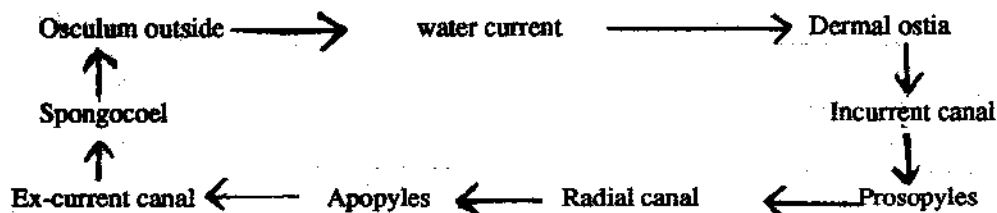

Advantages of canal system: Canal system is of great significance in sponges. The continuous and uninterrupted flow of water current in the porous body of the sponge is responsible for many vital physiological processes.

Different advantages, uses and functions of the canal system are as follows:

- i. The water current brings in oxygen and food.
- ii. It also keeps the sperms and egg moving in and out.
- iii. It removes nitrogenous wastes and carbon dioxide.
- v. It brings out the larval stage, the amphiblastula, which ultimately swims away.

It has been estimated that a sponge of 10 cm long and 1 cm wide consists of about 2,250,000 radial canals or flagellated chambers and pumps 22.5 litres of water per day through its body.

5.8 REPRODUCTION

Sycon reproduces both asexually and sexually

5.8.1 Asexual reproduction: It takes place by regeneration and budding.

Regeneration: Regeneration is the process of replacement and recovery of parts lost by damage or injury. If a sponge is teared or cut so as to separate the cells from one another, the cells tend to come together slowly and form a young sponge again.

Budding: Budding is the common method of asexual reproduction which takes place by external budding. Masses of archaeocytes migrate and form an outgrowth called a bud, which arises from the base of the sponge and acquires an osculum at the top. It may either become free and form a new sponge, or remain attached to the parent sponge and add to its size.

5.8.2 Sexual reproduction: Sexual reproduction takes place by sex cells - sperms and ova. Sycon is **Hermaphrodite** and **Protogynous** i.e. female gametes mature earlier than the male gametes. Special sex organs, testis, and ovaries, are absent. The sex cells arise from special amoebocytes, the choanocytes and the archaeocytes.

Sperms: The sperm mother cells or spermatocytes arise from amoebocytes which repeatedly divide. A **spermatogonium** is surrounded by a cover and divides two or three times to form **spermatocytes**, which develop into sperms. A mature sperm is small with an oval or rounded or pear shaped nucleated head and a long vibratile tail. They are carried along with a current of water into a flagellated chamber of another sycon. (Fig. 5.7.A)

Ova: The egg mother cells are amoeboid and wander through the mesenchyme to the base of the choanocyte layer in search of nutritive cells. They increase their size by receiving nutriment and then undergoes meiotic division to develop into an ovum. (Fig. 5.7 B). A mature ovum is large, round with a prominent nucleus. It lies in the wall of the radial canal. (Fig. 5.7.B).

Fertilization: Fertilization is the union of the male gamete, sperms, and the female gamete, ovum. It results into a zygote. Fertilization is internal. The mature sperms escape outside with the current of water. They enter the body of another sponge alongwith the incoming water current and reach the radial canals. Here, the sperms enters a wandering amoebocyte or choanocyte called a nurse cell, loses tail and get covered. The wandering choanocytes now carries the sperms to the oocyte. The sperm penetrates and fuses with the egg, completing the fertilization. It results into the formation of the zygote which now gets enclosed in a broad capsule formed by lining of the neighbouring amoebocytes. (Fig. 5.7. C).

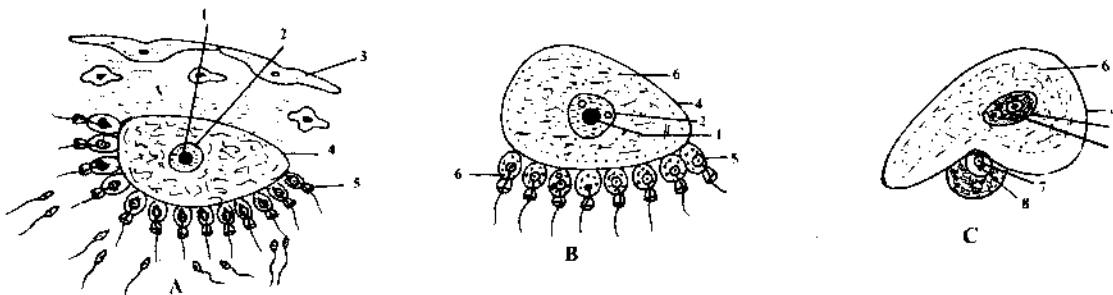

Fig. 5.7. Gametes and fertilization in *SYCON*. A. An Egg in the radial canal. B. Sperm internal in the flagellated cell. C. Nurse cell carrying the sperm for fertilization. 1. Nucleolus 2. Nucleus 3. Pinacocyte 4. Ovum 5. Choanocyte 6. cytoplasm 7. Sperm 8. Choanocyte (nurse cell).

5.9 DEVELOPMENT

Development is the series of events occurring in an organism during the changes from the fertilised egg to the adult stage. In all metazoan animals it commences with the division of the zygote, which repeatedly divides along definite plans at right angles to one another, forming cells in the geometrical ratio i.e. 2, 4, 8, 16, 32, 64 ... (Fig. 5.8).

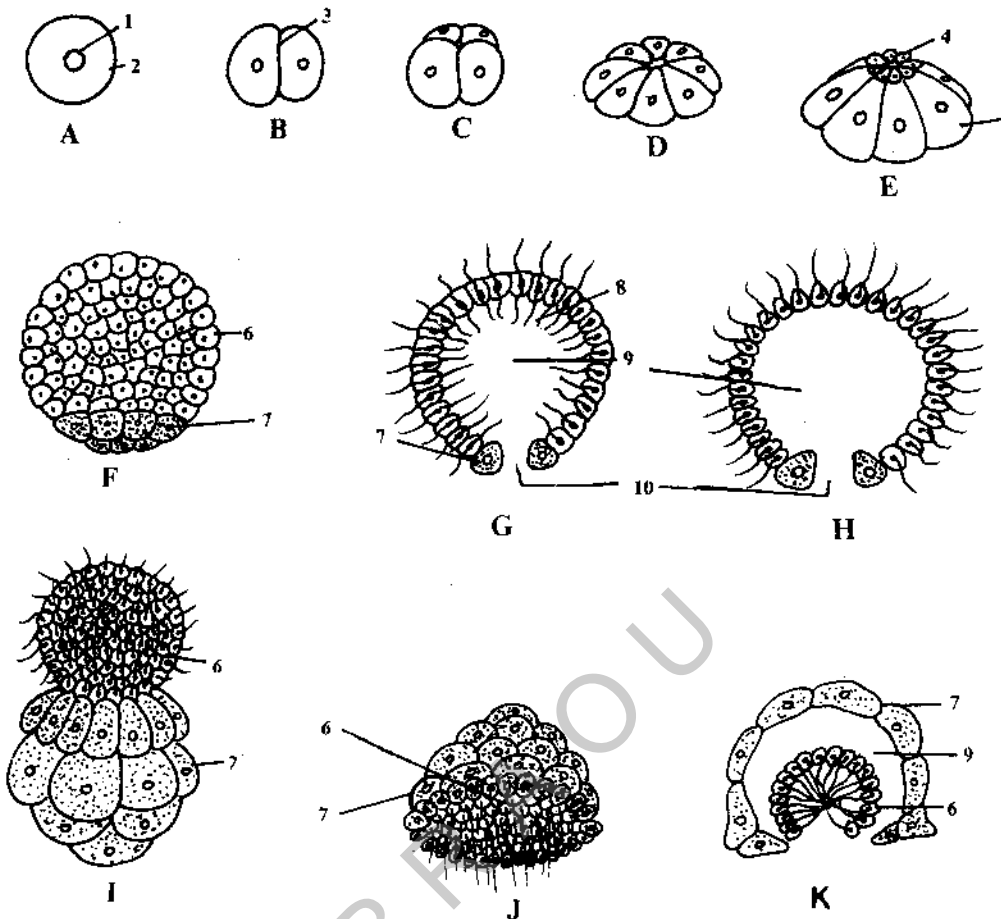

Fig. 5.8 Development of *Sycon*. A. Zygote. B. Two celled stage. C. Four celled stage. D. Eight celled stage. E. Sixteen celled stage. F. Blastula. G. Stomoblastula. H.V.S. of Stomoblastula after inversion. I. Amphiblastula. J. Gastrula formation by invagination. K. Fixed gastrula (L.S.) 1. Nucleus 2. Cytoplasm 3. Cleavage 4. Small micromeres 5. Large macromeres 6. Flagellated micromeres 7. Granular macromeres 8. Flagella 9. Blastocoel 10. Blastopore.

The early stages of development proceed in the radial canal.

i) **Cleavage:** The zygote undergoes segmentation or cleavage which is **Holoblastic**. The first three divisions are vertical producing eight cells or **blastomeres**. It is followed by a horizontal division, slightly towards the anterior end. Sixteen cells are resulted, of which eight are lower and larger called **Macromeres** and eight are upper and smaller, the **Micromeres**. The macromeres form the dermal layer, whereas the micromeres are destined to become the choanocytes. The embryo appears to be flattened disc-like. A cavity now appears in the centre called the **blastocoel**. The embryo is now known as **blastula**.

ii) **Stomoblastula:** The small micromeres multiply rapidly, become elongated and acquire flagella from the inner ends towards the gastrocoel. The macromeres do not divide but become granular. In the centre of the group of macromeres an opening appears that functions as a mouth. The embryo ingests adjoining choanocytes. This embryonic stage is called the **stomoblastula**. The embryo is essentially a blastula but with internally directed flagella and a closed mouth.

iii) **Amphiblastula:** The embryo now undergoes a remarkable process of inversion which is not met in any other Metazoa. The process begins with the reopening of the mouth, which enlarges to expose the flagellated cells now directing outwards. Now, the macromeres slowly multiply and spread on all sides. The mouth of the larva closes and the embryo becomes elongated. This free swimming flagellated embryonic stage is called **Amphiblastula**. It externally and internally differs from the adult, which is immobile.

ILLUSTRATION OF THE LIFE CYCLE

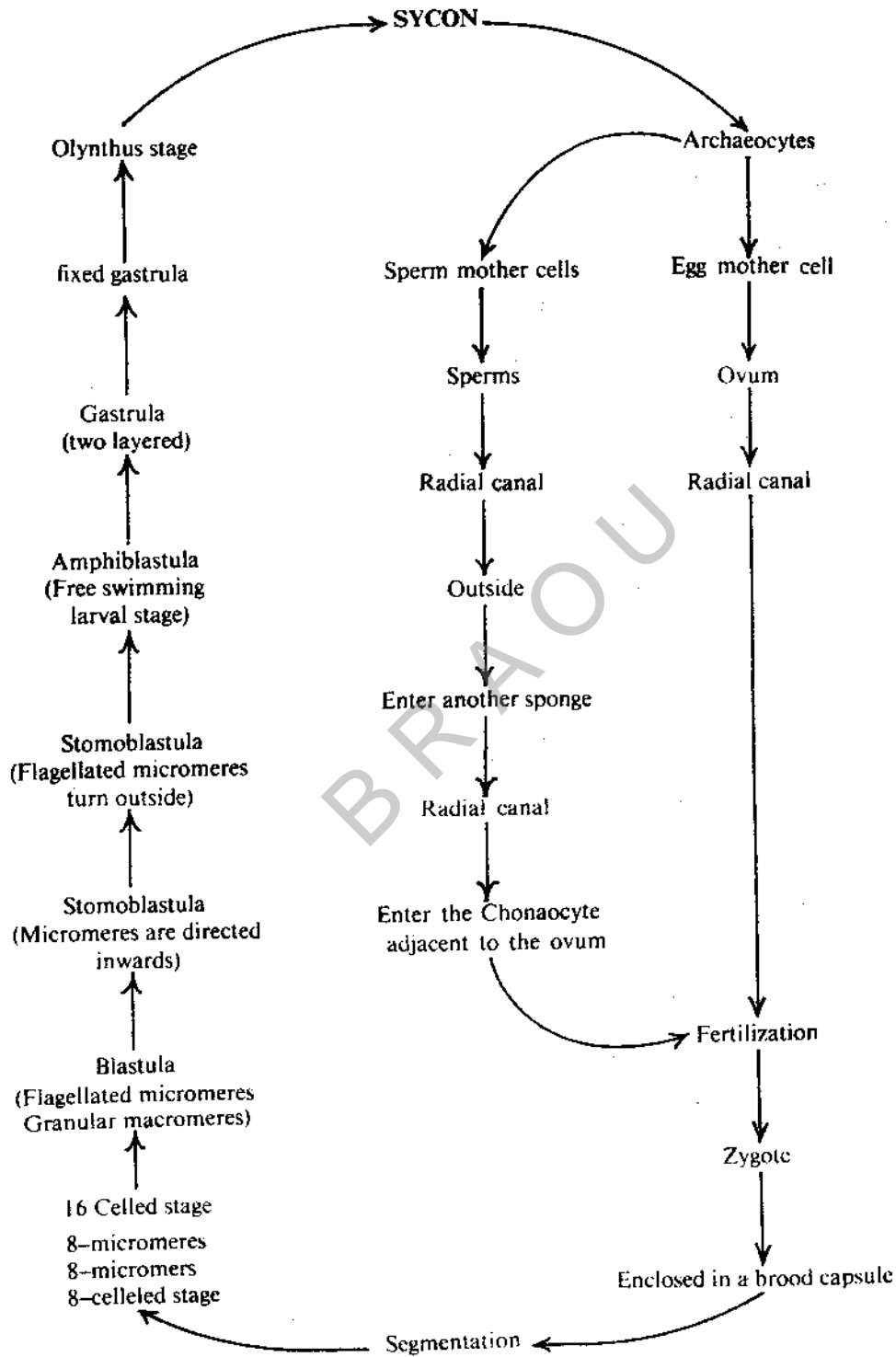

Until this stage the embryo was found in the mesenchyme below the choanocyte layer of the sponge. Now brood capsule ruptures, the larva gets detached and enters the radial canal, and finally comes out of the parent body along with the outgoing water current. It swims actively and marks the freeswimming ciliated larval stage of the life cycle of *Sycon*.

iv) **Gastrulation:** The amphiblastula larva now swims for sometimes with the flagellar end directed forward. It then settles down by the anterior end and undergoes further development. The flagellated cells invaginate and are overgrown by large granular cells. The embryo now becomes two layered, with a outer wall of non-flagellated cells and an inner layer of flagellated cells. This process is known as gastrulation and the diploblastic larva is called a gastrula.

Metamorphosis:

Metamorphosis is the phenomenon or structural change or transformation from a larval to an adult form, especially in animals where the larva is morphologically and anatomically different from the adult.

The larva elongates and becomes cylindrical and develops an osculum at its free distal end. Small perforations appear on the sides of the cylinder. The outer non-flagellated granular cells give rise to the dermal layer, the pinacocytes; while the inner flagellated cells form choanocytes and the various amoebocytes. This stage which resembles a simple *Leucosolenia* like sponge, is called olynthus stage.

Check Your Progress

1. Body wall of *Sycon* consists of two cellular layers namely.....and.....
2. The course of water current through the canal system starting from Ostia leads into
3. Regeneration and budding are common methods of.....reproduction.
4.larva is produced by *Sycon* during reproduction.

5.10 SUMMARY

Phylum Porifera comprises 'Sponges' found in the sea and the fresh water. They are lowly multicellular and sessile animals. Body traversed with many pores meant for the passage of water, which performs various body functions. Skeleton of spicules. Different physiological functions carried out by different types of cells in collaboration with the water current reproduction both asexual and sexual. Sponge is a sessile, calcareous marine sponge, Diploblastic, many amoebocytes in the mesogloea. Skeleton of different types of spicules. Physiological activities accomplished by the current of water flowing in the canals - constituting a canal system. Asexual reproduction by regeneration and budding. Sexual reproduction by sperms and eggs. Fertilization and development in situ. Free swimming larval stage.

5.11 CHECK YOUR PROGRESS - MODEL ANSWERS

1. dermal, gastral
2. Incurrent, prosopyle, radial canal, apopyle, excurrent canal, spongocoel, osculum.
3. asexual
4. amphiblastula, sexual

5.12 MODEL EXAMINATION QUESTIONS

- I. Answer the following in about 30 lines.
 1. Describe the general characters of Porifera.
 2. Give an outline classification of phylum Porifera, upto the levels of classes, with characters and examples of each class.

3. Describe the internal structure of *sycon*, elucidating of the various types of cells and their functions.
4. Explain the canal system of *Sycon* and enumerate its advantages.
5. Give an account of the sexual reproduction and development of *Sycon*.

II. Answer the following in about 10 lines

1. Skeleton of sponges
2. Asexual reproduction in *Sycon*

5.13 RECOMMENDED BOOKS

- | | |
|--|--|
| 1. Agarwal V.P.
Dalela R.C. | : A text book on Invertebrate Zoology
: Jai Prakash Nath & Co. Meerut |
| 2. Blackwelder R.E. | : Taxonomy, John Wiley & Sons, Inc. New York |
| 3. Chandlar | : Parasitology |
| Chatterji - | : Medical and Veterinary Parasitology |
| 4. Dalela, R.C. | : Animal Taxonomy and Museuiology, |
| Sharma, R.S. | : Jai Prakashnath & Co., Meerut |
| 5. Dhama P.S.
Dhama | : PROTOZOA - Phylum series Volume - I
: R. Chand & Co. Publishers, New York |
| 6. Dhama P.S.
DAMI J.K. | : Phylum series Volume-I., PORIFERA
: R. Chand & Co. Publishers, New Delhi |
| 7. Gordon,
Malcolms, et al | : Zoology, Collier Macmillian International Editions |
| 8. Jordan E.L.
Varma P.S. | : Invertebrate Zoology
: S. Chandra & Co. |
| 9. Kotpal R.L. | : Protozoa, Phylum Series, Rastogi Publications, Meerut |
| 10. Kotpal R.L.
Kotpal R.L.
Ketrpal
Agarwal | : Porifera, Rostogi Publications, Meerut
: Invertebrate Zoology.
: Rastogi Publications
: Meerut |
| 11. Majhpuria | : A Text Book on Invertebrate Zoology |
| 12. Parker, T.J. & Haswell,
W.A. | : Text Book of Zoology - Invertebrates
: (Edited by A.J. Marshall & W.D. Williams)
English language Book Society and Macmillan |
| 13. Prasad S.N. | : A Text Book of Invertebrate Zoology
Kitab Mahal Publications. Allahabad |
| 14. Rastogi, Veer Bala | : A Text Book of Invertebrate Zoology
Jai Prakash Nath & Co., Meerut |
| 15. Saxena, M.M. | : A Text Book of Invertebrate Zoology
Prakasham Kendra, Lucknow |
| 16. Simpson, G.G. | : Principles of Animals taxonomy
Colombia University Press, New York |
| 17. Singer, Charles | : A History of Biology
Abelard - Schuman, London, New York |
| 18. Siva Sastry, T.V.
Narasimha Rao K. | : B.Sc., Zoology (Invertebrate)
: Commercial Literature Co., Guntur |
| 19. Storer, Tracy I. &
Usinger, Robert L. | : General Zoology
: Mc Graw-Hill Book Company |
| 20. Vishwanath | : A Text Book of Invertebrate Zoology |
| 21. Hyman L.H. | : Invertebrate Vol. I |

5.14 GLOSSARY

- Amoeboid cells : Cells with amoeboid properties, i.e. moving and feeding by the action of pseudopodia.

Bacteria	: Tiny, microscopic and single celled organisms
Colonial	: Collection of organisms living together
Connective tissue	: Tissues which fills spaces and holds the organs together in the animal body.
Contractile power	: Power of contraction and dilation
Crustacean	: A large and varied group of arthropods, mostly aquatic, such as shrimps, prawns and crabs
Diffusion	: Spreading or scattering of liquids and gases from one medium to the other
Diploblastic	: Having two distinct germ layers i.e. ectoderm and endoderm
Epithelial cells	: Cells of the outer layer of epidermis
Enzyme	: (G.K. en: in: zyme: leaven) A chemical substance which accelerates a chemical process.
Gelatinous matrix	: The ground substance of a tissue; a non-living substance secreted by the cells and occupying the space between them.
Hexactinal spicules	: Six rayed spicules.
Holoblastic	: Complete cleavage of a fertilized ovum
Holozoic	: Feeding entirely on organic substances; The feeding habit of animals.
Hermaphrodite	: (G.K. Hermaphroditos: combining both sexes) Any organism possessing both male and female reproductive organs.
Intracellular	: Within the cell
Meiosis or meiotic division	: A process of cell division whereby the number of chromosomes is halved (G.K. meia: beyond; morphe: form)
Metamorphosis	: A rapid and complete transformation from a larval to an adult form.
Metazoa	: Multicellular animals, in which numerous differentiated cells in the tissues are grouped in functional organs and systems.
Mollusca	: Softbodied unsegmented animals having a calcareous shell.
Mucus	: A shiny solution of mucin secreted by mucous gland of mucous membrane
Multicellular	: (L. multus: many; cellar; cell) Consisting of more than one cell; many celled.
Nitrogenous waste	: Excretory matters which are rich in nitrogen, like urea
Organ	: (G.K. organon: implement) A differentiated part of organism adopted for a definite function
Parabasal body	: A secondary basal granule, synonym of blepharoplast
Plankton	: Microscopic animal and plant which generally floats and drifts near the surface of a lake, river or sea.
Radially symmetrical or Radial symmetry	: A symmetry in which the similar parts are arranged round a median vertical axis.
Rhizoplast	: Protoplasmic thread connecting the basal granule of a flagellum with the nucleus or with the parabasal body in certain protozoa.
Sessile	: (L. Sedere: to sit) Animals attached by a broad base, immoveable.
Substratum	: A particular substance or group of substances upon which sessile animal is found attached.
Symmetry	: A harmonious correspondence of parts.
Tissue	: (F. tissue: woven) group of similar or dissimilar cells, performing a specific kind of function
Vibratile tail	: Tail which capable of moving backwards and forwards

UNIT - 6 CNIDARIA - GENERAL CHARACTERS AND CLASSIFICATION

Contents

- 6.1 Objectives
- 6.2 Introduction
- 6.3 General Characters
 - 6.3.1 Class - Hydrozoa
 - 6.3.2 Class - Scyphozoa
 - 6.3.3 Class - Anthozoa
- 6.4 Summary
- 6.5 Check Your Progress - Model Answers
- 6.6 Model Examination Questions

6.1 OBJECTIVES

In this unit we deal with the general characters and diversity existing in Phylum cnidaria and concept of diploblastic condition is discussed. Classification and examples are given. At the end of this unit you will be able to explain the diploblastic condition, development of internal cavity for digestion which opens outside through mouth.

6.2 INTRODUCTION

Previously cnidaria and ctenophora were included in the phylum coelenterata. The name phylum coelenterata was given due to the presence of coelenteron. Due to the absence of nematocysts in ctenophora, this group is separated from cnidaria which has nematocysts and both have been made as separate phyla. All cnidarians are radially symmetrical which exhibit two structural types - a sessile type, the polyp and a freeswimming form, the medusa.

6.3 GENERAL CHARACTERS

1. Cnidaria are the **multicellular** animals like sponges.
2. The members of this phylum are distributed throughout the world.
3. All are marine except a few fresh water forms
4. The body is composed of two cellular layers i.e. ectoderm and endoderm, hence they are called **diploblastic** animals.
5. These exist in two forms: The **polyp**-asexual zooid and **medusa**-sexual zooid.
6. They usually exhibit radial symmetry in adult stage.
7. There is only one mouth which also functions as anus.
8. Digestion is both intracellular and extracellular.
9. Nervous system is primitive consisting of diffuse network of nerve cells.
10. Sensory organs may be simple or complicated. Some with eye spots or *statocysts*.
11. Reproduction is both asexual by budding and sexual by ova and sperms. The phylum cnidaria comprises of three classes. They are: 1. **Hydrozoa**, 2. **Scyphozoa**, 3. **Anthozoa** or **Actinozoa**.

6.3.1 Class: Hydrozoa

1. Mostly colonial and marine (*Obelia*) a few solitary and fresh water (*Hydra*), sessile or free.
2. Body radially symmetrical

3. Body wall diploblastic, consisting of ectoderm and endoderm separated by a non-cellular gelatinous mesoglea.
4. The epidermis consists of epithelio-muscular cells, interstitial cells, sensory cells, gland cells and nerve cells.
5. Some of the interstitial cells give rise to characteristic organs of offence and defence called stinging cells or **nematocysts**.
6. The endoderm consists of flagellate or amoeboid cells, gland cells and epithelio-muscular cells.
7. The digestive cavity communicates directly to the exterior by a single aperture or mouth.
8. The gastro-vascular system is simple, without stomodaeum and not divided by vertical partitions and mesenteries.
9. There are two types of zooids in the colony. They are - 1. **polyps** or **gastrozooids**, 2. **blastostyles** or **gonozooids**.
10. True velum is present.
11. Sexual cells are generally ectodermal in origin and discharged externally.
12. The colony develops only by the asexual process of budding, but certain of its buds, the medusae develop gonads and from their fertilised eggs new hydrozoan colonies arise.
13. In most cases the only skeleton of supporting structure is the outer horny **perisarc**. There are some forms in which the inner *coenosarc* secretes, a skeleton of calcium carbonate forming a massive stony structure or **coral**.
14. There are colonial forms which instead of remaining fixed, swim or float freely on the surface of ocean. Such pelagic forms are always found to exhibit a remarkable degrees of **polymorphism**, having the zooids of various forms and performing diverse functions.
15. The larva is ciliated planula. e.g. *Obelia* (Fig. 6.1), *Physalia* (Fig. 6.2 A), *Millepora* (Fig. 6.2 B).

6.3.2 Class: Scyphozoa

1. These are **medusoid** cnidaria.
2. These are purely marine forms and the majority are pelagic i.e. they swim freely in the ocean.
3. Nearly all are free-swimming in the adult state. Some however, like on coral reefs or mud banks and or found resting in an inverted portion on the ex-umbrellar surface.
4. Many of the scyphozoa are semi-transparent and glassy, but often with brilliantly coloured gonads, tentacles or radial canals.
5. In many cases the umbrella or oral arms etc. are highly coloured.
6. Polyp phase absent or reduced, represented by a small and solitary non-sexual portion called **Scyphistoma**.
7. **Scyphistoma** produces, medusae directly or by a process of terminal budding or transverse fission called **strobilation**.
8. Medusa phase is dominant. Medusae are large, bell and umbrella shaped and free swimming or attached by an aboral stalk.
9. Mesoglea is usually cellular.
10. Gastro-vascular system without stomodaeum and may or may not be divided by **sesepta** into four inter-radial pouches.
11. These lack a true velum but usually possess sense organs in the form of hollow sense clubs or tentaculocysts.
12. In the majority, however, nothing is known of the life-history, the process of development has been worked out only in few cases.

E.g., *Aurelia*, (Fig. 6.2 C), *Rhizostoma*.

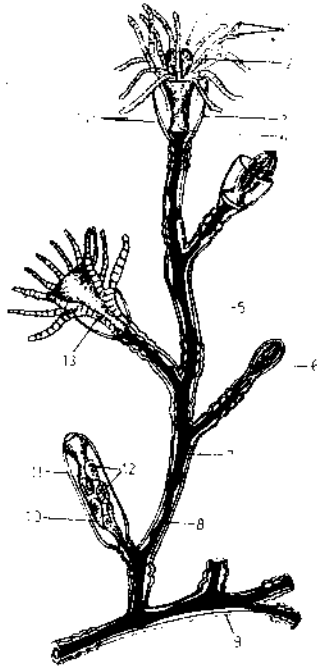

Fig. 6.1. *Obelia* colony. 1. Tentacles. 2. Manubrium. 3. Hydrotheca. 4. Shelf. 5. Perisarc. 6. Bud. 7. Coenosarc. 8. Hydrocaulus. 9. Hydrotheca. 10. Blastostyle. 11. Gonotheca. 12. Medusae buds. 13. Mesogloa. 14. Polyp.

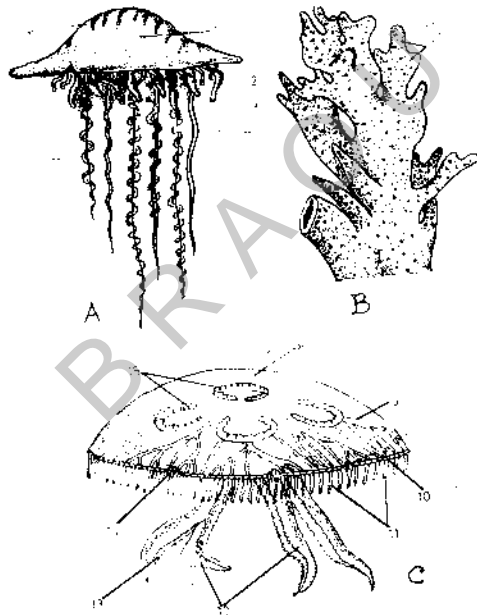

Fig. 6.2 A. *Physalia*. B. *Millipora*. C. *Aurelia*. 1. Pneumatophore. 2. Gastrozoid. 3. Gonozoid. 4. Dactylozoid. 5. Tentacles bearing nematocyst. 6. Sail or crest. 7. Gastropores. 8. Ex-umbrellar surface. 9. Inter radial canal. 10. Circular canal. 11. Marginal tentacles. 12. Oral arms. 13. Groove. 14. Marginal lappet. 15. Gonads.

6.3.3 Class: Anthozoa

1. These exist in the polyp form.
2. These are solitary or colonial, exclusively marine, found fixed to the substratum.
3. Medusa stage is not known in this class.
4. Gastro-vascular cavity of Anthozoa differs from the Hydrozoan and many scyphozoan polyps in having stomodaeum and radiating mesenteries or vertical radiating partitions. The

- mesenteries bear coiled mesenteric filaments or gastric filaments.
5. The mesoglea is well-developed with fibrous connective tissue.
 6. The muscular system is well developed. It consists of the processes of epithelio-muscular cells in both the ectoderm and endoderm.
 7. Some members of this class do not have hard parts or skeletal structures. Majority possesses a skeleton formed either of carbonate of lime or a horn like or chitinoid material developed from the ectoderm.
 8. As in scyphozoa budding and a kind of transverse fission like strobilation occurs.
 9. In most members of this class extensive processes of a sexual reproduction takes place giving rise to colonies of various forms.
 10. The gonads are developed in the mesenteries. The sex cells are lodged in the endoderm. The ripe sexual products are discharged into the coelenteron.
 11. The fertilized egg develops into a planula. Planula after a short free existence settles down and undergoes metamorphosis into adult.

e.g. *Pennatula* (Sea-pen), *Corallium* (Red coral), *Acyonium* (Deadman's finger) (Fig. 6.3. A-C)

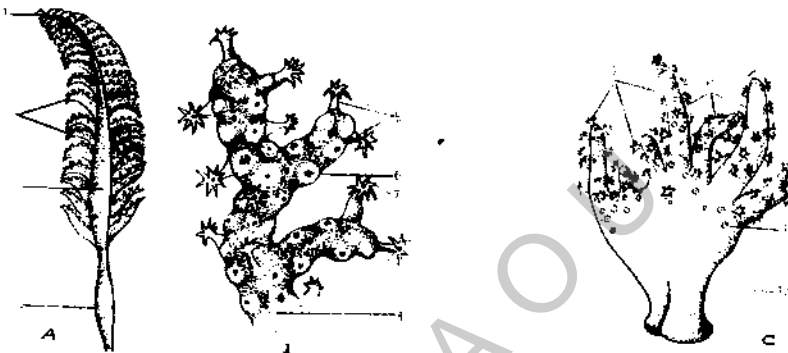

Fig. 6.3. A. *Pennatula*. B. *Corallium*. C. *Acyonium*. 1. Axial polyp. 2. Lateral branches. 3. Rachis bearing siphonozoids. 4. Peduncle. 5. Anthrocodia. 6. Completely retracted polyps. 7. Pinnate tentacles. 8. Coenenchyme. 9. Expanded lobes. 10. Digitate branches. 11. Contracted polyps. 12. Stalk.

Check Your progress

1. Scyphozoans are forms
2. Medusae are zooids, which produce sperms and ova.
3. In corals dominant form is

6.4 SUMMARY

The cnidaria are the diploblastic, radially symmetrical metazoans, which exist in two forms polyp and medusa. There is a single body cavity, coelenteron or gastrovascular cavity. Highly specialised organs of offense and defence called nematocysts are present. Cnidaria has three classes. Hydrozoa, Scyphozoa and Anthozoa. General characters of classes and examples have been discussed.

6.5 CHECK YOUR PROGRESS - MODEL ANSWERS

1. Medusoid

2. Sexual
3. Polyp.

6.6. MODEL EXAMINATION QUESTIONS

I. Answer the following in about 30 lines.

1. Mention the different classes of phylum cnidaria and give an account of the characters of scyphozoa.
2. Describe the general characters of phylum cnidaria. Add a note on the important characteristic features of hydrozoa.

II. Answer the following in about 10 lines.

1. General characters of the class Anthozoa.

BRAOU

UNIT-7 OBELIA

Contents

- 7.1 Objectives
- 7.2 Introduction
- 7.3 General Structure
 - 7.3.1 Polyp or hydranth
 - 7.3.2 Gonangium or Blastostyle
 - 7.3.3 Medusa
- 7.4 Life - History
- 7.5 Metagenesis
- 7.6 Comparison of Polyp and Medusa
- 7.7 Summary
- 7.8 Check Your Progress - Model Answers.
- 7.9 Model Examination Questions.
- 7.10 Glossary.

7.1 OBJECTIVES

In this unit we shall discuss *Obelia* as one example of Phylum Cnidaria. Its structure and life cycle are also discussed in detail. At the end you will be able to explain not only the structural peculiarities of both polyp and medusa form but also the alternation of generations.

7.2 INTRODUCTION

Obelia, a marine cnidarian exhibits a free swimming medusoid generation as well as a sessile hydroid stage. It illustrates a phenomenon known as metagenesis — the regular alternation of a sexually and asexually reproducing generations.

7.3 GENERAL STRUCTURE

Obelia is a typical small, branching colonial and marine hydroid, cosmopolitan in distribution (Fig. 6.1).

The colony of *Obelia* looks like a delicate, mossy or fur like growth, whitish or light-brown in colour. It is one to several inches in height. The basal or horizontal portion of a colony is like a root or creeping stem. By this, the colony attaches to the substratum. This creeping stem or **hydrorhiza** gives off several, slender, upright or vertical threads called **hydrocauli**. Each hydrocaulus forms the main stem or axis of the colony. It branches in an alternate manner and the lateral branches may sometimes branch again. Some of these ultimate branches end in polyps and some others end in cylindrical bodies called **blastostyles**.

The stems and the zooids are made of a living hollow cellular tube, the **coenosarc**. The coenosarc consists of an external layer of **ectoderm** and an inner layer of **endoderm** with an intermediate non-cellular **mesoglea**. The *Obelia* colony exhibiting two types of zooids is thus **dimorphic**.

The blastostyles give rise to several, little saucer-shaped lateral off-shoots called the **medusae buds**, each of which finally develops into a free-swimming sexual zooids or medusae. The colony thus becomes **trimorphic**. The *obelia* colony is a good example of **polymorphism** due to the polymorphic nature of its individuals (having several structurally and functionally different individuals is called polymorphism).

7.3.1 Polyp or Hydranth

It is somewhat like a miniature *Hydra*. Under the microscope it looks like a cylindrical or conical hollow sac of yellowish colour. Basally it is connected by a hollow stalk with hydrocaulus, while its distal end is produced into a conical elevation, the **hypostome** or **manubrium**. The apex of the manubrium bears a terminal aperture, called mouth. Around the base of the manubrium are arranged tentacles. The body and manubrium of polyp enclose a spacious **gastro-vascular cavity**, or **coelenteron**. The body wall of hydranth or polyp consists of two layers, **ectoderm** and **endoderm** with noncellular **mesoglea** in between (Fig. 7.1).

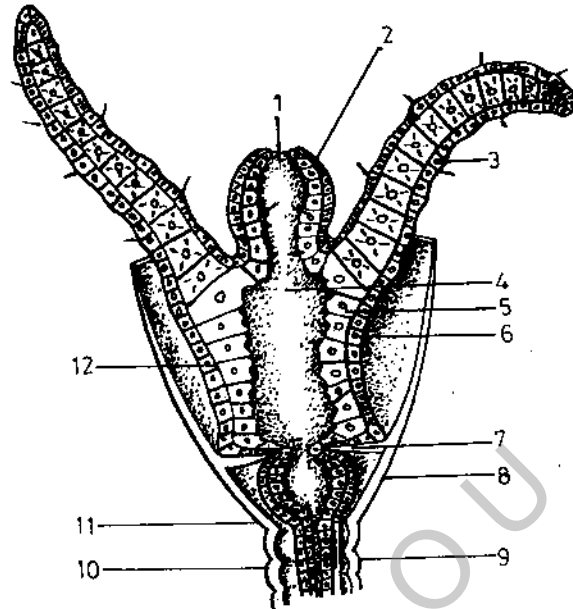

Fig. 7.1. *Obelia* Polyp (v.s) 1. Mouth. 2. Hypostome. 3. Tentacle. 4. Coelenterom. 5. Endoderm. 6. Ectoderm. 7. Hydrotheca. 9. Perisarcial annuli. 10. Coenosarc. 11. Perisarc. 12. Mesogloea.

The perisarc covering the polyp expands to form a loose conical cup, called **hydrotheca** which is transparent and colourless. When irritated, the polyp undergoes a sudden contraction and withdraws itself partly or wholly into the hydrotheca. Then the tentacles shorten and curl over the **manubrium**. The hydrotheca at its base is produced inwards into a perforated circular, ring-like horizontal **shelf** on which the base of the polyp rests. Through the central perforation of the shelf the basal disc of the polyp remains continuous with the **coenosarc** of the stem. The annular constrictions of the **perisarc** at the base of the polyp or the branch give a ringed appearance and permits swaying movements.

They are chiefly carnivorous and like *Hydra*. feed on small aquatic animals such as crustaceans, nematodes, worms etc. The prey is seized and taken to the mouth with the help of tentacles armed with **nematocysts**. The endodermal cells lining the gastrovascular cavity secrete digestive juices which disintegrate the food. Partly the food is digested in the cavity and partly inside the amoeboid cells which engulf the bits of food. Thus digestion is both extra and intracellular as in *Hydra*. The muscular contractions of the polyp and the beating of endodermal cells (cells which bear flagella) help in circulating the digested food throughout the colony to be absorbed by the cells of different layers. The mouth of a polyp serves for both **ingestion** and **egestion**, there being no anus.

7.3.2 Gonangium or Blastostyle.

A blastostyle is a simplified zooid without mouth and tentacles. It is a narrow, elongated hollow tube closed distally by a flattened disc. It is enclosed in a loose, glassy, vase-like capsule, called the

gonotheca. It produces asexually numerous small medusa buds (sexual zooids). When fully formed, the medusae detach, set free by the rupture of gonotheca at the distal end and swim away from the parent colony. Gonotheca, blastostyles and the medusa together form a **gonangium** (Fig. 7.2).

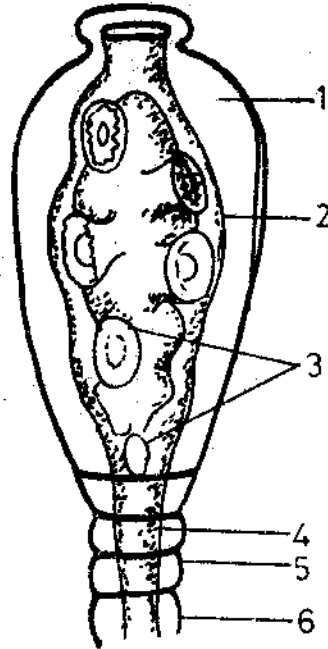

Fig. 7.2 *Obelia* A. Gonangium 1. Gonotheca. 2. Blastostyle. 3. Developing medusae buds. 4. Coenosarc. 5. Perisarc. 6. Stalk.

The cellular structure of polyps, blastostyles, medusa buds and coenosarc is similar to that of *Hydra*.

The ectoderm is thin and chiefly made of large, conical, columnar musculoepithelial cells with their bases outwards. Their narrow inner ends form the unstriped muscle fibres arranged longitudinally between the ectoderm and mesoglea. They serve for the rapid shortening of the body and tentacles. Interstitial cells are completely absent in the spaces between the inner ends of the epithelial cells. The ectoderm also contains stinging cells or nematocysts which serve as weapons of offense. The nematocysts originate from **nematoblasts** in the coenosarc or basal region of the polyp. The nematocysts of *Obelia* are basitrichous **isorhizas** having an oval capsule, a long thread open at the tip and bearing basal spines.

The endoderm consists chiefly of large, columnar, muscilonutritive cells. Their inner free ends can form pseudopodia to engulf and digest food particles. Sometimes the pseudopodia are replaced by long flagella which help in circulating the digested food. Among the musculo-nutritive cells gland cells are present. These secrete the digestive juices in the enteron.

7.3.3 Medusa

It is a modified zooid meant for sexual reproduction. It is solitary and free-swimming (Fig.7.3)

A fully formed medusa of *Obelia* is like a tiny umbrella, bell on shallow saucer. The convex outer surface of the umbrella is the **ex-umbrella** while the concave inner surface is **sub-umbrella**. The medusa bud was originally attached to the blastostyle by ex-umbrellar surface. From the centre of sub-umbrellar's surface hangs down a short hollow and quadrangular process known as the **manubrium**. At the distal free end of the manubrium is the four-sided mouth surrounded by four oral lobes. The rectangular mouth leads into **gastric cavity** or stomach. The basal part of the stomach leads into four narrow, delicate **radial canals** which are placed at equal distances from each other. Near the edge of the umbrella, the four radial canals open into a **circular canal** running

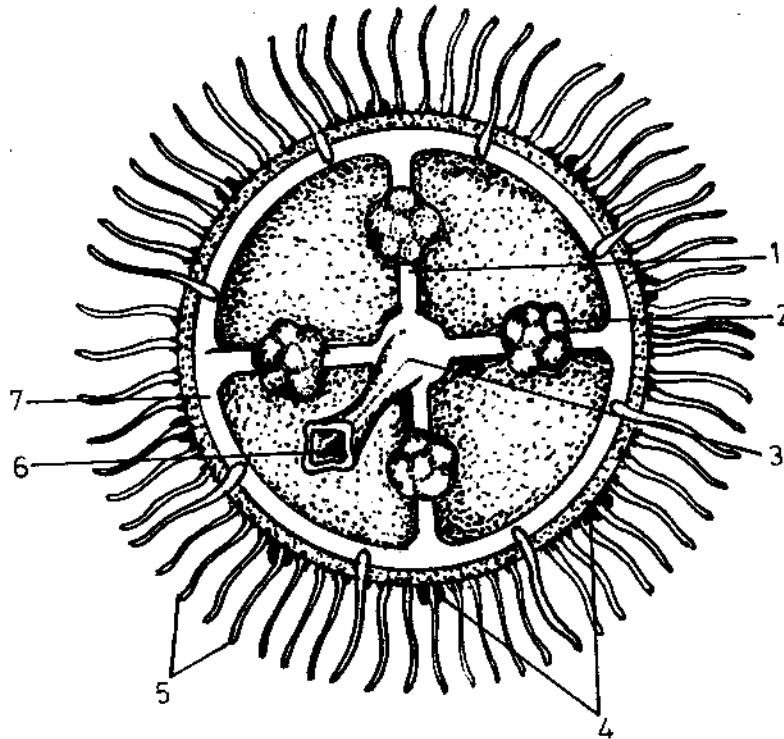

Fig. 7.3 *Obelia* Medusa in oral view. 1. Radial canal. 2. Gonad. 3. Manubrium. 4. Lithocytes. 5. Tentacles. 6. Mouth. 7. Circular canal.

parallel with and close to the margin. The edge of the umbrella is produced inwards into a narrow, rudimentary fold or shelf, called the *velum*. The medusae having a *velum* are called *craspedote*. The margin of the umbrella also bears numerous short tentacles which are highly contractile. The edge of the umbrella gives off tentacles which are sixteen in number in the newly born medusa but are more numerous in the adult. At the bases of eight of the tentacles are minute globular sacs, each containing a calcareous body. There are the marginal sense organs or *lithocysts*, concerned in the co-ordination of swimming movements.

7.4 LIFE - HISTORY

The male gametes or spermatozoa after maturation are liberated into water. They are carried by currents to the female gametes. There they fertilise the ova and form *zygote*. *Zygote* undergoes cleavage forming *blastula* and *gastrula*, finally giving rise to *planula larva*. The *planula larva* is a ciliated free swimming form. It has an elongated ovoid body. The outer layer of the body is composed of ciliated ectodermal cells and inner endodermal layer. The *planula* swims freely for a time and then settles down on a piece of timber or sea weed. It fixes itself by one end and becomes converted into a *hydrula* or simple polyp. It has a disc for attachment at its proximal end, a *manubrium* and a circle of tentacles at the distal end. Soon the *hydrula* gives out lateral buds. By a frequent repetition of this process, the *hydrula* become converted into the complex *Obelia* colony (Fig. 7.4).

7.5 METAGENESIS

The life-history of *Obelia* shows a regular alternation of the colonial hydroid and the solitary medusa. The hydroid colony is fixed and has no gonads. It reproduces asexually by budding giving rise to medusae. The medusae develop gonads and reproduce sexually by forming spermatozoa and ova. The eggs and spermatozoa after fertilisation form new *Obelia* colony. An asexual hydroid generation thus alternates with a sexual medusoid generation. This phenomenon is called

metagenesis, meaning that the life history of *Obelia* has two distinct phases - one asexual, the other sexual - which alternate regularly one after the other.

7.6 COMPARISON OF POLYP AND MEDUSA

POLYP	MEDUSA
1. Fixed by a basal stalk, rarely free.	1. Free-swimming without stalk.
2. Body cylindrical elongated.	2. Body saucer-shaped or umbrella-like.
3. Base attached below so that manubrium is directed upwards.	3. Base is above so that manubrium hangs downwards.
4. Tentacles are usually 24.	4. There are 16 tentacles in young medusa, numerous in adult.
5. Body-structure simple muscles and nervous system simple.	5. Body-structure complicated, muscles and nervous system more developed.
6. Velum is absent	6. Velum present around the margin of umbrella.
7. Mesoglea poorly developed.	7. Mesoglea enormously developed.
8. Sense organs are absent.	8. Bases of 8 radial tentacles possess marginal sense organs called lithocysts.
9. Coelenteron simple, without radial and circular canals.	9. Coelenteron represented by stomach, four radial canals and one circular canal.
10. Mouth circular.	10. Mouth rectangular.
11. Nutritive zooid, without gonads.	11. Reproductive zooid possessing 4 gonads on radial canals.
12. Reproduces asexually by budding.	12. Reproduces sexually by producing gametes

LIFE CYCLE IN OBELIA

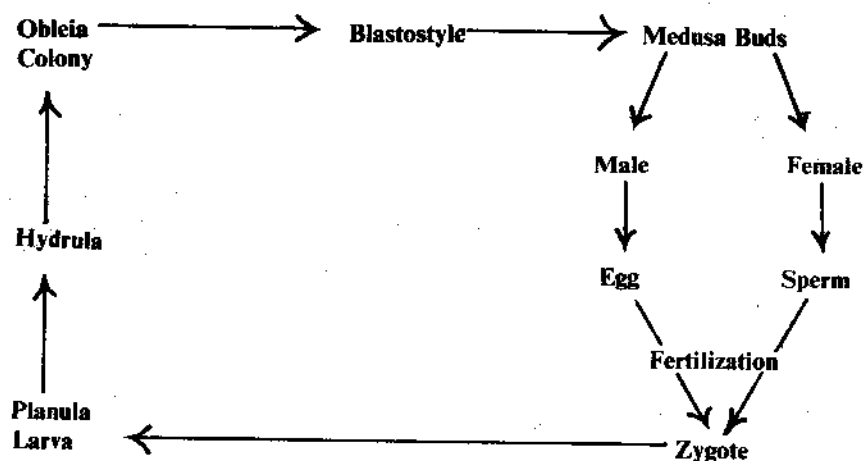

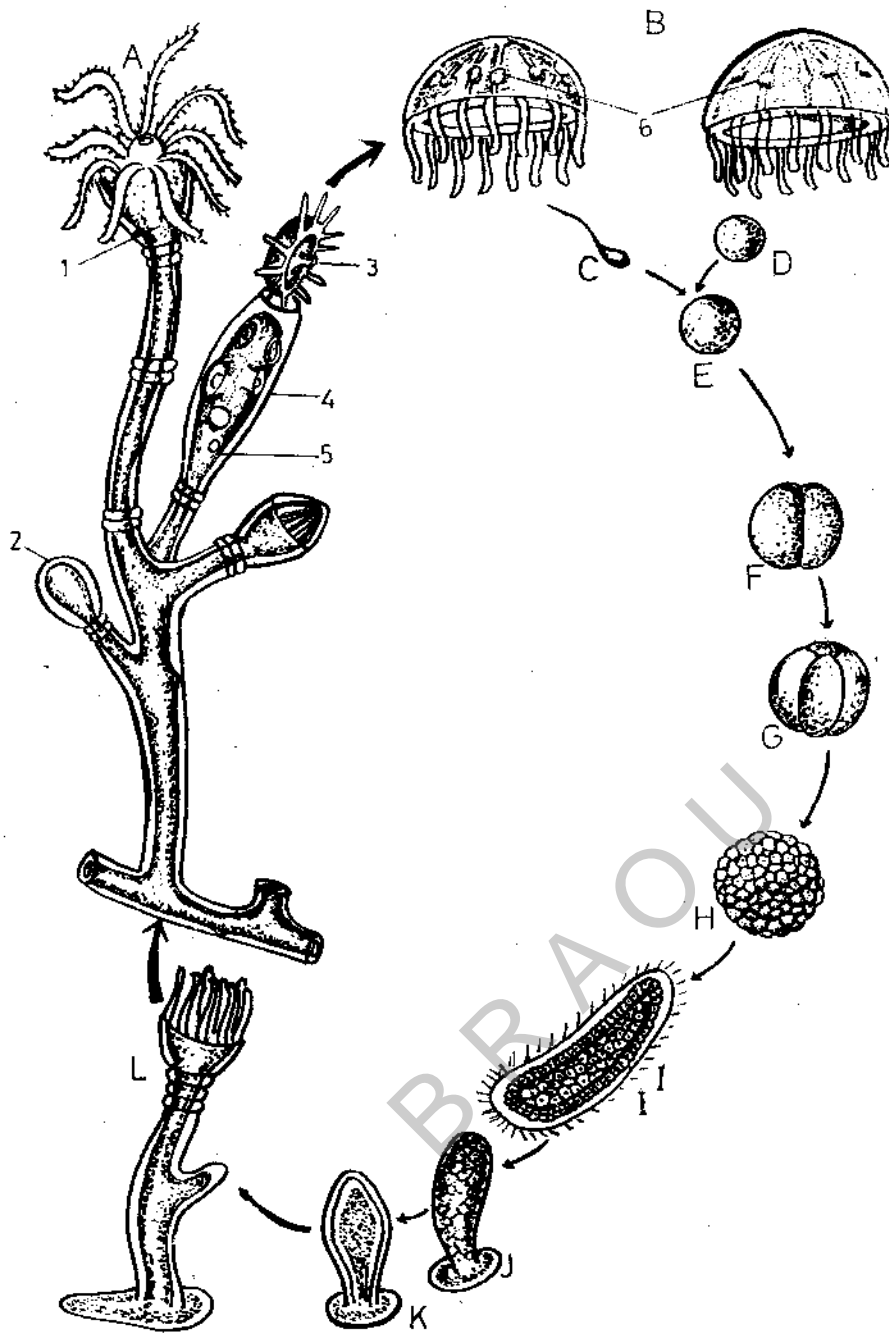

Fig. 7.4 Stages in the life cycle of *Obelia*. A. Asexual stage, sessile colony. B. Sexual stage, free swimming medusae C. Sperm. D. Ovum. E. Zygote. F, G. 2-cell stage. H. Blastula. I. Free swimming ciliated Planula larva. J. Planula settles down. K. Young Polyp. L. Hydrilla budding. 1. Polyp. 2. Bud. 3. Medusa escaping 4. Gonangium. 5. Blastostyle. 6. Gonads.

Check Your progress.

1. Trimorphic colony of *Obelia* consists of
2. In a polymorphic colony individuals are histologically but functionally
3. Metagenesis not only rejuvenates but also contributes to the of species.

7.7. SUMMARY

Obelia is a marine colonial hydroid. The colony is a trimorphic having three kinds of zooids i.e. polyp, blastostyle and medusa. These zooids are structurally and functionally different from each other. *Obelia* colony develops by the asexual process of budding. Some of its buds, the medusae develop gonads and gonads liberate sex cells into water sperms and ova unite and form fertilised egg. from which new *Obelia* colony arises. This is an example of metagenesis in which an asexual generation is followed by sexual generation.

7.8. CHECK YOUR PROGRESS — MODEL ANSWERS

1. Polyps, Blastostyles, Medusae.
2. Similar, different.
3. dispersal.

7.9 MODEL EXAMINATION QUESTIONS

I. Answer the following in about 30 lines.

1. Write briefly the structure of *Obelia* colony.
2. Write an account of life-cycle in *Obelia*. Add a note on metagenesis.
3. Mention the differences between Polyp and Medusa of *Obelia*.

II. Answer the following in about 10 lines.

1. Describe the structure of polyp.
2. Describe the structure of medusa.
3. Describe the structure of blastostyle.
4. Describe the process of nutrition in polyp.

7.10 GLOSSARY

Archenteron	: The central cavity of gastrula lined by endoderm representing the future digestive cavity of the adult
Blastopore	: Opening connecting archenteron of gastrula with outside represents the future mouth in some animals and future anus in others.
Blastula	: Stage in early animal development, when embryo is hollow or solid sphere of cells.
Cnidaria	: Cnidoblast possessing animals.
Cnidoblast	: Stinging cell characteristic of coelenterates contains nematocysts.
Cnidocil	: Spike of hair-trigger or cnidoblast serving in nematocyst discharge.
Coelenterate	: An Invertebrate animal possessing an alimentary opening and tentacles with stinging cells and no anus.
Coelenteron	: Single cavity within the body of a coelenterate. It serves as a gut and body cavity.
Diploblastic	: Having only two germ layers, ectoderm and endoderm.
Ectoderm	: Outer layer of cells in the gastrula. This layer gives rise to epidermis, sense organs and nervous system.
Endoderm	: Innermost layer of the early embryo which gives rise to epidermis sense organs and nervous system.
Gastrovascular	: Serving the function of both digestion and circulation.
Gastrula	: Two layered stage in embryonic development of animals.
Hydranth	: Flower-like terminal part of hydroid polyp containing mouth and tentacles; feeding polyp.

- Hydrotheca : The vase-like protective covering which covers the polyps of the colonial hydrozoan Obelia.
- Mesoglea : Often jelly containing layer between ectoderm and endoderm layers of coelenterates and comb jellies.
- Metazoa : Multicellular
- Planula : Ciliated, free-swimming larval form of most coelenterates.
- Polymorphism : Occurance of more than one form performing diverse functions.
- Radial Symmetry : A condition in which similar parts are arranged about a common centre like spokes of a wheel.
- Velum : Membranous band of tissue.

BRAOU

UNIT - 8 : PLATYHELMINTHES GENERAL CHARACTERS AND CLASSIFICATION

Contents

- 8.1 Objectives
- 8.2 Introduction
- 8.3 General Characters
- 8.4 Classification
 - 8.4.1 Class — Turbellaria
 - 8.4.2 Class — Digenea
 - 8.4.3 Class — Aspidogastrea
 - 8.4.4 Class — Monogenea
 - 8.4.5 Class — Cestoda
- 8.5 Summary
- 8.6 Check Your Progress — Model Answers.
- 8.7 Model Examination Questions.

8.1 OBJECTIVES

In this we deal with the general characters and the concept of acoelomate condition. In flatworms, two thirds of which are parasitic in invertebrates and vertebrate. After studying this unit you will explain the concepts that Platyhelminthes are primitive, bilaterally symmetrical animals which have gone ahead in evolution.

8.2. INTRODUCTION

The flatworms comprise five classes of which four are entirely parasitic. They consists of flukes and tape worms. The only one class, the Turbellaria are free living worms. The reproductive system in all is hermaphroditic.

8.3 GENERAL CHARACTERS

1. These are triploblastic bilaterally symmetrical, acoelomate metazoans.
2. These are called flat worms because they are dorsoventrally flattened.
3. These are free-living and parasitic.
4. Some parasites have chitinous hooks and suckers for attachment.
5. The space between the various organs is filled with a special connective tissue called parenchyma.
6. Digestive system consists of mouth, pharynx and intestine without anus. In some it is absent.
7. Respiratory and circulatory systems are absent.
8. Excretory system consists of flame cells and excretory canals.
9. Nervous system is primitive. It consists of a pair of cerebral ganglia or brain and 1 to 3 pairs of longitudinal nerve cords with transverse connections.
10. Sense organs are more abundant in Turbellaria and reduced in parasitic forms.
11. With few exceptions, flat worms are hermaphrodites.
12. The most peculiar feature of the phylum is the presence of male and female reproductive organs.
13. Fertilisation is internal, cross-fertilisation in trematodes and self-fertilisation in cestodes is common.
14. Development may be direct or indirect with one or more larval stages.
15. Life-cycle involves one or more hosts.

8.4 CLASSIFICATION

The phylum Platyhelminthes comprises of five classes. They are:

1. Turbellaria, 2. Digenea, 3. Aspidogastrea, 4. Monogenea and 5. Cestoda.

8.4.1 Class: Turbellaria

1. They are mostly **free-living**, occur in moist soil, fresh water and sea.
2. Size varies 2 mm to 60 mm, few are **microscopic**.
3. Body may be slender, leaf-like, rounded or oval in shape, bilaterally symmetrical and unsegmented without proglottides.
4. Body colour may be brown, grey or black. Land planarians and polyclads are brightly coloured.
5. The anterior end is differentiated into "head".
6. Epidermis is cellular, partly or wholly ciliated and has crystalline rod-like rhabdites.
7. Alimentary canal consists of ventral mouth, protrusible pharynx and intestine which varies considerably.
8. With rare exceptions all Turbellaria are **hermaphrodites**.
9. Development is direct with Juvenile form.
10. Juvenile worm emerges from the egg or cocoon which resembles the adult.
11. Occasionally a free-swimming larva is present.
12. Some Turbellarians are **commensals or parasites**.

e.g. *Planaria*, *Temnocephala* (Fig. 8.1 A & B)

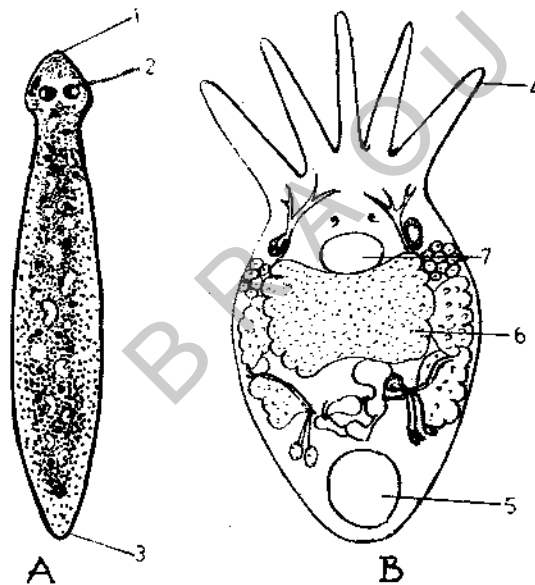

Fig. 8.1 Representatives of Turbellaria. A. *Planaria*. B. *Temnocephala*. 1. Anterior end. 2. Eye. 3. Posterior end. 4. Tentacles. 5. Sucker. 6. Intestine. 7. Pharynx.

8.4.2 Class: Digenea

1. These are **endo-parasites**.
2. Body is flattened and leaf-like
3. These are usually with two suckers, without hooks.
4. The epidermis of adult is devoid of cilia and rhabdites.
5. Gut always present, provided with oral sucker, pharynx and bifurcated intestine.
6. Excretory system consists of a longitudinal canal terminating by a single posterior excretory pore.

7. With few exceptions all are hermaphrodites, genital aperture is common, a vagina is lacking, uterus along with many eggs.
8. Life-history complicated having two or more hosts.

e.g. *Fasciola*, (Fig. 8.2. A) *Schistosoma*, (Fig 8.2. B), *Paragonimus* (Fig. 8.2. C):

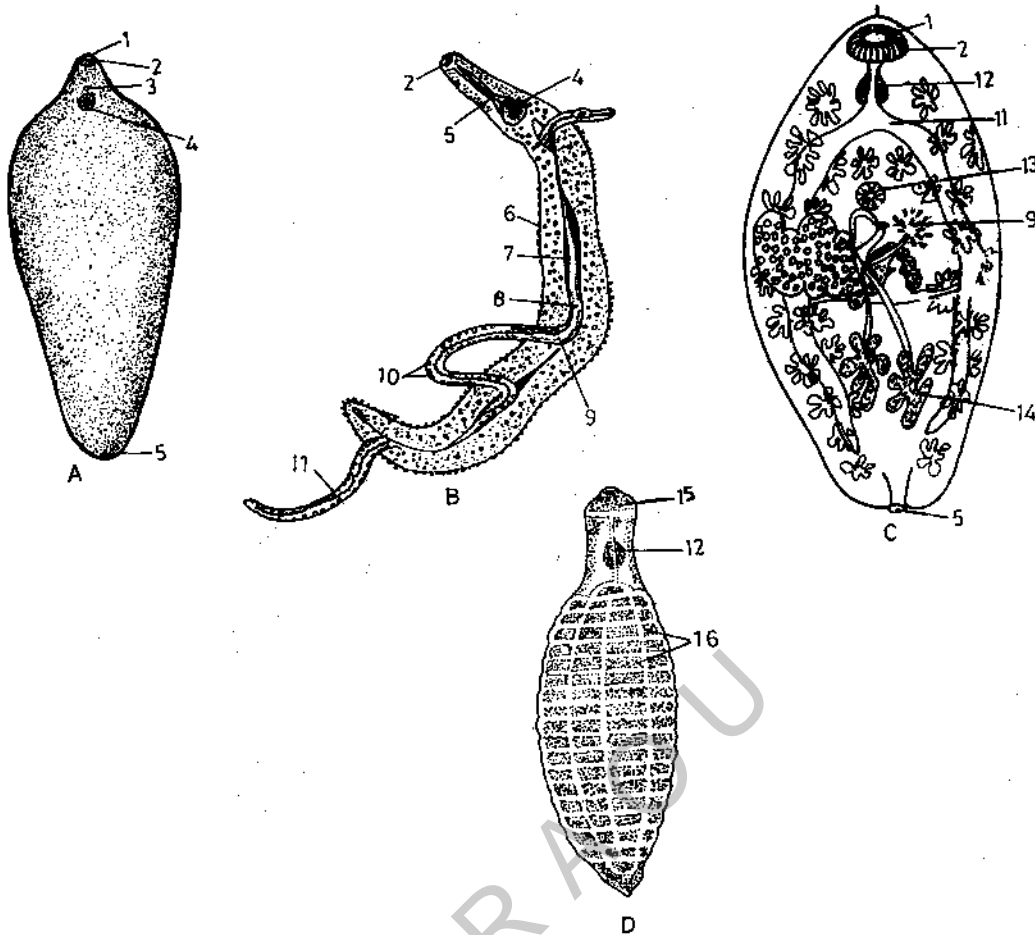

Fig. 8.2. Representatives of Digenia and Aspidogastrea. A. *Fasciola hepatica*. B. *Schistosoma*. C. *Paragonimus*. D. *Aspidogaster*. 1. Mouth. 2. Oral sucker. 3. Gonopore. 4. Acetabulum. 5. Excretory pore. 6. Male. 7. Gynecophoric canal. 8. Female. 9. Ovary. 10. Yolk glands. 11. Intestine. 12. Pharynx. 13. Ventral sucker. 14. Testis. 15. Mouth funnel. 16. Alveoli.

8.4.3 Class: Aspidogastrea

1. These are endo-parasites.
2. Funnel-like mouth without oral sucker, is present.
3. Attachment organ consists of very large ventral sucker. It is sub-divided into one or more longitudinal rows of alveoli or several distinct suckers.
4. The epidermis is devoid of cilia and rhabdites.
5. Gut is always present. It has mouth, pharynx and simple intestine.
6. In adult there is usually a single posterior excretory pore.
7. Direct development in a single invertebrate host or vertebrate host.
8. The life-cycle is varied. Larvae are found encysted in invertebrates and adults in vertebrates.
e.g. *Aspidogaster* (Fig. 8.2. D), *Cotylogaster*.

8.4.4 Class: Monogenea

1. These are typically ectoparasites of the skin and gills of fishes. Some are endoparasites in the coelom and very rarely in the gut of fishes and others in the pharynx and urinary bladder of amphibians and reptiles.

2. Mouth either simple or surrounded by an oral sucker or buccal cavity containing a pair of eversible suckers.
3. Monogenea have an adhesive apparatus at either end of the body. The anterior adhesive apparatus is called **prophaptor**. The posterior adhesive apparatus is known as **opisthaptor**. The posterior sucker may bear anchors in the form of hooks or claws.
4. Epidermis of adult is devoid of cilia and rhabdites.
5. Gut nearly always present (absent in Gyrocotylidea). It is typically with pharynx and bifurcated intestine.
6. Excretory system terminates in a pair of lateral pores at the anterior end.
7. Male and female genital pores usually separate, one or two vaginae present, uterus simple with few eggs.
8. Life-history is simple. They have a single larval form and no intermediate host.

e.g. *Gyrodactylus* (Fig. 8.3 A), *Polystomum* (Fig. 8.3 B).

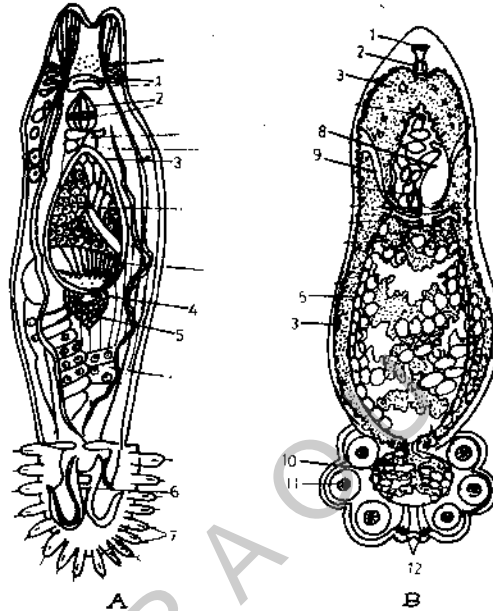

Fig. 8.3. Representatives of Monogenea. A. *Gyrodactylus*. B. *Polystomum*. 1. Mouth. 2. Pharynx. 3. Intestine. 4. Fertilized ovum. 5. Testis. 6. Anchor. 7. Marginal books. 8. Germarium. 9. Vagina. 10. Vitelline ducts. 11. Sucker. 12. Hooks.

8.4.5 Class: Cestoda

1. These are commonly called as tapeworms because of their flat ribbon like form.
2. These are all endo-parasites of vertebrates from fishes to mammals.
3. With few exceptions, the tapeworms consists of scolex, neck and strobila or body. Body is divided into a series of segments called **proglottides**.
4. The attachment organ constituting a '**scolex**' is situated at anterior end of the body.
5. Epidermis is devoid of cilia and rhabdites but provided with microvilli.
6. Mouth and alimentary canal absent. No circulatory and no distinct excretory system.
7. Nervous system consists of a pair of ganglia and two lateral longitudinal nerve cords.
8. There are no sense organs.
9. Usually the cestodes are **hermaphrodites**. A single set of reproductive organs is found in a single proglottid.
10. A proglottid consists of both male and female reproductive organs.
11. Self-fertilisation takes place.
12. The egg gives rise to a characteristic **onchosphere** (six hooked) stage.
13. The life-cycle varies in different forms involving one or more than one intermediate host.

e.g. *Taenia*. (Fig. 8.4. A.) *Diphyllobothrium* & *Echinococcus* (Fig. 8.4. B.).

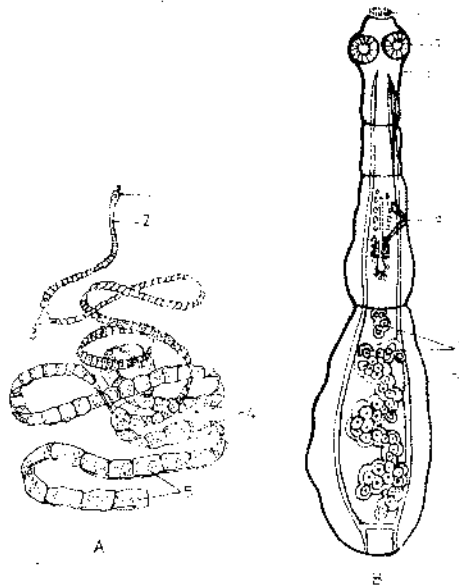

Fig. 8.4 A. *Taenia* B. *Echinococcus* 1. Scolex 2. Neck 3. Strobila 4. Immature Proglottids 5. Gravid Proglottids 6. Hooks 7. Sucker 8. Genital opening 9. Branched uterus 10. Gravid Segment.

Check your progress

1. Dorsoventrally flattened, acoelomate bilaterally symmetrical animals are included in phylum
2. Flukes are thin, flat and whereas tapeworms are thin, long, segmented and

8.5 SUMMARY

Platyhelminthes are flat worms. They include planarians, flatworms, tape worms and flukes. They are bilaterally symmetrical, acoelomate metazoans. They have well developed organ systems.

8.6 CHECK YOUR PROGRESS — MODEL ANSWERS.

1. Platyhelminthes.
2. leaf like, ribbon like

8.7 MODEL EXAMINATION QUESTIONS

- I. Answer the following in about 30 lines.
 1. Describe the general characters of phylum platyhelminthes.
 2. Mention the characteristic features of class cestoda. Give examples.
- II. Answer the following in about 10 lines.
 1. Mention important characteristic features of class Turbellaria.
 2. Mention important characteristic features of class Digenea.

UNIT — 9 IMPORTANT TREMATODES AND CESTODE PARASITES

Contents

- 9.1 Objectives
- 9.2 Introduction to Trematode Parasites
- 9.3 *Fasciola hepatica*
 - 9.3.1 Life-Cycle
 - 9.3.2 Pathogenecity
 - 9.3.3 Control
- 9.4 *Schistosoma hematobium*
 - 9.4.1 Life-cycle
 - 9.4.2 Pathology
 - 9.4.3 Control
- 9.5 Introduction to Cestode Parasites
- 9.6 *Taenia solium*
 - 9.6.1 Pathogenicity
 - 9.6.2 Control.
- 9.7 *Echinococcus granulosus*
 - 9.7.1 Life-cycle
 - 9.7.2 Pathogenicity
 - 9.7.3 Control.
- 9.8 Summary
- 9.9 Check Your Progress -- Model Answers
- 9.10 Model Examination Questions.
- 9.11 Glossary.

9.1 OBJECTIVES

This unit deals with the important parasites of man and domestic animals and the diseases caused by them. At the end of this unit you will be able to explain the parasitic adaptations, which modify both internal and external structures and have the survival value.

9.2 INTRODUCTION TO TREMATODE PARASITES

1. The thin cuticle of Digenea is often spiny. Beneath the cuticle, layers of circular, longitudinal and diagonal muscles are present.
2. The internal organs are enclosed in a loose tissue called **Parenchyma**.
3. The digestive system usually has a muscular **pharynx** and intestine with two **intestinal caeca**. In some of the large flukes (e.g., *Fasciola hepatica*) the caeca have numerous branches and sub-branches. In Schistosomes the caeca reunites posteriorly to form a single stem. Only in a few species the caeca open posteriorly.
4. Nervous system is poorly developed. It consists of a small ganglion and few longitudinal nerves.
5. Excretory system consists of branching tubules which end in **flame cells**. The main collecting tubules open into a posteriorly situated bladder. In digenetic flukes the type of excretory system is of great value in classification.
6. In all flukes except those of the family Schistosomatidae both male and female reproductive organs occur in the same individual.
7. Male reproductive system consists of two testes, two vasa efferentia and one vas deferens, a seminal vesicle, and ejaculatory duct The terminal part of the vas deferens is modified, into a

muscular cirrus. The seminal vesicle leads into an ejaculatory duct before opening into genital atrium. The cirrus serves as the organ of copulation.

8. Female reproductive system consists of a single ovary, oviduct, two vitellaria and their ducts, a vestigial vagina (Laurer's canal), seminal receptacle, uterus, ootype and Mehlis gland. The uterus arises from the ootype. It terminates in the genital atrium. The genital duct opens on the ventral surface near the acetabulum.
9. Life-cycle of Digenea passes in two different hosts.
 1. **Definitive host** is generally man. The adult worm lives in this host.
 2. **Intermediate host** is a fresh water snail or mollusc where larval development takes place.

Sometimes a second intermediate host (fish or crab) is required for encystment.

The eggs liberated by the definitive host enter the water. A free - swimming ciliated larva, miracidium develops and hatches out of the egg. The miracidium develops further if it comes across the proper intermediate host (snail or mollusc)

9.3 FASCIOLA HEPATICA

Phylum	-	Platyhelminthes
Class	-	Trematoda
Order	-	Digenia
Genus	-	<i>Fasciola</i>
Species	-	<i>F. hepatica</i>

Fasciola hepatica is a parasite in the bile ducts and liver of sheep (in goat and cattle also).

9.3.1 Life-Cycle

Fasciola passes its life-cycle in two different hosts.

Definitive host: sheep, goat, cattle or man.

Intermediate host: snails of the genus *Limnaea*

The eggs are passed out along with the faeces of the definitive host. These become, mature in water. The eggs are oval, light brown in colour, measure 140 microns. Inside each egg a ciliated miracidium is developed in about 2 to 3 Week's time. The egg shell opens at one end by a lid or operculum. Through the lid, the miracidium larva which is some what conical in shape comes out. It is covered all over by cilia and has two eye spots near the anterior end. The anterior end is provided with triangular head lobe. A pair of **flame cells** is present. The rest of the interior is filled with a mass of germ cells. The ciliated larva swims about in water or moves over to damp herbage for some time. If it does not reach the water snail belonging to the genus *Limnaea* it perishes. The miracidium after entering into the snail it loses the ciliated epidermis and rests in the mantle cavity of the snail. It grows rapidly into an elongated sac, the **sporocyst** with an internal cavity containing germ cells. The eye spots and flame cells are degenerated. Finally the germ cells undergo a process of cleavage and give rise to **redia**. This redia begins to move about and finally comes out of the sporocyst. Then it reaches the digestive gland of the snail. When fully formed the redia has a cylindrical body, a pair of short processes at the posterior end and a circular ridge (collar) near the anterior end. It possesses a mouth leading into the pharynx and a simple sac - like intestine. There is a system of excretory vessels. Inside the redia are undifferentiated germ cells. These **germ cells** develop into a fresh generation of redia in winter or to **cercariae** in summer. The cercariae are provided with long tails, anterior and posterior suckers, a mouth, pharynx and bifid intestine. In the wall of the redia the birth pore is formed near the collar. Through this pore the cercariae escape. They move actively by means of their tails and force their way out of the body of the snail. The mature cercariae after escaping from the snail becomes encysted and are called **metacercariae**. These metacercariae are attached to the blades of grass or leaves of other herbage. If the sheep swallows the grass on which the metacercariae are encysted they get infected. The

young fluke then escapes from the cyst and reaches the liver passing over the viscera. Finally it enters the bile ducts and reaches the sexual maturity. (Fig. 9.1)

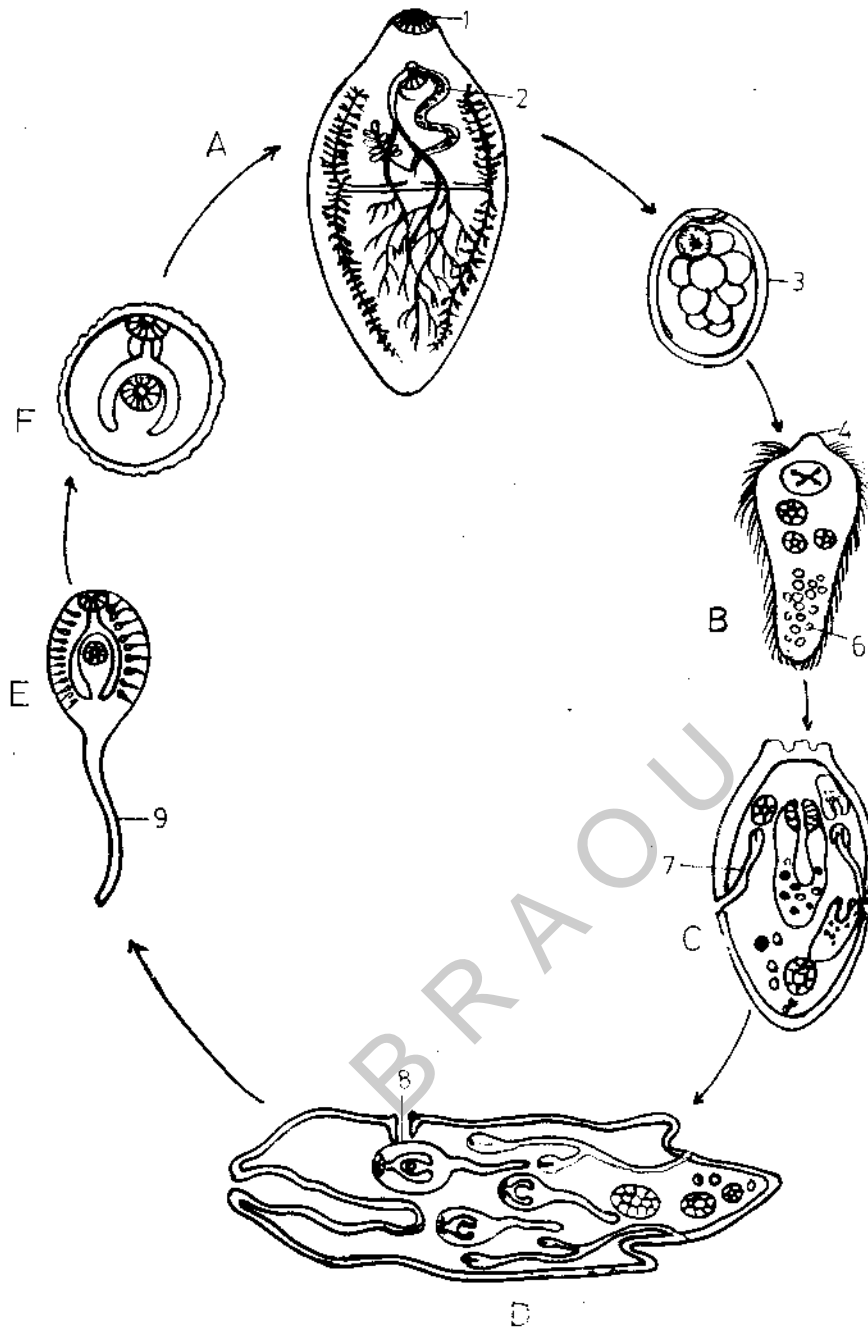
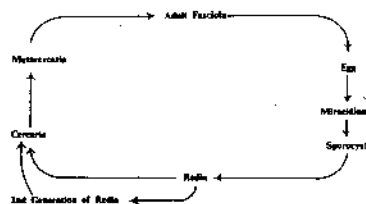

Fig.9.1 Life cycle of *Fasciola hepatica*. A. Adult Fasciola. B. Miracidium. C. Sporocyst. D. Redia. E. Cercaria. F. Metacercaria. 1. Oral sucker. 2. Ventral sucker. 3. Operculated egg. 4. Head lobe. 5. Cilia. 6. Germ cells. 7. Flame cells. 8. Birth pore. 9 Tail

LIFE - CYCLE OF FASCIOLA



9.3.2 Pathogenicity

1. *Fasciola hepatica* is primarily responsible for producing a disease in animals known as liver-rot.
2. During migration of the young worms in the biliary passages they cause extensive damage to the liver tissue.
3. In the biliary passages, they interfere with the normal flow of bile, causing obstructive jaundice.
4. They produce cystic dilatation of bile ducts. The wall of bile ducts become greatly thickened by the development of fibrous tissue.

9.3.3 Control

1. Destruction of snails is the most suitable measure to control the parasite.
2. Draining of pastures helps to exterminate the snails. If this is not possible it is useful to introduce ducks and geese which eat up the snails.
3. The adult worms in the host can be killed with antihelminthic drugs, such as carbon tetrachloride, Emetine and Tetrachloroethane etc.

9.4 SCHISTOSOMA HEMATOBIMUM

Phylum	-	Platyhelminthes
Class	-	Trematoda
Order	-	Digenia
Genus	-	<i>Schistosoma</i>
Species	-	<i>S. hematobium</i>

Common name: Visceral blood fluke

Schistosoma hematobium is a parasite in the blood vessels of man. It is **dioecious**. The two sexes remain close together in pairs. The male is thicker and smaller than female. The ventral side of male body is deeply infolded to form the **gynaecophoral canal**, in which the female lies.

9.4.1 Life-cycle

Schistosoma hematobium passes its life-cycle in two hosts

Definitive host: Man

Intermediate host: Fresh water snail (*Bulinus truncatus*)

Embryonated eggs are passed out with the urine of the definite host and enter water. The ciliated larvae (**miracidia**) hatched out of the eggs move freely in water in search of intermediate host. The miracidium on entering the proper intermediate host, (snail) penetrates into the soft tissues of snail and finally makes its way into the liver. Here it loses its cilia and other organs and in 4 to 8 weeks undergoes developmental changes. The miracidium is transformed into a tubular *sporocyst*. The sporocyst multiplies and forms a second generation of sporocysts. Several weeks after the infection, when no further multiplication occurs, the daughter sporocysts give rise to the final larvae forms, the fork-tailed **cercariae**. These are infective to man. The cercariae break off from the sporocyst and escape from the snail into water. Infection occurs when human beings bathe or wade in water in which the cercariae are present. The cercariae penetrate the skin of a person where they cast off their tails, enter the blood capillaries and then reach the liver. Cercariae larvae reach the portal system of the host through lymph vessels, venous blood vessels, mesenteries and capillaries. They feed on blood and develop into adults. When the worms are sexually mature, they copulate and the females lay eggs. These eggs finally come out along with the urine (Fig. 9.3)

Dr. BRAOU
LIBRARY

Acc. No. 21496
Class No. 591
200

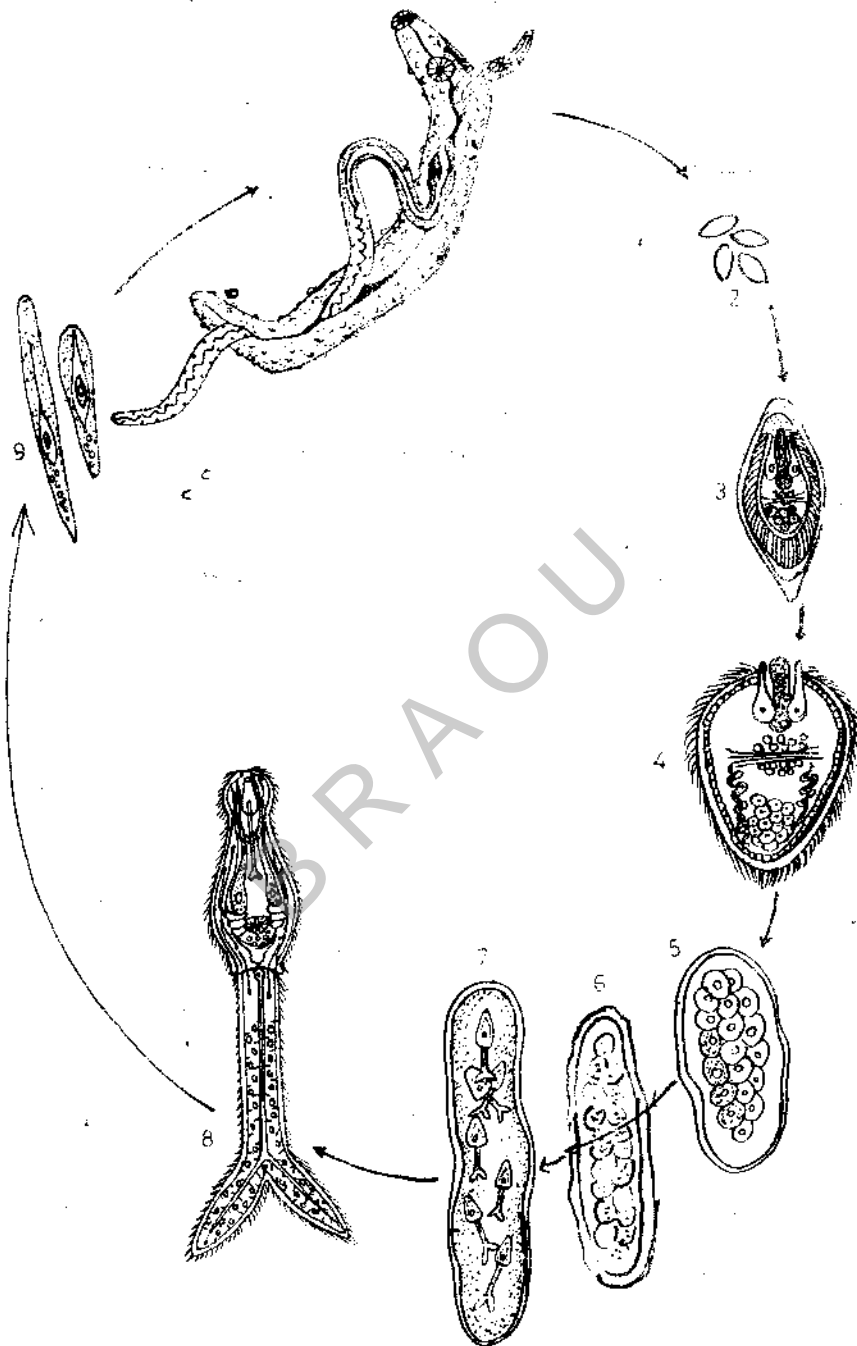
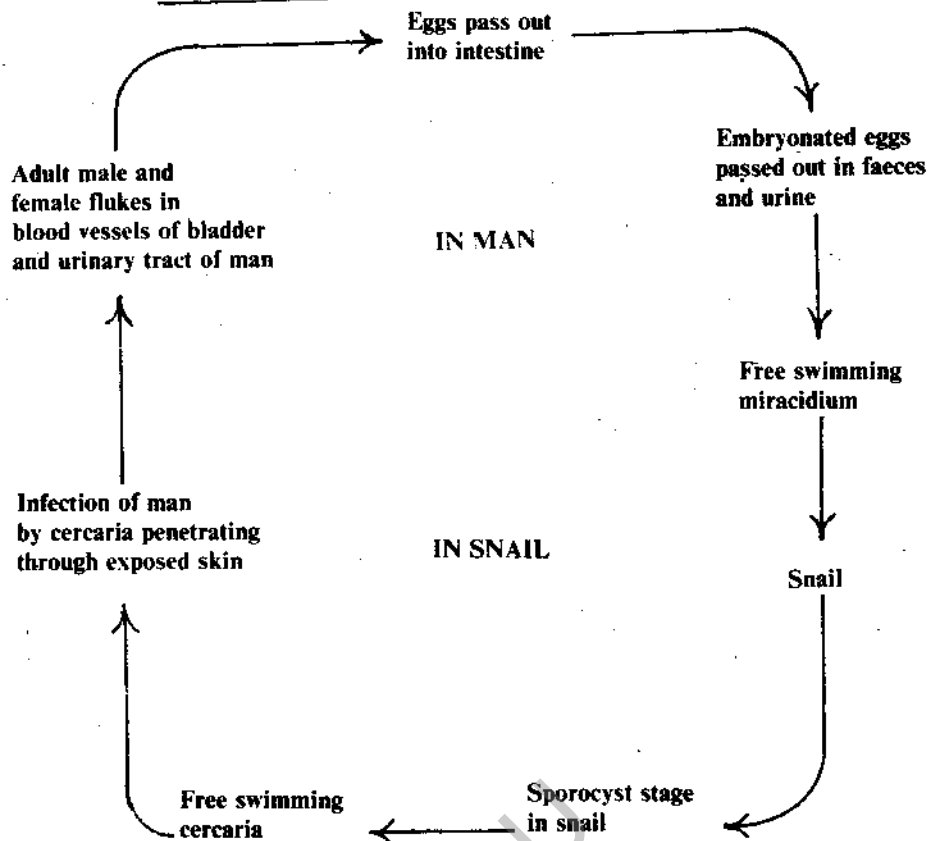

Fig. 9.3. Life cycle of *Schistosoma*. 1. Mature adult worms. 2. Eggs. 3. Egg containing a ciliated embryo. 4. Miracidium. 5. Sporocyst (1st Germination). 6. Sporocyst (2nd Generation). 7. Development phases in snail. 8. Cercaria. 9. Schistosomes developing into adult worms.

LIFE - CYCLE OF SCHISTOSOMA (GRAPHIC)



9.4.2 Pathology

1. The disease is known as **schistosomiasis**.
2. Itching in the skin is caused by the penetrating cercariae.
3. The cercariae of a number of blood flukes of aquatic birds can also penetrate human skin causing **dermatitis** or skin inflammation i.e. swimmer's itch.
4. During migration from skin to portal system they cause **head-ache**, **eosinophilia**, **diarrhoea** and **dysentery**.
5. During egg - laying, it causes pain in the urinary bladder. A kidney trouble with discharge of blood called **hematuria** may be caused.
6. Eggs may also be deposited in the arterioles of lungs causing **cardio-pulmonary schistosomiasis**.

9.4.3 Control

1. Schistosomiasis can be cured by use of antimony compounds, such as Tartar emetic, Fudin etc.,
2. Snails serving as intermediate hosts can be killed by draining their pastures, by introducing ducks to feed on them.
3. By sprinkling copper sulphate or copper carbonate on contaminated waters, schistosomiasis can be controlled.
4. Human infection can be checked by sanitary control of infected water.

9.5 INTRODUCTION TO CESTODE PARASITES

1. Head is provided with **suckers** and sometimes with **hooks** which serve as organs of attachment.
2. The internal organs are embedded in spongy **parenchyma**.

3. The nervous system consists of a few ganglia and longitudinal nerve cords.
4. The excretory system consists of lateral longitudinal tubes which are connected by a transverse tube near the posterior end of each proglottid and finally opens to the outside in the last proglottid. From the ventral vessels arise fine capillaries that end in **flame cells**.
5. The male reproductive system consists of a variable number of scattered testes, vasdeferens and seminal receptacle for the storage of sperms. The terminal part of the vas deference is muscular and is known as cirrus. In most tapeworms both cirrus and vagina open into a common genital atrium with a pore on either the lateral border or the mid ventral surface.
6. Female reproductive system consists of an ovary which may be single or in two, more or less distinct lobes. Mehlis glands are around ootype, where the component parts of the egg are assembled. A vagina for the entrance of sperms with an enlarged chamber, the seminal receptacle for storage of sperms and a uterus which may or may not open outside are present.
7. In the tape worms which have uterine pore (Pseudo phyllidea) the development and extrusion of eggs goes on continuously in many segments at once. In Cyclophyllidea where there is no uterine opening, the uterus becomes completely filled with eggs. Such "ripe" segments detach themselves from the end of the chain liberating the eggs.
8. Either self-fertilisation of a single segment or cross fertilization between different segments of the same or other worms can occur. But probably fertilization between segments of the same worm is common. The life-cycle is not so complicated as in flukes.
9. The eggs of tape worms develop within themselves little spherical embryos characterised by the presence of three pairs of hooks, hence they are known as **onchospheres**. On being eaten by a final host only the scoleces survive and attach themselves to the mucous membrane of the intestine and grow, each into adult worm.

9.6 TAENIA SOLIUM

Phylum	-	Platyhelminthes
Class	-	Cestoda
Order	-	Cyclophyllidea
Genus	-	<i>Taenia</i>
Species	-	<i>T. soleum</i>

Common name: The pork tape worm, the armed tape worm of man

The adult worms of *Taenia solium* live in the small intestine of man. The eggs develop within themselves little spherical embryos. These embryos possess three pairs of hooks. They are known as **onchospheres**. One or two enclosing membranes inside the egg shell proper form the developing embryo, the inner membrane is called embryophore. The eggs are passed with the human faeces. After reaching the alimentary canal of the intermediate host (pig) the straited walls of the eggs rupture and onchospheres are liberated. These penetrate the gut wall with the hooks and reach blood or lymph vessels. Soon they leave the blood and enter the straited muscles, particularly in the tongue, neck, heart and limbs. In the muscles, hexacanth loose hooks, grow in size and develop a fluid-filled cavity in them. They now encyst in a cuticular covering and the encysted larvae are called **bladder worms** or **cysticerci**. They are oval, whitish bodies about 10 mm x 6 mm. The fluid within them is largely composed of host's blood plasma. The side of the bladder opposite to that originally occupied by the hooks thickens and invaginates into the cavity as a hollow knob. **Rostellum**, hooks and suckers appear at the bottom of the invagination. Thus an inverted scolex called **proscœlex** is formed. The cysticercus with proscœlex is infective and waits for its ingestion by man. The onchospheres take about four months to develop into infective cysticercus. The infected pork has brownish spots and is called the "measly pork". Human infection occurs by taking raw or undercooked measly pork. In the human intestine, the cysticercus casts off its bladder and evaginates its proscœlex so that the suckers, hooks and rostellum come to lie on the outer surface as in the adult worm. Thus a young worm with a scolex and a small neck is formed. In about 2-3 months, the worm becomes adult (Fig. 9.4).

9.6.1 Pathogenicity

1. These parasites may cause abdominal discomforts such as excessive appetite, pains chronic indigestion, weight loss, diarrhoea and nervous discomforts.
2. Sometimes man may accidentally ingest eggs or proglottides which enter the stomach and liberate the oncospheres there. During such auto-infection and regular infections, the cysticercus larvae in the tissues cause cellular changes such as infiltration of polymorpho-nuclear leucocytes.
3. Infection by cysticercoid is often more serious than infection by adult worm. Cysticercosis in the nervous system causes severe disorders such as necrosis of brain and epilepsy. This control disease is often fatal.

9.6.2 Control

1. The oncospheres may be destroyed through proper disposal of human faeces by sewage system or by preventing the pigs from visiting human faeces.
2. The cysticerci can be killed by thoroughly cooking the pork or by its quick freezing.
3. Yomesan, 1 gm of Hexylresorcinol with 2 gm of Acaecia may be given to remove the adult worms. These usually remove the strobila only. Scolices can be removed only with a surgical method.

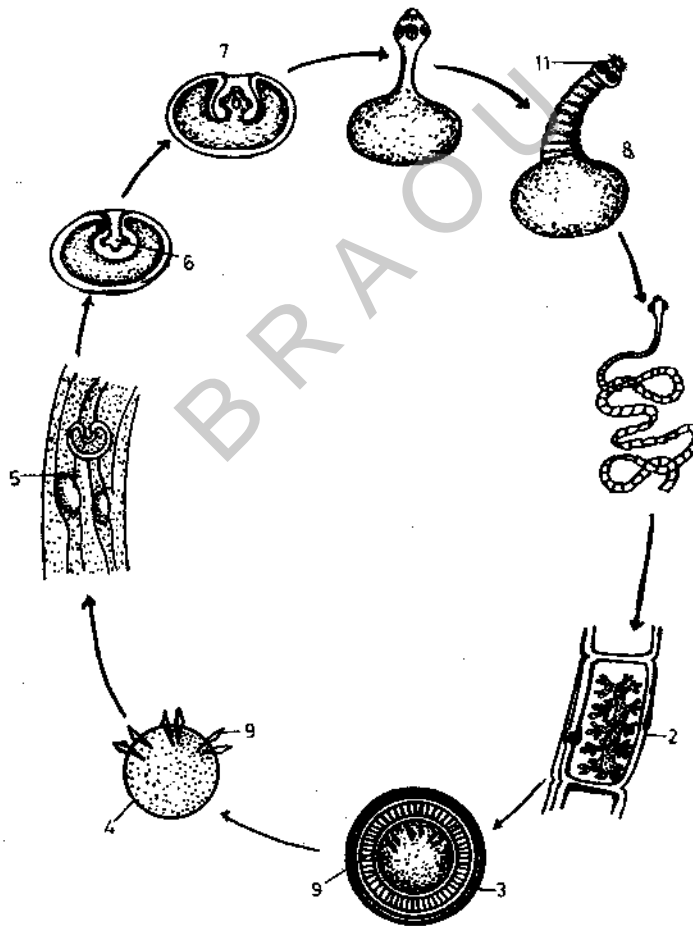
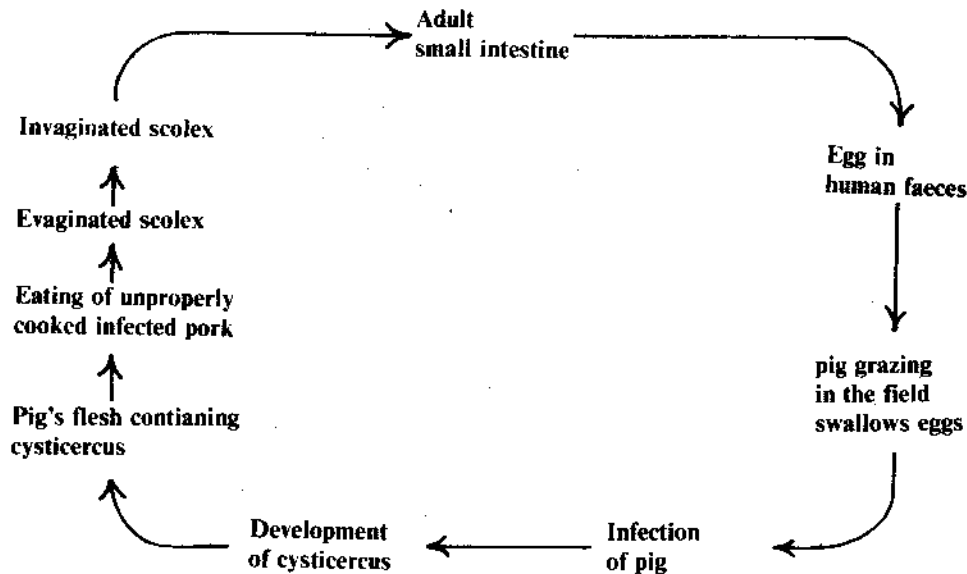

Fig. 9.4. Life cycle of *Taenia solium* 1. Adult *Taenia*. 2. Gravid segment. 3. Egg in human faeces. 4. Hexacanth. 5. Pig muscles containing cysticercus. 6. Inverted scolex. 7. Everted scolex. 8. Young tapworm. 9. Hooks. 10. Rostellar hooks. 11. Scolex.

LIFE CYCLE OF TAENIA SOLIUM (GRAPHIC)



9.7 ECHINOCOCCUS GRANULOSUS

Phylum	-	Platyhelminthes
Class	-	Cestoda
Order	-	Cyclophyllidae
Genus	-	<i>Echinococcus</i>
Species	-	<i>E. granulosus</i>

Common name: Dog tape worm, the hydrated adult worms are found in the canine animals.

9.7.1 Life-Cycle

The life-cycle takes place in two hosts.

1. **Definitive host:** Dog, wolf, fox and jackal.
2. **Intermediate host:** Sheep, pig, cattle, goat and man.

The eggs are discharged with the faeces of the definite host (dog etc). These are swallowed by the intermediate host, sheep and other domestic animals while grazing in the field and also by man (particularly children due to the intimate handling of infected dogs). In the duodenum the embryonic shell is dissolved by the digestive juices and the typical six hooked embryo hatches. About 8 hours after ingestion the embryos bore their way through the intestinal wall and enter the portal vein. The embryos are carried to the liver. Some of the embryos may pass through the hepatic capillaries, enter the pulmonary circulation and filter out in the lungs. A few of the embryos may pass through the hepatic capillaries, enter the pulmonary circulation and filter out in the lungs. A few of the embryos may pass the pulmonary capillaries, enter the general blood stream and lodge in the various organs. Practically all the organs of the domestic animals may be invaded but they are chiefly found in the liver and lungs. Wherever the embryo settles, it forms a **hydatid cyst**. The young larvae get transformed into a hollow bladder. From the inner side of the cyst, brood capsules with a number of scolices are developed. A hydatid cyst developing from the single egg (onchosphere) may contain thousands of scolices. These multiple scolices present a spiny and berry like appearance. Hence the generic name *Echinococcus* (Echinus: spiny; coccus: berry). A fully developed scolex inside the hydatid cyst is the sign of complete development. These fertile hydatids when ingested by the dog grow into adult worms in about 6 to 7 week's time in the intestine. Thus the cycle is repeated. Life span of adult worm in the canine host is short (about 6

months). life span of larval worm is long and may continue to develop for many years (Fig. 9.5).

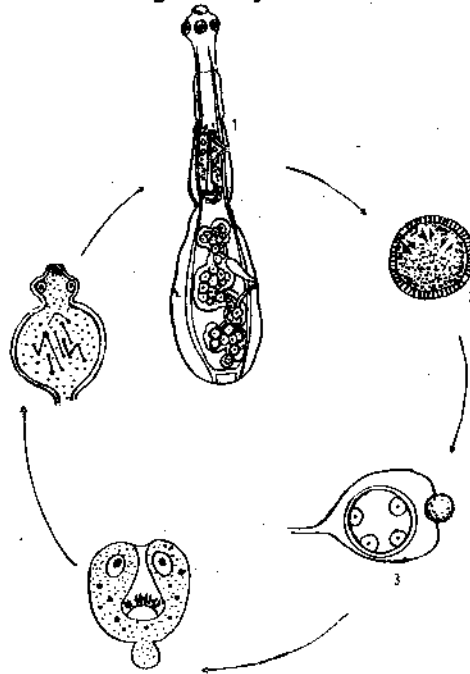

Fig. 9.5 Life cycle of *Echinococcus granulosus*. 1. Adult *Echinococcus*. 2. Egg. 3. Hydatid cyst larval stage.

9.7.2 Pathogenicity

1. Cysts are harmful when they develop rapidly. Inflammatory reactions in the surrounding tissues of the host result in the development of fibrous tissue.
2. The osseous tissue is weakened. The liver is enlarged,
3. The presence of cysts in brain or eyes is harmful.
4. The escaping hydatid fluid contains toxins and causes vomiting, diarrhoea, abdominal pain, eosinophilia and sometimes collapse.

9.7.3 Control

1. Avoid playing with dogs.
2. Hands should be thoroughly washed before eating.
3. Dogs should not be allowed to eat raw meat and viscera of sheep, cattle and dogs.

Check Your Progress

1. Endo and exoparasites develop many structures like suckers, rostellum with hooks have complicated life cycles with many larval stages and loss of organs - all these are combinedly called as
2. Most of the platyhelminths live as endoparasites in vertebrate hosts but peculiarly their intermediate hosts are

9.8 SUMMARY

These are dorso - ventrally flattened, bilaterally symmetrical acoelomate worm like animals, without definite anus, circulatory, skeletal and respiratory systems. The space between the various organs is filled by tissue called parenchyma excretory system consists of protonephridia. Usually hermaphrodites with complex reproductive organs. This unit deals with the worms belonging to two classes. 1. Digenea 2. Cestoda.

9.10 CHECK YOUR PROGRESS — MODEL ANSWERS

1. parasitic adaptations
2. invertebrates

9.11 MODEL EXAMINATION QUESTIONS

I. Answer the following in about 30 lines

1. Give an account of life-cycle of *Fasciola hepatica*.
2. Describe the life-history of *Schistosoma hematobium*. Add a note on its pathogenicity.
3. Give an account of life-cycle of *Taenia solium*. Add a note on its pathogenicity.

II. Answer the following in about 10 lines

1. Briefly describe the life cycle of *Echinococcus granulosus*.
-

9.12 GLOSSARY

Acoelomate	: An animal without coelom (body cavity).
Cercaria	: A larval stage in the life-cycle of flukes produced by a redia and infects the final host where it encysts.
Cleavage	: The early divisions of the fertilized egg.
Ganglion	: An aggregated collection of cell bodies of neurons typically less complex than a brain
Hermaphrodite	: An organism possessing both male and female reproductive structures.
Host	: An organism which provides shelter food and other benefits to another organism.
Hydatid cyst	: A large cyst formed by a tapeworm of the genus <i>Echinococcus</i>
Invaginate	: Folding or infusing of a layer of cells into a cavity of a blastula to form a gastrula.
Miracidium	: A larval stage in the life-cycle of flukes develops from an egg.
Onchosphere	: A larval form of some tape worms.
Operculum	: A lid-like structure
Ovary	: The egg producing organ of animals.
Parasite	: An organism living at the cost of another organism.
Parenchyma	: A soft connecting tissue filling spaces between organs in some worms.
Planarians	: Any member of the class of free-living flat-worms.
Redia	: A larval stage in the life-cycle of flukes produced by sporocysts.
Sporocyst	: A larval stage in the life-cycle of flukes.
Schistosomiasis	: Disease caused by blood flukes.

UNIT - 10 ASCHELMINTHES - GENERAL CHARACTERS AND CLASSIFICATION

Contents

- 10.1 Objectives
- 10.2 Introduction
- 10.3 General Characters
- 10.4 Classification
 - 10.4.1 Class - Nematoda
 - 10.4.2 Class - Nematomorpha
 - 10.4.3 Class - Rotifera
 - 10.4.4 Class - Gastrotricha
 - 10.4.5 Class - Kinorhyncha
- 10.5 Summary
- 10.6 Check Your Progress — Model Answers
- 10.7 Model Examination Questions

10.1 OBJECTIVE

This deals with the general characters of Aschelminthes and the diversity existing in different classes of this phylum. This also deals with the concept of pseudocoelomate condition. On concluding this unit you will be in a position to explain that this group typically has a fluid filled body cavity between the body wall and the internal organs, mesodermal parts located outside the cavity and which represent the embryonic blastocoel.

10.2 INTRODUCTION

All pseudocoelomates are grouped within a single phylum, the Aschelminthes. The classes are highly diversified. Hence each one is considered to represent a separate phylum. But the binding common factor among these groups is their fundamental body plan possessing a pseudocoelom.

10.3 GENERAL CHARACTERS

1. These are cylindrical bilaterally symmetrical, triploblastic pseudocoelomate metazoans.
2. Mostly aquatic, fresh water or marine, while some are terrestrial, free living as well as parasitic.
3. Some are microscopic and some are long, a meter or more in length. Body usually vermiform, unsegmented or superficially segmented.
4. Anterior end lacks a distinct head.
5. Body covered with thick flexible cuticle. Cuticle often bears spines, bristles.
6. Epidermis is syncytial or cellular.
7. Musculature consists usually longitudinal fibres.
8. Digestive tract is a straight tube from mouth to anus without definite musculature except the pharynx which is well developed and muscular.
9. Respiratory and circulatory systems absent.
10. Excretory system consists of canals and protonephridia.
11. Sense organs consists of ciliated pits, papillae, bristles and eye spots.
12. Mostly dioecious i.e., sexes are separate. Males usually smaller than females. Gonads single or double. Eggs microscopic with chitinous shell.
13. Development direct or indirect with a complete life-history.

10.4 CLASSIFICATION

The phylum Aschelminthes comprises of five classes:-

1) Nematoda 2) Nematomorpha 3) Rotifera 4) Gastrotricha and 5) Kinophyncha.

10.4.1 Class-Nematoda

1. These occur in moist soil, fresh water, sea water, plants and animals.
2. These have an elongated cylindrical vermiform body.
3. They are popularly known as round worms. Head, cilia and segmentation are lacking.
4. Body wall comprises tough resistant cuticle.
5. Epidermis syncytial with four or more longitudinal chords and longitudinal muscles.
6. The digestive tract is complete and straight with mouth and anus. The mouth is provided with 3-6 lips. The pharynx is muscular and has a triradiate lumen.
7. Respiratory and circulatory systems absent.
8. Nervous system comprises a circum-pharyngeal ring with attached ganglia and six anterior and six posterior nerves.

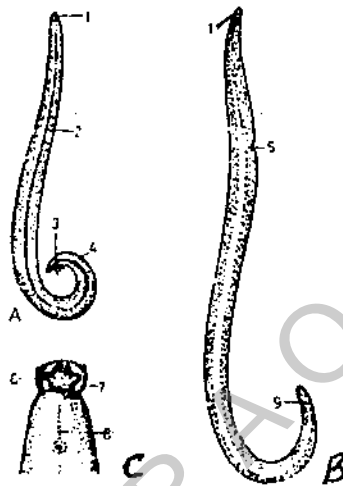

Fig. 10.1. *Ascaris lumbricoides*. A. Male. B. Female. C. Anterior end in dorsal view. 1. Mouth 2. Lateral line 3. Cloacal aperture 4. Penial spicules 5. Female gonopore 6. Papillae 7. Dorsal lip 8. Dorsal line 9. Anus.

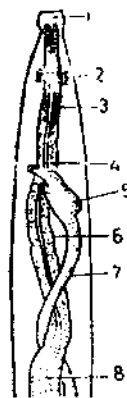

Fig. 10.2 *Wuchereria bancrofti* - Anterior part of female 1. Mouth 2. Nerve ring 3. Pharynx. 4. Vulva 5. Ovijector 6. Pharynx 7. Vagina 8. Intestine.

9. Excretory system simple, consisting of one or two canals or none.
10. Sexes are mostly separate. But hermaphroditic and parthenogenetic forms are also known.
11. Males are smaller than females.
12. Gonads are thread-like and may be single or paired. Spicules are present in males. The male duct opens into the cloaca. The female duct leads to the exterior independently.
13. Fertilization is internal. Development is indirect with or without intermediate host. Larva with several moults.

Eg.: *Ascaris* (Fig. 10.1) *Wuchereria* (Fig. 10.2) *Dracunculus*, *Loa loa* (Fig. 10.3) and *Ancylostoma duodenale* (Fig. 10.4)

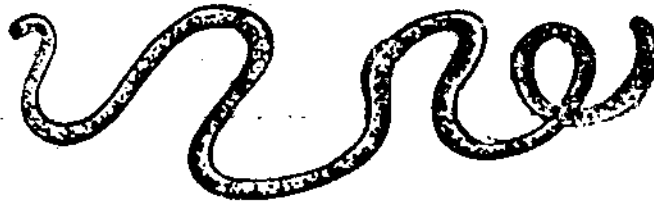

Fig. 10.3 *Loa loa*.

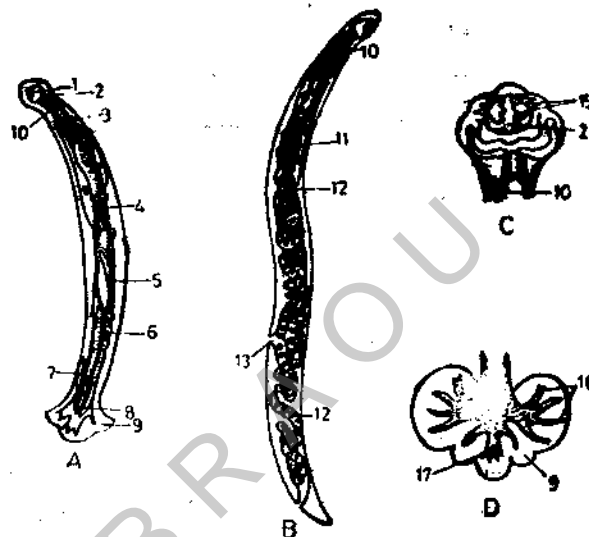

Fig. 10.4. *Ancylostoma duodenale*. A. Adult male. B. Adult female. C. Anterior end. D. Posterior end of male. 1. Mouth 2. Buccal cavity 3. Nerve ring 4. Testis 5. Vesicular seminalls 6. Ejaculatory duct 7. Copulatory spicules 8. Cloaca 9. Copulatory bursa 10. Pharynx 11. Ovary 12. Uterus 13. Vagina 14. Anus 15. Teeth 16. Rays 17. Dorsal rays.

10.4.2 Class Nematomorpha

1. This small class superficially resembles the Nematoda.
2. With the exception of *Nectonema* which is marine, almost all others are found in fresh water.
3. These differ significantly from other classes in the presence of cloaca in both sexes and also differ from Nematoda in the absence of excretory system.
4. These are filiform pseudocoelomates. Body long, slender, cylindrical and unsegmented.
5. Digestive tract degenerate.
6. Circulatory, respiratory and excretory organs are absent.
7. Nervous system consists of circumpharyngeal nerve ring and a single midventral nerve cord.
8. Sexes separate with paired gonads and gonoducts.
9. Juveniles (young ones) are parasitic in arthropods.

Eg. *Gordius*, *Nectonema*

10.4.3 Rotifera

1. These are found in fresh water ponds lakes and some are found in the sea.
2. Body is bilaterally symmetrical and unsegmented.

3. They are known as "wheel animalcules" because the anterior end of the body bears a ciliary apparatus, the "corona" or "trochal disc". The trochal disc is used for feeding and locomotion.
4. The alimentary canal is usually entire with a differentiated muscular pharynx. The pharynx is provided with movable jaws.
5. The nervous system is simple, eye spots usually present.
6. Excretory system has flame cells.
7. Sexes are separate. Males are small and degenerate or absent.
8. Reproduction sexual as well as parthenogenetic. No larval stage.

Eg. *Brachionus* (Fig. 10.5), *Rotifer*.

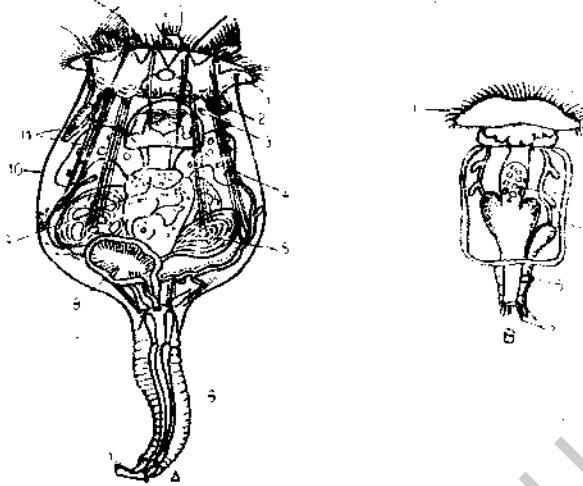

Fig. 10.5. *Brachionus rubens*. A. Female. B. Male. 1. Trochal disc 2. Brain 3. Nephridial tube 4. Pharynx 5. Germarium 6. Tail 7. Toes 8. Intestine 9. Stomach 10. Lorica 11. Muscular bands 12. Testis 13. Flame cell.

10.4.4 Class-Gastrotricha

1. These are small group of free-living microscopic animals.
2. Marine or fresh water.
3. Body worm-like and unsegmented, ventral surface flat with cilia.
4. Cuticle thin, usually spiny, scaly or warty.
5. Corona absent. Posterior end forked and with forked tubes and glands.
6. Digestive tract complete, mouth surrounded with bristles.
7. Nervous system comprises of a cerebral ganglion and two main lateral longitudinal nerves.
8. Sexes are united or only females are present.
9. Reproduction sexual as well as parthenogenetic.
10. Development direct.

Eg. *Chaetonotus* (Fig. 10.6 A), *Lepidodermella*.

10.4.5 Class - Kinorhyncha

1. These are minute cylindrical animals living on mud bottoms usually in shallow marine habitats.
2. Body is cylindrical and is superficially segmented into 13 joints.
3. Cuticle spiny but without cilia.
4. A retractable head covered with circlets of spines.
5. Digestive tract complete, stomach-intestine expanded, anus terminal with retractile ring.
6. Nervous system consists of a dorsal cerebral ganglion and a ganglionated

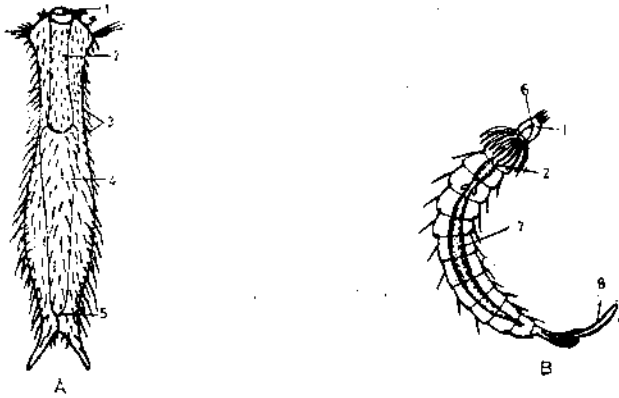

Fig. 10.6. A. *Chaetonotus*. B. *Echinoderes*. 1. Mouth 2. Pharynx 3. Cilia 4. Intestine 5. Anus 6. Mouth cone 7. Stomach-intestine 8. Lateral end spine.

7. Excretory system consists of one pair of short proto-nephridial tubes, starting with a single multinucleate flame bulb.
8. Sexes separate, gonads are tubular sacs. Penial spicules are present in males.
9. Development indirect including several stages and metamorphosis.
Eg: *Echinoderes* (Fig. 10.6 B), *Centroderes*.

Check your progress

The presence of _____ justifies the inclusion of all the five classes of animals in phylum Aschelminthes.

10.5 SUMMARY

The Aschelminthes are bilaterally symmetrical, pseudocoelomate animals. These are free living and parasitic. These are small vermiform and unsegmented animals. Anterior end lacks a distinct head. Development may be direct or indirect.

10.6. CHECK YOUR PROGRESS — MODEL ANSWERS

1. Pseudocoelom

10.7 MODEL EXAMINATION QUESTIONS

I. Answer the following in about 30 lines.

1. Mention the different classes of phylum Aschelminthes along with examples and give general characters of Rotifera.

II. Answer the following in about 10 lines

1. How does the Nematomorpha differ from other classes?
2. Describe the general characters of Nematoda.

UNIT-II IMPORTANT NEMATODE PARASITES

Contents

- 11.1 Objectives
- 11.2 Introduction
- 11.3 *Ascaris lumbricoides*
 - 11.3.1 Life cycle
 - 11.3.2 Pathogenicity
 - 11.3.3 Control
- 11.4 *Ancylostoma duodenale*
 - 11.4.1 Life-cycle
 - 11.4.2 Pathogenicity
 - 11.4.3 Control
- 11.5 *Wuchereria bancrofti*
 - 11.5.1 Life cycle
 - 11.5.2 Pathogenicity
 - 11.5.3 Control
- 11.6 *Dracunculus medinensis*
 - 11.6.1 Life cycle
 - 11.6.2 Development of embryos in cyclops
 - 11.6.3 Entrance into man and development of adult worms.
 - 11.6.4 Control
- 11.7 Parasitic Adaptations of Helminths
- 11.8 Summary
- 11.9 Check Your Progress - Model Answers
- 11.10 Model Examination Questions

11.1 OBJECTIVES

This deals with the general morphology of parasites of human and veterinary importance. Life-cycles, diseases and control methods are discussed. This also deals with the host parasitic relationship.

At the end of this unit you will explain with confidence that how the nematode parasites infesting man and domestic animals, cause a heavy damage to the economy of a country and in what way they have to be controlled effectively.

11.2 INTRODUCTION

1. Nematodes are **bilaterally symmetrical, triploblastic pseudocoelomate metazoans**.
2. Body of a typical nematode is long, cylindrical, tapering more or less at both the ends.
3. It is enclosed in a very tough impermeable transparent or semitransparent cuticle. Sometimes the cuticle has bristles, spines, ridges or expansions of various kinds.
4. Some parasitic forms have papillae in the head and tail regions.
5. In *Strongylata* the posterior end of male has a bell-shaped expansion called **bursa**.
6. The mouth is surrounded by three lips in the majority of nematodes. In some, lips are absent or modified into **buccal capsule**.
7. The digestive canal consists of mouth, buccal cavity, oesophagus, pharynx and intestine.
8. Nervous system consists of a "**nerve-ring**" from which longitudinal nerves run forward and backward. Special sense organs, **amphids** are present.
9. The Excretory system is variable. The only constant feature is a pore opening on the mid-ventral surface in the oesophageal region.

10. With few exceptions, parasitic nematodes have separate sexes which are externally distinguishable.
11. The male system consists of a single tubular testis, a vas deferens, a seminal vesicle, opening into cloaca.
12. Males normally have a pair of epicules near the cloaca which guide the sperms into the vagina during copulation.
13. Female system consists of two ovaries and two uteri which unite to form vagina. Vagina opens on ventral side mostly in the middle by means of female opening.

The life histories and pathogenicities of the following important parasites are described below:

11.3 ASCARIS LUMBRICOIDES

Common name: Common round worm

It is the largest nematode parasite in the intestine of man.

Phylum	-	Aschelminthes
Class	-	Nematoda
Order	-	Rhabditida
Genus	-	<i>Ascaris</i>
Species	-	<i>A-lumbricoides</i>

11.3.1 Life-cycle

The worm passes its life-cycle in one host. No intermediate host is required. Man is the only known definite host of *Ascaris lumbricoides*. The eggs liberated by fertilised female pass out with the human faeces. They are round or oval in shape. They are 60-75 microns in length, by 40-50 microns in breadth. The eggs are brownish in colour and contain an unsegmented ovum. They are not infective to man when freshly passed. In soil a rhabditi form larva is developed from the unsegmented ovum within the egg shell in 10 to 40 days time. This depends on the atmospheric temperature and humidity. The ripe egg containing the coiled up embryos is infective to man. Before hatching, the larva undergoes moulting.

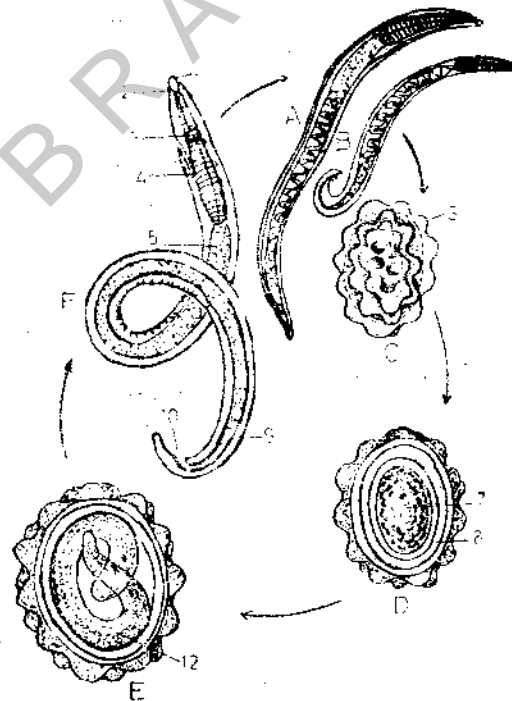

Fig. 11.1 Life history of *Ascaris*. A. Adult male, B. Adult female, C. Entire egg, D. Egg in section, E. Embryonated egg, F. Larva, 1. Mouth, 2. Buccal cavity 3. Nerve ring, 4. Pharynx 5. Intestine 6. Outer layer 7. Zygote 8. Chitinous shell 9. Rectum 10. Anus 11. Tail 12. Juvenile

When ingested (taken) with food, drink or raw vegetables, the embryonated eggs pass down to the duodenum. In the duodenum the digestive juices weaken the egg shell, stimulates the enclosed larvae and makes them active. Then the egg-shell ruptures and the rhabditiform larvae are liberated in the upper part of the small intestine. The larvae liberated in the small intestine do not directly develop into mature worms. The newly hatched larvae burrow their way through the mucous membrane of the small intestine. Then the larvae are carried through the blood medium to the liver. Here they live for a period of 3 to 4 days. Finally they pass out of the liver via the right-heart pulmonary circulation. In lungs they grow much bigger and increase in length from 0.2 mm to 2 mm. Here larva moults twice (first on the 5th or 6th day and the second after the 10th day). Now they reach the lung alveoli. The time taken for this migration is on an average 10 to 15 days. From the lung alveoli the larvae crawl up to bronchi and trachea. The ciliated epithelium of the respiratory tract causes the current due to which the larvae are thrown into larynx and pharynx and are once more swallowed. The larvae pass down the oesophagus to stomach. They settle down in the upper part of the small intestine. The intestine is the normal dwelling place of these worms. After infection between 25th and 29th day another moulting occurs. In the intestine they grow into adult worms. They become sexually mature in about 6-10 weeks time. the gravid females begin to discharge eggs in the stool within two months from the time of infection. The cycle is again repeated. (Fig. 11.1).

11.3.2 Pathogenicity

1. Pathogenicity of *Ascaris* depends on severity of infection.
2. Presence of few individuals generally has no serious effect on the host's health.
3. Heavy infection is however serious. It causes weakness and anaemia.
4. Toxins produced by the parasites cause irritation of intestinal mucosa and weakens the digestion. Colic pain may also result.
5. The worms sometimes damage the mucous membrane, cause the enteritis (bowel inflammation) and peritonitis.
6. During migration of larvae through lungs and bronchioles, irritation, intense coughing, haemorrhage and inflammation leading to pneumonia occurs.
7. Sometimes during general circulation larvae reach kidneys, brain, spinal cord, and muscles and cause serious lesions.
8. About 100 worms are known to destroy the intestine completely.
9. They also cause appendicitis and hepatitis.

11.3.3 Control

1. Dispersal of human faeces by underground sewage system is an efficient method to control *Ascaris* infection.
2. Infection of *Ascaris* can be prevented by thoroughly washing vegetables and fruits before eating.
3. Teaching children early in life to wash hands before meals, is a best controlling method.
4. Adult worms can be removed by giving the patient a mixture of oil of *Chenopodium* and Tetrachloroethelene.
5. Hetrazone syrup is also effective and non-toxic specially to children.
6. Piperzine, hydrate, Alcopar and Banocida are also recommended as antihelminthic

11.4 ANCYLOSTOMA DUODENALE

Common name: The old world hook worm

The adult worm lives in the small intestine of man. The eggs are first laid in an unsegmented stage. During their passage through the bowel, segmentation occurs upto the 4-celled stage. The eggs when passed out with the faeces are not infective to man.

11.4.1 Life cycle

No intermediate host is required. Like other helminthes, multiplication of worms does not occur

inside the human body.

Man is the only definitive host of *Ancylostoma duodenale*. The eggs containing segmented ova are passed out in the faeces of the human host. From each egg, a 'rhabditiform larva' hatches out in the soil in about 48 hours. The larva is 250 microns in length.

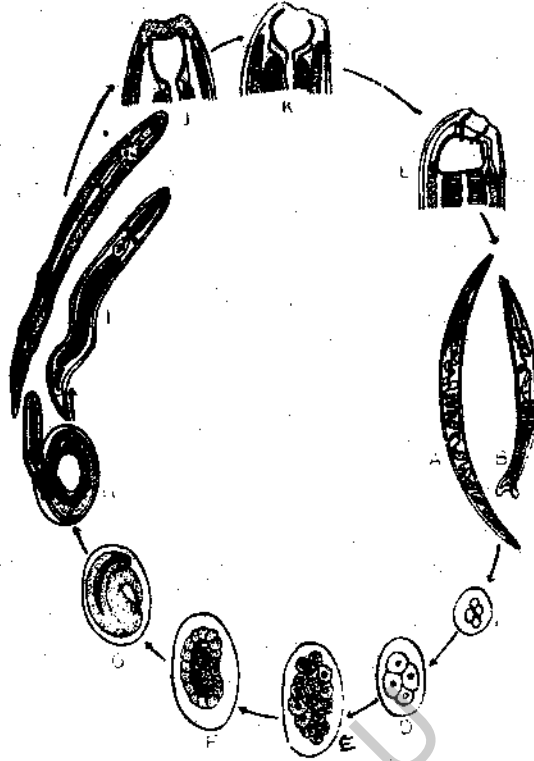

Fig. 11.2. Life-cycle of *Ancylostoma duodenale*. A. Adult female. B. Adult male C. Eggs escaping in faeces D-G: Development of egg in soil (24 to 48 hours) H. Rhabditiform larva moults thrice (3rd and 4th day). I. Filaria from larva (in 8 to 10 days). J. With terminal buccal capsule (3rd moult). K. Provisional buccal capsule on arrival in intestine. L. An adult with defective buccal capsule.

The rhabditiform larva moults twice on the third day and the fifth day. It then develops into a 'filariform larva' which is the infective stage of the parasite. The filariform larva is 500 to 600 microns in length. The time taken for development from eggs to filariform larva is on an average 8 to 10 days. The larvae cast off their sheaths and enter the body by penetrating the skin. On reaching the subcutaneous tissue the larvae enter into lymphatics and small venules. Then they enter via the right heart into the pulmonary capillaries. Breaking through the capillary walls the worms enter into alveolar spaces, then they migrate on to the bronchi, tracheae and larynx. Afterwards they crawl over the epiglottis to the back of the pharynx and are ultimately swallowed. During migration or on entering the oesophagus a third moulting takes place and a terminal buccal capsule is formed. For such migration it takes about 10 days. The growing larvae settle down in the small intestine, undergo a 4th moulting and develop into young worms. At this stage the toothless buccal capsule formed previously is cast off and a definitive buccal capsule with complete teeth is formed. In three to four weeks time they are sexually mature and the fertilized females begin to lay eggs in the faeces.

The cycle is thus repeated. The interval between the time of skin infection and the first appearance of eggs in the faeces is about six weeks. (Fig. 11.2)

11.4.2 Pathogenicity

1. The worm causes hookworm disease or *Ancylostomiasis*. It is characterised chiefly by anaemia.
2. This occurs when man walks bare-foot in the faecally contaminated soil. This disease is responsible for considerable economic loss as well as poor health.
3. The filariform larvae penetrate directly through the skin with which they come in contact.

4. The penetrating larvae cause tiny, irritating sores or ground itching and inflammation of skin.
5. Adults in the intestine cause stomach pain, diarrhoea, palpitation of heart and collapse.

11.4.3 Control

1. Several drugs such as oil of chenopodium, carbon tetrachloride, Hexylresorcinol are used to cure the disease and to remove worms from the body.
2. The most commonly recommended drug is Tetrachloroethylene because it is very efficient and less poisonous.
3. Proper hygienic measures and sanitary education should be given to the people and especially to children who must be taught to wash hands before every meal.
4. Every home should be provided with sanitary toilet. The human faeces should be disposed off by an underground sewage system.

11.5 WUCHERERIA BANCROFTI

Synonym: *Filaria bancrofti*

(Common name: Bancroft's filaria)

The females are ovo-viviparous i.e. they lay eggs with well developed embryos. These embryos are called **microfilariae**. The microfilariae are very active and can move in blood stream. When unstained, they appear as colourless and transparent bodies with blunt heads and rather pointed tails. The embryo measures about 290 microns in length by 67 microns in breadth. It consists of a hyaline sheath, nuclei and a few G-cells or genital cells. (Fig. 11.3)

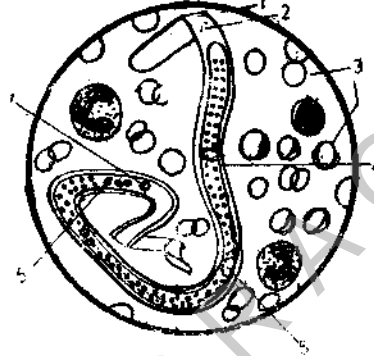

Fig. 11.3. *Wuchereria bancrofti* larva stage (microfilaria). 1. Microfilaria 2. Sheath 3. Red blood corpuscles 4. Nerve ring 5. Excretory pore 6. G-Cells (2-4) 7. Anal pore.

The larval forms do not undergo any further development in the human body unless they are taken up by the proper intermediate host (culex mosquito). If these microfilariae are not sucked up by the mosquito, they die in course of time. The life-span of microfilariae in the human body is about 70 days. The microfilariae appear periodically at night mostly between 10PM and 4 AM. This shows **nocturnal periodicity**.

11.5.1 Life cycle

The life-cycle passes in two hosts, man and mosquito. Man is the definitive hosts. The adult worms live in the lymphatic system of man. Live embryos (microfilariae) are discharged and enter the blood stream. These embryos are capable of living in the peripheral blood for a time without undergoing any change. These are subsequently taken up by the female culex mosquito during their blood meal.

The intermediate host is mosquito belonging to the genus, *Culex*. In mosquito the microfilariae undergo further development. After that they become infective to man. Sheathed microfilariae ingested by the mosquito collect round the anterior end of the stomach. They cast off their sheaths quickly, penetrate the gut wall within an hour or two and migrate to the thoracic muscles. Here they rest and begin to grow. In the next two days the slender organism changes to a thick short, sausage-

shaped form with a short spiky tail which measures 124 to 250 microns in length by 10 to 17 microns in breadth (the first stage larva). It possesses a rudimentary digestive tract. In 3 to 7 days time the larva grows rapidly, moults (sheds cuticle) once or twice. Now this is called the second stage larva. It measures 225 to 330 microns in length by 15 to 30 microns in breadth.

On the 10th or 11th day the metamorphosis becomes complete. The tail reduces to a mere stump. The digestive system, body cavity and genital organs are now fully developed. This is the third stage larva, which measures 1500 to 2000 microns in length by 18 to 23 microns in breadth. At this stage, it is infective to man and enters the proboscis sheath of the mosquito on or about the 14th day. One microfilariae gives rise to one infective larva in the proboscis sheath.

When the infected mosquito bites, the third stage larvae penetrate the skin and reach the lymphatic channels. They settle down at some spot (inguinal, scrotal or abdominal lymphatics) grow into adult forms. In course of time, probably after a period of 5 to 18 months they become sexually mature. The male fertilises the female and gravid females give birth to larvae. A new generation of microfilariae is emitted which pass either through the thoracic duct or the right lymphatic duct to the venous system and pulmonary capillaries and then to peripheral circulation thus completing the cycle.

11.5.2 Pathogenicity

1. Heavy infection of the filarial worms block the lymph vessels.
2. Lymph accumulates in the affected part and causes the swelling of that part.
3. This disease is called **elephantiasis** or **filariasis**.
4. Usually arms, legs, scrotum and mammary glands are affected.

11.5.3 Control

1. Protection from mosquitoes prevent the infection of *Wuchereria bancrofti*.
2. Destruction of mosquitoes controls the infection.
3. Treatment of carriers by using Hetrazon.

11.6 DRACUNCULUS MEDINENSIS

Common name: Guinea worm, serpent worm or dragon worm, medina worm.

The adult females are usually found in the subcutaneous tissues, specially of the legs, arms and back.

The male worm has not yet been recovered from man (except a case from India). But the male has been recovered from experimental animals. (Fig. 11.4)

11.6.1 Life-cycle

The worm passes its life-cycle in two hosts, man and cyclops.

1. **Definitive host:** The adult parasite lives in the subcutaneous tissue of man.
2. **Intermediate host:** Cyclops, in which the embryos undergo certain developmental changes before they become infective to man.

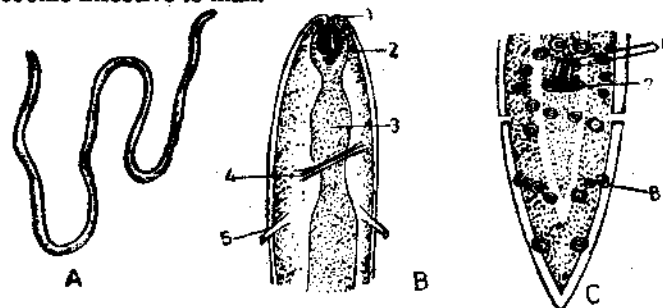

Fig. 11.4 *Dracunculus medinensis*. A. complete adult worm. B. Anterior end of male c. Tail end of male (ventral view). 1. Cephalic lip 2. Pharynx (muscular) 3. Pharynx (glandular) 4. Nerve ring 5. Cervical papillae 6. Penial spicules 7. Anus 8. Postanal genital papillae.

11.6.2 Development of embryos in Cyclops

Each Cyclops can ingest as many as 15 to 20 *Dracunculus* embryos. The infected Cyclopes usually die at the end of 42 days, but when they are infected heavily, they do not live for more than 15 days, (normal life-span of cyclops is about 3 months).

The embryos penetrate the gut wall within 1 to 6 hours after ingestion and enter the body cavity of the Cyclops, where they undergo metamorphosis and increase in size. Under favourable conditions it takes about 2 weeks for the complete development.

11.6.3 Entrance into man and development of adult worms

The cyclops containing the infective larvae are swallowed by man with unfiltered drinking water. On reaching the stomach the cyclopes are digested by the gastric juice and the larvae are liberated. They then penetrate through by the gut wall and enter the connective tissues. Where they grow to sexual maturity. The larvae in man become adult males and females. The males die after fertilizing the females and disappear within 6 months after infection. The union between males and females occur early in the deeper connective tissues and not in the intestine. It takes about another six months for the gravid females to select its site for discharging the embryos in water. The gravid females migrate and selects only those parts of the skin which are liable to come in contact with water such as arms and legs. (e.g. arms and legs of washerman, and legs of those who fill water in containers in step walls and ponds). On reaching the skin surface, it secretes a toxin, producing a blister which later ruptures and forms an ulcer. Contact with water stimulates the worm to protrude its head through the centre of ulcer and causes a discharge of milky fluid containing a large number of coiled embryos ejected from the uterus. Thus the embryos are back again in water and the cycle is repeated.

11.6.3 Pathogenicity

1. *Dracunculus* causes guineaworm disease, characterised by asthma, urticaria, itchness, nausea, vomiting, diarrhoea, dysnea and eosinophilia etc.
2. These diseases are caused due to toxic substances produced by the parasite.

11.6.4 Control

The infection can be prevented by the irradiation of cyclops and by drinking filtered or boiled water.

11.7. PARASITIC ADAPTATIONS OF HELMINTHS

The helminths are modified morphologically as well as physiologically to live in their particular environments. These modifications depend on the degree of parasitism.

Morphological adaptations

1. Loss and degeneration of locomotory, digestive and sense organs.
2. As the adult parasites live for their entire life in the body of a single host, the locomotor organs are quite useless, except in the free-living larval stages. such as miracidium and hexacanth in which the ectoderm become ciliated.
3. As the parasites live on digested or semidigested food of the host, there is a reduction in the alimentary canal and digestive glands.
4. The sensory organs of helminths are also simple due to the parasitic mode of life.
5. The outer integument or cuticle of parasites becomes highly modified and adapted to resist against digestive juices.
6. The well-developed musculature in cestoda enables them to adjust their long body in the intestine of the host.
7. Helminths are variously modified for adhesion to the body of the hosts. Suckers are formed in all adult parasitic flat worms. In tape worms the scolex bears either sucking cups or accessory suckers or lateral sucking grooves or bothria.

In some cestodes and nematodes, hooks or hook like structures also develop near the cephalic end which further help in the attachment.

8. Reproductive organs show significant development and adaptation to parasitism. There is a vast increase in the reproductive capabilities by producing large number of eggs.
9. Life-history usually includes several larval stages for multiplication and for easy and sure transfer from one host to another.

Physiological adaptations

1. The flukes feed on tissue elements and have probably intra-cellular digestion.
2. The osmotic pressure of the interior of the parasitic worms remain less than or same as that of their hosts, so that there is no difficulty in exchange of water.
3. The intestinal parasites live in an environment completely devoid of free oxygen. Their evolutionary adaptation has resulted in a very low metabolic rate which requires a minimum amount of oxygen.
4. Most of the helminth parasites, particularly intestinal parasites, secrete, anti-enzymes in order to protect themselves from gastric juices and digestive enzymes of the host.

Check Your Progress

1. Many Intestinal nematode parasites of man have similar life cycles. Common route which they adopt starting from intestine is as follows: Intestine _____, _____, _____, _____, _____, _____, _____ and intestine .
2. Common antihelminthic drugs to control are _____, _____.
3. Intestinal parasites secrete antienzymes in order to protect themselves from the _____ secretions of the host.

11.8 SUMMARY

The nematodes are popularly known as round worms. They occur in all habitats such as moist soil, fresh water, sea water, plants, animals and man. Sexes are mostly separate. Males are smaller than females. Hermaphrodite and parthenogenetic forms are also known. Fertilization is internal development is direct and indirect.

11.9 CHECK YOUR PROGRESS — MODEL ANSWERS

1. liver, heart, lungs, bronchi, trachea, larynx, glottis, epiglottis, pharynx, oesophagus, stomach
2. hexazon, Tetrachloroethylene.
3. digestive.

11.9 MODEL EXAMINATION QUESTIONS

- I. Answer the following in about 30 lines.
 1. Describe in detail the life cycle of *Ascaris*.
 2. Describe the life cycle of *wuchereria bancrofti* and a note on its pathogenicity.
 3. Describe the life cycle of *Dracunculus medinensis* and add a note on its pathogenicity.
 4. Mention important morphological and physiological adaptations of Helminths.
- II. Answer the following in about 10 lines.
 1. Describe the pathogenicity of *Ascaris* and add a note on its control methods.
 2. Describe briefly the life cycle of *Ancylostoma duodenale*.

UNIT-12 ANNELIDA-GENERAL CHARACTERS AND CLASSIFICATION

Contents

- 12.1 Objectives
- 12.2 Introduction
- 12.3 General Characters
- 12.4 Classification
 - 12.4.1 Class - Polychaeta
 - 12.4.2 Class Archiannelida
 - 12.4.3 Class - Oligochaeta
 - 12.4.4 Class - Hirudinea
- 12.5 Summary
- 12.6 Check Your Progress — Model Answers
- 12.7 Model examination Questions

12.1 OBJECTIVES

In this unit the characters of phylum Annelida and its classes are described to explain to the students that the members of the phylum have many characters in common. You derive after finishing this unit the concepts of metamerism, schizocoel and closed circulatory system and explain their importance in the progress of animals.

12.2 INTRODUCTION

It was a common practice in the earlier periods to include all soft bodied animals in group called 'Vermes'. This group vermes, therefore, included animals like the parasitic worms, a few arachnids and crustaceans. However, Lamarck in 1809 gave the name Annelida to the phylum on the basis of ring - like, segmented body, (Lat, annulus: a little ring; Gr. eidos : form)

12.3 GENERAL CHARACTERS

1. Annelids are multicellular, triploblastic, bilaterally symmetrical, coelomate worm-like animals.
2. The body is divided into a number of ring-like segments or metameres. The segments are separated from each other externally by grooves and internally by septa. The segmentation is known as true metamerism.
3. There is a single pre-oral segment called **prostomium**. The anus is in the anal segment called the **pygidium**. In between, mostly the segments are similar.
4. The body wall has a thin, transparent, non-cellular covering the cuticle. It is produced by the epidermis.
5. The epidermis is single layered with different types of cells and chitinous structures known as **setae**.
6. The body wall and the alimentary canal contain circular and longitudinal layers of muscles.
7. The body cavity is a **true coelom**. The space is lined on either side by the epithelium derived from the mesoderm. It is filled with a fluid called the coelomic fluid. The coelom acts as a hydraulic skeleton as the coelomic fluid is incompressible. However, in leeches the coelom is reduced.
8. The chitinous setae help in locomotion. In polychaetes the setae are seen in tufts in special locomotor organs called parapodia. In leeches setae are absent, so the locomotory function is taken up by the suckers.
9. Digestive system is well developed. The alimentary canal is a straight tube. It is differentiated

into well defined regions. Pharyngeal glands and in a few animals intestinal glands are also found. In leeches the alimentary canal is divided into two parts - a storage part and a digestive part.

10. Blood is red in colour due to the presence of haemoglobin dissolved in the plasma. Blood flows in closed blood vessels. So the blood vascular system is of the **closed type**.
11. Special respiratory organs are absent. The skin acts as the respiratory organ. It is slimy and moist. It is also richly supplied with blood vessels.
12. Excretory system consists of paired highly coiled **nephridia** in each segment. In some these are minute in size and large in number in each segment.
13. Nervous system consists of paired cerebral ganglia or brain located on the dorsal surface of the pharynx. A nerve ring is formed by a pair of circumpharyngeal connectives. The ventral nerve cord which extends throughout the length of the body has ganglia and nerves in each segment. The nerve cord is paired and solid.
14. Sense organs consist of tactile organs, taste buds, eyes etc.
15. Most of the annelids are **monoecious**. Sexes are separate in polychaetes.
17. Development is direct or indirect. In indirect development there is a larval stage known as **trochophore** or trochosphere. In some there is a sexual reproduction by budding.
17. Cleavage of the egg is **spiral and determinate**
18. A few animals exhibit regeneration.

Annelids are marine, freshwater and terrestrial forms. Most of them are free moving, a few live in burrows. A few others lead an ectoparasitic life.

12.4 CLASSIFICATION

The phylum is divided into four classes. These are 1) Polychaeta, 2) Archannelida, 3) Oligochaeta and 4) Hirudinea.

12.4.1 Class: Polychaeta

Polychaet worms (Gr. Poly: many; Chaeta: bristles) are very common marine animals. These constitute the largest class of the phylum Annelida. There are about 5,000 species. The distinguishing features of the class are:

1. Most of the polychaetes are perfectly **metameric** with a cylindrical body.
2. Head consists of **prostomium** and **peristomium** and bears eyes, tentacles, cirri and palps.
3. The presence of **parapodia** in each segment is the most distinguishing feature of the class. These are paired and lateral.
4. The last segment is the **pygidium**.
5. The body wall is dermomuscular with a thin, tough, chitinous non-cellular **cuticle** covering the body externally.
6. The coelom is an extensive cavity divided into compartments by transverse septa. The coelomic fluid gives turgidity to the body. It acts as a hydraulic skeleton.
7. Alimentary canal is provided with an **eversible buccal region** and **protrusible pharynx**.
8. Respiration is by the skin. It is known as **cutaneous respiration**.
9. **Closed type** of blood vascular system is present.
10. Excretory organs are paired **nephridia** which are segmentally arranged.
11. Nervous system typically annelidan.
12. Sexes are separate (**dioecious**).
13. Gonoducts are absent. Fertilization is external.
14. Development is **indirect**. A free swimming **trochophore** larva is formed.
15. Asexual reproduction takes place by lateral budding.

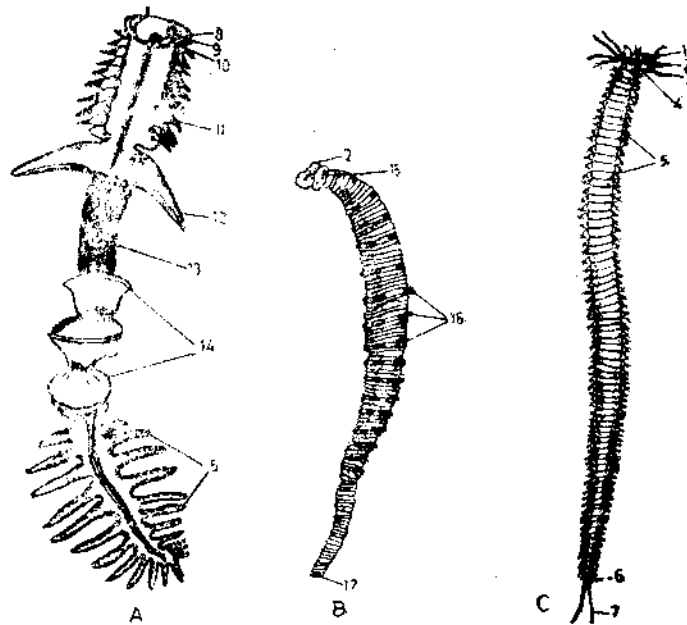

Fig. 12.1. Representatives of Polychaeta. A. Chaetopterus. B. Arenicola. C. Nereis. 1. Prostomial palp. 2: Prostomium. 3. Peristomium. 4. Eyes. 5. Parapodia. 6. Pygidium. 7. Anal cirri. 8. Mouth. 9. Prostomial collar. 10. Peristomial tentacle. 11. Notopodia. 12. Great wing. 13. Food cup. 14. Fans. 15. Protruded pharynx. 16. Gills. 17. Anus.

e.g. *Chaetopterus* (Fig. 12.1 A) - Clam worm, Sandworm, Rag worm, *Arenicola* (Lug worm or Lobe worm) (Fig. 12:1.B) *Neanthes (Nereis)* (Fig. 12.1C)

12.4.2 Archiannelida

Archiannelids are a heterogeneous group. These are nowadays treated as a separate minor phylum. The degenerate characters of the group are not believed to be primitive. These are now thought to be secondarily acquired due to burrowing mode of life.

The salient features of the class are:

1. These are small marine worms without clear external segmentation.
2. The prostomium is small, and the peristomium is large.
3. Parapodia, setae and suckers are absent.
4. There is a single pair of prostomial tentacles.

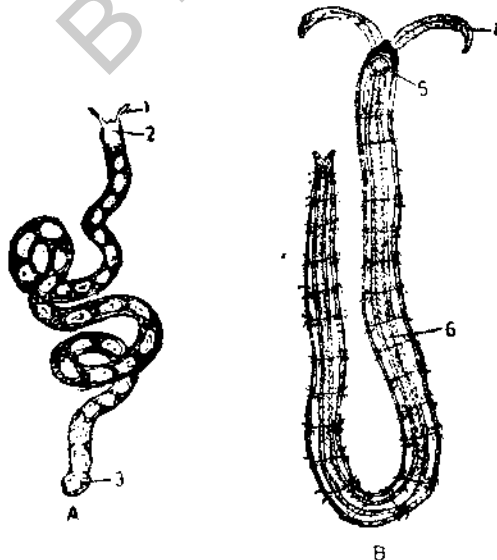

Fig. 12.2 Representatives of Archiannelida. A. Polygordius. B. Protodrilus
1. Tentacle, 2. Peristomium, 3. Anal-gement, 4. Prostomia, tentacles,
5, Oesophagus, 6. Intestine

5. A cirlet of adhesive papillae is present around the anus in *Polygordius*. A ventral ciliated groove is present in *Protodrilus*.
6. The body cavity is divided into number of compartments by transverse septa.
7. The circulatory system consists of a dorsal and ventral blood vessel extending from the anterior to the posterior end.
8. There is a pair of simple nephridia in each segment. They may be closed nephridia with solenocytes or they may be with nephrostomes opening into the coelom.
9. Sexes are separate in *Polygordius*. *Protodrilus* is hermaphrodite. There are no special gonoducts.
10. Development is indirect. The larva of *Polygordius* is known as Loven's larva.
e.g. *Polygordius* (Fig. 12.2.A)
Protodrilus (Fig. 12.2.B)

12.4.3 Class: Oligochaeta

The class Oligochaeta (Oligos: a few; Chaeta: setae) consists of about 3,000 species. These include the familiar earthworms. These animals have typical segmentation. Externally the body does not show any special organisation. The animals are of variable length. Some fresh water forms measure only 0.5 mm while a few earthworms are of giant size reaching 3-4 m long.

The class has the following characters:

1. Animals belonging to this class are terrestrial or live in burrows in the moist soil.
2. Head, eyes tentacles and parapodia are absent.
3. Segmentally arranged chitinous setae are present. The setae are usually S-shape with a swollen middle portion called the nodulus. The number and arrangement of setae vary from animal to animal.
4. In mature earthworms segments in a portion of the body are thickened. In this region the segmentation is not distinct. It is known as clitellum. The epidermal glands in the clitellar region secrete mucus. The mucus secretion help in copulation and also in the formation of cocoon.
5. The body wall is typically dermomuscular. The epidermis secretes a thin layer of cuticle. Circular and longitudinal layer of muscles are well developed.
6. The body cavity is a true coelom. The cavity is lined by coelomic epithelia which are developed from the mesoderm. The epithelium lining the body wall is known as the somatic or parietal layer. The epithelium lining the alimentary canal is known as the visceral or splanchnic layer. Transverse septa divide the cavity into number of compartments corresponding to the external segmentation. The coelomic cavity communicates with the outside by openings known as dorsal pores. The fluid oozes out of the pores and keeps the skin moist.
7. Locomotion is by the alternate contraction and relaxation of circular and longitudinal muscles.
8. The digestive system is well developed. It consists of alimentary canal and pharyngeal glands. The alimentary canal is organised into different regions. The pharynx is eversible. The intestine has internally a mid-dorsal fold called the typhlosole. It increase the surface area of absorption.
9. Respiration is performed by the skin. It is slimy and moist. The skin is supplied with large number of blood vessels.
10. Blood vascular system is of the closed type. Dorsal and ventral blood vessels and lateral hearts are present.
11. Excretory organs are nephridia. These are minute coiled tubules. Aquatic oligochaetes excrete ammonia. Terrestrial forms excrete urea. Chloragogen cells form a layer around the intestine. These are yellow cells derived from the inner coelomic epithelium. These cells play a vital role in the intermediary metabolism, similar to that of liver in vertebrates.

12. Nervous system is typically annelidan. A brain, nerve ring and ventral nerve cord are present.
13. Sense organs poorly developed. When present these are the modified epidermal cells.
14. Oligochaetes are hermaphrodites. The gonads are distinct with gonoducts. The reproductive cells mature in seminal vesicle and ovisac.
15. Oligochaetes copulate for mutual exchange of spermatozoa. The ventral surfaces of the copulating worms are in contact in such a way that the anterior end of one worm is directed towards the posterior end of the other worm.
16. After copulation the clitellum secretes a cocoon. The eggs and spermatozoa are discharged into the cocoon as it slips over the animal.
17. Fertilization takes place within the cocoon.
18. The young ones emerge from the cocoon after hatching.
19. Asexual reproduction is common among aquatic oligochaetes
20. The power of regeneration is fairly high in oligochaetes.

e.g. : *Megascolex* sp. (Earthworm)

Tubifex (freshwater) - inhabits the bottoms of deep lakes (Fig. F) 12.3.A

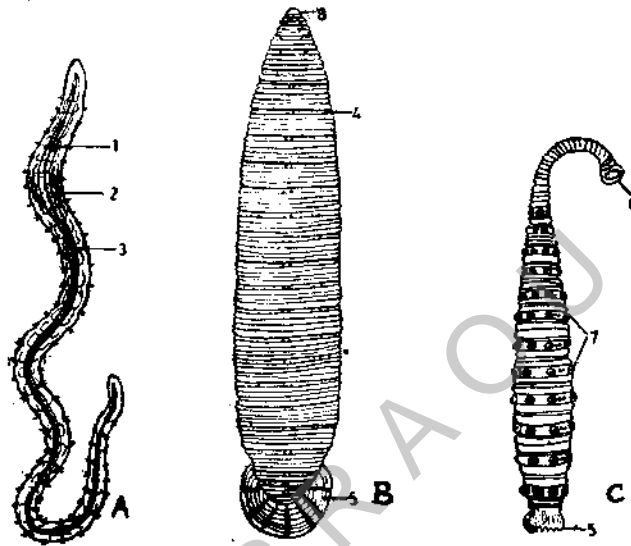

Fig. 12.3 Representatives of Oligochaeta and Hirudinea. A *Tubifex*. B *Hirudinaria*. C *Pontobdella* 1. Nerve ring. 2. Blood vessel. 3. Intestine 4. Segmental receptors. 5. Posterior sucker. 6. Anterior sucker. 7. Warts. 8. Prostomium.

12.4.4 Class: Hirudinea

The class Hirudinea contains about 500 species of freshwater, marine and terrestrial worms. These include the familiar leeches which are sanguivorous. The hirudineans resemble the oligochaetes in many characters. These resemblances suggest a common ancestry.

The salient features of the group are:

1. The body of leeches is typically dorso-ventrally flattened.
2. The segments at both the ends are modified to form suckers. The anterior sucker in most of the leeches is cup-shaped. The posterior sucker is disc shaped.
3. The number of segments is reduced. It is also specific to different species. Usually the number is 32-34.
4. Each segment is again divided into number of annuli. The number of annuli per segment varies.
5. The body of the leech is divided into 5 imaginary parts. These are cephalic, preclitellar, clitellar, middle region, caudal region and the region of the posterior sucker.
6. Clitellum is mostly seen in segments 9, 10 and 11. It develops only during the breeding seasons.
7. The head bears 5 pairs of eyes.

8. Parapodia and setae are absent. Leeches of the order *Aeanthobdellida* only possess setae.
9. The body wall has a prominent layer or dermis. In addition to the circular and longitudinal layers of muscles an oblique layer is also present.
10. The leeches differ from the other annelids in the loss of coelom. This is due to extensive growth of connective tissue. The coelom, therefore, is reduced to small spaces or sinuses or channels. In the genus *Hirudo* and allied leeches a massive growth of tissue called botryoidal tissue reduces the coelom.
11. In many leeches the digestive system is organised to suit to the blood sucking ectoparasitic life. The alimentary canal has two parts a storage part and a digestive part.
12. The saliva of a few leeches contain an anticoagulant called **hirudin**
13. There are no special respiratory organs in leeches. Like the other annelids skin performs cutaneous respiration.
14. Excretory organs are nephridia. These are 10 to 17 pairs, lying one pair per segment.
15. Ammonia is the chief excretory product.
16. As in the other annelids the nervous system consists of a brain, nerve ring and ventral nerve cord with segmental ganglion.
17. Like oligochaetes, leeches are also hermaphrodites. Gonads and genital ducts have fixed positions.
18. The sperm exchange between two leeches takes place in the same way as in oligochaetes.
19. Fertilization takes place within the ovisacs. Fertilized eggs are discharged into the cocoon. The clitellum forms the cocoon.
20. Development is direct and there is no larval stage.

e.g.: *Hirudinaria granulosa* (Indian cattle leech) (Fig. 12.2.B) *Pontobdella* (Skate-sucker) (Fig. 12.3)
C. *Branchellion* (Marine leech)

Check Your Progress

1. Extensive true coelom is the characteristic feature of all annelids but it is much reduced in leeches because of tissue.
2. All organ systems except system have fully developed in all annelids.
3. Trochophore larva is characteristic of both and

12.5 SUMMARY

These are segmented bilaterally symmetrical worm-like animals. The body wall is dermomuscular with chitinous setae. The body cavity is a true coelom filled with coelomic fluid. Blood vascular system is of closed type. Nephridia are the excretory organs. Nervous system is typical intervertebrate type. Most of the animals are monoecious. Trochophore or trochosphere is the characteristic larval form. The phylum is divided into four classes. Class Polychaeta includes exclusively marine forms. class Archiannelida includes a few specialised aberrant forms. Earthworms are included in the class oligochaeta. Leeches are the examples of class Hirudinea.

12.6 CHECK YOUR PROGRESS — MODEL ANSWERS

1. botryoidal
2. respiratory
3. Annelids, Molluscs.

12.7 MODEL EXAMINATION QUESTIONS

I. Answer the following in about 30 lines:

1. Give an account of the general characters and classification of phylum Annelida upto classes.
2. Describe the characteristic features of the class Oligochaeta and in what respect it differs from the class Hirudinea.

II. Answer the following in about 10 lines

1. Describe the general characters of the class Polychaeta along with few examples.
2. Write briefly Archiannelids.
3. How will you classify *Arenicola*, *Pheretima*, *Acanthobdella* and *Polygordius*?

UNIT - 13 NEREIS

Content

- 13.1 Objectives
- 13.2 Introduction
- 13.3 External Characters
- 13.4 Body wall
- 13.5 Coelom
- 13.6 Locomotion
- 13.7 Digestive System
- 13.8 Respiration
- 13.9 Blood Vascular System
- 13.10 Excretory System
- 13.11 Nervous System
 - 13.11.1 Sense Organs
- 13.12 Reproductive System
 - 13.12.1 Development
 - 13.12.2 Heteroneries
- 13.13 Summary
- 13.14 Check Your Progress — Model Answers
- 13.15 Model Examination Questions
- 13.16 Glossary

13.1 OBJECTIVES

In this unit *Nereis* is described in detail so as to acquaint with the organisation of a coelomate, metameric, bilaterally symmetrical animal which you will be able to explain lucidly at the end.

13.2 INTRODUCTION

Nereis is the common sandworm or clamworm. It occurs buried in sand along with bivalves. These live in intertidal zone of the sea, usually hidden under the stones or sea weeds. The name *Nereis* is now replaced by *Neanthes*. The common species are *N. dumerilli*, *N. diversicolor*, *N. virens* *N. pelagica* etc.

Systematic Position:

- Phylum : Annelida
- Class : Polychaeta
- Order : Errantia
- Genus : *Neanthes (Nereis)*

Nereis is carnivorous feeding on small insects, molluscs and worms. It is nocturnal. It is world wide in distribution.

13.3 EXTERNAL CHARACTERS

The body of *Nereis* is long, narrow, slender and pointed posteriorly. The upper (dorsal) surface of the body is convex. Ventral surface is somewhat flat. The size varies from species to species. It may reach 30-50 cms. The colour also is different in different species. The cuticle is iridescent.

The body of *Nereis* is divided into head, trunk and pygidium. The trunk is divided into a number of segments or metameres.

Head

The Head consists of two main parts, prostomium and peristomium. Prostomium is not a true segment of the body. It is situated mid dorsally in front of the mouth.

Peristomium is a large segment formed by the fusion of first and second segments. It forms the lateral and ventral margins of the mouth.

Sensory structures of the head

- i) **Prostomial eyes:** (Fig. 13.1 A) Prostomium bears four simple and black eyes on its dorsal surface. These are photoreceptors.
- ii) **Prostomial tentacles:** A pair of short tentacles projects from the anterior border of the prostomium.
- iii) **Prostomial palps:** These are also a pair. These are stout and long. The palps are on the ventral side of the prostomium. Both tentacles and palps are tactile in function.
- iv) **Nuchal organs:** These are ciliated pits of unknown function lying on each side of the prostomium.
- v) **Peristomial cirri:** These are two pairs of thread-like structures. One pair is dorsolateral and the other is ventrolateral. These are homologous to the cirri of the parapodia in the trunk segments. These are tactile in function.

Trunk

The rest of the body which is metamerically segmented is known as the trunk. All the segments of the trunk are similar except the last one.

Pygidium

The last segment of body is called the pygidium or the anal segment. It has the anus. Parapodia are absent but a pair of long cirri are present.

Parapodia

Parapodia are present laterally in all the trunk segments except the peristomium and pygidium.

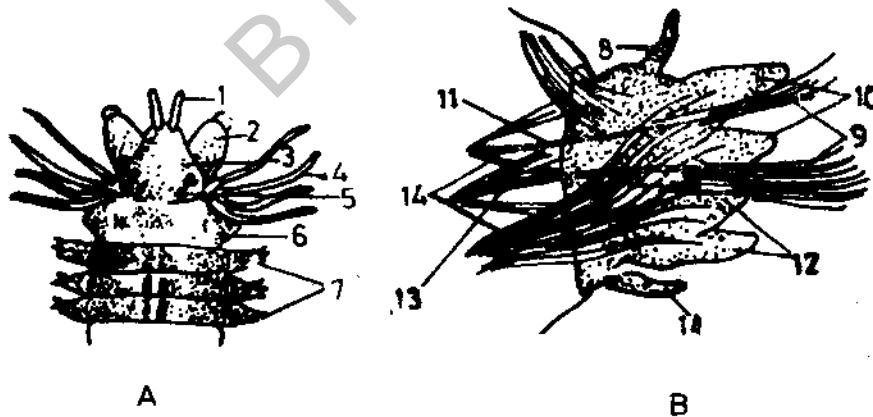

Fig. 13.1. *Nereis*. A. Anterior end. B. Parapodium. 1. Prostomial tentacles. 2. Prostomial palp. 3. Prostomium. 4. Peristomial cirri. 5. Eyes. 6. Peristomium. 7. Parapodia. 8. Dorsal cirrus. 9. Setae. 10. Notopodia. 11. Dorsal aciculum. 12. Neuropodia. 13. Ventral aciculum. 14. Muscles. 15. Ventral cirrus.

Each parapodium (Fig. 13.1 B) is a biramous structure. It consists of two parts. The upper part is known as the dorsal blade or the **notopodium**. The lower part is the ventral blade or the **neuropodium**. Each of these is again divided into two lobes. The notopodium has a short, cylindrical, tactile appendage called the dorsal cirrus. The neuropodium also bears a similar structure known as ventral cirrus. The notopodium is larger than the neuropodium.

Both notopodium and neuropodium have a bundle of bristle like setae. These are lodged in a sac, the setigerous or chaetigerous sac. The setae can be moved in different directions by muscle fibres. Each seta arises from a formative cell present at the base of the setigerous sac.

A long, stout, straight seta known as aciculum is present in each bundle of setae. It does not project out of the bundle. It serves as an endoskeletal structure of the parapodium.

The parapodia are highly muscular. These are primarily organs of locomotion, used for both creeping and swimming. They are highly vascular. So they are believed to be respiratory. Parapodia are large in the middle region.

Setae

Each setae is a two-jointed structure. It has a proximal shaft and a distal blade. The setae are of two types.

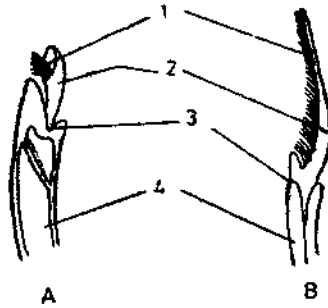

Fig. 13.2 Setae of *Nereis*. A. Typical. B. Long blade. 1. Serrated margin. 3. Joint. 4. Shaft.

i) **Typical seta:** It has a large stout shaft. (Fig. 13.2 A) The blade is short and stout. The tip is notched and curved.

ii) **Long bladed seta:** It has a small shaft. (Fig. 13.2 B) The blade is long, slender, straight and pointed. One edge is serrated.

13.4 BODY WALL

The body wall consists of four layers - (i) cuticle, (ii) epidermis, (iii) muscle layers, (iv) peritoneum. (Fig. 13.3)

Cuticle: It is the outer layer secreted by the epidermis. It is thin, tough, chitinous and non-cellular. It is perforated by a large number of epidermal glands. The cuticle is iridescent.

Epidermis: The epidermis consists of a single layer of columnar epithelial cells. These cells are of three types-glandular cells, sensory cells and supporting cells. The gland cells open by minute openings on the surface of the animal. The epidermis is thick and glandular on the ventral surface. The glands are larger and more numerous in the region of parapodia. The gland cells secrete mucus

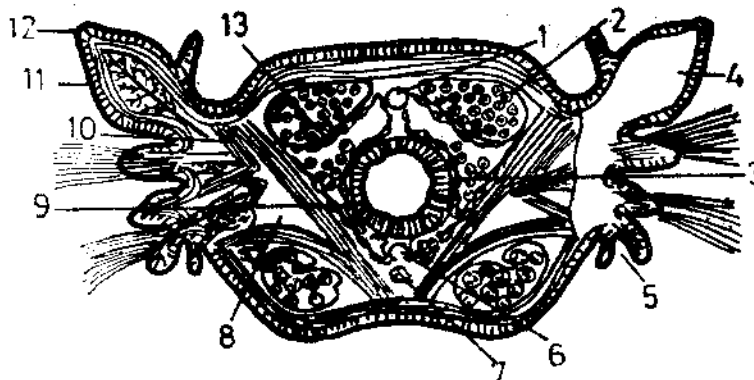

Fig. 13.3. *Nereis* - Transverse section showing the organization of body wall and cavity. 1. Dorsal blood vessel. 2. Circular muscles. 3. Longitudinal muscles. 4. Notopodium. 5. Neuropodium. 6. Ventral blood vessel 7. Ventral nerve cord. 8. Coelom. 9. Gut. 10. Oblique muscles. 11. Epidermis. 12. Cuticle. 13. Parietal peritoneum.

which lines the burrows. The epidermis is highly vascularized. The skin performs many functions such as protection, sensory and respiration.

Muscle layers: *Nereis* has a well developed musculature. It consists of three layers-i) circular ii) longitudinal and iii) oblique muscles. These are composed of unstriated muscle fibres.

The circular layer of muscles lie below the epidermis. The contraction of these muscles makes the body thin.

The longitudinal layer of muscles are arranged in four separate bundles. Two of them are dorsolateral. The other two are ventrolateral. Contraction of these muscles make the body thicker.

The oblique muscles are two pairs. These originate from the median ventral line. The muscles run dorsolaterally. These are inserted into the circular muscles at the base of the parapodium. These muscles retract the parapodium.

Peritoneum: It is the inner most layer of the body wall. It is also known as somatic or parietal coelomic epithelium.

13.5 COELOM

The body cavity of *Nereis* is a true coelom. The coelom is schizocoelic. It is formed by the splitting of the mesoderm into two layers. It forms a spacious cavity called the perivisceral cavity. This space lies in between the body wall and the alimentary canal. The cavity is divided into compartments by transverse partitions called septa. The coelom of each segment is further divided into right and left compartments by the dorsal and ventral mesenteries. The septa are perforated, so that the compartments communicate with one another. The coelom is filled with colourless coelomic fluid. The fluid contains amoeboid corpuscles or coelomocytes. During breeding seasons it also contains reproductive cells in various stages of development. The coelom communicates with the out side by nephridia and coelomoducts. The coelomic body gives turgidity to the body. It thus acts as hydraulic skeleton and helps in locomotion also.

13.6 LOCOMOTION

Locomotion in *Nereis* is brought about by parapodia and longitudinal muscles. Parapodial movement effects slow crawling or creeping movements. In the other movement both parapodia and longitudinal muscles are active. The longitudinal muscles of right and left side contract alternately. This causes lateral wave-like movements of the body. These contractions are followed by the strokes of parapodia. This results in fast crawling or creeping movements or swimming rapidly.

13.7 DIGESTIVE SYSTEM

The alimentary canal of *Nereis* is a straight tube (Fig. 13.4). It extends from the anterior end to the posterior end. It is suspended in the body cavity by the dorsal mesentery and septa. It opens by the mouth at the anterior end and terminates by the anus at the posterior end. The alimentary canal is distinguished into three distinct regions - i) foregut or stomodaeum consists of buccal cavity and pharynx, ii) midgut or mesenteron of oesophagus and stomach intestine and iii) hindgut or proctodaeum of rectum. The foregut and the hindgut are lined by ectoderm and cuticle. The midgut is lined by endoderm.

The mouth is transverse slit. It opens ventrally below the prostomium. It is bordered laterally and ventrally by the peristomium. The mouth leads into the buccal cavity. It is a wide chamber located in the peristomium. The buccal cavity leads into a muscular, protrusible pharynx. It extends up to the fourth segment. These two chambers are lined by the ectodermal epithelium. The epithelium is continuous with the epidermis of the head. It is also lined by a thick cuticle. The cuticle is

thickened at places to form denticles or paragaths or teeth. The posterior part of the pharynx has a thick muscular wall and a narrow lumen (Fig. 14.5. A and B). A pair of stout dark, chitinous jaws are present on the lateral walls. The inner margins of the jaws are serrated. The pharyngeal wall are connected by protractor and retractor muscles. At the time of food capture the buccal cavity and the pharynx are fully everted. It forms the proboscis.

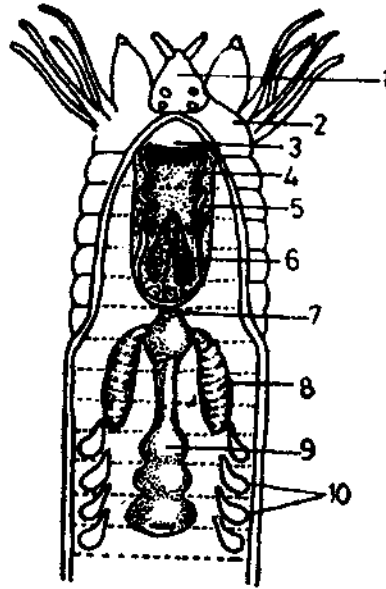

Fig. 13.4 *Nereis* - Digestive system. 1. Prostomium. 2. Peristomium. 3. Mouth. 4. Buccal cavity. 5. Pharynx. 6. Jaws. 7. Oesophagus. 8. Oesophageal gland. 9. Stomach - intestine. 10. Nephridia.

The pharynx leads into a narrow tube, the oesophagus. It occupies five segments. A pair of large oesophageal caecae open into the oesophagus that are believed to secrete proteolytic enzymes. The oesophagus opens into the stomach-intestine. This opening is guarded by a sphincter.

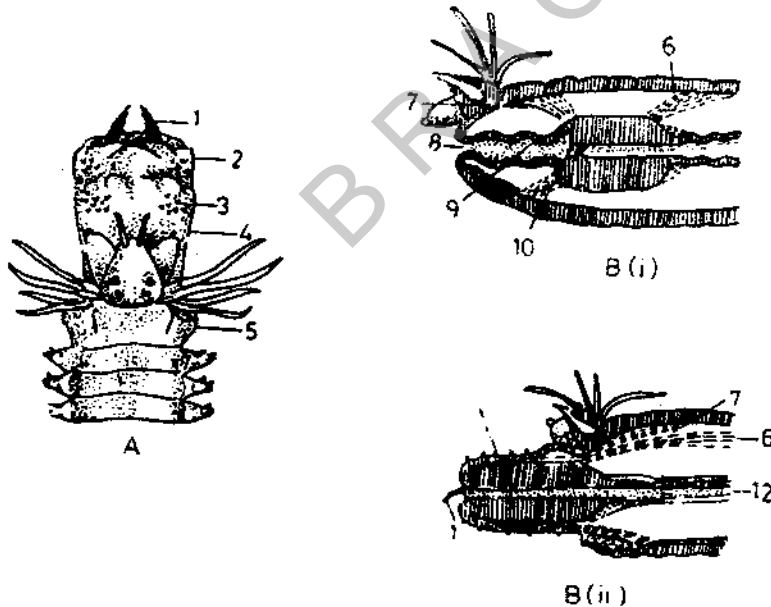

Fig. 13.5 *Nereis*. A. Everted pharynx exposing the jaws and denticles. B. Diagrammatic representation of pharynx (i. When retracted; ii. When everted). 1. Jaw. 2. Pharynx everted. 3. Denticles. 4. Everted buccal region 5. Peristomium. 6. Retractor muscles. 7. Protractor muscles. 8. Mouth. 9. Buccal cavity 10. Pharynx with jaws. 11. Oesophagus.

The stomach-intestine is a wide tube. It extends through the remaining length of the animal. It is the principle site of digestion and absorption. It continues into the rectum. Rectum is a short tube. It opens outside through the anus located in the pygidium.

Food capture: *Nereis* is a **carnivorous** animal. It feeds on small animals such as crustaceans, small molluscs, larvae and other worms etc. Usually the prey is captured with the help of jaws. The pharynx is everted by the pressure of coelomic fluid and contraction of protractor muscles. Retraction is effected by the retractor muscles. The prey is held in between the jaws when the pharynx retracts. This type of feeding is known as **raptorial feeding**.

Nereis also feeds by another method. It lives in U-shaped burrows. It secretes a cone of mucus in front of the mouth. In this the micro-organism gets entangled. A current of water is created by the parapodia. The mucus cone along with the trapped particles of food are directed towards the mouth. This method of feeding is known as **filter feeding**.

Physiology of Digestion: The ingested food is thoroughly masticated in the buccopharyngeal region. Digestion is effected by the digestive juices secreted by the oesophageal glands and the gland cells of the stomach-intestine. Digestion is extracellular. The stomach-intestine absorbs the digested food. The undigested food passes on to the rectum. It is thrown out through the anus.

13.8 RESPIRATION

Gills and branchial filaments present in other polychaetes are absent in *Nereis*. The general body surface and the parapodia serve the function of respiration. These are profusely supplied with blood vessels. Gas exchange takes place at the surface of these organs.

13.9 BLOOD — VASCULAR SYSTEM

Nereis has a well developed blood vascular system. It consists of a fluid tissue called, the blood. It circulates throughout the body in closed blood vessels. Therefore the circulatory system is known as the **closed type**.

The blood of *Nereis* consists of plasma and corpuscles. The blood is red in colour. The red colour of the blood is due to the presence of respiratory pigment known as **chlorocruorin** or **erythrocrucorin** in the plasma.

The blood vessels are two types. These are a distributing vessel and a collecting vessel. The two vessels communicate with one another by capillaries. In *Nereis* there are two main blood vessels—a median dorsal blood vessel and a median ventral blood vessel (Fig. 13.6).

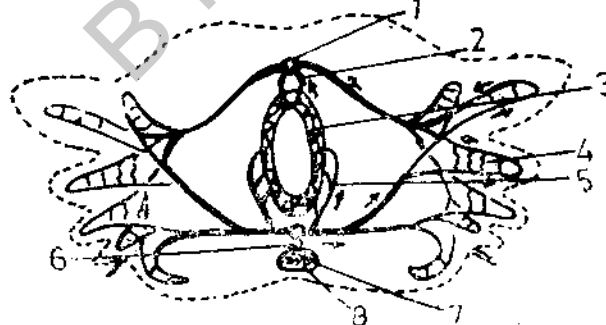

Fig. 13.6 *Nereis* - T.S. Showing blood vascular system. 1. Dorsal blood vessel. 2. Dorso-intestinal vessel. 3. Alimentary canal. 4. Blood vessel to parapodia. 5. Ventro-intestinal vessel. 6. Ventral blood vessel. 7. Ventral nerve cord. 8. Perineural vessel.

Dorsal blood vessel lies in the mesentery above the alimentary canal. It extends throughout the length of the body. It is highly contractile. Blood flows from behind forwards in this vessel. It forms a capillary net-work in the region of oesophagus. It joins with the ventral blood vessel in the fifth segment. It is a collecting blood vessel. It collects blood from the stomach-intestine by two dorso-intestinal vessels. It also collects blood from body wall, parapodia and nephridia. In the oesophageal region it acts like a distributing vessel.

Ventral blood vessel is mainly a distributing vessel. It runs almost the entire length of the body below the alimentary canal. It is non-contractile. Blood flows in it from anterior to posterior end. It

is a distributing vessel. It distributes blood to stomach-intestine, to the body wall, parapodia and to lateral vessels. In the anterior end it acts as a collecting vessel. It collects blood from the oesophagus. Posteriorly it joins the dorsal vessel by circumrectal ring in the anal segment.

The dorsal and ventral vessels are connected in each segment by a pair of loop-like transverse vessels or lateral vessels. These are known as lateral commissural vessels. Each of these vessels divides into afferent branches. These branches carry or distribute blood to the body wall, nephridium and parapodium of that side. Here these vessels break up into capillaries. Blood is collected from these organs by efferent branches. The efferent branches unite and open into the dorsal blood vessel.

A thin sub-neural vessel runs below the ventral nerve cord. Blood flows in it from anterior to posterior end. It collects blood from the lower body wall. It joins the ventral blood vessel.

13.10 EXCRETORY SYSTEM

Excretion in *Nereis* is carried on by *nephridia*. These are coiled tubules. These are a pair in each segment. Nephridia are absent in the peristomium and pygidium. Each nephridium consists of the following parts - nephrostome, neck, body and nephridiopore. The body and neck are enclosed in a syncytial mass of protoplasm.

Each nephridium opens into the coelom by a ciliated funnel called the *nephrostome*. It opens to the exterior by the *nephridiopore*. This opening is present at the base of the parapodium near the ventral cirrus.

The main body is an irregular, oval and compact gland-like mass. It lies transversely in the segment. It contains a highly convoluted and mostly ciliated tubule (Fig. 14.7. A). The nephrostome lies in the anterior segment. This type of open nephridium is known as *metanephridium*.

Nephridia collect wastes from coelomic fluid and blood by diffusion. The coelomocytes with the waste enter the ciliated nephrostome. They are pushed out through the nephridiopore by the ciliary action. The chief nitrogenous waste excreted by *Nereis* is ammonia.

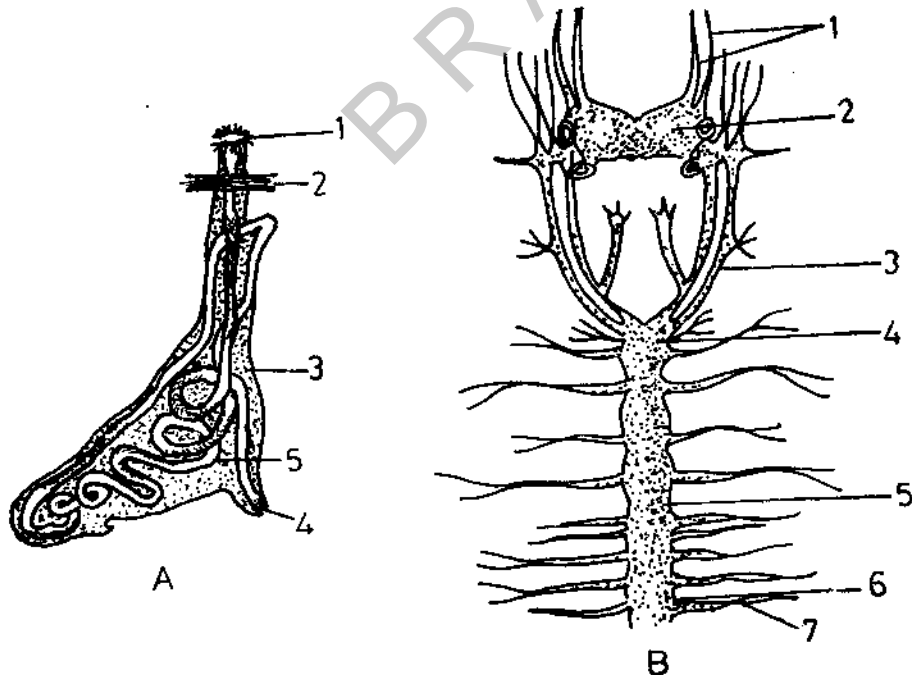

Fig. 13.7 *Nereis*. A. Nephridium. 1. Nephrostome. 2. Septum. 3. Protoplasmic matrix. 4. Nephridiopore. 5. Coiled portion of the tubule. B. Nervous system. 1. Nerves to palps. 2. Suprapharyngeal ganglia or brain. 3. Circumpharyngeal connectives. 4. Subpharyngeal ganglion. 5. Ventral nerve cord. 6. Segmental ganglia. 7. Nerve fibres.

13.11 NERVOUS SYSTEM

The nervous system of *Nereis* is well developed. It is metameric in its arrangement. It consists of central, peripheral and visceral nervous systems.

Central nervous system: It consists of brain or cerebral ganglia or suprapharyngeal ganglia. It is a large, bilobed mass located dorsally in the prostomium. A pair of stout circumpharyngeal connectives arise from the brain (Fig. 13.7. B). Each one of the connectives encircles the pharynx and meets below in third segment. It forms a nerve ring. A sub-pharyngeal ganglia is formed here. The ventral nerve cord continues from the sub-pharyngeal ganglion. It runs along the entire length of the animal. It is actually formed by the fusion of two very closely held cords. These lie in a common sheath of connective tissue. The nerve cord has a double ganglion in each segment beginning from the fourth segment onwards.

The peripheral nervous system consists of nerves arising from the brain and the nerve cord. These supply to different parts of the body. Nerves are distributed to eyes, tentacles and palps. The peristomial cirri are innervated by nerves arising from the ganglion located on the circumpharyngeal connectives. Three pairs of nerves arise from each ganglion of the nerve cord. These innervate the organs of the segment, parapodia and body wall.

The visceral nervous system consists of a net-work of thin nerves and a few ganglia. These supply nerves to dorsal and ventral wall of the pharynx. These are involved in the motor control of the proboscis.

Sense organs: In *Nereis* the sense organs are specialised and well developed. Prostomial tentacles, prostomial palpi and peristomial cirri in the head region are tactile sense organs. They are sensitive to touch.

Nuchal organs, a pair of pits on the prostomium are believed to be chemoreceptory.

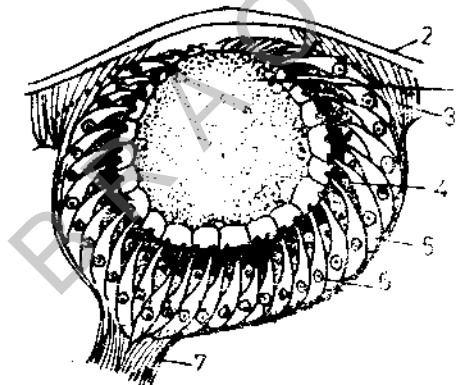

Fig. 13.8 *Nereis* - Ventral section of an eye. 1. Lens. 2. Cuticle. 3. Epidermis. 4. Pigment. 5. Retina. 6. Nucleus 7. Optic nerve.

Eyes are photoreceptors. There are four simple eyes. Each eye has a cup-like structure (Fig 13.8). It is made up of pigmented retinal cells. The cells are rods-like. The opening of the cup is the pupil. The external cuticle forms a transparent cornea. There is a transparent, gelatinous refractive lense inside the cup. The retinal cells are joined to nerve fibres of the optic nerve. The eyes are photoreceptive.

13.12 REPRODUCTIVE SYSTEM

Nereis is dioecious. Gonads occur only during the breeding season. These develop from the ventral coelomic epithelium. In the males the testis is one pair lying between the nineteenth and twenty fifth segments. It may be limited to only one segment. But in a few other species the testis may extend to more number of segments.

In the female the ovaries lie in many segments around the blood vessels. Genital ducts are absent in both male and female. The reproductive cells are released into the coelom. These cells mature in the coelom itself. Mature gametes are discharged to the exterior by rupture of the body wall. In some nereids the female dies after discharging the mature reproductive cells. Fertilization occurs externally in sea water.

13.12.1 Development

The egg is **telolcithal**. The cleavage is **spiral and determinate**. The egg after a series of cleavages forms the blastula and later the gastrula. The gastrula develops into a **trochophore** or **trochosphere larva** (Fig. 13.9).

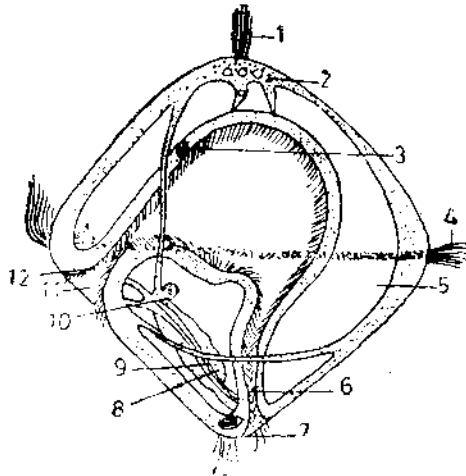

Fig. 13.9. *Nereis-Trochophore larva*. 1. Apical tuft of cilia. 2. Apical sensory plate. 3. Eye spot. 4. Prototroch. 5. Blastocoel. 6. Proctodaeum. 7. Anus. 8. Mesodermal band. 9. Larval nephridium. 10. Statocyst. 11. Mouth. 12. Stomodaeum.

The trochophore is pear-shaped. It has a thin external ectodermal epithelium. It forms thickening at the two ends. The upper end is known as the apical region. The thickening is called **apical plate**. It has a tuft. There is an alimentary canal. The mouth opening leads into the oesophagus. It is lined by the ectoderm. The stomach is endodermal in origin. The hindgut is formed from the ectoderm. It opens outside by the anus. A preoral ciliary band is present on the equatorial ring. It is known as **prototroch**. It helps the larva to lead a free swimming life. An eye spot is present below the apical plate.

The trochophore is pelagic. It drifts about in the sea by its prototroch. The trochophore undergoes metamorphosis. The apical organ forms the prostomium with brain, tentacles and eyes. The part immediately behind forms the peristomium. The larva grows from the anal end. New segments are added by metameric segmentation. Thus adult form is reached.

13.12.2 Heteronereis

A few nereid worms occur in two different forms or phases. At sexual maturity these forms exhibit anatomical differentiation in the posterior half of the body. It is known as **epitoke**. The anterior segments do not show any change. This region is called **asexual region** or **atoke**. The sexually mature form with these two regions is known as **Heteronereis**.

Check Your Progress

1. The most distinguishing feature of a polychaete is the presence of _____
2. In spite of a well-developed straight alimentary canal the mode of intake in *Nereis* is _____
3. Epitokal modifications signify the manifestation of secondary sexual characters in *Nereis*. Such a phase consisting of atoke & epitoke is known as _____

13.13 SUMMARY

Nereis (*Neanthes*) is the common sand or clam found in marine water. It is a typical annelidan

exhibiting segmentation. The head bears a pair of prostomial tentacles, two pairs of a peristomial cirri and two pairs of a simple eyes. Parapodia, the paired lateral outgrowths in each segment are the locomotor organs. Body wall is dermomuscular. Body cavity, a true coelom lined on either side by coelomic epithelia. Alimentary canal well differentiated into regions with a pair of oesophageal glands. Respiration by skin and parapodia. Closed type of blood vascular system. Blood is red in colour due to the presence of erythrocurin. Excretion by specialised excretory organs known as nephridia, a pair in each segment. Nervous system with a brain, nerve ring and ventral nerve cord. Sense organs are eyes, tentacles, cirri etc., which are receptors of different types. These are dioecious. The gonads are formed only during the breeding season. Heteronereis is the reproductive phase. Development is indirect. Trochophore or trochosphere is the characteristic larva.

13.14 CHECK YOUR PROGRESS — MODEL ANSWERS

1. Parapodia
2. Filter feeding
3. Heteronereis

13.15 MODEL EXAMINATION QUESTIONS

I. Answer the following in about 30 lines.

1. Describe the external characters of *Nereis*.
2. Give brief account of the digestive system feeding mechanism and physiology of digestion of *Nereis*.
3. Describe the blood vascular system of *Nereis*.
4. Describe briefly the reproductive system and process of development in *Nereis*.

II. Answer the following in about 10 lines

1. Give an account of excretory system of *Nereis*.
2. Describe the nervous system of *Nereis*.
3. Describe the trochophore larva with the help of a neat labelled diagram.
4. Describe the structure of body wall in *Nereis*.

13.16 GLOSSARY

Biramous	: Having two branches
Botryoidal tissue	: It is a pigmented mass of connective tissue. It occupies most of the coelom. It restricts the coelom to a few channels of the haemocoelomic canals.
Chlorogogen cells	: These are yellow cells formed by the inner coelomic epithelium. These collect waste material from the blood supplied to the intestine. The cells then are known as eleocytes. These drop into the coelomic fluid. Nephrostomes collect these and send them out. These are compared to the liver of vertebrates because of its many functions.
Clitellum	: It is formed as a thickening around a few segments in earthworms and leeches. After copulation and sperm exchange it secretes a cocoon.
Cocoon	: It is a bag-like structure secreted by the cells of the clitellum. Spermatozoa and eggs and albumen are discharged into this structure. Development of the fertilized eggs takes place within this cocoon.
Copulation	: A sexual act for the transference of sperm from one to another of mating partners.
Hermaphrodite	: Animals having both male and female reproductive organs.
Metamerism	: The body of annelids is divided into ring-like structures called

- segments or metmeres. Many of the organs are repeated in a linear series.
- Nephridia : These are highly coiled tubules which are excretory in function. These are arranged segmentally.
 - Nephridiopore : It is the external opening of the nephridium. It opens on the surface of the animals. It discharges the excretory wastes to the exterior.
 - Parapodia : These are lateral, hollow, biramous appendages of a few polychaetes. These are highly vascular. These are useful in locomotion and respiration.
 - Schizocoel : Coelom formed by the splitting of mesoderm. The outer layer lying towards the body wall is known as parietal or somatic mesoderm. The inner layer lining the alimentary canal is known as splanchnic or visceral mesoderm.

BRAOU

UNIT - 14 MOLLUSCA - GENERAL CHARACTERS AND CLASSIFICATION

Contents

- 14.1 Objectives
- 14.2 Introduction
- 14.3 General characters
- 14.4 Classification
 - 14.4.1 Class - monoplacophora
 - 14.4.2 Class - Amphineura
 - 14.4.3 Class - Scaphopoda
 - 14.4.4 Class - Gastropoda
 - 14.4.5 Class - Bivalvia
 - 14.4.6 Class - Cephalopoda
- 14.5 Summary
- 14.6 Check Your Progress — Model Answers
- 14.7 Model examination Questions

14.1 OBJECTIVES

In this unit the general characters of various groups of mollusca are discussed, which enable you to explain the salient features of these shallow heterogenous group which is built on the same fundamental plan.

14.2 INTRODUCTION

The term Mollusca was first introduced by Aristotle. Later in 1883 Lankester confirmed the name to the phylum. These soft bodied animals (mollis : soft) form the second largest phylum of invertebrates. Nearly 100,000 living species have been described and about 35,000 fossil species were recognised. Molluscs are mostly marine, though some are found in freshwater and on land. The phylum includes animals like snails, mussels oysters, cuttlefish, squids, pearly Nautilus etc.

14.3 GENERAL CHARACTERS

1. The body is unsegmented and bilaterally symmetrical. In some molluscs such as gastropods, bilateral symmetry is secondarily lost, so they become a symmetrical.
2. The body of a mollusc is soft and usually enclosed in a shell.
3. The body is enveloped by a loose, fleshy lobe called the mantle. The space between the mantle and the body is known as mantle cavity. The mantle lobe is attached to the rim of the shell.
4. The shell is secreted by the mantle. The shell may be external or internal. rarely absent. The shell protects the animal. It is made up of calcium carbonate and conchiolin.
5. The body can be divided into head, foot and visceral mass. Head is distinct bearing mouth and provided with tentacles and eyes.
6. In a few animals ventral body wall is modified into a muscular, flat or wedge-shaped foot. It is sometimes variously modified for creeping, burrowing and swimming.
7. Visceral mass contains the important organs such as digestive, excretory and reproductive organs.
8. Body cavity is a haemocoel. The true coelom is reduced and restricted to the pericardial cavity, renal organs and reproductive organs.

9. The digestive system is complete with salivary glands and digestive gland. In many forms a rasping organ is present in the buccal cavity.
10. Respiration is effected by respiratory organs such as gills or ctenidia or the pulmonary sac. Sometimes even the mantle fold and the epidermis subserve the respiratory function.
11. The circulatory system consists of a dorsal heart with 1 or 2 auricles and a ventricle located in a pericardial cavity.
12. Excretion takes place in the kidneys, also called nephridia. These open into the pericardial cavity and from there to the exterior through nephridiopores.
13. Nervous system consists of paired cerebral, pleural pedal and visceral ganglia joined by commissures and connectives.
14. Sense organs are well developed. Eyes, tentacles, osphradium are a few of the sensory structures.
15. Sexes are usually separate (dioecious), some being hermaphrodites. Fertilization is internal or external.
16. Molluscs are mostly oviparous, a few are viviparous. Development is direct or indirect. When indirect metamorphosis takes place there are different types of larval stages called trochophore, veiger and glochidium.

14.4 CLASSIFICATION

The phylum is divided into the following six classes. The classification followed here is that of Morton and Yonge (1964) with certain modifications from Marshall and Williams (1977).

14.4.1 Class: Monoplacophora

(Gr. Monos: one; plax: plate; phorin: bearing)

These are bilaterally symmetrical marine molluscs which are segmented.

As the name of the class indicates, these are animals with a single shell which is dome-shaped.

Foot broad and flat with eight pairs of pedal retractor muscles.

Mantle encircles the body as a circular fold of the body wall.

A radula is present in the radular sac in the buccal cavity. The intestine is much coiled.

Five pairs of gills are present. They are located in the mantle groove.

Six pairs of serially arranged nephridia are located in the pallial groove.

Heart consists of two pairs of auricles and two ventricles.

Sexes are separate. 2 pairs of gonads are located in the middle of the body.

Example *Neopalina galathea* (Fig. 14.1 A)

14.4.2 Class: Amphineura

(Gr. Amphi : both; neuron: nerve)

These are flat or dorso-ventrally flattened molluscs. In some the body is flat and elongated.

Head is poorly developed

The foot is broad and flat or not prominent.

Mantle is extensive and provided with a dorsal shell composed of eight serially arranged plates. In some the shell is absent.

Radula is present in the buccal cavity.

Sexes separate. Development indirect with a larval stage of the trochophore type.

Examples: *Chiton* (Coat of mail shell,) (Fig. 14.1 B). Serially arranged shells eight in number are present.

Chaetoderma (Fig. 14.1 C) — Body worm like Head, mantle, foot and nephridia are absent. Body covered with cuticle beset with numerous calcareous spicules.

14.4.3 Class: Scaphopoda

(Scaphos: tusk)

The class Scaphopoda contains about 200 sps. of burrowing, marine molluscs. These are popularly known as **tusk or tooth shells**.

The shell is elongated tube in the shape of an elephant, tusk or trumpet. The shell is open at both the ends.

Mantle is tubular completely enclosing the body.

Foot is reduced for digging.

There are no specific respiratory organs - mantle folds form furrows and are ciliated. These help in gas exchange.

Circulatory system is poorly developed. Pericardium is absent.

Renal organs are paired.

Scaphopods are dioecious, i.e., sexes are separate.

Development indirect. A free swimming trochophore develops into veliger. This metamorphoses into the adult.

Example: *Dentalium* (Elephant tusk shell) (Fig. 14.1. D)

14.4.4 Class Gastropoda

The class includes molluscs like snails, slugs, limpets etc.

The class Gastropoda is the largest group of Mollusca. Nearly 40,000 living species have been described. In addition over 15,000 species of fossil forms were discovered.

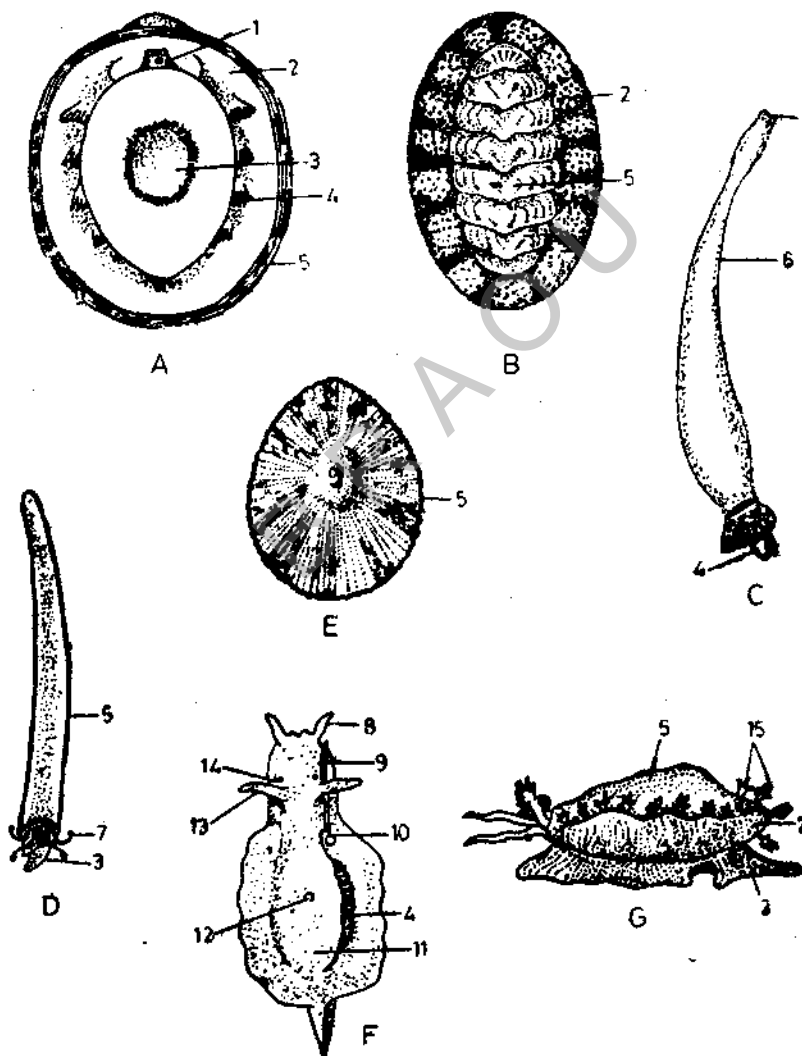

Fig. 14.1 Some Molluscs. A. *Neopalina*. B. *Chiton*. C. *Chaetoderma*. D. *Dentalium*. E. *Patella*. F. *Aplysia*. G. *Cypraea*. 1. Mouth. 2. Mantle. 3. Foot. 4. Gills. 5. Shell. 6. Body. 7. Capitulum. 8. Tentacle. 9. Penis. 10. Common genital opening. 11. Visceral lump. 12. Opening of the shell sac. 13. Rhinophore. 14. Eye. 15. Mantle tentacles.

These have a varied distribution. Most of the gastropods are marine, a few are freshwater forms and some others terrestrial. Gastropods like snail are amphibious.

The typical gastropod shell is single, spirally coiled. The univalve shells are variously shaped.

Body unsegmented, asymmetrical due to a biological phenomenon called torsion.

Visceral mass is also coiled.

Foot is ventral, broad and muscular forming a creeping sole. An operculum is present on the dorsal surface of the foot to form a lid for the mouth of the shell. The head and foot are withdrawn into the shell.

Mantle cavity variously modified depending on the shapes of the shell. Mantle cavity encloses within it a number of organs which are collectively known as **pallial complex**.

Buccal cavity contains an **odontophore** with a **radula** bearing rows of chitinous teeth.

Digestive system is characteristic in having a long, coiled intestine. The rectum is parallel to the intestine. Anus opens outside anteriorly a little right of the mouth.

Respiration is performed by gills or **ctenidia**. Amphibious gastropods have pulmonary sacs in addition to the gills.

Circulatory system is open and the heart is enclosed in a pericardium. **Haemocyanin** pigment is present in blood.

Excretion is by renal chambers.

Nervous system comprises a distinct cerebral and pleural ganglia. Buccal, pedal and visceral ganglia are also present. Commissures and connectives join different ganglia.

Sense organs are well developed. Eyes are usually located on stalks. **Statocysts** are organs of equilibrium. **Osphradium** is chemoreceptor organ to test the purity of water in freshwater forms.

Sexes are separate (dioecious) in most of the forms. A few are hermaphrodites.

Development is indirect. Larval stages include trochophore and veliger. Veliger is said to be a modified form of trochophore.

Some gastropods of the freshwater tide over unfavourable conditions by undergoing aestivation. These burrow themselves in the earth and go through summer sleep.

Examples: *Pila* (Apple snail pond snail) (Fig. 14.1), *Patella* (Fig. 14.1 E) *Aplysia* (Fig. 14.1F), *Cypraea* (Fig. 14.1 G). etc.,

14.4.5 Class : Bivalvia

Class Bivalvia is also known as **Pelecypoda** and **Lamellibranchiata**.

It is the second largest class of Mollusca. It includes animals like clams, mussels, oysters etc., which are of great economic importance.

They are bilaterally symmetrical, laterally compressed with two lateral valves.

The valves are hinged dorsally and free ventrally.

The mantle is extensive, lateral, bilobed corresponding with the two valves.

Head is rudimentary. Pharynx, jaws, radula and tentacles are absent.

Foot is ventral, muscular wedge shaped or plough-share. It is adapted for burrowing. In sedentary forms foot is absent. The majority of species are marine and burrow in sand and mud. Some bore into rocks and wood. Some are fixed to rocks by cement or byssus threads. A few can swim.

Coelom is reduced to a dorsally placed pericardium.

Alimentary canal is coiled with large paired digestive glands.

Gills or ctenidia are leaflike, hence the name Lamellibranchiata.

Heart is enclosed within the pericardium. It consists of a median ventricle and two auricles.

Excretory organs are paired nephridia or kidney also known as organ of Bojanus. In some Keber's organ or pericardial gland also functions as excretory organ.

Nervous system consists typically of four pairs of ganglia-cerebral, pleural, pedal and visceral. Cerebral and pleural ganglia of each side usually fuse into a single cerebro-pleural ganglia.

Sense organs are statocysts and osphradia. Eyes are absent.

Sexes mostly separate (dioecious), rarely united *Poromya*

Development is accompanied by metamorphosis. Larval stages are trochophore or glochidium. **Glochidium** leads an ectoparasitic life for a brief period before metamorphosing into the adult form.

Examples: Lamellidens or Unio-Fresh water mussel (Fig. 14.2 A).

- Mytilus* - Sea mussel (Fig. 14.2 B)
Ostrea - Edible oyster (Fig. 14.2 C)
Pinctada - Pearl oyster (Fig. 14.2 D)
Pecten - Scallop (Fig. 14.2 E)
Teredo - Ship worms (Fig. 14.2 F)
Solen - Razor clam or razor shell (Fig. 14.2 G)

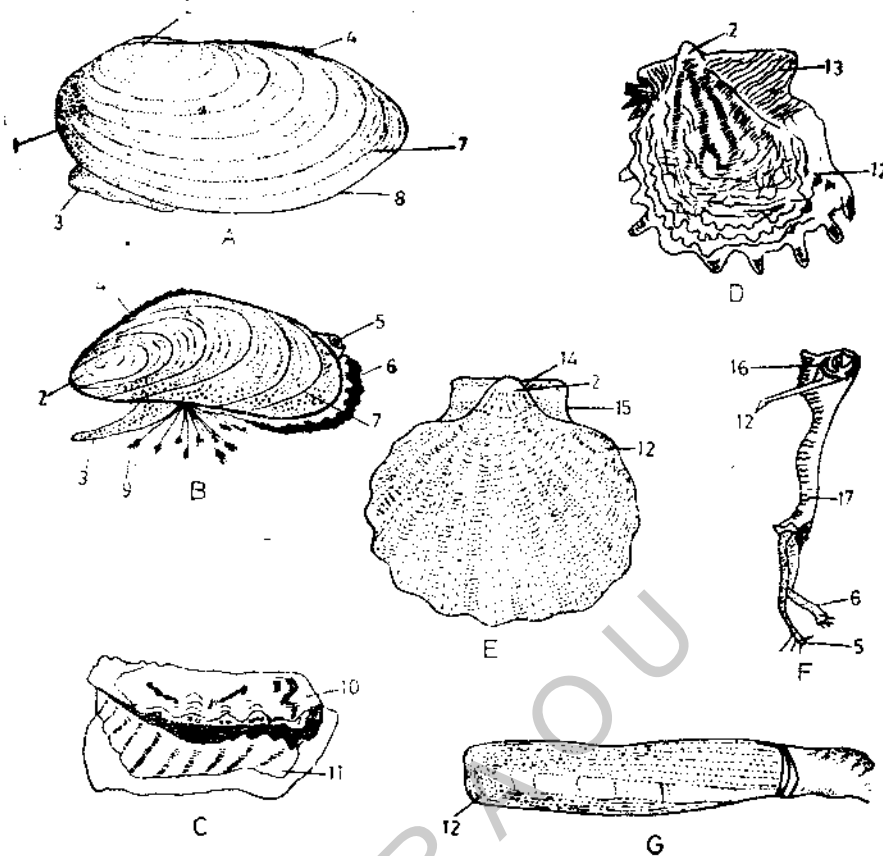

Fig. 14.2 Some Molluscs. A. Lamellidens. B. Mytilus. C. Ostrea. D. Pinctada. E. Pecten. F. Teredo. G. Solen. 1. Shell. 2. Umbo. 3. Foot. 4. Hinge ligament. 5. Exhalant siphon. 6. Inhalant siphon. 7. Lines of growth. 8. Shell margin. 9. Byssus threads. 10. Movable right valve. 11. Left valve (permanently fixed to rocks). 12. Shell valve. 13. Ear-shaped process. 14. Hinge. 15. Wing. 16. Dorsal mantle fold. 17. Body.

14.4.6 Class: Cephalopoda

The class Cephalopoda contains the nautili, cuttle fish, squids and octopods.

These are the most specialized and highly organized molluscs.

These are exclusively marine.

The head is well developed. It bears a pair of highly developed eyes and a number of arms or tentacles.

The foot is modified into a **siphon**. This siphon is associated with a large mantle cavity. The siphon and mantle cavity assist in swimming activity of the cephalopods.

A completely developed shell is observed only in Nautilus and a few extinct representatives of the class. In squids and cuttle fish the shell is reduced and internal.

Mouth bears jaws and radula.

Two or four pairs of bipectinate gills are present.

Circulatory system includes heart with two or four auricles, a transversely placed ventricle, blood vessels and haemocoelomic spaces.

Renal organs are four in number. They are contained in the pericardial cavity. They do not communicate with it.

Nervous system is highly developed. The principal ganglia are concentrated around the oesophagus.

Eyes are very well developed and prominent. They superficially resemble the vertebrate eye. Statocysts are organs of balance. A pair of osphradia are present. Bioluminescence is common in many deep sea cephalopods.

Sexs are separate (dioecious). Sexual dimorphism exists in a few cephalopods. One of the arms is hectocotyised in males. This helps in sperm transfer.

Development direct without metamorphosis. In some cephalopods ink glands are present. These help to produce a smokey screen to escape from enemies.

Marshall and Williams suggest that the old concept of arms and tentacles representing a modified anterior region of the foot is probably erroneous. They are of the opinion that the arms and tentacles are true cephalic structures. They believe the name cephalopoda may thus be a misnomer.

Examples: *Sepia* (cuttlefish) Shell internal (Fig. 14.3 A) *Loligo* (squid) (Fig. 14.3)

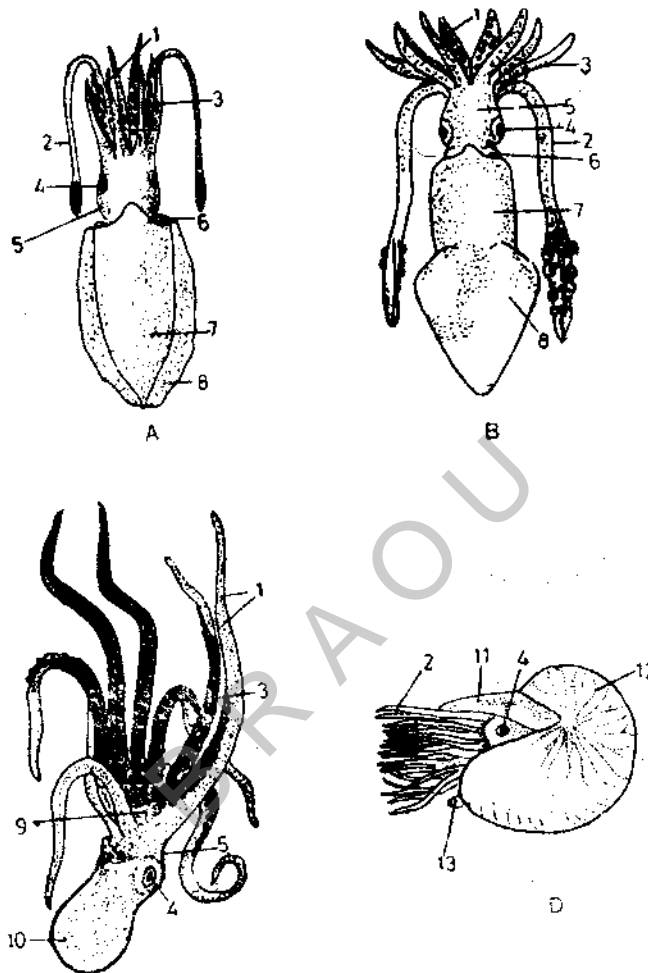

Fig. 14.3 Some Molluscs. A. *Sepia*. B. *Loligo*. C. *Octopus*. D. *Nautilus*. 1. Oral arms. 2. Tentacle. 3. Suckers. 4. Eye. 5. Head. 6. Collar. 7. Trunk. 8. Lateral fin. 9. Web. 10. Visceral lump. 11. Hood. 12. Shell. 13. Funnel.

- Architeuthis* Giant squid measuring nearly 16 m in length. The body alone is 6 mts. long The tentacles are about 10 mts. in length.
- Octopus* Devil fish, body globose with large trunk and eight arms. The arms are webbed at the base. (Fig. 14.3 C)
- Argonauta* Paper nautilus. Exhibits remarkable sexual dimorphism. Male is small about 2.5 cm. Female is large about 20 cm. Shell thin and transparent.
- Nautilus* Commonly called pearly nautilus. Shell is spirally coiled and many chambered. The animal occupies the outermost chamber

Check Your Progress

1. The twisting of visceral mass leading to torsion is a distinctive character of class.....
2. In the head is greatly reduced in size.....
3. Internal shell is found in cuttle fishes which belong to the class.....

14.5 SUMMARY

General characters of the phylum as a whole is described. The Phylum is divided into six classes. Neopalina a living fossil is included in the class monoplacophora. Scaphopoda are tusk shelled animals. Gastropoda includes univalves with spirally coiled shells where the animals have secondarily lost the symmetry. Bivalvia are laterally compressed animals with two lateral valves. Cephalopoda most advanced of all the other mollusce have elongated tentacle - like arms provided with suckers. Some of the large sized invertebrates are included in this phylum.

14.6 CHECK YOUR PROGRESS MODEL — ANSWERS

1. Gastropoda
2. Bivalves
3. Cephalopoda

14.7 MODEL EXAMINATION QUESTIONS

I. Answer the following in about 30 lines

1. Describe the general characters of phylum Mollusca.
2. Describe the general characters of the class Gastropoda. Give examples.
3. Describe the general characters of the class Bivalvia and compare with that of gastropoda.

II. Answer the following in about 10 lines

1. Into how many classes Mollusca is divided? What are they? Give examples.
2. Write about the class Monoplacophora.
3. Describe the general characters of the class Scaphopoda.

UNIT - 15 PILA GLOBOSA

Contents

- 15.1 Objectives
- 15.2 Introduction
- 15.3 External Characters
- 15.4 Structure of The Soft Parts of The Body
- 15.5 Digestive System
 - 15.5.1 Alimentary canal
 - 15.5.2 Digestive glands
- 15.6 Respiratory System
 - 15.6.1 Aquatic respiration
 - 15.6.2 Aerial respiration
- 15.7 Blood Vascular System
 - 15.7.1 Course of circulation
- 15.8 Excretory System
- 15.9 Nervous System
 - 15.9.1 Sense organs
- 15.10 Reproductive System
 - 15.10.1 Male reproductive system
 - 15.10.2 Female reproductive system
 - 15.10.3 Copulation and oviposition
- 15.11 Summary
- 15.12 Check Your Progress — Model Answers
- 15.13 Model Examination Questions

15.1 OBJECTIVES

In this lesson a detailed study of apple snail is made so as to enable the student to understand the organisation of Mollusca in general and class Gastropoda in particular.

At the end you will be in a position to explain that the molluscans taxonomically are the best known of all the larger groups of animals. Further gastropods have well organised systems to make them fit for amphibious life to complete the struggle for existence.

15.2 INTRODUCTION

Pila is a fresh water gastropod molluscan. It is found in ponds, pools, tanks, lakes, marshes, paddy fields etc. The common species found in India are *Pila globosa* and *P. virens*.

Systematic Position

Phylum	Mollusca
Class	Gastropoda
Sub-class	Prosobranchiata (Streptoneura)
Order	Pectinibranchiata (Monotocardia)
Genus	<i>Pila</i>
Species	<i>P. globosa</i>

Pila globosa is commonly known as apple snail. They occur in water masses where there is abundant aquatic vegetation like *Vallisneria*, *Pistia* etc., It feeds on these plants. *Pila* is adapted to lead an amphibious life. It creeps at 'snail's pace' with its ventral muscular foot.

15.3 EXTERNAL CHARACTERS

Shell: The body of *Pila* is enclosed in a globose shell. The shell is made up of single valve which is spirally coiled. The coiling is around a central axis, the **columella**. The top of the shell is known as the **apex**. It is the smallest and oldest whorl. A shell consists of 5 1/2 to 6 1/2 whorls. The whorl gradually increases in size. The lines between the whorl are called **sutures** (Fig. 15.1). The last whorl is known as the **body whorl**. It is the largest. It encloses most of the body. It has a large opening known as the **mouth or aperture**. From this opening the head and the foot of the living animal protrude out. The outer margin of the mouth is called the **outer lip** and the inner margin as **inner or columellar lip**. The columella, around which the whorls are coiled is hollow. Its opening to the exterior is known as **umbilicus**. The shell with umbilicus is known as **perforate or umbilicated**. The surface of the shell bears slightly raised ridges.

If the shell of *Pila* is held with the apex upwards and the aperture facing the observer, the aperture will be on the right and the shell coiled anti-clockwise from it. A shell of this type is called **dextral**, which normally occurs in most gastropods. If the aperture lies to the left and shell coiled clockwise, then we have a **sinistral shell**, which is very rare and abnormal. A recent discovery shows that this is a hereditary trait, which is transmitted from generation to generation, like eye colour or hair colour in humans. "**Right-handedness**" (dextral) in snail is dominant over "**left-handedness**" (sinistral).

When the animal withdraws into the shell the mouth of the shell is closed by a calcareous plate known as the **operculum**. It is attached to the dorsal part of the foot. The inner surface of the operculum has a distinct elliptic area for attachment for the opercular muscles known as **boss**. (Fig. 15. 1.B)

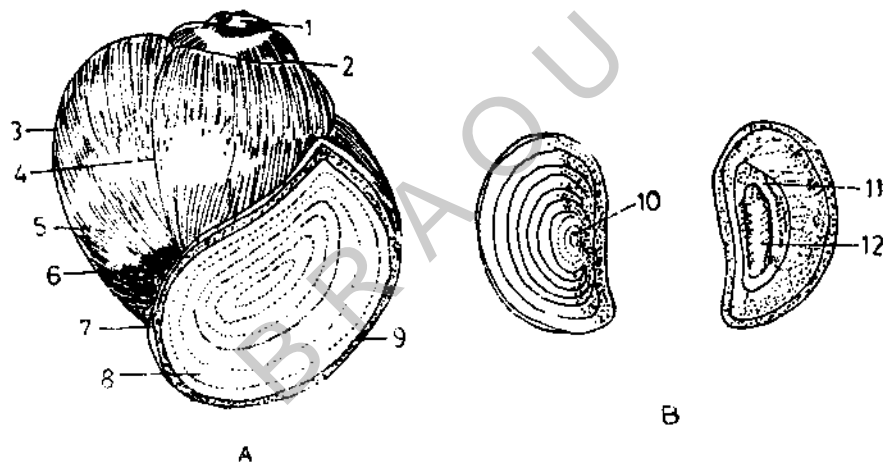

Fig. 15.1 *Pila globosa*, A. Shell. B. Operculum (outer and inner views) 1. Apex. 2. Suture. 3. Body whorl. 4. Varix. 5. Lines of growth. 6. Umbilicus. 7. Columellar lip. 8. Shell mouth. 9. Outer lip. 10. Nucleus 11. Shallow groove. 12. Boss.

Microscopic Structure of the Shell: The shell of *Pila* is made up of calcium carbonate and conchiolin. It consists of three layers. The outermost layer is known as **periostracum**. It is made up of a horny organic conchiolin. The middle layer is known as **ostracum**. It is made up of calcium carbonate. The innermost layer is called the **hyostracum** or **nacreous layer** of calcium carbonate. The conchiolin helps in holding the calcium carbonate.

15.4 STRUCTURE OF THE SOFT PARTS OF THE BODY

The body is divisible into three distinct regions the **head**, **foot** and **visceral mass**. When the animal is fully expanded the head and the foot lie outside the shell, but the visceral mass always remains enclosed in the shell. (Fig. 16.2).

Head: The head bears two pairs of **tentacles**. The first pair of tentacles or **labial palps** are small

and lie in front. The second pair lying behind them are long. The tentacles are hollow and contractile. A pair of eyes are present. They are borne on stalks called the ommatophores.

Foot: The large, strongly muscular ventral part of the body forms the foot. It is triangular in shape. It is used for creeping. Its dorsal posterior surface bears the operculum. When the foot is withdrawn the operculum close the mouth of the shell. Pedal mucous glands are located in the foot. Their secretions form a slime trail during locomotion.

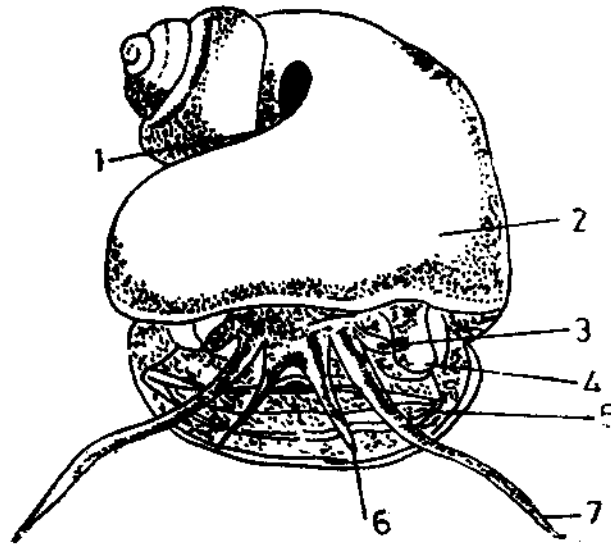

Fig. 15.2. *Pila globosa*. - soft parts of the body after the removal of the shell. 1. Visceral mass. 2. Mantle fold. 3. Eye on ommatophore. 4. Left nuchal lobe. 5. Foot. 6. First pair of tentacles. 7. Second pair of tentacles.

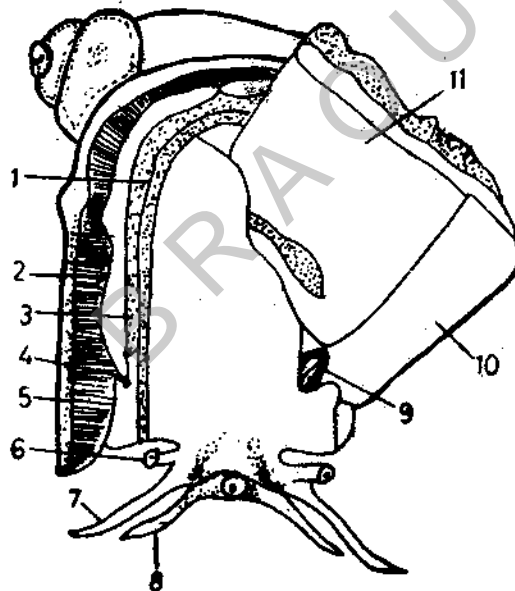

Fig. 15.3. *Pila globosa* - Pallial complex (female) 1. Epitaenia. 2. Rectum 3. Gonoduct 4. Anus. 5. Ctenidium. 6. Eye. 7. True tentacle. 8. Cephalic tentacle. 9. Osphradium. 10. Mantle. 11. Pulmonary sac.

Visceral mass: It contains all the main organs of the body. It fills all the whorls of the shell. It is spirally coiled like the shell. The visceral mass exhibits the phenomenon of torsion.

Mantle: The mantle covers the visceral mass. The edge of the mantle is thick. It contains shell glands which secrete the shell. The mantle has two fleshy lobes called nuchal lobes. The left one is much longer than the right and forms a respiratory siphon, during aerial respiration.

The mantle encloses a large space. This is known as the mantle cavity or pallial cavity. This cavity encloses within it a number of organs. These are collectively known as organs of the pallial

complex. (Fig. 15.3). There is a prominent ridge on the floor of the cavity. It is known as **epitaenia**. The epitaenia divides the cavity into two chambers - a right **branchial chamber** and a left **pulmonary chamber**. Ctenidium or gill, rectum, gonoduct, hypobranchial gland lie in the branchial chamber. The anterior chamber of the renal organ, the opening of the pulmonary chamber and the osphradium lie in the pulmonary chamber.

Coelom: The coelom is reduced and restricted to the cavities of pericardium, kidney and gonad. The visceral organs are surrounded by sinuses or spaces containing blood. These blood filled spaces form the **haemocoel**.

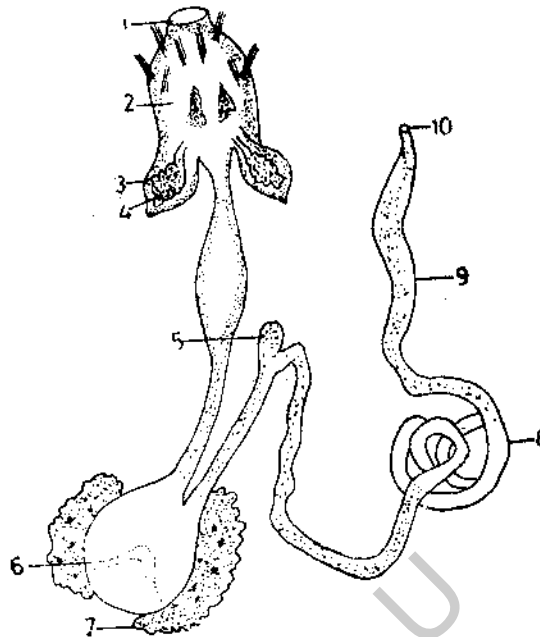

Fig. 15.4. *Pila globosa* - Digestive system. 1. Mouth. 2. Buccal mass. 3. Oesophageal pouch. 4. Salivary glands. 5. Caecum. 6. Stomach. 7. Digestive glands. 8. Intestine. 9. Rectum. 10. Anus.

15.5 DIGESTIVE SYSTEM

The digestive system of *Pila globosa* consists of (i) a **tubular alimentary canal** and (ii) **glands** associated with the system.

15.5.1 Alimentary canal

It consists of **foregut, midgut and hindgut**.

Foregut includes the mouth, buccal mass and oesophagus (Fig. 15.4). The mouth is a narrow vertical slit. It leads into the buccal mass. The buccal mass is a large cavity having thick walls with

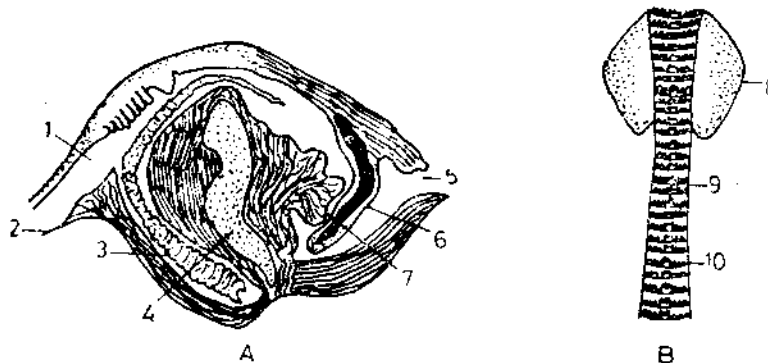

Fig. 15.5 *Pila globosa*. A. Ventral section of the buccal mass. B. Structure of radula. 1. Buccal cavity. 2. Oesophagus. 3. Radula. 4. Odontophore. 5. Mouth. 6. Jaw. 7. Subradular organ. 8. Flap. 9. Radular ribbon. 10. Transverse row of teeth.

several sets of muscles. The jaws hang from the roof of the buccal mass (Fig. 15.5 A). The jaws are provided with muscles. The cavity behind the jaws is very large. The floor of the buccal cavity has a large elevation called **odontophore**. **Radula**, the ribbon shaped structure lies on the elevated odontophore (Fig. 15.5 B). The radula bears numerous horny teeth arranged in transverse rows. The radula is continued behind into a sac known as the radular sac. The teeth are produced by the radular sac. Radula continues to increase in size and replaces the wornout teeth by pushing the radula forward.

The buccal mass leads into a narrow, long **oesophagus**. A pair of **salivary glands** are present at the sides of the buccal mass posteriorly. The glands open into the buccal cavity by ducts. There are two oesophageal pouches one on each side of the oesophagus. They serve for a temporary storage of food.

The **midgut** includes the stomach and intestine. The **stomach** lies on the left side of the visceral mass. It consists of two parts—a saccular **cardiac chamber** in continuation with the oesophagus and a tubular **pyloric chamber** which opens into the intestine. A **caecum** is connected with the pyloric chamber.

The intestine is a coiled tube lying in the visceral mass. It continues, into the rectum. The rectum is a thick-walled tube. It enters the mantle cavity and opens by the anus anteriorly on the right side of the mouth.

15.5.2 Digestive Glands

The **digestive gland** lies in the visceral mass. The gland is brownish or of dirty green colour. It consists of two lobes. One of the lobes is smaller. This small lobe is in contact with the stomach. The larger lobe extends into the apex of the spirally coiled shell. A large duct comes out of each lobe and the two tubes unite into a common duct. This common duct opens into the stomach.

The food of *Pila* consists of aquatic weeds which are cut by jaws. The radula moves forwards and backwards to cut the food into small bits. The salivary secretions mix the food in the buccal cavity. The starches are digested and converted into sugars. In the stomach the secretions of the digestive gland act on the food. They digest the various substances. The cellulose is digested by a special type of cell present in the stomach wall known as the **resorptive cells**. Thus intracellular digestion also takes place in the animal. Absorption of digested food takes place mainly in the digestive gland and to some extent in the intestine.

15.6 RESPIRATORY SYSTEM

15.6.1 Aquatic Respiration

Due to amphibious mode of life *Pila* has respiratory organs for both aquatic and aerial respiration. Aquatic respiration is effected by the **ctenidium** when the animal is in water. The **ctenidium** is located in the mantle cavity. It is provided with a single row of thin triangular filaments called the **lamellae**. Such ctenidium with a single row of lamellae is known as **monopectinate** or **pectinibranch**.

During the process of aquatic respiration the two nuchal lobes form channels allowing the water to pass into the branchial chamber and pass out of the chamber. The incurrent water enters through the left nuchal lobe. The excurrent water comes out through the right nuchal lobe. The **osphradium** helps to test the purity of water.

15.6.2 Aerial Respiration

For aerial respiration the animal moves towards the surface of water. The left nuchal lobe elongates forming a tubular structure of about 20 mm long. This tube is known as **respiratory siphon**. Air enters through the siphon and fills the pulmonary chamber of the mantle cavity. The **epitaenia** presses against the mantle. The air enters the **pulmonary sac**. Exchange of gases takes place and the impure air is pushed out.

While moving on land *Pila* respire directly with the pulmonary sac. No respiratory siphon is formed here. Air enters through the left nuchal lobe.

During aecivation the animal shows extremely decreased respiratory activity.

15.7 BLOOD VASCULAR SYSTEM

The blood vascular system is complex. It is due to the presence of both the ctenidium and the pulmonary chamber. The system consists of the heart, the arteries, the veins and the sinuses (Fig. 15.6. A).

The pericardium is a thin-walled sac. It lies on the left side of the visceral mass. It is coelomic in origin. It communicates with the kidneys. The heart consists of two chambers an auricle and a ventricle. The aortic trunk arises from the ventricle and divides into two branches an anterior cephalic aorta and a posterior visceral aorta. A contractile aortic ampulla at the base of the cephalic aorta helps in propulsion of the blood. The heart, the aortic arches and the ampulla lie enclosed in the pericardium. The cephalic aorta supplies blood to the mantle, oesophagus, salivary glands, kidneys, foot and the sense organs. The visceral aorta supplies to the stomach, intestine, genital ducts and the rectum.

The blood from the various parts of the body pass on to small spaces called lacunae. The lacunae join together to form large sinuses. In some parts of the body the lacunar spaces are well marked. They resemble the renal capillaries connecting the arteries with the veins.

There are four chief sinuses in the body.

- (i) The anterior perivisceral sinus surrounding the anterior part of the alimentary canal.
- (ii) The peri-intestinal sinus - within the visceral mass surrounding the terminal part and along the coils of the intestine.
- (iii) The branchiorenal sinus - lying out side the anterior renal chamber.
- (iv) The pulmonary sinus - lying in the walls of the pulmonary sac.

15.7.1 Course of Circulation:

Blood is supplied to the various organs of the body through the various branches of the cephalic and visceral aortae (Fig. 15.7). It is then collected in the perivisceral and peri-intestinal sinuses. From the perivisceral sinus blood passes into the branchio-renal sinus. From here the blood passes either into the ctenidium and auricle or into the pulmonary sac and auricle. During aquatic respiration most of the blood passes along the ctenidium and during the pulmonary respiration along the pulmonary sac.

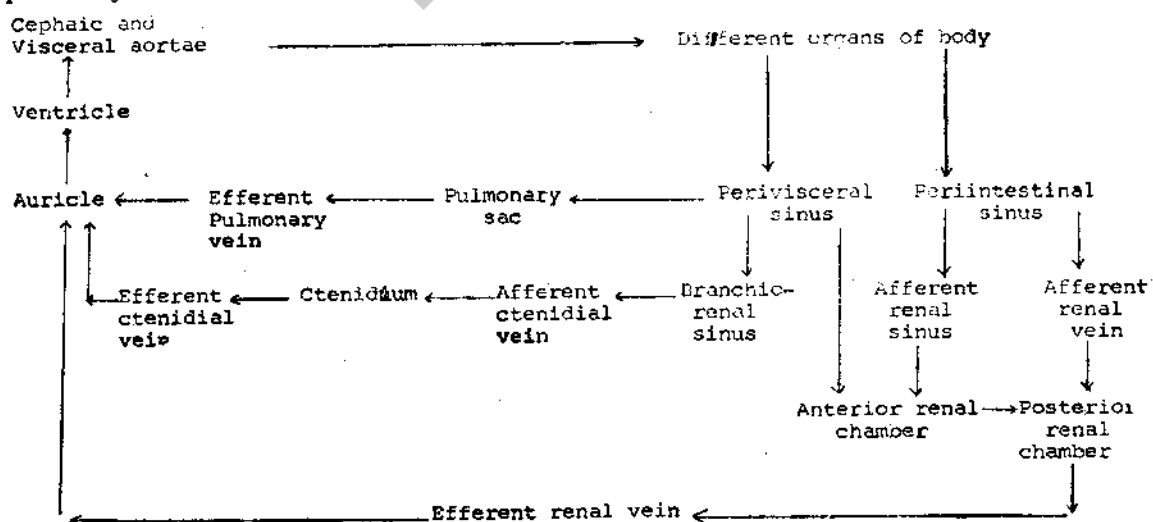

Fig. 15.7 *Pila globosa* — Course of blood circulation.

The blood from the peri-intestinal sinus enters the anterior and posterior renal chambers. After the removal of waste products the blood from the posterior renal chamber enters the auricle. The blood received into the anterior renal chamber enters the ctenidium and from there into the auricle. In *Pila* auricle gets both pure and impure blood.

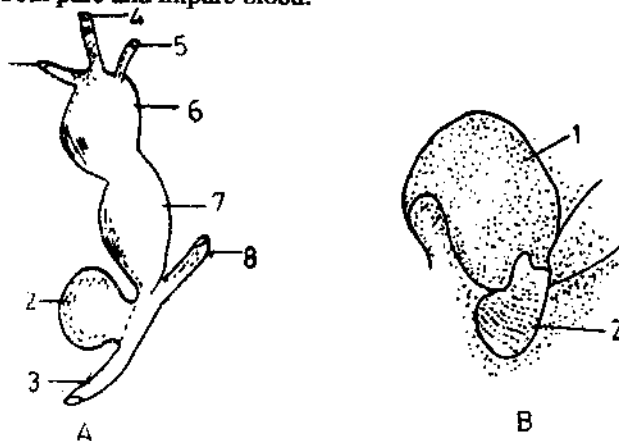

Fig. 15.6. *Pila globosa* A. Heart. 1. Pulmonary vein. 2. Aortic ampulla. 3. Cephalic aorta. 4. Efferent ctenidial vein. 5. Efferent renal vein. 6. Auricle. 7. Ventricle. 8. Visceral aorta. B. Renal organ. 1. Posterior renal chamber. 2. Anterior renal chamber.

15.8 EXCRETORY SYSTEM

The **renal organ** or **kidney** is the excretory organ in *Pila*. It consists of two chambers: (i) a small anterior chamber and (ii) a large posterior chamber. The two chambers communicate with one another by an aperture. This aperture is guarded by a valve. The anterior chamber is in front of the pericardium. It opens into the mantle cavity near the epitaenial ridge. The inner lining of the anterior chamber is thrown into leaf-like processes known as the lamellae.

The posterior chamber lies to the left of the rectum. Its cavity communicates with the pericardium by the **renopericardial aperture** (Fig. 16.6 B).

Both anterior and posterior renal chambers are richly supplied with blood vessels. The nitrogenous waste products are separated and discharged into the mantle cavity. Excretory matter contains mostly ammonia and some ammonium compounds, urea, and uric acid.

15.9 NERVOUS SYSTEM

The nervous system of *Pila* consists of paired cerebral ganglia, pedal ganglia, pleural ganglia and unpaired suprainestinal ganglion, infraintestinal ganglion and visceral ganglion. Commissure, connectives and nerves are associated with these ganglia (Fig. 15.8).

The nerves connecting the similar ganglia of two opposite sides are known as commissures. Connective is the name applied to the nerves connecting two dissimilar ganglia.

A pair of **cerebral ganglia** lie anteriorly at the dorsolateral sides of the buccal mass. The two are connected by a thick commissure known as the **cerebral commissure**. Nerves from the ganglia are supplied to the snout, buccal mass, eyes, tentacles and the statocyst.

Ventrally on either side of the buccal mass a pair of ganglia called the **pleuro-pedal ganglia** are present. Each pleuro-pedal ganglion is formed by the fusion of pleural and pedal ganglia. The two pedal ganglia are connected by two pedal commissures one lying above the other. The pleural ganglia supply nerves to the mantle. The pedal ganglia supply to the foot. The cerebral ganglion of each side is connected with the pleuro-pedal ganglion of its side by two connectives called the **cerebro-pleural** and **cerebro-pedal connectives**. A delicate, thin nerve connects the two pleural ganglia. This nerve arises from the left pleural ganglion and joins the right pleural ganglion. Then it continues backwards as the right pleuro-visceral connective and joins the visceral ganglion. The

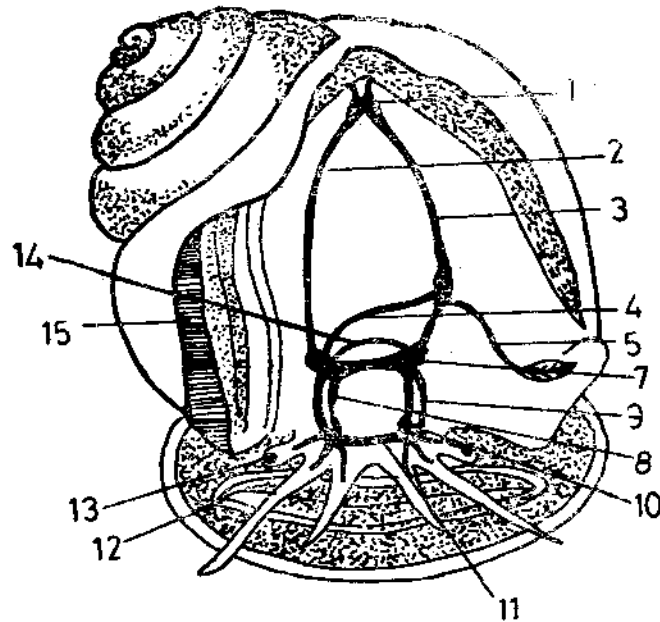

Fig. 15.8. *Pila globosa* — Nervous system. 1. Visceral ganglia. 2. Right pleural visceral connective. 3. Left pleuro-visceral connective. 4. Supra intestinal nerve. 5. Nerve to osphradium. 7. Pleural ganglion. 8. Cerebropedal connective. 9. Cerebropleural commissure. 10. Cerebral ganglion. 11. Cerebral commissure. 12. Foot. 13. Eye. 14. Infra-intestinal. 15. Ctenidium.

visceral ganglion is actually formed by the fusion of two ganglia. The right pleural ganglia gives off a nerve, the supra-intestinal nerve, which runs backwards over the oesophagus and forms a supra intestinal ganglion on the left side. The supra-intestinal ganglion is connected with the left pleural ganglion and visceral ganglion. In between these two the left pluro-visceral connective is formed. The visceral ganglia innervate the ctenidium, the pulmonary chamber, the digestive, the excretory and the reproductive organs.

A stomatogastric nerve ring is formed by a pair of buccal ganglia. They lie embedded in the muscles of the dorso-lateral side of the buccal mass. Ventral to the oesophagus, these two ganglia are connected by a delicate commissure known as the buccal commissure. Each buccal ganglion is connected to the cerebral ganglion of that side by a cerebro buccal connective. Thus a nerve ring encircling the buccal mass is formed. The anterior part of the digestive system is innervated by the stomatogastric nerve ring.

15.9 SENSE ORGANS

The sense organs of *Pila* consist of a pair of eyes a pair of statocysts, two pairs of tentacles and an osphradium.

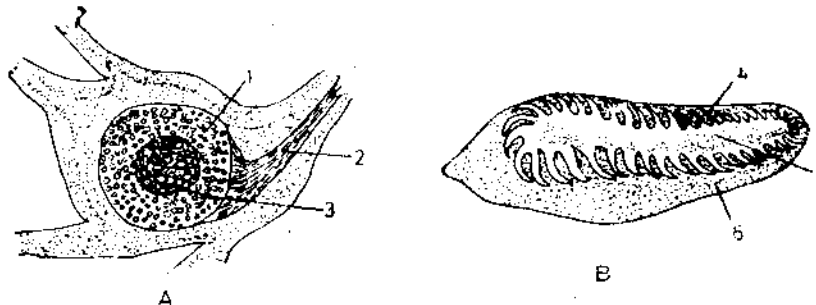

Fig. 15.9. *Pila globosa* A. Statocyst. B. Osphradium. 1. Capsule. 2. Nerve. 3. Statoliths. 4. Lateral filament. 5. Central axis. 6. Mantle fold.

Eyes are useful only to respond to variations in the intensity of light. A statocyst lies in connection with each of the pedal ganglia. It is an ectodermal capsule (Fig. 15.9) filled with a fluid containing a large number of calcareous particles called the statoliths. The statocysts are the organs of

equilibrium. Tentacles serve a tactile function. The **osphradium** lies suspended from the edge of the mantle on the left side of the animal. It is close to the entrance of water into the mantle cavity. It is oval in shape with a central axis and two rows of leaflets (Fig. 16.9 B) consist of epithelial cells some of which are sensory, some ciliated and others glandular. The osphradium enables the animal to test the purity of water entering the mantle cavity for respiration. If the water is foul and unfit for respiration the animal avoids the water and moves away to another area.

15.10 REPRODUCTIVE SYSTEM

Sexes are separate (dioecious). The females are larger than the male.

15.10.1 Male Reproductive System: In the male, the **testis** is cream-coloured. It lies closely attached to the digestive gland. Many minute vasa efferentia lead from the testis. They unite to form a **vas deferens**. The vas deferens is divisible into 3 parts: (i) The proximal thin-walled, tubular part, (ii) the middle swollen and curved part known as the **seminal vesicle** and (iii) the **terminal glandular part** lying to the left of the rectum. It opens into the mantle cavity close to the anus. The **penis**, a copulatory organ arises from the edge of the mantle. It is enclosed in a sheath known as the **penis sheath**. At the base of the penis sheath, there is a glandular thickening. The gland is known as **hypobranchial gland**. It has no duct and the secretions are directly poured on the penis and penis sheath (Fig. 15.10).

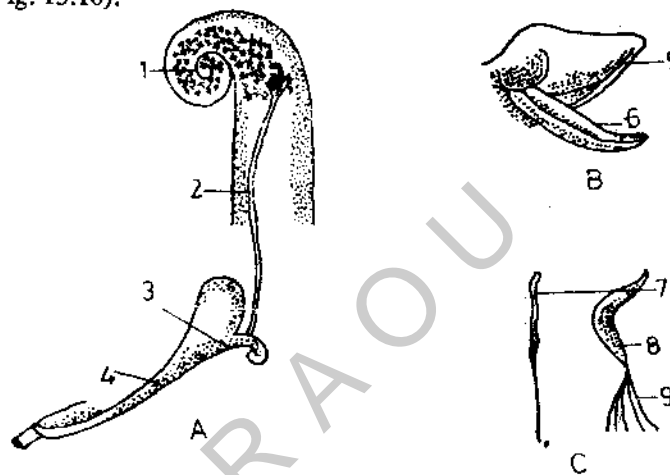

Fig. 15.10 *Pila globosa* — Male reproductive system. A. Reproductive organs. B. Copulatory organs. C. Spermatozoa. 1. Testis. 2. Narrow tubular vas deferens. 3. Seminal vesicle. 4. Glandular part of vas deferens. 5. Penis sheath. 6. Penis. 7. Eurypyrene sperm. 8. Oligopyrene sperm. 9. Four cilia.

The spermatozoa of the *Pila* are of two types (i) hair-shaped **eurypyrene sperms**, (ii) **Oligopyrene sperms** with prominent head. Eurypyrene sperms alone are capable of fertilizing the eggs.

15.10.2 Female Reproductive System The ovary is also located close to the digestive gland as is

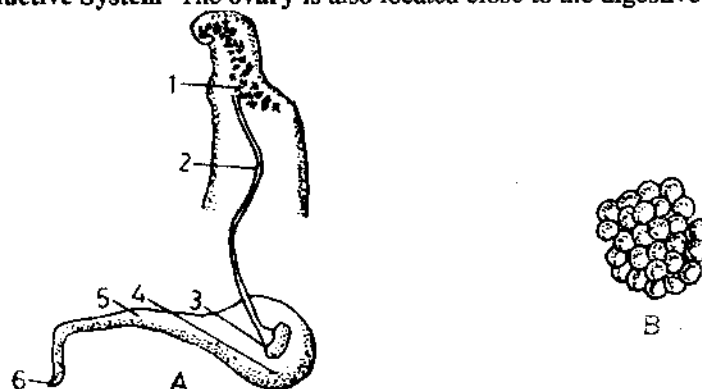

Fig. 15.11. *Pila globosa* — Female reproductive system. B. Egg mass. 1. Ovary. 2. Oviduct. 3. Seminal receptacle. 4. Uterus. 5. Vagina. 6. Female genital pore.

the testis in the male. It is orange coloured in the young, but becomes black in the mature animals. An oviduct leads from the ovary and extends downwards along the digestive gland to open into seminal receptacle (receptaculum seminis). The seminal receptacle opens into the uterus which lies closely attached to it. The uterus is yellow in colour. It is continued into the vagina. The vagina opens into the mantle cavity close to the anus. In the female hypobranchial gland is poorly developed (Fig. 15.11).

15.10.3. Copulation and Oviposition

Snails breed during rainy season. Copulation takes place in the ponds or outside. It continues for 3 hours or more. The sperms are transferred to the seminal receptacle. Fertilization is internal. Eggs are laid in large masses of 200 to 800 days after copulation in moist earth near ponds and lakes.

After development the young ones hatch out of the eggs. In freshwater and terrestrial molluscs there is no free swimming larva. The other gastropod molluscs in their development pass through two larval stages. The first stage is the trochophore larva. The trochophore soon grows into a veliger larva. The veliger is the characteristic gastropod larva. It is a modified version of the trochophore.

Check Your progress

1. Gastropods are certainly the most successful of the molluscan classes since many members have adopted life.
2. The phenomenon where the body behind the head of *Pila* is twisted 180° counter clockwise is known as This changes bilateral arrangement of organs into asymmetry.
3. A highly developed feeding organ in the buccal mass is called as

15.11 SUMMARY

Pila globosa is the common apple snail. In describing the external characters the nature of gastropod shell is illustrated. The organs in the pallial complex are ctenidium, rectum, genital duct, epitaenial ridge etc. The digestive organs including the digestive gland described. *Pila* performs branchial as well as pulmonary respiration. Hence it is able to lead successfully amphibious life. Corresponding with the two types of respiration, the circulatory system is also well developed. Excretion by structure called renal organs Nervous System with number of paired ganglia and nerve connections, commissures and connectives. Sense organs are eyes and statocyst. Osphradium to test the purity of water is also present. Sexes are separate. Reproductive system well developed. Development indirect. Larval form called veliger present.

15.12 CHECK YOUR PROGRESS — MODEL ANSWERS

1. amphibious
2. torsion
3. radula

15.13 MODEL EXAMINATION QUESTIONS

I. Answer the following in about 30 lines:

1. Describe the digestive system of *Pila*. Add a note on the physiology of digestion.
2. Describe the blood vascular system of Apple snail.
3. *Pila globosa* is amphibious. How is it suited to life both in water and on land regarding respiration?
4. Describe the nervous system of *Pila*.
5. Describe the reproductive system of *Pila*. Add a note on its development.

II. Answer the following in about 10 lines:

1. Describe the shell of *Pila globosa*.
2. Describe the excretory system of *Pila*.

UNIT - 16 ECONOMIC IMPORTANCE OF MOLLUSCA

Contents:

- 16.1 Objectives
- 16.2 Introduction
- 16.3 Molluscs as Food
 - 16.3.1 Gastropods
 - 16.3.2 Bivalves
 - 16.3.3 Cephalopods
 - 16.3.4 Molluscs as food for marine life
- 16.4 Medicinal Uses
- 16.5 Ornaments and Jewellery
- 16.6 Lime Manufacture
- 16.7 Other Uses
- 16.8 Harmful Molluscs
- 16.9 Pearl Oysters
- 16.10 Pearl Culture
- 16.11 Summary
- 16.12 Check Your Progress - Model Answers
- 16.13 Model Examination Questions
- 16.14 Glossary

16.1 OBJECTIVES

To know that the molluscans contribute a lot to the economy of man by providing him with a wide variety of useful things. At the end of this unit you will know the economic importance of molluscs, useful and harmful molluscs, Pearl culture etc.

16.2 INTRODUCTION

A large number of species of molluscs are found in India. They occur in the sea, in brackish and fresh water and on land. Some of them are of considerable economic importance and are fished for food, for the pearls they yield and for their shells utilized in various ways.

16.3 MOLLUSCS AS FOOD

16.3.1 Gastropods:

Among the edible gastropods, limpets are collected for food in some parts of east coast of India. The more common among them are *Cellana radiata*. The flesh of ear-shell (*Haliotis*) is esteemed as food. It is found attached to rocks and boulders at and below low tide level and seldom exceeds 38 mm. in length (Fig. 16.1 A) Among the top shells (Trochidae), the flesh of *Trochus niloticus* and *T. stellatus* is eaten in South India. The turban shells *Turbo brunneus* and *T. marmoratus* (Fig. 16.1 B.) are preferred in some areas. Large quantities of button shell, *Umbonium (Rotella) vestianum*, are collected along the Bombay coast and eaten as a delicacy.

The flesh of the apple snail, *Pila globosa* (Fig. 15.1.) is collected and eaten in several districts in Andhra Pradesh and Tamil Nadu. The snail is commonly found in lakes, tanks, marshes, ponds and paddy fields.

Horn-shells (Cerithiidae) are esteemed as whole-some food in the Philippines. The only species used as food in India is *Telescopium telescopium* found in abundance in the swamps of Gangetic, Krishna and Godavari deltas and also of the Konkan coast.

Two species of wing-shells, *Strombus canarium* and scorpion-shell or five fingerd chank *Lamibis (Pterocera) lambis* (Fig. 16.1 C.) are commonly collected for food.

The flesh of the sacred chank *Turbinelia pyrum* is eaten (Fig. 16.1 D) dried, fried and in curries in some coastal area.

The great melon-shell, *Melo indica* is utilized for food. The adult melon-shell is globular in shape and attains a length of nearly 20 cm. It is found all along the Indian Coast, but is particularly common in the Palk Bay at a depth of 5 to 6 fathoms, (9 to 11 m.)

The olive shells extensively utilized as food by fishermen belong to *Oliva* species (Fig. 16.1 E). They are common in the East Coast of India but scarce on the west coast. The main collecting season is February - April. The catch is boiled in fresh water to extract the flesh to be used either in curry or fried in oil.

16.3.2 Bivalves

Bivalves most commonly utilized for food include edible oysters, sea-mussels and clams. All important commercial species of edible oysters belong to the genus *Crassostrea* and are in demand in cities like Bombay, Calcutta and Madras.

The blackwater oyster, *Crassostrea madrasensis*, is widely distributed in all estuaries and blackwaters of the east coast. It is good food readily available from the vast natural resources.

Two species of sea-mussels grow to a large size in Indian waters. These are the brown mussel and the green mussel, *Mytilus* spp. These are consumed by fishermen on the east coast. The flesh is usually eaten after boiling with tapioca roots of rice. It is dried in the sun without losing glycogen or protein. The dried material is tasty and keeps good for a number of days.

The important clams used as food are blackwater clams (*Meretrix* spp. Fig. 16.1 F & G), clams (*Gaprarium* spp), false clams (*Paphia* spp.) and black clam (*Velorita* spp).

Meretrix spp occurs in extensive beds and is collected in abundance from all estuaries and backwaters of both the coasts. It is as important a food mollusc as edible oysters. Clams are generally marketed alive.

The ribbed ark-shell, *Arca granosa* (Fig. 16.1 I) is widely distributed in sandy blackwaters and estuaries along the Indian coast. Its flesh is red and though tough, it is considered to be nutritious.

The true scallop, *Chlamys senatoria* inhabits deep waters. It is believed to possess a high food value. The fresh water mussel, *Lamellidens marginalis* (Fig. 14.2. A) is widely distributed and used as food. The wedge shells or wedge clams, *Donax cuneatus* and *D. scortum* are greatly valued as food by fishing communities.

Holywater clam or giant clams belonging to the genus *Tridacna*, the species of razor-shell, *Solen* (Fig. 14.2 G) are sometimes eaten.

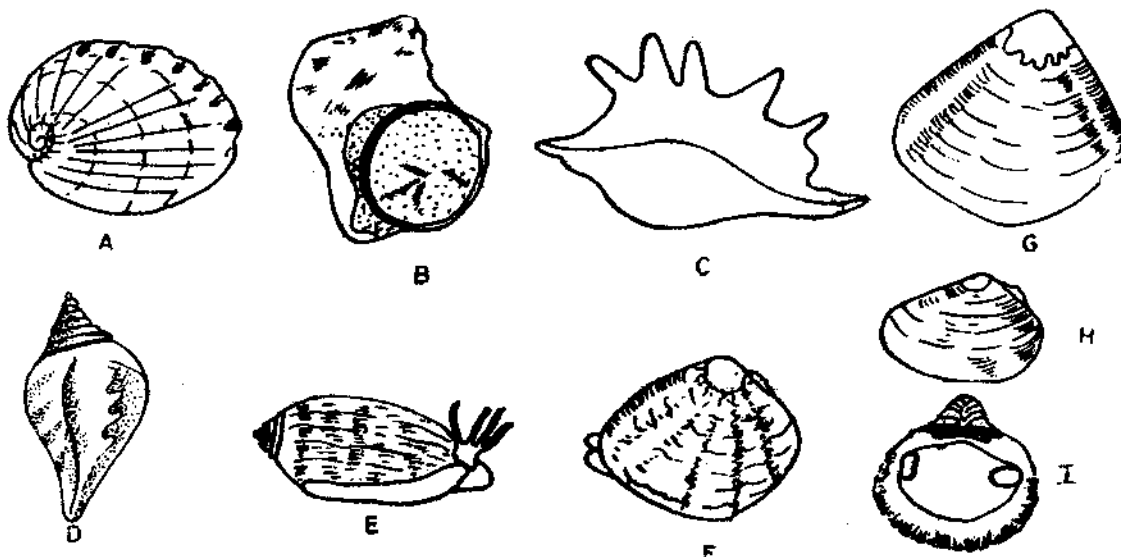

Fig. 16.1. A few Molluscs of economic importance. A. *Haliotis*. B. *Turbo marmoratus*. C. *Lambis* sps. D. *Turbinella pyrum*. E. *Oliva* sps. F. *Meretrix meretrix*. G. *Meretrix casta*. H. *Donax* sps. I. *Area granosa*.

16.3.3 Cephalopods

The edible cephalopods found in Indian waters are not many. A few cuttlefishes, *Sepia* sps. (Fig. 14.3 A) a few squids belonging to the genus *Loligo* (Fig. 14.3 B) and a few species of *Octopus* (Fig. 14.3 C) are the cephalopods which are commonly used as food.

All molluscs are prepared suitably to the taste before they are consumed. The meats of gastropods, oysters, clams and mussels in their fresh condition are stewed or treated with spice and fried or made into curries. The flesh of squids and the flesh of chanks are sun-dried. Later these are prepared as in the case of fresh ones after softening them by soaking in water.

16.3.4 Molluscs as food for marine life

Molluscs also serve as valuable food for various marine fauna. The larvae of the bivalves and the young or smaller forms of a few gastropods appear in abundance as zooplankton. Commercial species of fish depend upon these plankton for their food. The bottom-dwelling fish like the skates and rays feed mostly on the bivalves and gastropods whales and porpoises feed on shoals and other cephalopods.

Cuttlefish, squids and octopods are cut into strips and used as efficient baits in hook and line fishing.

16.4 MEDICINAL USES

The sacred chank, *Turbinella pyrum* is widely used in the indigenous system of medicine. After burning, the residual lime is used for dyspepsia, piles, general debility and some skin and lung diseases. The soft parts of the chank are used for spleen enlargement in some parts of India. Cowries such as a *Cypraea* sps. (Fig. 14.1 G) are more or less used for similar purposes. The flesh of apple snail, *Pila globosa* is used for sore-eyes in S. India.

Seed pearls produced by the withdowpane oyster, *Placuna placenta*, are used in the treatment of eye diseases. The flesh of the edible oyster, *Crassostrea madrassensis* is acrid and used to cure gastric disorders. Large quantities of sea-mussels are utilized in the manufacture of vitamin products Cuttlefish bones of *Sepia* are used as astringent and sedative.

16.5 ORNAMENTS AND JEWELLERY

Molluscan shells are extensively used in the manufacture of fancy goods and art pieces. The mother

of pearl lining of the earshell *Haliotis* *sps.* is attractively coloured and is used in decorative inlaid work, lacquer work, handles for cutlery, trays etc. The shell of *Trochus niloticus* and *Turbo marmoratus* are popular in the manufacture of pearl buttons, studs, broaches and other ornamental ware. The large pearly shell of *Turbo marmoratus* is employed by jewellers in India and Japan. It is also used in the ornamentation of screens, boxes and trays, and aquamarine work of Jaipur. The opercula of some *Turbo* species are stout massive and planoconvex. They are also large and heavy enough to be used as paper weights.

Many species of gastropods are used in the manufacture of ear rings, necklaces, rings and ornamenting belts, shields crosses etc. Large quantities of polished shells are also exported to Europe.

The shell of a species of *Triton* is used as a trumpet and as a musical instrument most commonly in temples.

Helmet shell, *Cassis cornuta*, the largest and heaviest among the Indian gastropods weighs nearly 2 kg and grows to a length of 15 cm. It is usually found in the Gulf of Mannar around Laccadives. The shell substance consists of several layers, all differently coloured. So it is well suited for cameo-carving.

Chank shells are used for preparing bangles, pendants, beads, rings and a variety of other articles. The operculum is made into a paste and used in incense sticks.

The shells of gastropods of the genera *Cymbium*, *Dolium*, *Pterocera* and *Murex* are used as lamp shades.

Because of their beauty of form and colour markings, molluscan shells have been favourite objects with cario collectors. Rare shells like that of *Conus* *sps.* fetch exorbitant prices. Shells of *Melo* *sps.* are handsome. Small cowries and other gastropod shells of the genera *Trochus*, *Nerita*, *Mitra* etc. are commonly used in indoor games in India.

Among bivalves the shell of window pane oyster *Placuna placenta* is used for glazing windows and verandah roofs. The shell is soft and when immature resembles mica in appearance and substance. Cheap quality pearls are also produced by this oyster.

The common fresh water mussel, *Lamellidens marginalis* produces pearls of fair quality in large numbers. They are collected and sold in South India. *Mytilus* (Fig. 14.2 B), the green sea mussel also produces pearls.

Among cephalopods shells of pearly nautilus are used in decorative ware, ash trays, lamp shades etc. The cuttlebone of *Sepia* is used as polishing material of glass and other fine wood. Ink sac of *Sepia* is collected to prepare a dark brown pigment called sepia. It is extensively used in photography and art work. Ink sacs of squids are used in the preparation of an ink which is permanently black. It is used chiefly in water-colour painting.

16.6 LIME MANUFACTURE

The production of lime from shells of molluscs is an important industry in the coastal areas of India. Shells of various species of bivalves and gastropods are gathered from the shores by fishermen and sold to lime manufacturing units. Lime produced by burning molluscan shells is of superior quality for use in masonry construction and white - washing. It is used also as a fertilizer. In Kerala state the shells are directly used for the production of high grade cement.

16.7 OTHER USES

Some of the shells, such as *Placuna*, *Spirula*, *Dolium* etc. are used in the manufacture of tooth pastes. Waste shells of *Trochus*, *Turbo* and cuttlebone of *Sepia* are used in tooth powders.

16.8 HARMFUL MOLLUSCS

This description will not be complete if a few molluscans which are harmful are also not described. Marine borers *Pholas* and *Teredo* of Bivalvia cause considerable damage to underwater wooden construction. The sea fishing industry which depends mainly on wooden boats and catamarans suffer an annual loss of about a crore of rupees as a result of borer damage.

Teredo Fig. 14.2 F, the shipworm, attains a length of one metre or more with a diameter of 6.3 mm. They start burrowing in the wood, when quite tiny, and continue to live in the burrow. Even the hardest and high quality wood is not immune to the attack of these borers. To save the ships or boats it is essential to protect the underwater woodwork by metal sheathing or suitable coating compositions. Large amounts on chemical preservatives and other oils are spent to keep away these wood-borers.

Achatina fulica, the big land snail is a pest of vegetable gardens. *Vaginula*, the land slug is a serious pest of vegetable crops like brinjal, tomato, cauliflower, cabbage, etc. Some genera of freshwater snails act as intermediate hosts of dreadful helminth parasites, particularly of digenetic trematodes.

16.9 PEARL OYSTERS

Pearl oysters are all marine and belong to a single genus *Pinctada*. Five distinct species of *P. fucata* (*P. vulgaris*) (Fig. 14. I.D.), *P. margaritifera*, *P. chemritzi*, *P. anomioides* and *P. aatropurpurea* are known to occur in Indian waters. Of these *P. fucata* (*vulgaris*) is by far the commonest and the most important and is widely distributed in the Gulf of Kutch, Gulf of Mannar and the Palk Bay.

Pearl oysters possess a straight long hinge uniting the two valves, the lower valve being a little deeper than the upper. The shell at either end is distinctly marked off from the rest into two small ear regions, one anterior and the other posterior in relation to the hinge. A bunch of threads known as the byssus arising from the basal region of the foot help the animal to fix to the substratum. The internal surface of the valves is of a brilliant lustre.

Pearls are calcareous concretions formed as protection against the irritation caused by foreign objects. These could be either bits of gravel or minute parasites, which lodge inside between the mantle and the shell of the animal. The common parasites found in the pearl oysters of India is the larval cysts of the tapeworm, *Tentacularia unionifactor*. A fold of tissue envelops the foreign particle and deposits layer after layer of nacre (mother of pearl) on it.

Pearl oysters are usually found on the ridges of rocks of dead corals forming extensive pearl banks or the pars at a depth of 10 to 12 fathoms (18 to 22 mt) and a distance of 19 km from the shores. The pearl oyster bed of the east coast are more extensive and productive than those of the west coast. The most productive zone in the east coast is near Tuticorin. These yield excellent quality pearls or the lingha pearls.

Pearl oysters grow 8-9 to 10.2 cm across in 4 to 5 years when they are ready for harvesting. As the pearl yield from young oysters is low, strict legislative measures are in force forbidding their fishing. In South India pearl oysters are harvested by divers, but in the west coast (Kutch and Gujarat) they are exposed at low water spring tides and are easily collected by hand.

The pearl beds are under the control and supervision of respective State Governments. Fishing is conducted by organising temporary camps with the help of divers, owners of boats and their crew and pearl merchants. Divers descend into the waters of the pearl banks with the help of sinking stones operated by men on boats. They collect the oysters into small bags they carry. Nowadays special sophisticated equipment, such as aqua-lung is being used in the pearl fishery.

16.10 PEARL CULTURE

Pearl culture involves inducement of the oyster to secrete a pearly substance round a deliberately

introduced foreign body of the nature of shell bead. This foreign body is introduced by a delicate operation without much injury to the soft body. These oysters are taken care of from one to three years, till the process of the pearl formation is completed. Artificial pearl culture seem to be gaining popularity in view of the calamities, both biological and physical, prevailing in the natural oyster beds. However, systematic and careful watch is being exercised by the personnel so that natural resources do not go unfished when the oysters reach the fishable stage.

Check Your Progress

1. Pearl culture is of commercial importance based on oysters. Note the gastropod genera which tremendously damage the oyster beds.

16.11 SUMMARY

The shells and soft parts of molluscans are useful to man in many ways. Molluscs form an important item of food in many coastal areas. Many kinds of ornament and decorative art ware are manufactured by making use of the lustrous shells. Shells are used in the manufacture of lime. A few molluscans which adversely affect the economy are also discussed. Oysters which produce pearls are described in detail. Pearl is formed as a result of antigen-antibody reaction. Pearl culture, natural resources and artificial culture are explained.

16.12 CHECK YOUR PROGRESS — MODEL ANSWERS

1. Murex, Urosalpinx.

16.13 MODEL EXAMINATION QUESTIONS

1. List out the various uses of Molluscs in about 30 lines.
2. Write about pearl oysters and pearl culture in about 10 lines.

16.14 GLOSSARY

Aestivation	: Summer sleep by animals to tide over drought conditions particularly extreme heat.
Backwaters	: A pool or belt of water connected with sea the level of which changes with the tide.
Bioluminescence	: The emission of light by living organisms.
Brackishwater	: Water with different degrees of salinity usually met with in estuaries.
Byssus	: Foot in a few bivalves is modified into number of thread-like structures useful for attachment. (<i>Mytilus</i>)
Commissure	: Nerve fibres connecting similar ganglia
Connectives	: Nerve fibres connecting dissimilar ganglia
Ctenidium	: Respiratory organs of molluscs, with a central axis and filaments on either sides or one side only.
Dioecious	: (Di = two; oikos = houses) when sexes are located in separate individuals.
Direct development	: Embryonic development without larval stages. The young on hatching has the adult form.
Estuary	: The wide lower tidal part of the river (usually known as the river mouth).
Haemocyanin	: Copper containing respiratory pigment in the blood of molluscs and crustaceans.
Indirect development	: Having larval stages in the course of development.
Living fossil	: An animal now living retaining the characters of primitive or

	: ancient animals.
Metamorphosis	: A process of development in which the young one, the larva, transforms into an adult undergoing gradual changes.
Monopectinate	: Gills or ctenidia having filaments in a single row as in <i>Pila</i> .
Plankton	: Minute free floating organisms without any ability to swim about. Their movement depends on the wave action or current of water.
Odontophore	: An elevated ridge present on the floor of the buccal cavity of <i>Pila</i> .
Ommatophore	: Short stalks present on either side of the head of <i>Pila</i> . Each bears an eye at its tip.
Oviparous	: Animals which lay eggs.
Ovoviviparous	: Production of eggs that are retained and hatched within the mother's body. Young are released at birth.
Pallial complex	: Organs found in the mantle cavity in <i>Pila</i> .
Radula	: A horny, ribbon-like rasping organ in the buccal cavity of many molluscs.
Sinuses	: Hollow spaces in which the blood flows in the absence of blood vessels.
Torsion	: Spiral coiling of the viscera which becomes asymmetrical.
Zooplankton	: Minute free floating animals.

BRAOU

UNIT - 17 ARTHROPODA — GENERAL CHARACTERS AND CLASSIFICATION

Contents

- 17.1 Objectives
- 17.2 Introduction
- 17.3 General Characters
- 17.4 Classification
 - 17.4.1 Sub-phylum - Onychophora
 - 17.4.2 Sub-phylum - Tardigrada
 - 17.4.3 Sub-phylum - Pentastomida
 - 17.4.4 Sub-phylum - Trilobitomorpha
 - 17.4.5 Sub-phylum Chelicerata
 - 17.4.5.1 Class - Merostomata
 - 17.4.5.2 Class - Arachnida
 - 17.4.6 Sub-phylum - Pycnogonida
 - 17.4.7 Sub-phylum - Mandibulata
 - 17.4.7.1 Class - Crustacea
 - 17.4.7.2 Class - Pauropoda
 - 17.4.7.3 Class - Diplopoda
 - 17.4.7.4 Class - Chilopoda
 - 17.4.7.5 Class - Symphyla
 - 17.4.7.6 Class - Insecta
- 17.5 Summary
- 17.6 Check Your Progress - Model Answers
- 17.7 Model Examination Questions

17.1 OBJECTIVES

To survey the vast assemblage of animals included in the phylum and thereby understand the relationship among the different groups. At the conclusion of this unit you will be in a position to explain the diversity and ability of these animals which adapted to living on land successfully.

17.2 INTRODUCTION

Phylum Arthropoda (Arthros : jointed; podos : foot) is a large assemblage of animals. Von siebold named the group Arthropoda because it included animals with jointed legs. It is represented by over nine lakh species of animals, which is three times more than the number of all other animal species put together. They are the most successful animals because they have adapted to various habitats such as air, water and land. The arthropods include free living animals, parasites and commensals.

17.3 GENERAL CHARACTERS

1. Arthropods are bilaterally symmetrical, triploblastic, haemo-coelomate animals.
2. The body is metamericly segmented, some of the segments fuse to form distinct regions of the body namely head, thorax and abdomen.
3. Each segment usually bears a pair of jointed appendages. The segments of an appendage are known as the podomeres. The podomeres are connected to one another by articular membrane called the arthrodial membrane. As a result of such an arrangement a joint is created at each junction. Such joints enable the segments of the appendages, as well as those of the body to move.
4. One of the most distinguishing feature of the phylum is the presence of exoskeleton or cuticle which covers the entire body. Basically the cuticle of each segment is divided into four primary

plates a dorsal **tergum**, two lateral **pleura** (sing, pleuron) and a ventral **sternum**. The cuticle is a complex of mucopolysaccharide, chitin and proteins.

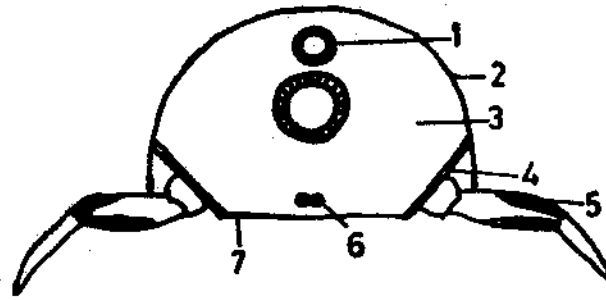

Fig. 17.1 General organization of an Arthropod. 1. Dorsal heart. 2. Tergum (dorsal exoskeleton). 3. Haemocoel. 4. Pleuron. 5. Jointed appendage. 6. Ventral double nerve cord. 7. Ster num.

5. During the growth stage, the exoskeleton is dropped off periodically after the development of a new one beneath. This process is known as **moulting** or **ecdysis**.
6. All arthropods possess an extensive **haemocoel** (Fig. 17.1) because the perivisceral cavity is filled with blood. The true coelom is reduced in the adult and is associated with the reproductive system and certain glands.
7. Musculature is mostly composed of striated muscles capable of rapid contraction.
8. The digestive system consists of **foregut**, **midgut** and **hindgut**. The foregut and hindgut are lined by chitinous ectodermal lining, and are known as **stomodaeum** and **proctodaeum** respectively.
9. Respiration is carried out by different methods. In the aquatic arthropods the respiratory organs are **gills**. In terrestrial animals gas-exchange is affected by respiratory tubes called tracheae. In some arthropods **book gills** (gill books) and **book lungs** serve the respiratory function.
10. Blood vascular system is of the **open type**. Distinct blood vessels are absent. Main blood vessels open into spaces in the perivisceral cavity. The heart is dorsal, usually tubular with lateral valvular openings called **ostia**.
11. Excretory organs are **malpighian tubules** or **antennary** or **green glands**. Some arthropods have maxillary glands functioning as excretory organs.
12. Nervous system is of annelid type with **paired ganglionic masses** located dorsally in the head. A nerve ring and **ventral nerve cord** are present.
13. Sense organs are fairly well developed. **Antennae**, **eyes** and **balancing organs** are usually seen in many arthropods.
14. **Sexes are separate**. In most of the cases there is a distinct sexual dimorphism. Fertilization is internal. Development is direct or indirect. In those species, where development is indirect there is a **metamorphosis**. Larval forms are found in those undergoing metamorphosis. In a few examples development takes place **parthenogenetically**.
15. Arthropods are economically very important.

17.4 Classification

In view of the differing views concerning the phylogeny of Arthropoda there is no definitive system of classification for the phylum. The classification described by Marshall and Williams (1979) is followed in the description here.

The phylum is divided into seven sub-phyla as follows:

Sub phylum	-	1	Onychophora
"	-	2	Tardigrada
"	-	3	Pentastomida
"	-	4	Trilobitomorpha
"	-	5	Chelicerata
"	-	6	Pycnogonidia
"	-	7	Mandibulata

Onychophora, Tardigrada and Pentastomida show doubtful or only superficial relationship with other arthropods. They are treated as subphyla by a few authors, while a few others treat them as separate phyla in a group of animals included as minor phyla. However, here these are treated as minor sub-phyla.

17.4.1 Sub-Phylum: Onychophora

Onychophora includes terrestrial arthropods. This is a group which diverged very early from the basic arthropodan stock. However they have retained certain characters which are helpful in tracing the ancestry of the group. All species were originally included in a single genus *Peripatus*. But now twelve different genera are recognised in two families. *Peripatus* is also the common name.

Distinguishing characters

These arthropods have the general body form of the annelids.

A firm exoskeleton is absent.

The body is divided into an anterior head followed by an unsegmented worm like body.

Jointed appendages are absent. However, numerous, short, unjointed, clawed, stumpy appendages occur in pairs.

The body wall is dermomuscular with soft, smooth, velvety skin.

Body cavity is a haemocoel.

Respiration is carried out by tracheal system.

Heart is tubular with ostia.

Excretory organs are nephridia.

Nervous system is ladder-like

Sexes always separate, development direct without any larval stages.

Geographical distribution is of considerable zoological interest. The group is a good example of discontinuous distribution.

Peripatus is considered as a connecting link between Annelida and Arthropoda, because it bears the characters of both Annelida and Arthropoda.

A few authors prefer to raise the sub-phylum Onychophora to the rank of a phylum and this trend is being accepted by many.

Examples: *Peripatus* (Fig. 20.1), *Peripatopsis*.

17.4.2 Sub-Phylum: Tardigrada

The animals of Tardigrada are popularly known as bear-animalcules or water bears.

They are soft-skinned animals of minute size, not exceeding 1 mm. in length.

The body is vaguely segmented and not divisible into different regions.

The mouth is provided with a sucking proboscis.

There are four pairs of short, unjointed legs. Each leg has two or four claws.

The mouth is surrounded by papillae, the buccal cavity contains a pair of horny or calcified teeth.

The digestive system consists of mouth, muscular pharynx, narrow oesophagus, an extensive stomach and a short intestine. Anus is sub-terminal. A pair of salivary glands open into the buccal cavity.

Respiratory and circulatory systems are absent.

Malpighian tubules are the excretory organs.

Brain and Ventral nerve cord with four ganglia present.

Sense organs include two eye spots

Sexes are separate (dioecious). Gonads in both the sexes are saccular and open into the terminal part of the intestine. Females are often more numerous than the males. In some males are unknown (Echiniscus). Parthenogenesis is common.

Development is direct.

Examples: *Echiniscus*, *Macrobiotus*, (Fig. 17.2 A), *Hypsibius*

17.4.3 Sub-Phylum: Pentastomida

Pentastomida comprise a group of approximately 70 species. These are popularly known as 'tongue worms'.

All members of the subphylum are parasitic and live within the lungs or nasal passage of vertebrates such as snakes, crocodiles etc.

The body is 2 cm to 13 cm in length and bears anteriorly five short protuberances. The name pentastomid is derived from this.

Four of the five protuberances are leg-like and bear claws.

The digestive tract is straight and simple. The anterior end is modified to suck the blood by pumping action.

Respiratory, circulatory and excretory organs are absent.

The nervous system is similar to that of the annelids and the arthropods. Ventral nerve cord with paired metamericly arranged ganglia are present.

Sexes are separate (dioecious) Fertilization is internal. The embryonated eggs pass into the digestive system of the host and from there to the outside through the faeces of the host.

Intermediate host is present in the life cycle which is usually a fish, rodent or rabbit.

Larval development takes place within the intermediate host and involves a number of moultings.

Examples. *Cephalobaena* (Fig. 17.2 B), *Waddycephalus*, *Linguatula*

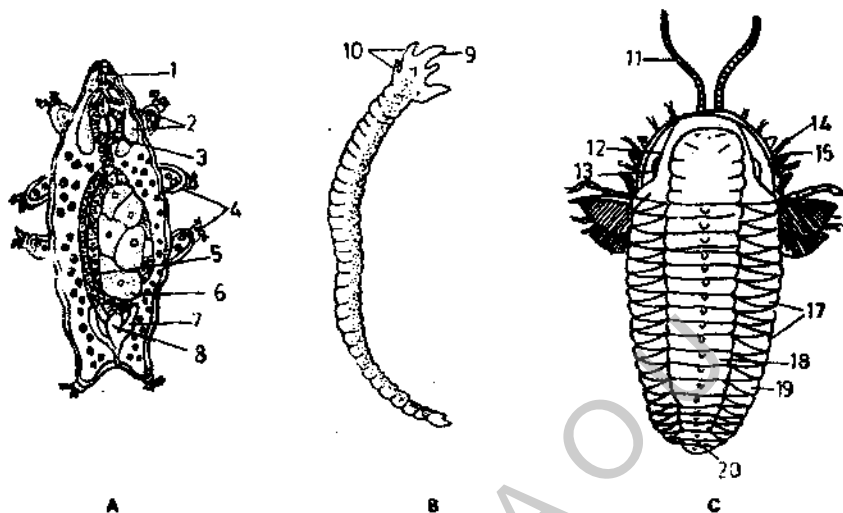

Fig. 17.2 Arthropods. A. *Macrobiotus*. B. *Cephalobaena*. C. *Triarthrus* (dorsal view). 1. Buccal cavity. 2. Salivary glands. 3. Pharynx. 4. Appendages. 5. Stomach. 6. Ovary. 7. Malpighian tubule. 8. Accessory gland. 9. Mouth. 10. Legs. 11. Antenna. 12. Cephalon. 13. Eye. 14. Telepod. 15. Pre-epipod. 16. Gill. 17. Thorax. 18. Axial lobe. 19. Pleural or lateral lobe. 20. Pygidium.

17.4.4 Sub-Phylum: Trilobitomorpha

The sub-phylum Trilobitomorpha is the most primitive of all known arthropodan groups. These are an extinct group of marine arthropods which were once abundant and widely distributed in Palaeozoic seas. Trilobite fossils are often found well-preserved because of their exoskeleton covering the dorsal surface. Respiratory organs are gill books, book-lungs, tracheae or skin (cutaneous).

The body of a trilobite was depressed, more or less oval in outline. It was usually 3 cm. long.

The body was divided into three regions — the head (cephalon or prosoma), thorax (trunk) and pygidium.

The head was covered by a carapace or cephalic shield.

The thorax was composed of a variable number (2-29) of movably articulated segments.

The pygidium was composed of variable number of segments, in a fused condition.

A pair of appendages were present in each of the segments, except in the anal segment.

Development is indirect. In their life history the trilobites passed through three larval stages, namely protaspis, meraspis and holaspis.

Examples: *Triarthrus* (Fig. 17.2 C), *Megaspis*, *Phacops*.

17.4.5 Sub-Phylum: Chelicerata

This group includes animals with a body divided into a cephalothorax (prosoma) and an abdomen (opisthosoma). Antennae are absent. The first preoral appendages are feeding structures called chelicerae. The first postoral appendages are called pedipalpi.

The chelicerates are derived from an early off-shoot from arthropod stock close to that of the trilobites. There are two classes in this sub-phylum. i) Merostomata and ii) Arachnida. Some authors also include the Pycnogonidia in the Chelicerata because of their chelicerata-like first appendages.

17.4.5.1 Class: Merostomata

Aquatic and marine chelicerates.

Prosoma with chelicerae and five similar pairs of appendages.

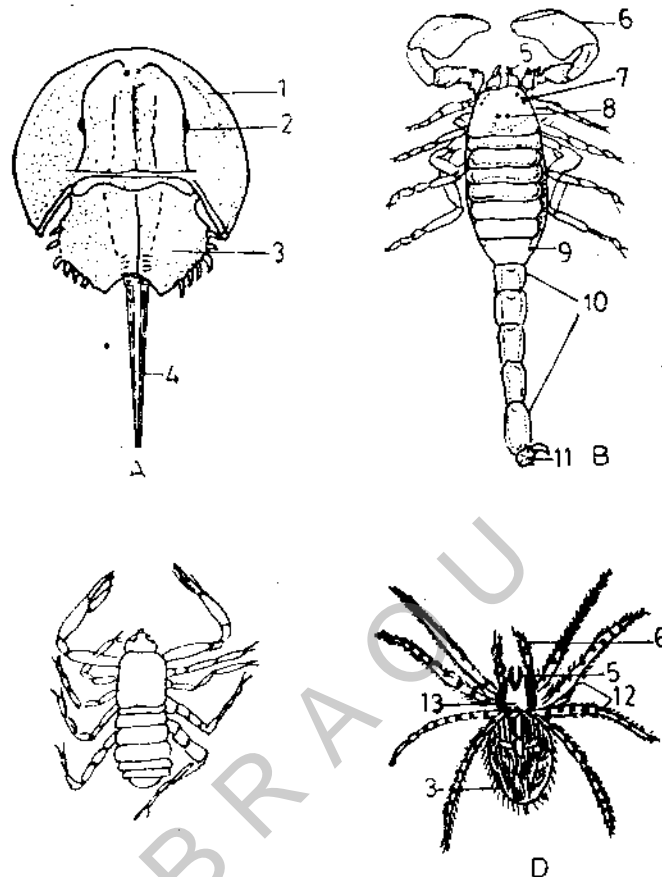

Fig. 17.3 Representatives of the sub-phylum Chelicerata. A. *Limulus*. B. *Palamnaeus*. C. *Chelifer*. D. *Aranea*. 1. Carapace. 2. Eye. 3. Abdomen 4. Telson. 5. Chelicera. 6. Pedipalp. 7. Lateral eye. 8. Median eye. 9. Mesosomal tergite. 10. Metasoma. 11. Sting. 12. Walking legs. 13. Cephalothorax.

Opisthosoma is divided into a **mesosoma** and a **metasoma**. The mesosoma is with five or six pairs of lamelliform appendages. The first forms a genital operculum. The others are modified as gills. The arrangement of the gills resembling the leaves of a book has drawn the name **gill book** or **book gills** to the respiratory structures.

Metasoma is without appendages but a spike-like telson is present.

Example: *Limulus* (King crab) — It belongs to an ancient sub-class Xiphosura of which most members are extinct. But *Limulus* has existed unchanged since the Triassic. Therefore it is called a **living fossil**.

17.4.5.2 Class : Arachnida

The arachnids comprise the largest and the most important of the chelicerate classes. May common and familiar forms such as scorpions, spiders, mites and ticks are included in this class.

The arachnid body is divided into two parts - an anterior **prosoma** (cephalothorax) and a posterior **opisthosoma** (abdomen).

The prosoma bears six pairs of appendages; the first pair are known as **chelicerae**, the second pair are **pedipalps** and the remaining four pairs are **legs**.

The opisthosoma has a pair of **pectines** in scorpions and **spinnerets** in spiders.

The alimentary canal characteristically has numerous **digestive diverticula**.

Respiration is by **lung books** (book lungs) or **tracheae** or **skin** (cutaneous).

Malpighian tubules are the excretory organs.

Development is usually direct without metamorphosis.

Examples: *Buthus* (House scorpion); *Palamnaeus* (Fig. 17.3 B) (Field scorpion), *Chelifer* (False scorpion) (Fig. 17.3) *Phalagium* (Harvestmen), *Lycosa* (Wolf spider); *Achacaranea* (House spider); (Fig. 17.3 D); *Sarcoptes* (Itchmite); *Ixodes* (ticks).

17.4.6. Sub-Phylum: Pycnogonida

These are marine, spider-like arthropods commonly known as **sea-spiders**.

The body consists of a **cephalothorax** composed of an anterior proboscis, three head segments and one thoracic segment followed by **three free thoracic segments** and a rudimentary **abdomen**.

The appendages consist of a pair of chelicerae, a pair of palps, a pair of ovigerous legs and four to six pairs of legs.

The body cavity is a **haemocoel**.

The intestines are very extensive. A long, lateral caecum extends into each appendage; in the legs extend almost their entire length.

Respiratory and excretory organs are absent.

The nervous system consists of brain, sub-oesophageal ganglion and three other ganglia in the cephalothorax.

Pycnogonids are dioecious. Females can be distinguished from males by the poorly developed condition of ovigerous legs or by their complete absence.

The testes extend from the thorax to the legs. The ovaries are completely enclosed in legs. The genital openings are found at the bases of the legs. The eggs are brooded by the males until they hatch.

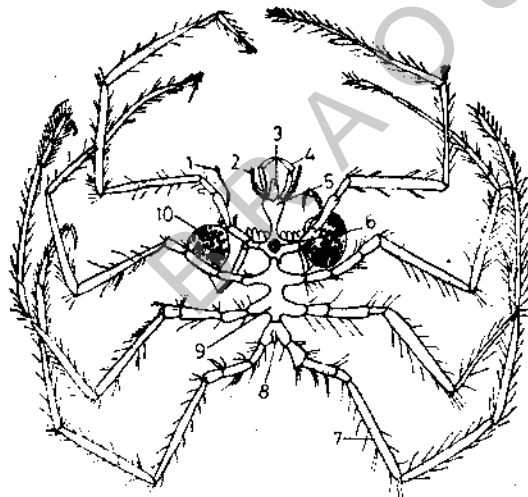

Fig. 17.4 *Nymphon*. 1. Ovigerous leg. 2. Palp. 3. Proboscis. 4. Chelicera. 5. Cephalon. 6. Eye. 7. Leg. 8. Anus. 9. Trunk. 10. Egg mass.

Metamorphosis occurs in many cases. The larva has three pairs of appendages bearing a superficial resemblance to a nauplius. The larva is called **protonymphon**. Most of the pycnogonids are bottom dwellers. They live in all oceans from the Arctic and Antarctic to the tropics.

Examples: *Nymphon* (Fig. 17.4), *Ascorhynchus*, *Pallene*.

17.4.7 Sub-Phylum: Mandibulata

The sub-phylum Mandibulata has been compiled to contain all those arthropods which possess **mandibles** and **antennae**. The body is usually divided into three parts — an anterior head, a middle thorax and a posterior abdomen. However, in myriapods the body consists of a head followed by a large number of similar segments. Antennae, mandibles and maxillae are present on the segments

of the head. Respiration is carried on by gills or trachea or skin. Excretion by antennary glands or malpighian tubules.

The Sub-phylum is divided into the following classes:

1) Crustacea, 2) Pauropoda 3) Diplopoda 4) Chilopoda 5) Symphyla 6) Insecta.

17.4.7.1 Class: Crustacea

The anterior 6 segments are fused to form a head.

Thorax and abdomen are formed by the remaining segments.

In some forms head and segments of the thorax fuse to form the **cephalothorax**.

The paired appendages in the head are **antennules, antennae, mandibles, first maxillae and second maxillae**.

The thoracic and abdominal appendages are variously modified to serve the functions of walking, swimming, feeding, respiration, accessory reproduction etc.

Appendages are typically **biramous** — **protopodite** is the basal segment, **endopodite** and **exopodite** are the two outer branches.

Body is covered by an **exoskeleton**.

Body cavity usually consists of a number of compartments filled with blood, thus forming a **haemocoelomic system**.

Blood vascular system is of the open type. Blood vessels (anterior) though present only lead up to the sinuses.

Excretory organs consist of one or two pairs of segmental organs. They are seen in the second antennal segment. They are termed as the **antennary or green glands**. If they occur in the maxillary segment then they are known as shell glands. Usually only one of the two glands are present in any one animal.

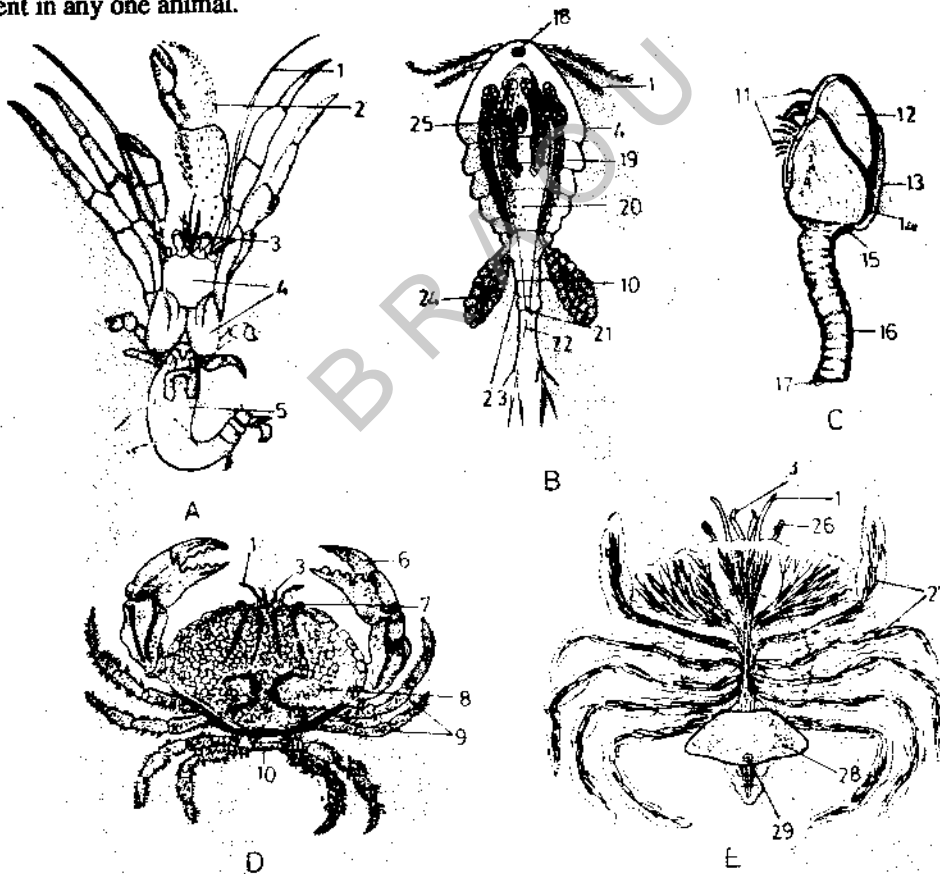

17.5 Representatives of the class Crustacea. A. *Eupagurus*. B. *Cyclops*. C. *Lepas*. D. *Cancer*. E. *Sacculina* (Root like processes seen spreading in the body of the host a crab). 1. Antenna. 2. Chelate leg. 3. Antennule. 4. Cephalothorax. 5. Soft abdomen spirally twisted to suit to the coils of the gastropod shell. 6. Chela. 7. Compound eye. 8. Carapace. 9. Thoracic legs. 10. Abdomen. 11. Thoracic appendages. 12. Tergum. 13. Carina. 14. Mantle. 15. Capitulum. 16. Pedicel. 17. Vestigial antennule. 18. Median eye. 19. Oviduct. 20. Midgut. 21. Anus. 22. Caudal styles. 23. Telson. 24. Egg sac. 25. Ovary. 26. Compound eye of crab. 27. Root like process of the parasite. 28. Sacculina. 29. Genital aperture of the sacculina.

Nervous system is typically arthropodan. It consists of a brain, oesophageal connectives and ventral nerve cord with segmental ganglia.

Sense organs are well developed — eyes, statocysts and different sensory receptors are of common occurrence.

Sexes are usually separate. There is a distinct sexual dimorphism.

Reproduction is by sexual method. In a few forms parthenogenesis occurs. Development is indirect with a complete metamorphosis. Number of larval forms are present. In a few others development is direct.

Autotomy and regeneration are of common occurrence.

The 26,600 species of the class Crustacea include some of the most familiar arthropods such as crabs, shrimps, lobsters, crayfish etc. In addition there are many more smaller forms inhabiting ponds and lakes, rivers and seas. These tiny forms have an important position in the aquatic food chain.

Examples: *Palaemon* (Freshwater prawn) (Fig. 18.1), *Penaeus* (Marine Prawn) (Fig. 20.1), *Panulirus* (Spiny lobster), *Eupagurus* (Hermit crab) (Fig. 17.5A), *Birgus latro* (Robber or Coconut crab), *Cancer* (a crab) (Fig. 17.5D), *Cyclops* (water flea) (Fig. 5B), *Balanus* (acom barnacle), *Lepas* (goose barnacle) (Fig. 17.5 C), *Sacculina* (parasitic) (Fig. 17.5 E).

17.4.7.2 Class: Pauropoda

Pauropods are **diognath** (two-jawed) **myriapods**, with **triflagellate antennae**.

Eyes are absent, but have curious organs called **pseudoculi** behind the antennae. These are sensitive to vibrations.

A pair of mandibles and one pair of maxillae are present.

Trunk of 11 or 12 segments with only 9-10 pairs of legs.

Tracheae are absent. Respiratory system is degenerate.

Heart absent. Circulatory system poorly developed.

They are gregarious, live under the bark of dead wood or in the soil.

Examples: *Pauropus* (Fig. 17.6 A) *Decapauropus*, *Brachypauropus*, *Eurypauropus*.

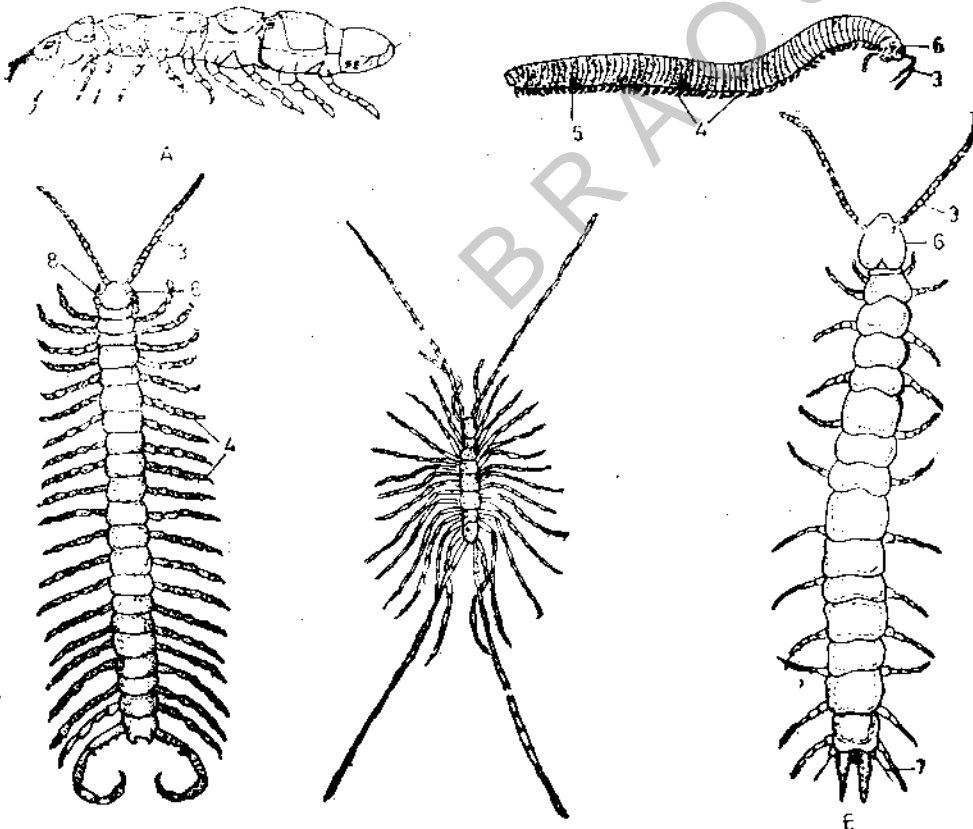

Fig. 17.6 A. *Pauropus*. B. *Julus*. C. *Scolopendra*. D. *Scutigera*. E. *Scutigera*. 1. Pygidium. 2. Collum. 3. Antenna. 4. Walking legs. 5. Opening of the stink gland. 6. Head. 7. Styles. 8. Poison claw.

17.4.7.3 Class: Diplopoda

The Diplopoda are Commonly known as millipedes. They are world-wide in distribution. Each trunk segment bears two pairs of legs suggesting the fusion of two segments into one. The mouth parts form a structure known as the gnathochilarium.

The exoskeleton is hard.

The digestive tract is typically a straight tube with a long mid gut.

Tracheae are the respiratory organs.

Heart is tubular. Each diplosegment has 2 pairs of ostia.

Malpighian tubules are the excretory organs.

Genital openings mid-ventral on third abdominal segment.

Examples: *Julus* (Snake millipede) (Fig. 18.6.B), *Spirobotus* (Snake millipede), *Siphonophora* (Suctorial millipede) -

Trignatha: The Chilopoda and Symphyla do not have many characters in common. In development a few show anamorphism. Young ones have seven podous segments when hatched.

17.4.7.4 Chilopoda

The chilopoda are commonly known as centipedes.

They are distributed throughout the world in both temperate and tropical regions.

The body is elongate and flattened dorso-ventrally.

Head bears a pair of antennae, one pair of mandibles and two pairs of maxillae.

Each trunk segment has a pair of legs. There is a progressive increase in the length of legs from anterior to posterior. This reduces interference with leg movement.

Respiration is by tracheal tubes.

The blood vascular system is of the open type.

Excretory organs are a pair of malpighian tubules.

Auditory sense organs called organs of Tomosvary are present at the base of antennae.

Sexes separate, genital opening mid-ventral on last but one segment.

Examples: *Scolopendra* (Fig. 17.6 C), *Scutigera*, (Fig. 17.6 D), *Lithobius*.

17.4.7.5 Class: Symphyla

Class Symphyla includes animals which superficially resemble the centipedes. They are commonly known as garden centipedes.

Body is divisible into head and trunk

Head with one pair of antennae, one pair of mandibles and two pairs of maxillae.

The trunk consists of 12 leg bearing segments. The last or the 13th segment carries a pair of spinnerets or cerci and a pair of long sensory hairs. The trunk terminates in a tiny, oval telson.

Genital openings mid-ventral between the 4th pair of legs.

Example: *Scutigera* (Fig. 17.6)

17.4.7.6 Class: Insecta

The Insecta or Hexapoda is the most extensive class in the Animal kingdom. It contains about 8 lakh species. It is larger than all other animal groups put together. Insects have invaded every habitable land environment. A few have successfully chosen the freshwater habitats. They are absent only in deeper salt water habitats. This successful existence is made possible firstly because of their ability to fly and secondly due to their body best adapted to prevent water loss. As the class is so diversified in habitat it is not possible to generalise the organisation. However, the characters described here give an idea of the basic structure of class.

The body of insects is divided into **head, thorax and abdomen,**

The head is formed by fusion of six segments. The thorax has three segments and the abdomen has about 11 segments.

The head consists of a pair of antennae, a pair of mandibles, 2 pairs of maxillae. The second pair of maxillae always fuse in the middle to form a composite structure called the **labium** or lower lip.

Head bears a pair of **compound eyes.**

Each segment of the thorax bears a pair of appendages; these are called legs.

Arboreal or flying insects have two pairs of wings on the second and third thoracic segments. Usually eleven segments are present in the abdomen. In a few insects a posterior telson also may be present.

Abdominal appendages such as ovipositors on genital segments and anal cerci in the posterior segment may be present.

Tracheae are the respiratory organs. They form an extensive net work within the body cavity for gas exchange.

During development most of the insects undergo a marked metamorphosis; In a few development is direct without metamorphosis.

Examples: *Lepisma* (Silver fish), *Periplaneta americana* (Cockroach), *Musca domestica* (Housefly), *Apis mellifera* (Honey bee), (Fig. 21.2), *Anopheles* (Mosquito), *Pediculus* (Headlouse), *Bombyx mori* (Silk worm moth) (Fig. 21.1).

Check Your Progress

1. Peripatus has many interesting similarities to both annelids and arthropods and restricted distribution. Evolutionary point of view it is considered as _____ and exhibits _____.
2. Millepedes and centipedes mainly differ in the pairs of legs. The former have _____ and the latter have _____ pair per segment.
3. Insecta is the largest group of animals. This success is certainly attributed to the evolution of _____ in them.

17.5 SUMMARY

Arthropoda include animals which have *jointed appendages*

The body is covered by a hard exoskeleton which is periodically cast off (*moulting or ecdysis*) to allow growth.

Body cavity is a *haemocoel*.

The blood *vascular system* is of *open type*.

Gills, tracheae and *book lungs* are the chief respiratory organs.

Antennary glands or *malpighian tubules* take up the excretory function.

During development many of them undergo profound *metamorphosis*.

The phylum is divided into seven sub phyla.

Peripatus, the onychophoran shows characters of two different phyla, so has attained a greater zoological importance as a connecting link.

Many economically important examples such as prawns, lobsters, crabs etc. are included in the group.

The phylum also includes important insects like honey bee, silkworm moth, lac insect etc. and also injurious insects.

King crab, a living fossil and scorpions and spiders are a few other representatives of this largest phylum of animal kingdom.

17.6 CHECK YOUR PROGRESS - MODEL ANSWERS

1. missing link, discontinuous distribution
2. two, one
3. flight

17.7 Model Examination Questions

I. Answer the following in about 30 lines:

1. Describe the general characters of phylum Arthropoda.
2. Describe the general characters of class Crustacea.
3. Describe the general characters of class Insecta.

II. Answer the following in about 10 lines

1. Describe briefly the classification of Arthropoda upto sub phylums and give few examples.
2. Describe the distinguishing characters of Onychophora.
3. How will you classify prawn, cockroach, scorpion and honey bee?

UNIT-18 PALAEMON (FRESH WATER PRAWN)

Contents

- 18.1 Objectives
- 18.2 Introduction
- 18.3 External Characters
 - 18.3.1 Cephalothorax
 - 18.3.2 Abdomen
- 18.4 Exoskeleton
- 18.5 Appendages
 - 18.5.1 Cephalic appendages
 - 18.5.2 Thoracic appendages
 - 18.5.3 Abdominal appendages
- 18.6 Digestive System
- 18.7 Respiratory System
- 18.8 Blood Vascular System
- 18.9 Excretory organs
- 18.10 Nervous System
 - 18.10.1 Sense organs
- 18.11 Reproductive System
- 18.12 Summary
- 18.13 Check Your Progress - Model Answers
- 18.14 Model Examination Questions.

18.1 OBJECTIVES

In this unit fresh water prawn is described in detail to know the general organisation of Phylum Arthropoda you will readily explain at the end that though prawn belongs to crustacean group. It is endowed with chitinous exoskeleton, jointed appendages, typical aquatic respiration and an open haemocoel — distinctive features of an arthropod.

18.2 INTRODUCTION

Palaemon, the fresh water prawn inhabits streams, lakes, ponds, pools and rivers all over India. The common Indian species of *Palaemon* are *P. malcolmsoni*, *P. carcius*, *P. lamarrei*, *P. rudis* etc. *P. malcolmsoni* is the common example studied as representative of the class Crustacea.

Systematic Position

Phylum	:	Arthropoda
Sub-phytum	:	Mandibulata
Class	:	Crustacea
Sub-Class	:	Malacostraca
Order	:	Decapoda
Sub-order	:	Macrura
Genus	:	<i>Palaemon</i>
Species	:	<i>P. malcolmsoni</i>

18.3 EXTERNAL CHARACTERS

The body of *Palaemon* is elongated and spindle-shaped and bilaterally symmetrical (Fig. 18.1): It is

well adapted for swimming. The size of the adult prawn varies from 2.5 cm to 50 cm. The colour of adult prawn is pale blue or greenish with brown or orange red patches.

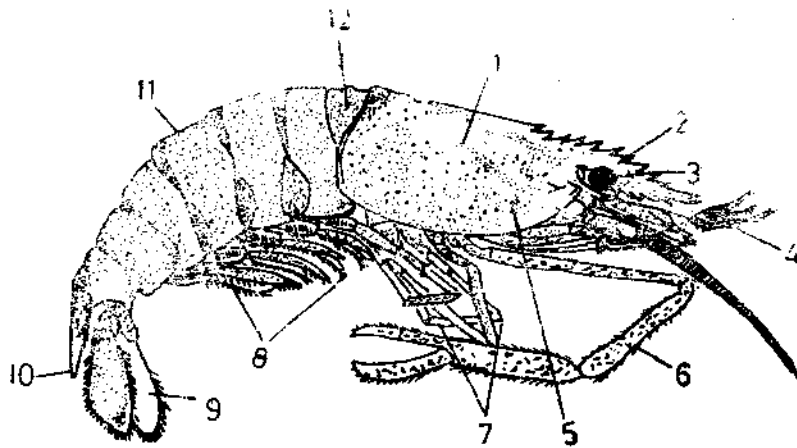

Fig. 18.1. *Palaemon malcolmsoni* — External characters. 1. Cephalothorax. 2. Rostrum 3. Compound eye. 4. Antennule. 5. Carapace. 6. 2nd chelate leg. 7. Non-chelate legs. 8. Pleopods, 9. Uropods. 10. Telson. 11. Abdomen. 12. Arthroial membrane.

The body of adult prawn is divided into two distinct regions:

- i) an anterior rigid cephalothorax, and
- ii) a posterior movable abdomen.

18.3.1 Cephalothorax

It is formed by the fusion of head and thorax. It is rigid, immovable, unjointed, more or less cylindrical in shape. It is actually made up of thirteen segments — five of head and eight of thorax. The head is covered with a dorsal plate. The cephalothorax is covered by a large chitinous shield called the carapace. The dorsal plate and the carapace are completely fused to form a continuous dorsal shield and extend anteriorly as the rostrum which is provided with serrated margins. Laterally the carapace has flaps known as branchiostegites. They protect the gills. A pair of compound eyes are located at the base of the rostrum on movable eye stalks.

18.3.2 Abdomen

The abdomen consists of six movable segments and a terminal conical piece, called the telson. The abdomen is usually turned downwards. Each segment of the abdomen has a pair of jointed appendages called pleopods or swimmerets.

18.4 EXOSKELETON

The entire body including the appendages is covered by an exoskeleton. It is a chitinous cuticle. It is hardened by deposits of calcium salts. The cuticle is thin and soft at the joints to allow free movement. Between the segments there is a thin membrane, the **arthrodial membrane**. Movement is made possible because of this membrane. Typically the exoskeleton of an abdominal segment is composed of a dorsal convex piece the **tergum**. The narrow ventral plate is the **sternum**. The thin lateral downward prolongation of the tergum on each side is called the **pleuron**. The appendages are attached to the sternum of each segment. The part between the appendage and the pleuron of that side is known as the **epimeron**.

APPENDAGES

The appendages in prawn arise at the ventrolateral margin of each segment. There are altogether nineteen pairs of appendages—cephalic five pairs, thoracic eight pairs and abdominal six pairs.

Structure of typical appendage: The segments of an appendage are known as **podomeres**. The

basal part of the appendage is known as **protopodite**. It consists of two podomeres, the proximal **coxa** and the distal **basis**. Two rami extend from the basis, namely the inner **endopodite** and an outer **exopodite** each made up of many segments. The podomeres are connected through arthrodial membrane. This type of appendage is known as **biramous appendage**.

18.5.1 Cephalic Appendages

These are 5 pairs — (i) antennules, (ii) antennae (iii) mandibles (iv) maxillulae and (v) maxillae. Of these antennules and antennae are known as the preoral appendages. Mandibles, maxillulae and maxillae are known as post oral appendages (Fig. 18.2).

(i) **Antennules** (first antennae) These lie at the bases of the eye stalks. They have a protopodite of 3 podomeres. The basal podomere is the precoxa followed by coxa and basis. The basis bears two flagellae known as the outer and inner feelers. The outer feeler is divided into two. The precoxa bears a sense organ, the **statocyst**, an organ of balance. The antennules are thought to be uniramous. The flagellae do not seem to represent the endopodite and exopodite. Antennules are **tactile and balancing** in function.

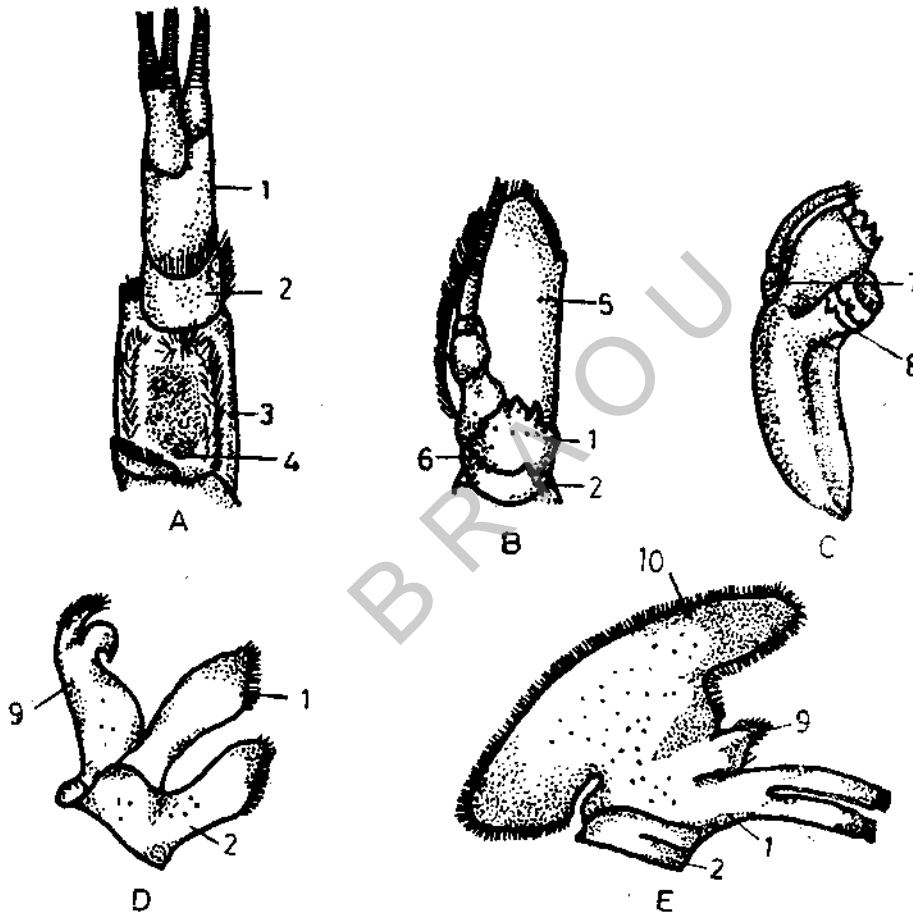

Fig. 18.2. *Palaemon* — Cephalic appendages. A. Antennule B. Antenna. C. Mandible. D. First maxilla. E. Second maxilla. 1. Basis 2. Coxa 3. Precoxa. 4. Statocyst. 5. Squama. 6. Renal aperture. 7. Palp. 8. Molar process 9. Endopodite. 10. Exopodite.

(ii) **Antennae** (second antennae): They are situated immediately below and behind the antennules. The protopodite has two segments. The endopodite is a long many-jointed filament. The exopodite is modified into a broad plate called the **squama**. Coxa bears a renal aperture. Antennae are **tactile and excretory** in function.

(iii) **Mandibles**: They lie one on either side of the mouth. Each mandible has a strongly calcified basal part. The inner edge is toothed. This is the protopodite. A short two jointed process known as the **palp** represents the endopodite. Exopodite is absent. Mandibles help in **mastication**.

(iv) **First maxillae or maxillulae:** They are very small in size. The protopodite consists of two, flattened leaf-like lobes. They project inwards as jaws, also known as gnathobases. They are covered with setose hairs. The endopodite is slender and two-jointed. Exopodite is absent. The maxillae help in pushing the food into the mouth.

(v) **Second maxillae:** The protopodite is flat. It is cut up into four leaflike lobes forming gnathobases. Endopodite is small and unsegmented. The exopodite is broad and forms an expanded plate-like structure called the scaphognathite. The border has plumose hairs. Maxillae have both feeding and respiratory function.

18.5.2 Thoracic Appendages

The anterior three pairs of thoracic appendages form maxillipedes or foot jaws (Gr. maxilla : jaw; pedos. feet), The succeeding five pairs form the walking legs or pereopods. (Fig. 18.3)

(i) **First maxillipede:** The protopodites are flat and divided incompletely into three lobes. The lobes are fringed with setose hairs. The endopodite and exopodite are also flat lobes. They help in feeding and also in tactile function.

(ii) **Second maxillipede:** The protopodite have two segments. The endopodite is bent with five podomeres. They are **ischium, merus, carpus, propodus** and **dactylus**. Exopodite is long and slender. Setae are present. A small epipodite and a gill are present on the outer border. These help in feeding as well as in respiration.

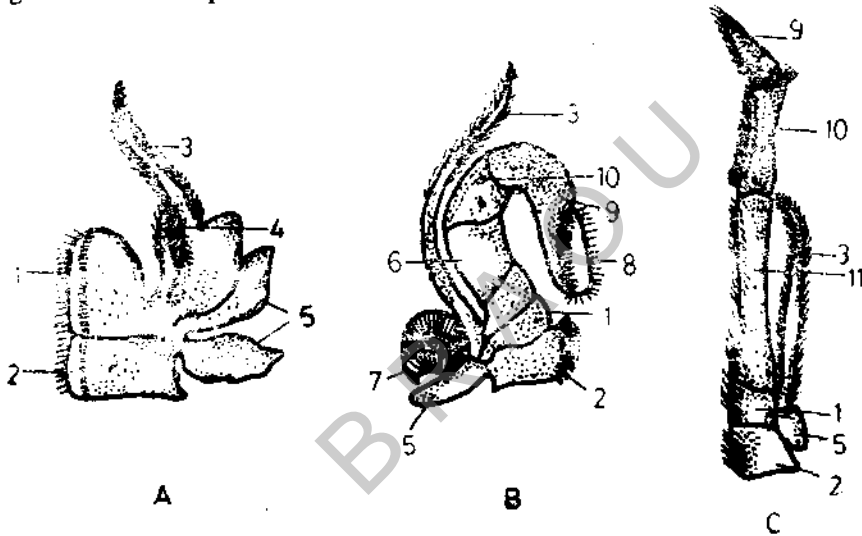

Fig. 18.3 Palaemon - Thoracic appendages A. First maxillipede. B. Second maxillipede. C. Third maxillipede. 1. Basis 2. Coxa. 3. Exopodite. 4. Endopodite. 5. Merus 6. Gill. 7. Dactylus. 8. Propodus. 9. Carpus. 10. Ischium - Merus.

(iii) **Third maxillipedes:** These are leg like. Protopodite consists of two lobes. Coxa is short and bears the epipodite. Endopodite is three-segmented, and a cylindrical basis. The two rami arise from the basis. The inner ramus is the endopodite while the outer is the exopodite. The endopodite gives off from the inner side a short, slightly curved rod — the appendix interna. It has a knob-like head. Setae are present on the outer surface of basis and the margins of endopodite.

First pair of pleopods: In this the endopodite is reduced and the appendix interna is absent.

Second pair of pleopods: There is an additional rod-like appendix masculina in between endopodite and appendix interna in males.

In female, appendix internae of opposite appendages join together, forming a series of bridges. They help to carry the eggs.

Sixth pair of abdominal appendages or uropods: These are broad, flat plates situated on either side of the telson. Protopodite is modified into a broad plate or **sympod**. Endopodite is flat and oval

with setae. Exopodite is large. It is divided into two parts by a transverse suture.

18.6 DIGESTIVE SYSTEM

The digestive system of prawn consists of alimentary canal and digestive gland (Fig. 18.5). The alimentary canal consists of three distinct parts:

- i) Foregut or stomodaeum.
- ii) Midgut or mesenteron.
- iii) Hindgut or proctodaeum.

Foregut Foregut is lined by the ectoderm and cuticle. **Midgut** is lined internally by the true endodermal cells and **proctodaeum** is also lined by the ectoderm and cuticle.

The foregut or stomodaeum has three distinct regions.

- (i) Buccal cavity (ii) Oesophagus (iii) Stomach.

The **mouth** lies on the ventral side of the head. It is bounded by labrum in front, bilobed labium behind and laterally by the mandibles. The mouth leads into a short **buccal cavity**. It is provided with a thick chitinous irregularly folded internal lining. Following the buccal cavity is the **oesophagus**. It runs vertically upwards into the **stomach**. The inner wall is muscular and is covered with various bristles. The opening of the oesophagus into the stomach is provided with a valve-like chamber. It occupies most of the cephalothorax. It consists of two parts — the **cardiac stomach** and the **pyloric stomach**.

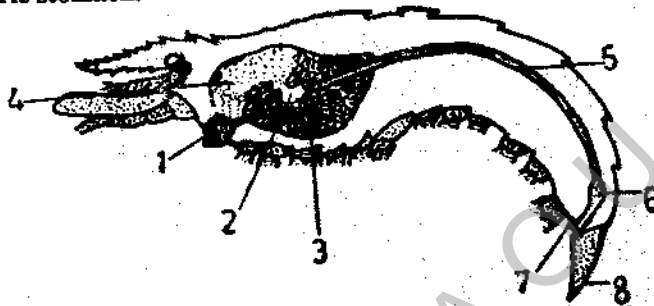

Fig. 18.5. *Palaemon* — Digestive system. 1. Mouth. 2. Pyloric stomach. 3. Hepatic caeca. 4. Cardiac stomach. 5. Mesenteron. 6. Rectum. 7. Anus. 8. Telson.

The anterior wall of the oesophageal opening is covered by thin circular cuticular plate. A lanceolate plate is present on the anterior part of the roof. The inner lining of the cardiac stomach is thrown into longitudinal folds. In certain places it is thickened and calcified to form plates and rods. There is a triangular plate on the floor of the cardiac stomach. This extends throughout the length in the middle. It is known as the **hastate plate**. On either side of this triangular plate there is a ridged plate called the **comb plate**. It is fringed with closely set bristles to form comb-like structures. There is a longitudinal ridge on either side of the combed plate known as the **guiding ridge** (Fig. 18.6)

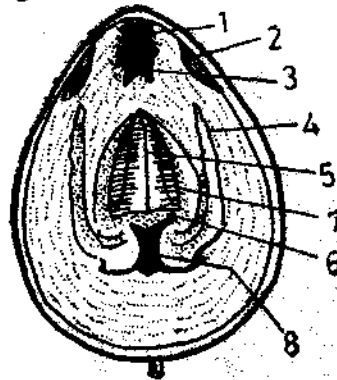

Fig. 18.6 *Palaemon* — Dorsal view of floor of cardiac stomach. 1. Circular cuticular plate. 2. Lanceolate plate. 3. Oesophageal opening. 4. Longitudinal fold. 5. Hastate plate. 6. Anterior valve 7. Comb plate. 8. Cardio-pyloric aperture.

The posterior border of the hastate plate has a thick growth of delicate setae. It forms the anterior valve of cardiopyloric aperture.

Cardiac stomach opens into the pyloric stomach by X-shaped cardiopyloric aperture. The opening is guarded by four valves. These valves make the cardiopyloric aperture act as a sieve. It allows food material in a fine state to pass into the pyloric stomach.

Pyloric stomach is a short, narrow chamber. It is situated below the posterior end of the cardiac stomach. Its lateral walls are thick and muscular. They project into the lumen of the pyloric stomach as thick, longitudinal folds. These folds divide the lumen into a dorsal and a ventral chamber. These two chambers are connected by a narrow vertical canal. The floor of the ventral chamber is elevated into a median longitudinal ridge. This ridge forms two lateral compartments. The floor is provided with an A-shaped filter plate or pyloric filter. The filter bears longitudinal ridges having bristles and grooves. Thus an efficient filter or sieve or strainer is formed. Only liquid food is allowed to pass through it. A pair of small openings are located just behind the pyloric filter. These are the openings of the hepatopancreatic duct. Digestive juices are poured through these openings into the pyloric stomach.

Midgut: It is a long narrow, slender tube. It extends as far as the sixth abdominal segment. Its lumen is lined by an epithelium formed by endodermal cells. It is thrown into many longitudinal folds. It opens into the hindgut.

Hindgut: It is a short portion. It is lined internally by the cuticle. Its front part is swollen as the rectum. It opens to the exterior by the anus ventrally at the base of the telson.

Hepatopancreas: It is also called the liver or digestive gland. It is situated behind the cardiac stomach and also partly over laps it. It is usually orange-red in colour. Each lobe consists of numerous minute tubules. These tubules are connected with canals which finally form the hepatopancreatic duct. The two hepatopancreatic ducts open separately into the ventral chamber of the pyloric stomach.

Palaemon feeds on mosses, algae and other weeds. The maxillulae, maxillae and maxillipedes help in directing the food into the mouth. Mandibles masticate the food into small bits.

Physiology of Digestion

The smaller particles of the food from the cardiac stomach are passed on to the pyloric stomach. The secretions of the hepatopancreas is poured into the pyloric stomach. Secretions reach the cardiac stomach and mix with the food. By the contraction and relaxation of cardiac stomach food is churned. The food in the semi-liquid and semidigested form is carried into the ventral chamber. This is filtered here by the pyloric filter. The digested food then enters the hepatopancreas through the hepatopancreatic ducts. Absorption takes place in the hepatopancreas. Thus hepatopancreas serves for digestion as well as for absorption. The residual food enters the midgut. Some more absorption takes place here. The undigested wastes pass on to the hindgut and finally thrown out through the anus.

18.7 RESPIRATORY SYSTEM

In the fresh water prawn the respiratory organs are well developed (Fig. 19.7). These consist of the following structures:

- i) Branchiostegite or gill cover.
- ii) Three pairs of epipodites.
- iii) Eight pairs of gills or branchiae.

Branchiostegite: Each gill chamber is enclosed between the branchiostegites and the thoracic wall. The inner linings of the branchiostegites are thin, membranous and highly vascular containing blood lacunae. These are constantly bathed in water. Oxygen dissolved in water is exchanged for CO_2 in the blood lacunae.

Epipodites: There are three pairs of simple, leaf-like highly vascular epipodites. These are projections of the coxal podomeres of the three maxillipedes. They are richly supplied by blood vessels. Gaseous exchange takes place through them.

Gills: There are eight pairs of branchiae or gills. These are situated in the gill chamber enclosed by the gill covers.

Gills are named according to their place of origin and attachment. There are three kinds of gills.

i) **Podobranch** (or foot gills): It is found attached to the coxa of an appendage. e.g. second maxillipede.

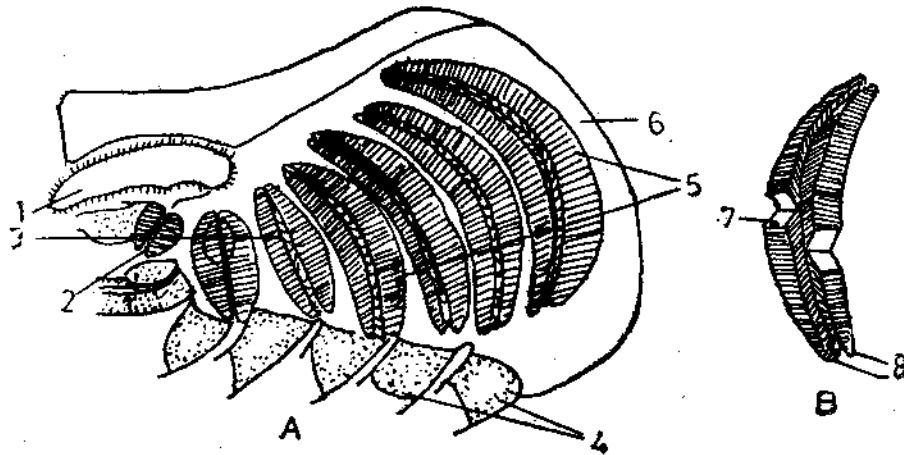

Fig. 18.7. *Palaemon*. A. Branchial chamber with gills. B. Phyllobranch. 1. Scaphognathite. 2. Podobranch. 3. Arthrobranch. 4. Walking legs. 5. Pleuro branches. 6. Gill chamber. 7. Gill plates. 8. Two rows of gill plates.

ii) **Arthrobranch** (or joint gill): It is found attached to the arthrodistal membrane joining an appendage to the thorax. e.g., arthrodistal membrane of the third maxillipede.

iii) **Pleurobranch** (or side gill): It is found attached to the lateral wall of the segment having appendages. e.g., Five pleurobranches attached to the five walking legs.

Structure of a gill: Each gill is crescentic in shape. The gills in the anterior end are smaller in size. The gills towards the posterior end gradually increase in size. Gills are richly supplied with blood vessels (Fig. 19.7 B).

All the gills of prawn consist of two rows of thin, leaf-like gill plates. The gill plates are arranged closely like the leaves of a book. This type of gill is called a phyllobranch. In *Palaemon* all the eight pairs of gills are phyllobranches. Gill plates are arranged at right angles to the long axis or base of the gills. These are largest in the middle but are gradually smaller towards the two ends. There is a median longitudinal groove between the two rows of gill plates.

Mechanism of Respiration: A current of water is created in the gill chamber by the constant vibrations of the scaphognathite of the maxillae. The water flows over the gills and epipodites. Gaseous exchange takes place. Oxygen dissolved in water is taken into the blood and CO_2 given out. The blood contains the respiratory pigment haemocyanin.

18.8 BLOOD VASCULAR SYSTEM

The colour of the blood in *Palaemon* is fairly bluish. The blue colour is due to the copper containing respiratory pigment, the **haemocyanin**. The blood is thin, watery. It contains amoebocytes.

In prawn the vascular system is of the open type. It includes i) pericardium ii) heart iii) arteries iv) sinuses or blood lacunae and v) blood channels.

Pericardium: It is a wide space found just below the dorsal thoracic wall surrounding the heart. A thin, horizontal pericardial septum forms the floor of pericardium. It is attached to the body wall. The pericardium is incompletely filled with blood coming from the channels. From pericardium the blood passes into the heart.

Heart: It is a muscular structure. It is enclosed in the pericardium. The heart is kept in position inside the pericardium by strands known as cardiopyloric strands and lateral strands. Five pairs of ostia are present in the heart. Blood from the pericardial sinus enters the heart through these ostia. Valves are present in the ostia to allow blood to flow only in one direction.

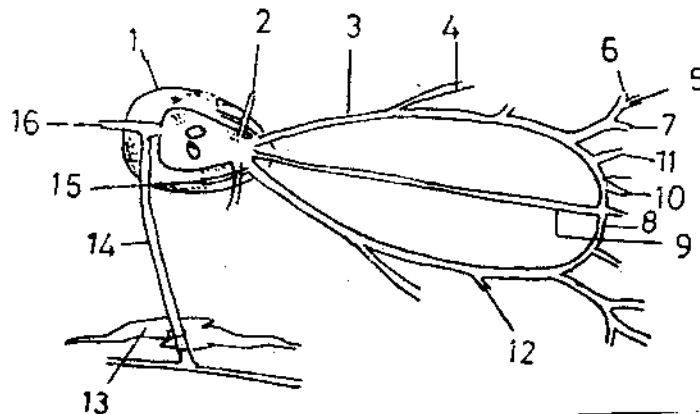

Fig. 18.8. *Palaemon* — Main blood vessels (Arteries) 1. Heart. 2. Hepatopancreatic. 3. Antennary. 4. Gastric. 5. Renal. 6. Antennal. 7. Antennular. 8. Circular cephalicus. 9. Median ophthalmic. 10. Rostral. 11. Optic. 12. Mandibular. 13. Thoracic ganglion. 14. Sternal. 15. Pericardial. 16. Supra intestinal.

Arteries: Arteries are given out in the anterior region as well as in the posterior region. The three anterior arteries are median ophthalmic artery and paired antennary arteries. (Fig. 18.8) The two antennary arteries of the right and left and the ophthalmic artery unite in front to form circular cephalicus. The antennary arteries also give out branches to various organs such as antennules, antennae, eyes etc. From the antennary artery branches are also given off to the hepatopancreas (hepatic artery), the stomach (gastric artery) and the muscles of the mandibles (mandibular artery). Posteriorly a single artery arises from the heart which divides into two branches - i) Supraintestinal artery and ii) the sternal artery. The supraintestinal artery supplies the intestine and the dorsal muscles of the abdomen. The sternal artery divides into two branches, the ventral thoracic artery and a posterior abdominal artery. The thoracic arteries supply blood to the sternal region of the thorax, the mandibles, the maxillae, the maxillipedes and the first three pairs of walking legs. The posterior abdominal artery supplies the ventral region of the abdomen.

Mechanism of Circulation: The arteries carrying blood from the heart open into haemocoelic space bathing the organs with blood. The blood is collected into sinuses and from there taken to the gills through six afferent branchial channels. In the gills the blood is oxygenated and sent into the pericardial sinus through the efferent branchial channel. From the pericardial sinus the blood enters into the heart through the ostia. When the heart contracts the blood is again pumped into the arteries.

Excretory Organs

In *Palaemon* excretory organs consist of **antennary** or green glands. These lie enclosed within the coxal segment of each antenna. Each gland is an opaque-white structure of the size of a pea. It consists of three parts. i) end sac ii) labyrinth or glandular plexus and iii) bladder (Fig. 18.9 A).

i) **End sac:** The end sac is a small bean-shaped structure lying in the anterior part of the gland internal to the labyrinth. The wall of the end sac is produced into a number of radial septa. These septa project into the cavity of the end-sac. The cavity communicates with the labyrinth by a single aperture. The wall of the end sac consists of two layers - the outer thick layer of connective tissue and an inner thin layer of large excretory epithelial cells.

ii) **Labyrinth:** The labyrinth is larger than the end sac. It consists of a mass of highly convoluted and branching excretory tubules. The tubules open into the end sac by a common opening. The other end opens into the bladder by several openings. The wall of each tubule consists of a single layer of excretory epithelial cells.

iii) **Bladder:** The urinary bladder is a thin-walled sac lying on the inner side of the end sac. Its

inner wall from a short excretory duct of ureter. It opens outside by a small rounded renal or excretory aperture on the coxa of the antennae.

Lateral ducts: A narrow duct is formed from each anteanary gland. It runs posteriorly as the internal duct. The two lateral ducts of both the sides are connected by a transverse connective. The lateral ducts open into an elongated renal sac.

Renal sac: It is a large median elongated, thin-walled sac situated above the cardiac stomach and below the carapace. Its wall consists of a single layer of flattened epithelial cells.

Physiology of green gland: The labyrinth is profusely supplied with blood by the antennary artery. The antennary glands carry on two important functions. i) Removal of nitrogenous wastes and ii) Osmoregulation.

The end sac performs the function of removal of ammonia. The uric acid and related nitrogenous wastes are removed by the other parts. The excretory fluids are first collected in the urinary bladder. These are then expelled outside through the renal apertures.

The integument also collects a few wastes. These are discharged when the exoskeleton is cast off at each moult or ecdysis.

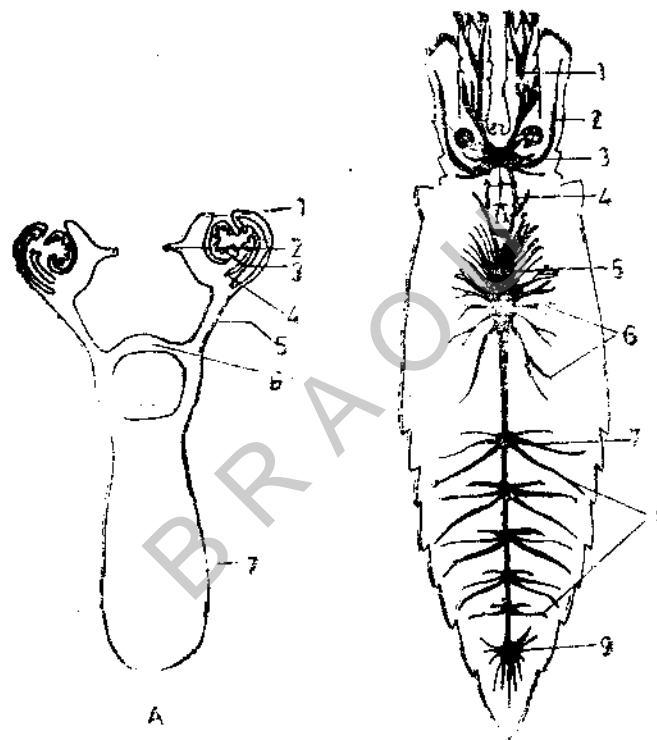

Fig. 18.9. *Palaemon*. A. Excretory organ. 1. Urinary bladder. 2. Renal pore. 3. End sac. 4. Labyrinth. 5. Lateral duct. 6. Transverse connective. 7. Renal sac. B. Nervous system. 1. Antennular nerve. 2. Antennary nerve. 3. Brain. 4. Circumoesophageal connective. 5. Thoracic ganglion. 6. Nerves to walking leg. 7. First abdominal ganglia. 8. Nerves to pleopods and muscles. 9. Sixth abdominal ganglion.

18.10 NERVOUS SYSTEM

The nervous system consists of i) central nervous system ii) peripheral nervous system and iii) sympathetic nervous system. (Fig. 18.9 B).

Central nervous system: It consists of a number of ganglia joined by connectives. The brain or cerebral ganglia or supraoesophageal ganglia is a bilobed structure. It is situated at the base of the rostrum anterior to the oesophagus. Nerves are distributed from the brain to eyes, antennules antennae, labrum etc.

The two nerve cords arise from the posterior part of the brain. They run backwards and downwards around the oesophagus. They unite ventrally with the suboesophageal ganglion. In prawns the suboesophageal ganglion is not distinctly seen because of the massive thoracic ganglia. The two circumoesophageal connectives are connected by a very delicate transverse connective near the posterior end.

The thoracic ganglionic mass is an elongated mass of nervous matter. It is formed as a result of the fusion of eleven pairs of ganglia. It gives off nerves to mandibles, maxillulae, maxillae, all the maxillipedes and all walking legs. There is an opening in the thoracic ganglion for the passage of the sternal artery.

The thoracic ganglionic mass continues posteriorly with the ventral nerve cord. It is actually double and consists of six abdominal ganglia. Each abdominal segment has an abdominal ganglion and three pairs of nerves are distributed to the pleopods and muscles. The sixth ganglion is large and gives off six pairs of nerves. These innervate uropods, telson and other parts of the posterior region.

18.10.1 Sense Organs

The sense organs of prawn are i) a pair of compound eyes ii) statocysts and iii) tactile organs.

Compound Eyes

There is a pair of compound eyes. Each eye is situated on a short, movable and two-segmented stalk, in between bases of antennules and the rostrum in an orbital notch. It is a composite structure. It consists of a large number of individual units termed ommatidia or ocelli. This type of eye is characteristic of the arthropods.

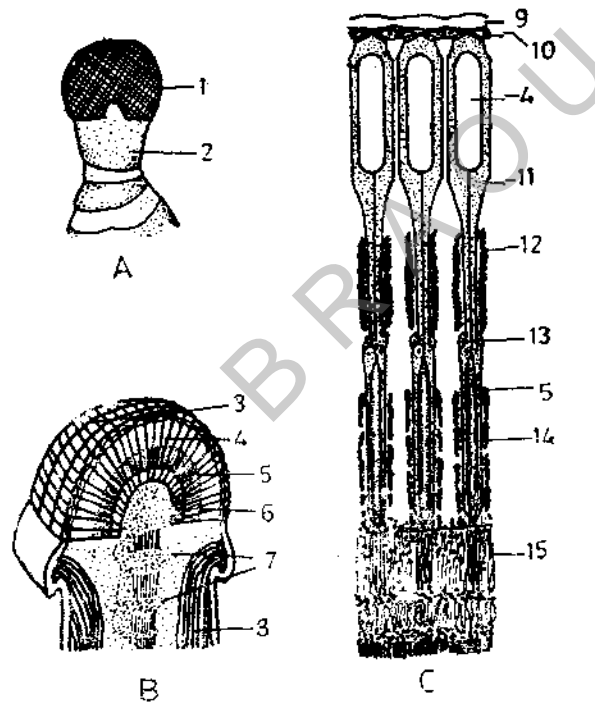

Fig. 18.10 Palaemon A. Stalked compound eye. B. Diagrammatic L.S. of compound eye. C. Ommatidia (diagrammatic longitudinal section) 1. Eye 2. Two jointed stalk. 3. Facets. 4. Crystalline cone. 5. Rhabdome. 6. Nerve fibres. 7. Optic ganglia 8. Muscles 9. Cornea 10. Comeagen cell. 11. Cone cell. 12. Iris ligament 13. Retinal cell. 14. Retinal pigment 15. Basal membrane.

Microscopic structure of the compound eye

The outermost layer of the eye is the cornea. It is the transparent cuticle. The cornea is made up of large number of squarish or rectangular facets. An **Ommatidium** is present below each facet. The Ommatidium consists of the following parts:

1. Each corneal facet thickens in the centre to form a biconvex corneal lens.
2. The lens is secreted by two flat cells called the **corneagen cells**. The paired corneagen cells are of epidermal origin. They secrete a new corneal layer after ecdysis.
3. Four elongated cone cells or **vitellae** are situated below the corneagen cells. The cone cells are broader outside. The inner ends of the cone cells are long and tapering.
4. The cone cells secrete and surround a transparent homogeneous crystal line cone.
5. The part of the ommatidium from the cornea upto the inner ends of cone cells is known as the **dioptrical region**.
6. The dioptrical region is concerned only with the focussing of light on the underlying region. This region is known as **receptor or retinal region**.
7. An elongated, spindle-shaped, transversely striated structure lies below the cone cells. It is known as rhabdome.
8. It is surrounded by seven elongated retinular cells. These cells secrete and nourish the rhabdome.
9. The rhabdome and the retinular cells together form the receptor or retinal region of the ommatidium.
10. The inner ends of the rhabdomes rest upon the basal membrane. They are continued with nerve fibres of the optic ganglion. The optic ganglion is connected with the brain by the optic nerve.
11. Each ommatidium is separated from its neighbouring ommatidia by pigment sheath. The sheath is known as the **retinal pigment**. The distal pigment is known as the **iris pigment**. Retinal pigment surrounds the rhabdome. The iris pigment surrounds the crystalline cone.

Working of the Compound eye: The working of this eye is very complex. Light enters through all of the ommatidia. Each ommatidium is capable of producing a separate image of a small part of the object in vision. Therefore, the image so formed is due to the combined effect of all the ommatidia. Thus the vision effected through a compound eye is termed **mosaic vision**.

In nocturnal forms like *Palaemon* the image formed is superposition image. i.e. the image seen by the eye is formed by overlapping points of light. It is adapted for seeing in weak light. In **diurnal crustaceans** the compound eyes produce apposition or mosaic image.

ii) Statocysts These are a pair of small, white, cuticular, hollow, flask-shaped structures. (Fig. 18.11 A) Each statocyst is situated in the precoxa of the antennule attached to its dorsal wall. It consists of a sac lined with sensory hairs and a cavity filled with sand grains. The sand grains are the statoliths. The statocyst is innervated with a small statocystic branch of antennular nerve. The function of the statocyst is to maintain balance and position.

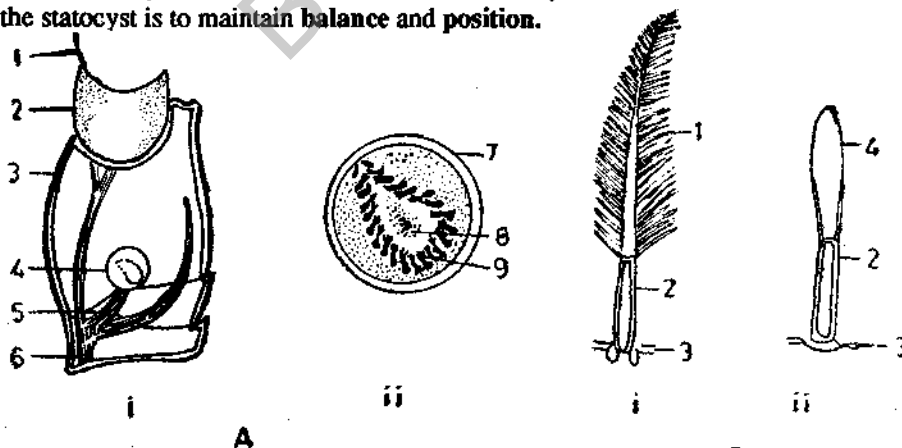

Fig. 18.11 *Palaemon*. A. Statocyst (i. In situ; ii. T.S. of statocyst). 1. Basis. 2. Coxa. 3. Precoxa. 4. Statocyst. 5. Statocystic nerve. 6. Antennular nerve. 7. Cuticle. 8. Otoliths. 9. Sensory setae. B. Sensory structures (i. Tactile setae; ii. Olfactory setae). 1. Barbs. 2. Shaft. 3. Cuticle. 4. Blade.

iii) Tactile organs:

These are situated on the elongated **flagella** of the antennae and other parts of the body such as the

appendages. A tactile setae consist of a swollen base or shaft and a tip or blade. Each tactile organ is supplied with a nerve fibre. (Fig. 18.11 B)

Olfactory setae: These are found on the small, middle feeler of the antennule. These also contain a shaft and a blade. Nerve fibres of the antennular nerve supply these setae. The function of these setae is olfactory.

18.11 REPRODUCTIVE SYSTEM

Palaemon is dioecious. They exhibit sexual dimorphism. In males the second pair of chelate legs are very long. They have a thick covering of spines and setae. In male the genital openings are situated on the arthroal membrane between 5th leg and thorax. In the females the genital openings are situated on the coxa of the third walking legs.

Male reproductive organs: These consists of a pair of testes, a pair of vasa deferentia, a pair of vesicula seminalis, male genital openings. (Fig. 18.12 A).

Testes are soft, white, elongated structures below the heart and above the hepatopancreas. Anteriorly the testes fuse together to form a common lobe. Posteriorly they are separate. A long tightly coiled tube arises from the posterior end of each testis. It is **vas deferens**. It runs downwards posteriorly to open at the junctions of thorax and the fifth walking leg. Before opening outside each vas deferens swells into a sac-like structure called the seminal vesicle or vesicula seminis. Here the sperms are stored in the form of spermatophores.

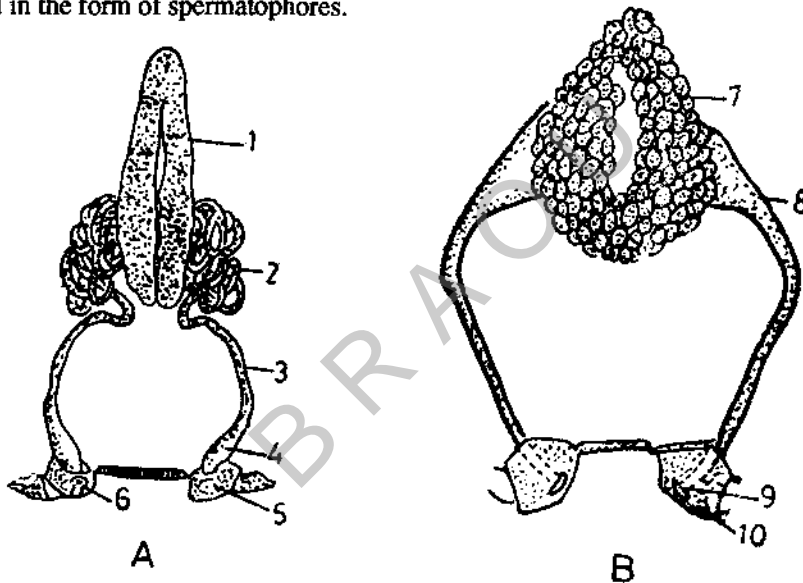

Fig. 18.12. *Palaemon*. A. Male reproductive system. 1. Testis. 2. Coiled portion of the vas deferens. 3. Vas deferens. 4. Seminal vesicle. 5. Coxa of the 5th walking leg. 6. Male genital aperture. B. Female reproductive system. 7. Ovary. 8. Oviduct. 9. Female genital aperture. 10. Coxa of the 3rd walking leg.

Female reproductive organs They consist of a pair of ovaries, a pair of oviducts and female genital openings. (Fig. 18.12 B).

Ovaries are white, compact, sickle-shaped structures. Both the ends of the ovaries are fused with a gap in the middle. However, the size and shape changes with the age and reproductive stage of the animal. Oviducts are a pair of short broad and thin-walled tubes. They run vertically, downwards to open on the coxa of third walking legs.

Breeding season in *Palaemon* is between May and July. Fertilization is external. The female lays a large number of eggs. After fertilization eggs get attached to the setae on the pleopods. Development in *Palaemon* is direct, without any larval stage. In *Penaeus* (marine prawn) on the other hand, development is indirect. It involves a series of larval forms such as *nauplius*, *protozoa*, *zoea* and *mysis* before metamorphosing into the adult.

Check Your Progress

1. Distinguish various appendages of prawn. The basic plan underlying all appendages consisting of Podomeres, namely the , and
2. Hepatopancreas secretes digestive enzymes containing, and
3. Regardless of a well-developed pulsating, heart and artereis in prawn, the blood is emptied into from where again it enters heart.

18.12 SUMMARY

Palaemon is the freshwater prawn — a representative of class Crustacea.

The head and thorax are fused to form a cephalothorax.

Appendages of the biramous type are present in pairs in each of the segments.

Stomach has cuticular thickenings forming plates and valves.

Hepatopancreas is the digestive gland.

Gills are respiratory organs.

Blood vascular system open type, blood filling the perivisceral space.

Antennary or green glands are excretory organs.

A pair of compound eyes are located on movable eye stalks.

Sexes are separate. Sexual dimorphism is distinct.

Development direct.

18.13 CHECK YOUR PROGRESS - MODEL ANSWERS

1. Protopodite, endopodite, exopodite
2. Proteases, lipases.
3. Sinuses

18.14 MODEL EXAMINATION QUESTIONS

I. Answer the following questions in about 30 lines

1. Describe briefly the various appendages of prawn.
2. Describe the digestive system of *Palaemon*. Add a note on the physiology of digestion.
3. Describe the process of respiration in prawn.
4. Describe the blood vascular system of prawn.
5. Describe the structure of compound eye of prawn. Add a note on working of the compound eye.
6. Describe the male and female reproductive organs of prawn.

II. Answer the following questions in about 10 lines

1. Describe the structure of a gill in prawn.
2. Describe the structure of green gland. Add a note on its physiology.

UNIT-19 GENERAL CHARACTERS AND AFFINITIES OF ONYCHOPHORA

Contents:

- 19.1 Objectives
- 19.2 Introduction
- 19.3 External Structure
- 19.4 Internal Anatomy
- 19.5 Geographical Distribution
- 19.6 Affinities of Peripatus
 - 19.6.1 Annelidan characteristics
 - 19.6.2 Arthropodan characteristics
 - 19.6.3 Onychophoran characteristics
 - 19.6.4 Molluscan characteristics
- 19.7 Taxonomic Position
- 19.8 Summary
- 19.9 Check Your Progress — Model Answers
- 19.10 Model Examination Questions

19.1 OBJECTIVES

In this unit an animal which combines characters of two different phyla is described and the relationship and taxonomic position of the animal is discussed. At the end you will be in a position to explain the interesting dual features present in the group which keep the zoologists in puzzle with regards to its position in Animal Kingdom.

19.2 INTRODUCTION

Class *Onychophora* includes terrestrial arthropods. The onychophorans have been described as missing links between annelids and arthropods. These arthropods have the general body form of annelids. An exoskeleton which is characteristic in arthropoda is absent in these animals. Instead these have a cuticle which is soft and velvety to touch. The body wall has layers of circular and longitudinal muscles. Jointed appendages are absent. However, numerous short, unjointed, clawed appendages occur in pairs. Cilia line the coelomoducts. Development is direct. The class *Onychophora* originally thought to be monotypic was represented by a single genus *Peripatus*. But now the species are included under twelve genera in two families.

19.3 EXTERNAL STRUCTURE

Onychophorans (Fig. 19.1) are cylindrical, caterpillar-like forms. These look very much like slugs with legs; hence were mistaken for *molluscs* by *Guilding* who first discovered them in 1825. The body of *Peripatus* is not divided into segments. It has a fairly well marked head. It is 1.4 dm to 15 cm in length. The entire surface of the body is thrown into a number of fine transverse wrinkles. The integument is beset with numerous conical papillae. Each conical papillae is capped with a small chitinous spine. The head bears a pair of antennae, a pair of eyes, a pair of jaws and a pair of short processes known as the oral papillae. The antennae are made up of a number of rings which bear minute spines. There is a small eye at the base of each antennae. The mouth is ventral in position. A short, conical oral papilla is present on either side of the mouth. Openings of the slime glands are located on the surface of the oral papilla. A pair of mandibles lies at the sides of the mouth enclosed by a circular lip. The oral papillae and the mandibles have developed as modified appendages. The legs vary in number from 14 to 43 pairs depending upon the species and the sex. Each leg is a large, conical, unjointed protuberance bearing a pair of terminal claws. Three to six

transverse pads are present ventrally at the tip of the leg or the foot. The leg rests on these pads while walking.

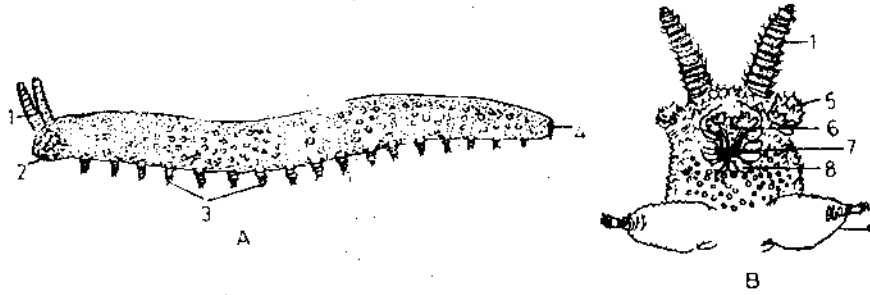

Fig. 19.1 Peripatus. A. External characters. B. Ventral view of anterior end. 1. Antenna. 2. Mouth. 3. Legs. 4. Anus. 5. Oral papillae. 6. Tongue. 7. Mandibles. 8. Lobes of the buccal region. 9. First pair of legs.

Onychophorans are coloured blue, green orange or black. The papillae give the body surface a velvety and iridescent appearance.

19.4 INTERNAL ANATOMY

The body wall consists of a cuticle which is thin, flexible and very permeable (Fig. 19.2). Beneath the cuticle there is a single layer of epidermis. A thin dermis and three layers of muscle fibres lie next to the epidermis. The muscle fibres are circular, longitudinal and diagonal. The body wall is thus dermomuscular - typical of annelids. The body cavity is divided into a median and two lateral compartments by incomplete muscular partitions. The coelom is reduced to the gonadial cavities and to small sacs associated with the nephridia. The body cavity is a haemocoel.

Peripatus crawls by means of the legs and by extension and contraction of the body which is held off the ground. Waves of contraction progress from the anterior to the posterior. Locomotion is slow.

The onychophorans have a pair of glands which open at the tips of oral papillae. These are **slime or adhesive glands**. They are believed to be modified coxal glands. When disturbed they discharge a substance as two streams for a distance of about 50 cm. On being exposed to air it hardens very rapidly.

The **digestive system** consists of mouth, buccal cavity, pharynx, oesophagus, mesenteron or midgut, rectum and anus and a pair of salivary glands.

The mouth is located ventrally in between the oral papillae. The mouth is surrounded by a circular lip. It encloses the claw-like mandibles or jaws which are used for grasping and cutting the prey. The buccal cavity is small and is formed by the union of some of the conical papillae. It is followed by a thick-walled pharynx. It leads into a narrow oesophagus. The mouth, buccal cavity, pharynx and oesophagus are lined by chitin. They constitute the **foregut** or the **stomodaeum**. The oesophagus leads into the **mesenteron** or **midgut**. The midgut is a wide somewhat thin-walled, non-chitinous tube which extends nearly to the posterior end of the body. The rectum is narrow tubular and loops forward over the mesenteron. It opens outside by the anus situated on the last body segment. The rectum is lined by chitin and is known as the **hindgut** or **proctodaeum**. Stomodaeum and proctodaeum are lined by ectoderm while the mesenteron or midgut is lined by endoderm. Salivary glands, which are modified nephridia are a pair of long, narrow, tubular glands. They are located in the lateral compartments of the coelom and open into the pharynx.

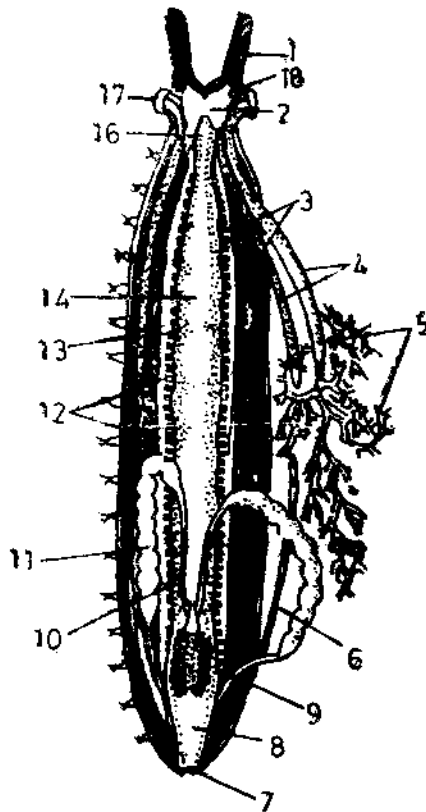

Fig. 19.2 *Peripatus* - Internal anatomy. 1. Nerve to antenna. 2. Brain 3. Excretory organs. 4. Salivary gland. 5. Slime gland. 6. Coxal gland. 7. Anus. 8. Rectum. 9. Ovary. 10. Oviduct. 11. Uterus. 12. Transverse commissures. 13. Lateral longitudinal nerve cord. 14. Stomach - intestine. 15. Oesophagus. 16. Pharynx. 17. Oral papilla. 18. Eye.

Onychophorans are predaceous and feed on small invertebrates such as snails, insects and worms. A number of species display a particular preference for termites.

The **circulatory system** is similar to that of the arthropods. The **heart** is lodged within the pericardial sinus. It is an elongated tube running nearly the entire length of the tube. It is open anteriorly and closed posteriorly. It has a number of pairs of ostia arranged laterally in each segment. Ostia are valvular, closed blood vessels are absent in *Peripatus*. Blood from haemocoel flows into the pericardial sinus through the pericardial openings and from their into the heart through the ostia. The blood is pushed into the body cavity by the contractions of the tubular heart. The blood flows from posterior to the anterior end. The blood is colourless and contains phagocytic amoebocytes.

The **organs of respiration** are delicate **tracheal tubes** - They are usually unbranched. The walls are lined by a thin chitinous layer which is arranged transversely. Groups of such unbranched (Fig. 19.3) tracheal tubes open in little depressions on the surface of the body. These depressions are called the **tracheal pits**. The minute openings of the tracheal pits are known as the **stigmata** or the **spiracles**.

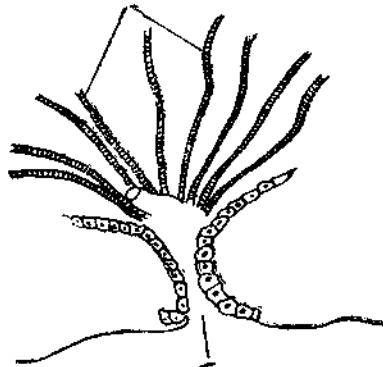

Fig. 19.3 *Peripatus* - A group of trachea with a spiracle. 1. Spiracle. 2. Tracheae

The excretory organs are nephridia. Each segment contains a single pair of nephridia located in the lateral compartments of the body cavity. They open outside on the lower surfaces of the base of the legs. Each nephridium contains a thin-walled closed internal vesicle. The vesicle represents the vestige of the coelom. The vesicle continues into a looped tubule. The tubule in turn opens into a dilated terminal vesicle. The terminal vesicle is a contractile bladder. It opens outside at the bases of the legs by pores called the **nephridiopores**. The nature of the excretory wastes is not known. As described earlier, the anterior nephridia are modified as salivary glands. The posterior nephridia in the female are modified as gonoducts.

A series of pairs of glands lie in the lateral compartments of the body cavity. They are the **coxal or crural glands**. Their ducts open on the lower surface of the legs just outside the nephridiopores. They are thought to have some kind of sexual function.

In addition to the above glands a series of coxal organs are also present. These are thin-walled vesicles. They open outside on the ventral surface of legs. These coxal organs are believed to help in taking up moisture.

The **nervous system** is composed of a large bilobed **brain** located in the dorsal part of the head. Two longitudinal **nerve cords** arise from the brain. They run parallel with one another ventrally extending throughout the length of the body. Behind the anal aperture, the two ends of the nerve cord unite together. The two nerve cords are connected by a number of fine **transverse commissures**. By their arrangement the nervous system takes up the form of a 'ladder'. Nerves are distributed to antennae and eyes from the brain. The two ventral nerve cords contain ganglionic swelling in each segment. Paired nerves are supplied from these ganglionic swellings to leg and body wall.

There is a **small eye** at the base of each antenna. The eye has a large chitinous lens and a well developed retinal layer. Onychophorans avoid light and are mostly nocturnal. The conical papillae and other areas of the integument are supplied with sensory cells.

The sexes are separate. Usually the males are smaller than the females with less number of legs. In the female, there are two tubular **ovaries**, a pair of **oviducts** and two **uteri**. The two uteri are in the form of long curved tubes. They unite behind to form the **median vagina**. The vagina, opens outside on the ventral surface in between the last pair of legs through a genital pore. In some species, a **seminal receptacle** also may be present.

In the male there are a pair of tubular **testes**. Each testis is connected with **vas efferens**. This opens into the **seminal vesicle** by a funnel-like aperture. The **vas deferens** which follows is a long, narrow, coiled tube. The two vasa deferentia unite to form a **median ejaculatory duct**. The ejaculatory duct opens to the outside in the same position as the vagina of the female. The wall of the anterior part of the ejaculatory duct is glandular. It secretes a substance which helps the sperms to form spermatophores.

In forms which lack seminal receptacle, spermatophores reach the ovary in a novel method. The male crawls over the body of the female and deposits a spermatophore on her sides or back. Over a period of time a female may accumulate many spermatophores. The spermatophores stimulate the amoebocytes in the blood. The amoebocytes bring about dissolution of the underlying integument. Sperms then pass into the haemocoel and from there finally reach the ovary. Fertilization of the eggs thus takes place within the ovary. Sperm transfer in Onychophorans with seminal receptacle is not clearly known.

Onychophorans are **oviparous** or **viviparous**. Ovoviviparous condition appears to be more prevalent than the other two methods of development. Development is direct there being no larval stage. The female produces about 30 or more young in a year. The young resembles the adult.

19.5 GEOGRAPHICAL DISTRIBUTION

The geographical distribution of *Peripatus* makes an interesting reading. The group consists of two

families. Each has an extensive **discontinuous distribution**. It is peculiar that neither is found in the same area with species of other family. The family **Peripatidae** is more or less equatorial in distribution. On the other hand **Peripatopsidae** is restricted to the southern hemisphere.

There is a belief that the land masses of the equatorial region and the southern hemisphere were connected during past geological ages. The geological antiquity of Onychophorans spread by other animals in their distribution are evidences in support of this belief.

19.6 AFFINITIES OF PERIPATUS

Peripatus has no economic importance, but it is zoologically very interesting, because it exhibits both arthropod and annelid characteristics as well as peculiarities of its own.

19.6.1 Annelidan characteristics

- i) Worm-like body with truncated ends
- ii) Absence of a true head
- iii) Dermo-muscular body-wall-muscle layers being circular and longitudinal
- iv) Locomotion slow
- v) Structure of the simple eyes as in polychaetes
- vi) Unjointed, hollow, stumpy appendages of the nature of the extensions of the body wall like the parapodia of Polychaeta
- vii) Simple, straight alimentary canal with mouth and anus
- viii) Segmentally arranged paired nephridia
- ix) Slime and coxal glands correspond with similar glands of Chaetopoda
- x) Presence of cilia in the excretory and reproductive ducts.

19.6.2 Arthropodan characteristics

- i) Presence of antennae
- ii) Jaws are modified appendages provided with striped muscles
- iii) Locomotion by definite legs, having definite musculature and provided with claws
- iv) Cuticle has a thin deposit of chitin like that of arthropods
- v) Body cavity is a haemocoel
- vi) The coelom reduced to small cavities that surround the excretory and reproductive ducts.
- vii) Characteristic salivary glands, supposed to be modified nephridia
- viii) Dorsal tubular heart with lateral ostia
- ix) Presence of tracheal respiratory system
- x) Brain is large and typically arthropodan
- xi) General structure of the reproductive organs and development mainly arthropodan.

19.6.3 Onychophoran characteristics

Peripatus has a few characters of its own which are not shared by any other animal.

- i) Body does not show distinct external segmentation
- ii) Texture of skin cuticle is rough and covered with numerous velvety processes not known in other phyla.
- iii) Antennae not homologous to the antennae of other arthropods
- iv) Three segmented head of *Peripatus* shows a condition between that of Annelida and Arthropoda
- v) Restriction of jaws to a single pair. Movement of jaws is anteroposterior
- vi) Presence of unsegmented legs with claws
- vii) Irregular distribution of spiracles of tracheal openings
- viii) Two ventral nerve cords widely separate and without true ganglia -
- ix) Structure of eyes is less complicated
- x) Distribution of reproductive organs.

19.6.4 Molluscan characteristics

Peripatus was previously included with Mollusca due to slug-like appearance of its body and

ladder-like nervous system, as found in Amphineura and Prosobranchiata. But these are only superficial resemblances.

19.7 TAXONOMIC POSITION

Onychophora have both annelidan and arthropodan characteristics. Therefore, they are regarded as an intermediate stage or connecting link between Annelida and Arthropoda. However, they appear to be more closely allied to arthropods than to annelids. They perhaps, arose as an offshoot from near the base of the arthropode line. Based on such phylogenetic considerations, Manton (1958) and other contemporary zoologists have included onychophorans within the Arthropoda as a class or a subphylum. But, absence of an exoskeleton and jointed limbs and the presence of primary annelidan characters in Onychophora create serious problems. Others claim that *Peripatus* is definitely an annelid. In fact, onychophorans are neither worms nor arthropods but have distinctive characteristics of their own. Therefore, Onychophora is removed from Arthropoda and given the status of a phylum.

It is undoubtedly very ancient group because a mid Cambrian fossil, *Ayshealis*, closely resembles the modern Onychophora. Its extreme isolation or discontinuous distribution at present also suggests that the group has lived through many geological ages and that it had been more widespread and diversified in the past. *Ayshealis* and *Peripatus* further suggest that Arthropoda may have evolved from annelid-like ancestors.

Check Your Progress

1. List out separately the annelidian and arthropodan characters in *Peripatus*. Explain whether it is more like an arthropod or annelids.
2.of *Peripatus* is used as an evidence to support the geological belief that equatorial regions of earth were converted by land bridges to the southern hemisphere.

19.9 SUMMARY

External characters of *Peripatus* showing the dermomuscular body and antennae and stumpy legs. Alimentary canal divided into distinct regions. Salivary glands present. Circulatory system has a contractile heart, and Tracheal tubes are respiratory organs. Excretory organs are paired nephridia. Ladder-like nervous system is present. Sexes are separate. Fertilization in few species by a novel method.

Geographical distribution is characteristic in the group and the annelidan and arthropodan characters are enumerated. The present status of Onychophora on the basis of certain characters are unique to these animals.

19.10 CHECK YOUR PROGRESS — MODEL ANSWERS

1. Arthropoda
2. Discontinuous distribution

19.11 MODEL EXAMINATION QUESTIONS

- I. Answer the following questions in about 30 lines.
 1. Describe briefly the internal anatomy of *Peripatus*.
 2. Discuss the affinities of *Peripatus*.
- II. Answer the following questions in about 10 lines
 1. Describe the external characters of *Peripatus*
 2. What is the present status of *Peripatus*.
 3. Describe the digestive system of *Peripatus*.
 4. Describe the reproductive system of *Peripatus*.

UNIT - 20 BENEFICIAL INSECTS

Contents

- 20.1 Objectives
- 20.2 Introduction
- 20.3 Beneficial Insects To Man
 - 20.3.1 Insects as pollinators.
 - 20.3.2 Insects as scavengers
 - 20.3.3 Insects useful in pest control
 - 20.3.4 Insects as food
 - 20.3.5 Dyes
- 20.4 Economic Importance
 - 20.4.1 Sericulture
 - 20.4.2 Apiculture
 - 20.4.3 Lac Industry
- 20.5 Summary
- 20.6 Check Your Progress - Model Answers.
- 20.7 Model Examination Questions.

20.1 OBJECTIVES

Although insects are minute, the activities they are involved in are of a high magnitude. In this unit, the usefulness of insects to man is surveyed. After going through this unit you will appreciate the economic value of some insects to man and his country.

20.2 INTRODUCTION

Insects are the largest number of animals found in this universe. Because of the diversity in their habits and habitats, insects have gained an important place in the animal kingdom. Some of the insects either directly or indirectly control the economy of man.

From the point of view of economic importance the insects are divided into two groups. i) Insects that are beneficial to man and ii) Insects that are harmful to man.

20.3 BENEFICIAL INSECTS TO MAN

These are few in numbers, chief among them are the following.

20.3.1 Insects as Pollinators

Insects also serve man by pollinating the flowers. Among the outstanding pollinators are the bees, wasps, ants, beetles, moths, butterflies and flies.

20.3.2 Insects as scavengers

A few insects feed upon the waste material such as the dead bodies and other garbage. These prevent decay and emanation of bad odour in and around living areas. Silverfish, termites, ants, houseflies, blow flies, maggots, beetles, cockroaches and many other larvae are active scavengers.

20.3.3 Insects useful in Pest control

Insects indirectly help man by attacking and eating up a few harmful insects. Many pests which harm the plants are preyed upon by such insects. Predaceous insects are ground beetles, wasps and a few flies. Aphids and scale insects are eaten by lady bird beetles. Some of the predaceous insects are reared in orchards to control scale insects.

20.3.4 Insects as Food

Many animals feed on insects. In some parts of the world man also feeds on insects as food. Ants, termites, larvae of Goliath beetle are eaten as food by a few Indians, Africans and South American tribals.

20.3.5 Dyes

The dyes known as tannin, cochineal and crimson lake are derived from the dried bodies of certain scale insects living on cacti.

20.4 ECONOMIC IMPORTANCE

Apart from these benefits, three species of insects have attracted the attention of people and are used from ages for the economic growth of man they are i) Silkworm ii) Honey bee and, iii) Lac insect. They are discussed in detail in this unit.

i) **Silkworm - *Bombyx mori***: The cocoon spun by the larvae for the protection of the young one yields the silk and industry is called **sericulture**.

ii) **Honey bee - *Apis indica***: The honey secreted by the animal is stored for its own use in hives called beehives, but man has succeeded to rob the honey for himself. The rearing of honey bees and the collection of honey and bees wax by artificial methods is known as **apiculture**.

iii) **Lac insects**: These produce a waxy material which is put to various uses. *Laccifer lucca*, the scale insect secretes the stick lac of commercial importance.

20.4.1 Sericulture

Silk is the most prized of all the textile fibres. It is the continuous filament exuded by silkworm at the end of its larval period. It is the larva or caterpillar of the moth *Bombyx mori*. It has a small opening under the jaws called the spinneret. The silkworm produces a protein-like viscous substance. This passes through two separate filaments. These are cemented together in the spinneret into a single thread by a gummy substance, the sericin or silk gum. The silkworm uses this thread to spin the oval protective shell, the cocoon. By a continuous movement of its head in arcs of circles, the worm adds layer after layer of silk thread around itself. Thus a continuous thread is spun. The web grows closer and the cocoon is completed in 2 to 3 days. After this the enclosed silkworm passes into the passive pupa stage, the **chrysalis**. For extracting the thread the cocoon is soaked in hot water. Later by unwinding the fibre is reeled. This fibre is the **raw silk** which is of great commercial value. Sericulture includes i) seed production. ii) mulberry cultivation iii) rearing of silkworms, for raising cocoons.

Seed Production: For rearing moths for seed production (egg-laying) the cocoons are usually strung on a thread and hung in a cool, dark place until the moths emerge. The males and females are then put on cheese cloth, where they mate. Later the female lays eggs. The eggs are deposited on the cheese cloth which adheres lightly to the cloth. The eggs are store in a cool dry place until they are hatched. Care is taken to see that the pairing mates are healthy and free from diseases and malformations. 10 gm of eggs contain 20 to 25 thousands of eggs, which will yield 50 to 60 kg of fresh cocoon. The cocoons can produce nearly 5 to 6 kg of raw silk.

Silkworms: There are two types of silkworms i) cultivated silkworms or mulberry feeding silkworms and ii) wild silkworm which feed on various kinds of plants. Fine quality silk is produced by the cultivated silkworms. These are responsible for the major portion of the world silk production. The principal species of mulberry silkworm is *Bombyx mori*. It is completely domesticated and is reared for silk production. It produces a creamy white silk.

Bombyx mori passes through four distinct stages in its life. i) **Egg** ii) **Caterpillar** iii) **Pupa** and iv) **Moth** (Fig. 20.1). The moths which emerge out after completing the metamorphosis, mate within 2 or 3 days. The female lays about 400 to 500 eggs and soon after, the mother dies. When

the moth makes its way through the cocoon (after metamorphosis) the cocoon gets damaged. The silk filament in such cocoons cannot be unwound in on long thread. The life cycle of silkworm is therefore terminated at the pupa stage for the reeling and obtaining the long thread. However, those selected to provide the necessary seed (eggs) for the next brood are allowed to develop into moths.

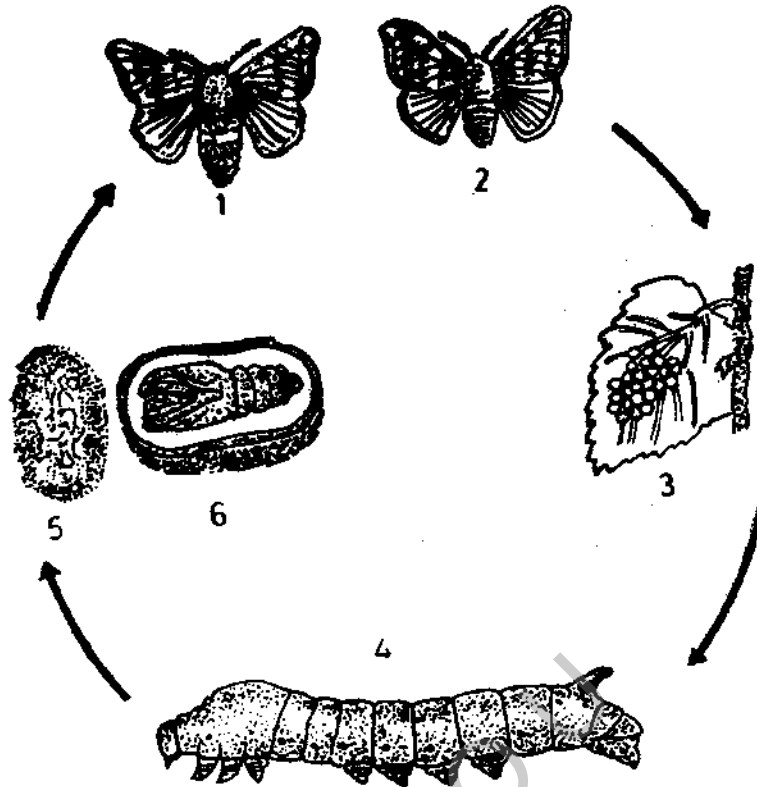

Fig. 20.1 Life history of silkworm moth (*Bombyx mori*), 1. Female adult moth. 2. Male adult moth. 3. Eggs on Mulberry leaf. 4. Caterpillar. 5. Cocoon. 6. Cocoon cut open.

The development of sericulture in an area depends largely on the quality and quantity of mulberry leaves available to feed the silkworms during their larval stage. Mulberry is a hardy, fast growing, deciduous plant which is grown in sub-tropical, tropical and temperate climates. *Morus alba* is the most popular of the species of mulberry plants grown to feed the caterpillars.

The rearing of silkworm is laborious. The larvae are kept in a rearing house on trays in constant shade at a temperature between 65°F and 78°F. They are first fed on chopped mulberry leaves supplied about eight times a day. After 4 or 5 days fresh leaves are put in a tray with a net bottom. The tray that contains the larvae are put on this tray.

As they grow the larvae are transferred frequently to fresh leaves on clean trays. They consume a surprising quantity of leaves which must always be dry.

Today Japan is the largest producer of silk and accounts for over 55 per cent of the world silk production. China, USSR, India and South Korea are the other important silk producing countries.

20.4.2 Apiculture

Bee-keeping was introduced in India only in 1938. It is now a well established industry in the states of Tamil Nadu, Maharashtra, Karnataka and Kerala. Other states also are slowly catching up. However, compared to the size and population of the country, the number of established apiaries is small.

The method adopted in the hill regions to obtain honey from the combs is most unscientific and cruel. The comb is totally destroyed and number of bees are sacrificed in the process. Even the honey extracted is not of a good quality.

In many areas this method has now been given up and is replaced by an artificial method which is more scientific and sophisticated. An artificial hive has a large brood chamber placed on a wooden framework. Provision is made for the entry and exist of the honey bees. The chamber has a number of frames in each of which a wax-sheet bearing hexagonal imprints is held up in a vertical position by a few wires. Bees start ~~walls~~ walls and ~~cells~~ cells along the margins of hexagonal cells. Each wax sheet is called the comb foundation. It attracts the bees by providing the foundation for preparing combs on both the sides. The frames are kept hanging vertically in the brood chamber, which is covered over by another frame. This frame also has a wire-meshing through which workers can pass easily. Another chamber called super is placed over the brood chamber. This also contains similar frames containing comb foundations to provide additional space for the expansion of the hive. The wire meshing referred to above lies between the brood chamber and super. The super is closed from above by a cover having some holes for ventilation, light and safety.

Artificial hives are usually arranged in kitchen gardens, fields and orchards. A queen is introduced with a small colony. A full-fledged colony will be established soon after the queen starts laying eggs for the first brood. When the hive has been active for some time, the combs are removed from the frames. Without disturbing the nest, honey is extracted usually by centrifuging the frames. The bees are brushed aside from the comb for extracting honey. They again start activity on re-introduced combs. The larval stages remain uninjured.

The equipment required in apiculture include the following - artificial hive, a smoker, a net veil, a bee net, a pair of gloves, a knife, a brush and a centrifuge for extracting honey.

Bee hive: The colonies of honey bee are perennial. A healthy colony has 40 to 50 thousand bees. Each colony consists mainly of three castes namely queen or fertile female, drones or males and workers or sterile females. In a colony there is only one queen, a few drones and more then 95 per cent of workers. Queen and the worker bees develop from the fertilized egg while the drones develop parthenogenetically (Fig. 20.0).

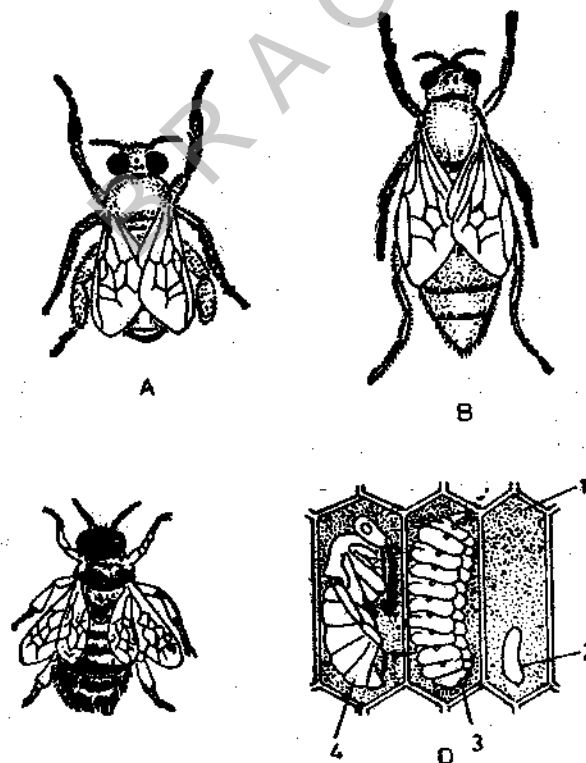

Fig. 20.2 Honey Bee — Life cycle A. Worker. B. Queen. C. Drone. D. Stages in the development. 1. Beehive. 2. Egg. 3. Larva. 4. Pupa.

In India three species of honey bees are commonly found, namely *Apis dorsata*, *Apis indica* and *Apis florea*. *Apis mellifica* is the European honey bee. *Apis adamsoni* is the African honey bee.

Honey: The bee collects nectar from the flowers and stores it in its crop before regurgitating it into the cells of the hive. The saliva of bee converts the nectar of the flowers into honey of the bees.

Honey is an important food item of man. It has a lot of medicinal value. It is used as an antiseptic. It is also used to cure certain gastric disorders.

Bee wax: Bee wax is a by-product of bee-keeping in most areas. When the bee keeper uncaps or breaks honey combs or has unusable combs he attempts to salvage the bees wax. First he recovers as much honey from the combs as possible. Then he places the material in water heated to slightly over 145°F. This melts the wax which rises to the surface. After it cools and hardens the cake of wax is removed and refined for use in the comb formation. Bees wax has many other uses also. It is used in preparation of quality candles, cosmetics, agriculture, art and in many industries.

Bees reared and sold: In apiculture bees are reared for sale to other bee keepers for requeening established colonies.

Bees as pollinators: The honey bees are probably of greatest importance to agriculture in the pollination of plants. They are the only pollinating agents which can be controlled by man. Certain orchard farms have no value without the aid of bees. It is believed that nearly 80 percent of insect pollination is done by honey bees.

20.4.3 Lac Industry

Lac is the resinous protective secretion of the tiny lac insect (Genus *Laccifer*, family *Laceferidae*, order *Hemiptera*) which is a pest on a number of plants, both wild and cultivated.

The commonest and the most widely occurring species of lac insect in India is *Laccifer lacca* which produces the bulk of commercial lac.

Life history: The insect starts its life as a minute boat-shaped, red-coloured larvae 0.55 mm. long and 0.22 mm broad. The larvae emerge in large numbers from the lac cells of the insect and crawl over the surface of twigs, branches of plants they infest. A healthy female produces 300 to 1000 larvae. After a brief period and depending on favourable weather conditions the larvae emerge from the cell in search of suitable places for settlement. The proportion of male to female larvae in the brood varies but generally it is 1:3. The density of settlement in the shoots is usually 150-180 larvae per sq. cm. Once settled the larva does not move from its place (Fig. 20.3).

A week or so after settling, the larvae start secreting lac from glands distributed under the cuticle all over the body, except the mouth parts, the two breathing pores and anus. It thus gets enclosed in a cell of its own secretion which increases in size with the growth of the insect. The larva moults thrice before reaching maturity. The duration of each of the three larval stages depends on environmental factors such as temperature, humidity and host plant. The sex is readily recognised by the shape of the cell even at the early stages of larval development. The male lac cell assumes a slipper-like appearance. After the completion of second moult the pupal stages, the adult male, which may or may not have wings, emerges out.

The female larva becomes swollen and assumes the form of a pearshaped or roundish bag which completely occupies the space inside the lac cell. After the third moult the female is sexually mature and is fertilized by the male which has a life of 62-92 hours after emergence. Lac secretion by the female continues, and the size of the insect as well as that of the enclosing lac cell increases at a fast pace. The female lac cell attains a size which is several times that of a male lac cell. The female continues to secrete lac until the eggs are laid.

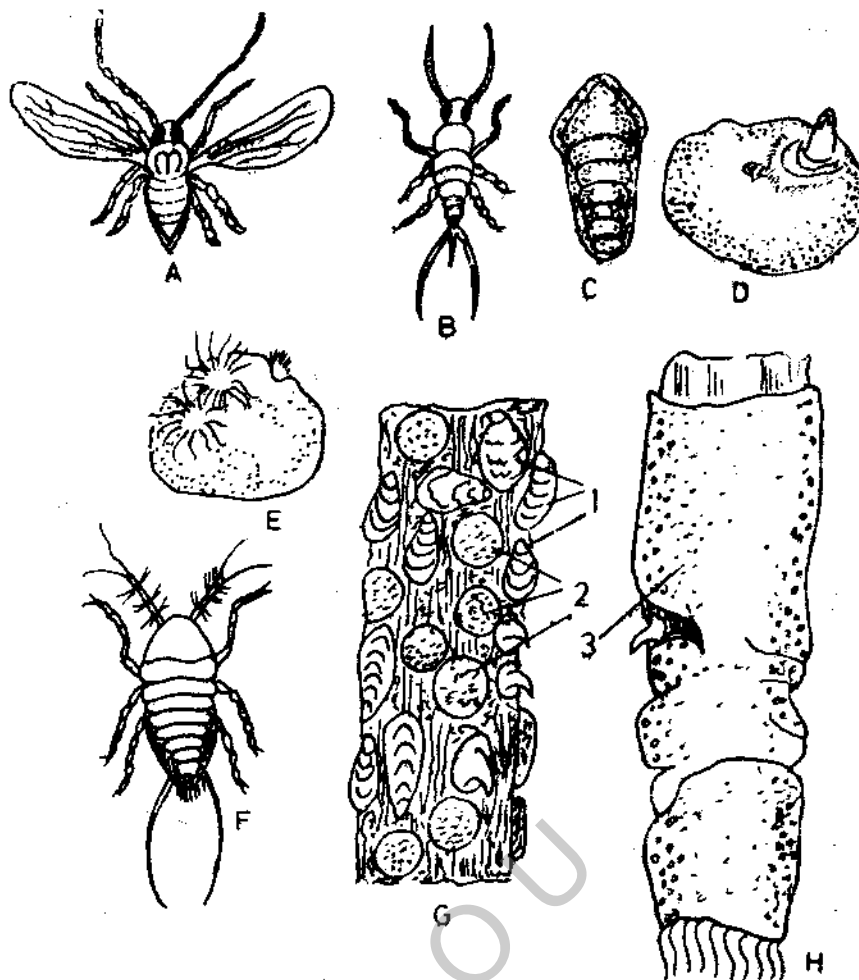

Fig. 20.3. Lac insect. A. Winged male adult. B. Wingless male. C. Male lac cell. D. Female adult. E. Female lac cell. F. Larva. G. Male and female lac cells on the twig of *Ziziphus* tree. H. *Ziziphus* tree with encrustation of lac. 1. Male lac cells. 2. Female lac cells. 3. Lac encrustation.

The anal tubercle is withdrawn inside the cell for laying eggs. Larvae hatch out from the eggs when the temperature is suitable.

Host Plants: There are well over a hundred species of plants in which lac insects have been recorded in India. But from the point of large-scale production the following plants are important *Butea monosperma*, *Ziziphus mauritiana*, *Ziziphus xylopyres*, *Ficus cumia*, *Cajanus cajan*, *Albizia lucida*, *Acacia catechu*

Lac Cultivation: Cultivation of lac has been carried on by peasants in forest, subforest areas where suitable host plants exist. This is done as a subsidiary occupation. In our country the important areas of lac production are Bihar, Madhya Pradesh, West Bengal, Assam, Orissa, Maharashtra, Uttar Pradesh and Andhra Pradesh.

Lac cultivation is initiated from brood lac. This is the twig of host tree carrying lac encrustations with larvae about to emerge from the mother cells. The wings are cut, bundled and tied at convenient places on a fresh host plant. The larvae which emerge out swarm and settle on nearby succulent shoot. Lac cultivation needs a lot of careful management. The Indian Lac Research Institute at Namkum, Bihar is doing good work. Improved techniques of cultivation have been evolved and efforts are being made to popularise them among lac growers.

India held a virtual monopoly of lac production till about 1950. 85% of the world's lac production was accounted by our country. Now Thailand is a serious competitor. It is able to meet 25 to 30 per cent of the world's requirement.

Check Your Progress

1. Name a flower pollinating insect
2. Termites, cockroaches and house flies are
3. gum is used to combine silk filaments in theby the silk worm which is scientifically known as
4. Honey is the combination of flowers andof honey bee which belongs to the genus

20.5 SUMMARY

Based on the economic importance insects are of two types - beneficial and harmful. The different beneficial activities of insects explained in brief. Sericulture is the silk industry. The insect responsible for silk production is studied in detail. Apiculture is rearing honey bee for obtaining honey and other useful products. Domestication of honey bee and the yield of honey and bee wax explained. Lac is obtained from lac insect. Lac cultivation and the method of getting lac is explained.

20.6 CHECK YOUR PROGRESS — MODEL ANSWERS

1. butterfly
2. scavengers
3. Sericin, spinneret, *Bombyx mori*
4. nectar, saliva, *Apis*

20.7 MODEL EXAMINATION QUESTIONS

- I. Answer the following in about 30 lines.**
1. Write an essay on beneficial insects
 2. Write an essay on sericulture, apiculture and lac cultivation.
- II. Answer the following in about 10 lines.**
1. How are honey bees are useful to man? Add a note on apiculture.
 2. What is lac? How is it formed? Add a note on lac cultivation.

UNIT-21 HARMFUL INSECTS

Contents

- 21.1 Objectives
- 21.2 Introduction
- 21.3 Crop Pests
- 21.4 Gall Forming Insects
- 21.5 Locusts
- 21.6 Stored Grain Pests
- 21.7 Household Pests
- 21.8 Insects That Transmit Diseases To Man
- 21.9 Insects Injurious To Domestic Animals
- 21.10 Termites
- 21.11 Control Methods
 - 21.11.1 Culture method
 - 21.11.2 Mechanical control
 - 21.11.3 Chemical control
 - 21.11.4 Biological methods
- 21.12 Summary
- 21.13 Check Your Progress — Model Answers
- 21.14 Model Examination Questions
- 21.15 Glossary

21.1 OBJECTIVES

To identify the harmful insects and to assess the extent of damage they cause. Damage to agricultural crops and products, transmission of diseases to human beings and his domestic animals and controlling measures are the points which will be well explained by you.

21.2 INTRODUCTION

We have examined in the previous lesson that a few insects are of great use to man and the products they produce add to our economy. However, man has to fight intensely against a few other insects which adversely affect his economy. These insects which injure or destroy his crops, stored grains, household materials and also those which spread diseases are known as harmful or injurious insects, because they cause extensive damage to person and property. Entomologists all over the world are experimenting to find possible solutions to solve this global economic problem. From the point of view of the economic loss they cause, the insects may be considered under the following heads:

1. Crop pests.
2. Stored grain pests.
3. Household pests.
4. Insects that transmit diseases to man.
5. Insects injurious to domestic animals and
6. Termites.

21.3 CROP PESTS

Many insects damage farm crops, fruits and vegetables on the field. The damage they cause runs into lakhs and lakhs of rupees.

Nephotettix, the Indian rice leaf-hopper, *Leptocorisa*, the oriental pest of rice and millet belong to order Hemiptera. These attack the paddy plants extensively eating away the leaves and ears. The

larvae of *Schoenobius*, a moth bore into the rice plant and kill the plant. Nymphs and adults of *Hieroglyphus*, an Orthopteran eat up the growing shoots of rice plants. These prevent formation of grain.

Mystiola, the Hessian fly is a small-sized midge. The flies lay their eggs in the grooves of the upper surface of the leaves of young wheat. The eggs hatch in 3 to 12 days and the small red larvae make their way down the leaf and behind the sheaths. These begin feeding on the tender tissues of the plant.

The larvae of two Lepidopterans *Chilo* and *Diatraea* bore into stems of sugar cane. The stems are made hollow at regular intervals by feeding on the tender tissue. *Pyrausta* is a bug commonly called sugar-cane leaf-hopper found all over the world. They are particularly abundant in the tropics. Both the adults and nymphs cause great loss to the sugar-cane by sucking the juice from the cane. Among the enemies that attack sugarcane under-ground are wire worms and several small soil-inhabiting insects and related animals.

Dysdercus, the Indian cotton bug, *Oxycarenus*, the Egyptian cotton bug and *Anthonomus*, the cotton-boll weevil are very injurious to cotton. They stain and destroy cotton-bolls. *Aphis*, a hemipteran is a serious cotton pest in India. The pests often attack cotton plants in large numbers causing the plants to wilt and die. Aphids secrete a sticky substance known as honeydew which drops on the leaves and bolls. The honeydew gives the plant a glossy appearance. Honeydew falling on the open bolls makes the lint gummy and difficult to gin.

Agrotis and *Gnorimoschema* are Lepidopterans. These are commonly known as **potato cut-worms**. The larvae of *Agrotis* feed on potato leaves and cut off the stems. The larvae of *Gnorimoschema* on the other hand eat the potatoes in the field. The larvae of *Agrotis* also cause damage to peas, cabbage, tobacco, groundnuts, wheat and cauliflower. Tobacco and tomato are damaged by the larvae of *Gnorimoschema*.

The grubs of Coleoptera are also called **wireworms**. They are rootfeeders. They are extremely destructive to grasses, root crops and cereals.

Many insects and their larvae are destructive to vegetables and fruits *Siphocoryne* is an aphid which feeds on cabbage leaves. *Anasa*, the squash bug is destructive to cucurbitaceous plants. *Earias* the spotted boll-worm damages ladies-finger plants. *Aulacophora*, the red beetle feeds on pumpkins. The larvae of *Bruchus*, a beetle bores into the pods of bean and peas and kills all the seeds.

Drosicha, a bug causes extensive damage to mangoes, plums, papaya, pears, citrus and jack fruits. *Ideocerus*, a mango leaf-hopper attack the inflorescence and suck the plant juices. They cause heavy loss to the mango crop by preventing formation of mango fruit. *Psylla* an apple bug lays eggs on apple and pear trees. The nymphs on hatching damage the tender leaves and the buds *Anthonomus*, a beetle also destroys the inflorescence of apple and prevents formation of the fruit. *Nysius*, a bug is very destructive to several kinds of fruit trees.

21.4 GALL FORMING INSECTS

Apart from damaging the productivity aspects of the plants, insects also cause certain malformations in plants. These are called galls.

Galls are peculiar growth produced by a number of insects on plants. Chief among those are the dipterous gall midges or gall flies and gall wasps of the Hymenoptera. Certain species of thrips, lace bugs, psyllids, aphids, beetles, weevils etc. also produce plant galls.

Galls are produced on different plants. The galls are usually three quarters of an inch long. In appearance these resemble miniature pine-apples. Many of the infested twigs die. The trees may be deformed and weakened by heavy or repeated infestations. Some species of gall wasps undergo an alternation of generations. In one generation galls are formed on the stem and branches. In the next generation they develop a root gall.

Larvae develop in the galls. The galls may also be inhabited by many other kinds of insects. Sometimes these feed upon the gall-forming insect itself.

Some galls are also helpful. The galls of Chinese aphid *Melanaphis chinensis* are artificially reared in China. This is done in commercial quantities as a source of dye and tannin and for medical purposes.

21.5 LOCUSTS

The literal meaning of the words 'locust' is plague. The locusts are also known as grasshoppers. Both nymph and adults eat many kinds of vegetation. They migrate in swarms into new feeding grounds and totally damage the crop. *Locusta migratoria* (Fig. 21. A), the migratory locust of the eastern hemisphere has a great reputation since Biblical times. The swarms half-a mile thick, 100 miles wide and 300 miles long of *Melanoplus maxicans*, the rocky mountain locust of North America, contained nearly 127 billion locusts. The locusts are said to have left fields as barren as if they had been burnt over.



Fig. 21.1. A. *Locust* (Orthoptera) B. Queen termite (Isoptera).

21.6 STORED GRAIN PESTS

Insects destroy at least 5 per cent of the world production of cereal grains. Weevils, flour beetles and many other barn beetles devour at least their own weight of food each week. Their larvae are more destructive during the 3 or 4 weeks of their development. Insects may do other kinds of damage. Many species feed entirely on the germ of the grain making the seed nonviable. This results in larger amounts of infested than uninfested grain being used for seed. The pests frequently cause grain to heat. A musty odour may also result. Deterioration and rotting of surface grain may be caused by the translocation of water vapour from the heated area to the cooler surface grain. Finally, the milling quality of the grain also will be drastically reduced by the presence of larvae in the kernels.

The insect pests of stored grains and seed depend on their food supply for water. Seed or grain that is low in moisture is unfavourable for their development.

Many moths, caterpillars and beetles cause a great deal of damage to stored grains. *Tenebrio* and *Tribolium* are two beetles commonly found in stores and granaries. *Tenebrio* is found in all stages in meal, flour and stored foods. Its larvae are known as meal worms. *Tribolium* eats stored wheat and grain. *Calandra*, a weevil bores through grain of rice and other stored grain in our country.

The seed or grain is usually dried to remove the moisture. Then it is stored in bins or bags in warehouses. Fumigants specific to the grain has to be used.

21.7 HOUSEHOLD PESTS

The many kinds of pests that invade households cause trouble in numerous ways. Human foods are eaten or spoiled by cockroaches, weevils, ants, beetles, silverfish, houseflies etc.

Cockroaches live in the shelves or cupboards in the kitchen or bathroom. They are nocturnal in habit. These feed on any type of food they come across. If not controlled at the proper time large numbers occupy every nook and corner of the kitchen.

The other pantry pests include several kinds of weevils, beetles and moths. These infest flour, meal, cereals, spices and other dry foods in the house.

Lepisma, the silverfish lives in bookcases, around closet shelves, behind framed photos and window or door frames. During warmer seasons they may be seen where books and papers are present. The silverfish feed on starchy materials, papers and books. They sometimes cause serious damage to woollen clothes.

Anthrenus, the carpet beetle sometimes called 'buffal moth' is a scavenger eating decaying animal matter. The larvae destroy carpets and other clothes.

Temiola, *Tinea* and *Trichophaga* are clothes moths. Their larvae feed on articles that contain wool, rayons, fur etc. They usually spend all their time right on the article upon which they are feeding.

Wasps, some kinds of ants may sting man. Bedbugs, lice, fleas, mosquitoes, sand flies suck blood from man or his household pets.

Some pests may cause no particular damage but are a nuisance just by their presence in homes. Eg. Drain flies, some kinds of ants, springtails etc., *Psocids* or booklice thrive best where there is high humidity. They are often abundant in new homes until the plaster and wood become thoroughly dried out.

Good house-keeping and thorough sanitation are of utmost importance in controlling or preventing infestations of many kinds of household insects. The removal of garbage, bits of food, soiled clothes and other materials deprive the insects of food and hiding place. If such things are allowed to remain a few or many insects may develop there and spread to places where they will cause damage or annoyance.

21.8 INSECTS THAT TRANSMIT DISEASES TO MAN

Many insects play an important role in spreading serious diseases in man. Many of them act as intermediate hosts. Diseases are caused by a variety of organisms or parasites such as viruses, bacteria, protozoans and worms. Insects often act as vectors or carriers spreading them from one host to another. The various species of *Anopheles* mosquito have been found to convey one or other parasitic Protozoa causing malaria. Certain *Culicine* mosquitoes spread the nematode worm, *Filaria bancrofti* which causes filariasis in man. Yellow fever is spread by another mosquito, *Stegomyia (Aedes)*. Dengue or breakdown fever also is caused by the mosquito, *Aedes*. Similarly Encephalitis caused by viruses is spread by several species of mosquitoes. African sleeping sickness is caused by tsetse fly, *Glossina*.

Phlebotomus is the vector of *Leishmania donovani*. They transfer these disease producing by injecting them into the blood stream. A few other diseases such as cholera, typhoid and diarrhoea are spread by the housefly, *Musca domestica*. These diseases are transmitted by contaminated food. Bubonic plague is caused by rat flea and relapsing fever by bed bug and body louse.

21.9 INSECTS INJURIOUS TO DOMESTIC ANIMALS

Just as man is a victim of untold miseries, so also are many domestic animals which serve man in one way or the other. Tsetse fly, *Glossina* transmits *Trypanosoma brucei* which causes nagana in horses. Horses and cattle are affected by another species of *Trypanosoma*. *Tabanus* and *Stomoxys*, the blood-sucking flies are the vectors. The larvae of *Hypoderma*, the warble fly infect the ox and cause skin diseases. *Gasterophilus*, the bot-fly larvae enter the stomach of horses and cause disease. *Hippobosca*, the forest fly of cattle and horses suck blood from the hosts and cause haemorrhage. *Menopon*, the chicken louse sucks blood and causes damage to poultry.

21.10 TERMITES

They are social insects living in colonies with an elaborate polymorphism. They feed mainly on cellulose. *Trichonympha*, a flagellate living in the intestine as a symbiont helps in the digestion of cellulose. They build subterranean nest called termitarium.

The termites exhibit polymorphism — winged fertile males and females (Fig. 21.1B) and sterile, wingless workers, soldiers etc. The termites cause immense loss to man. They are highly destructive and damage timber. They damage costly furniture, doors and windows, books and papers. They are particularly destructive to record rooms and other store-houses. It may look paradoxical to say that they are beneficial to man in its own way. They help the agriculturist by making the soil fertile. In some parts of Africa natives feed on termites. They are rich in iron, vitamin A and calcium.

21.11 CONTROL METHODS

One of the most challenging features of economic development has been the control of insects causing extensive damage to crops, stored grains, public health etc. It is estimated that five hundred crore rupees are lost annually on account of insect pests. Nations all over the world have taken up control measures on a war-footing. The following are some of the control methods.

1. Cultural methods
2. Mechanical
3. Chemical
- and 4. Biological

21.11.1 Cultural method

Cultural methods are practised by farmers. These include efficient farm management. This does not involve extra costs. Often they require only minor changes in the usual cropping procedures.

Delaying the seeding of crops helps in keeping the infesting pests away. The timing is usually so adjusted that it is termed 'fly-free dates', in the language of farmers.

The proper disposal of crop residues help control insects. The plant debris provides good breeding grounds and also food for the developing larvae. Total drying, burning of residue, spraying of chemicals are some of the methods employed to destroy the pests. Ploughing tools also help to remove the residues properly. Sugarcane, paddy and cotton are some of the crops which need such attention.

Rotation of crops is another very important method to control the pests. This is of advantage in insects which feed particularly on a type of food. Cultivating leguminous plants after the cereals is commonly practised.

Early harvest of crops also may help prevent losses. This prevents the kernel being affected by the pests.

21.11.2 Mechanical control

In this method insect population is reduced by means of devices which alter their physical environment. Hand-picking, and trapping are familiar mechanical methods of insect control. Screens, barriers, sticky bands and shading devices also help to control insect population. Physical controls include the use of electricity, sound waves, infra red rays, X-rays or light to kill insects. The most common method is to employ heat to cold. Cold storage usually cuts down the insects activity. Heat also inhibits insect development.

21.11.3 Chemical control

Chemical control is the most extensively employed method for killing insects. The chemicals are known as insecticides or pesticides. The following are some of the insecticides commonly used for controlling harmful insects.

Inorganic compounds: Lead arsenate is used for controlling leaf eating caterpillars of codling moth. Paris green, Sodium fluoride, Lime sulphur, Calomel etc., are a few other effective inorganic chemical pesticides.

Organic compounds: Nicotine is an alkaloid found in tobacco. It is a contact poison. It controls insect pests such as aphids, mirids, thrips and sand flies.

Pyrethrum is prepared from dried heads of some species of *Chrysanthemum*. It is used in control of insects in ware-houses, green houses and household pests.

Derris a stomach poison prepared from roots of *Derris* and *Lonchocarpus* (both Leguminous plants) is used against crop pests and ectoparasites on livestock. It has a substance rotenone.

Synthetic pesticides: **Dinitrophenol** is used as insecticide in petroleum oil. It is effective against eggs of aphids, psyllids, spider, mites etc.

D.D.T. (Dichloro-diphenyl trichloroethane): It is a contact and stomach poison against a wide range of insects. Affected surfaces remain toxic to insects for a long period. D.D.T. in emulsion form serves to control a number of aphids. D.D.T. should be carefully used on edible foliage crops.

B.H.C. (Mixed isomers of 1, 2, 3, 4, 5, 6 hexachlorocyclohexane or gamma xene) It is a highly effective pesticide. It has also an effective fumigant action. It has 99% gamma B.H.C. It has less residual problems than D.D.T. when used on edible Crops.

Aldrin, *Dieldrin* and *Endrin* are used against a wide range of crop and foliage and fruit pests. Endrin is more poisonous than aldrin and dieldrin.

Contact poisons: **Parathion** and **Malathion** are organophosphorus compounds. These control a wide variety of insects. Residual action remains upto ten to fourteen days.

Fumigants: **Carbon disulphide** is a poisonous and highly explosive liquid with unpleasant smell. It is used as a soil fumigant. It is effective but expensive.

21.11.4 Biological methods:

These include killing of organisms which help insects, pests, introduction of parasitic or predatory organisms. The insects which attack and eat up other insects are called predators. Ground beetles, lady bird beetle, wasps, lace wing flies are a few of the many predaceous insect. Some parasitic wasps have control over cutworms. Several insects are preyed upon by birds, snakes and toads.

Check Your Progress

1. Stored grains are damaged byandbeetles.
2. Musca, Anopheles, Phlebotomus which are transmitters of various diseases belong to order
3. The best and efficient way so far known and employed to control the insects is the method.

21.12 SUMMARY

The various types of crop pests are described.
The effect of the insects on stored grain is described and also suggestions to protect them.
Household pests and the different types of materials they affect are explained.
The steps one should take to prevent the infestation of many kinds of household pests.
The disease causing organisms and the vectors mosquito, flies etc. are listed out, and even the live stock are not spared by some of these insects.
Termites and the extent of damage they cause is explained.
The life histories of a few pests and insect vectors are described.
The various control methods are discussed in brief.
Indiscriminate use of pesticides affects human beings and livestock.

21.13 CHECK YOUR PROGRESS — MODEL ANSWERS

1. Tenebrio,
2. Diptera
3. Chemical
4. Tribolium

21.14 MODEL EXAMINATION QUESTIONS

- i. Answer the following in about 30 lines
 1. Write an essay on harmful insects.
 2. Briefly describe the life histories of any two pests.
 3. Write an essay on control methods of harmful insects.
- II. Answer the following in about 10 lines.
 1. Write briefly on insects which are injurious to crops.
 2. Write on household pests.
 3. Write on insects which transmit diseases to man.
 4. Describe the life history of house fly.
 5. What are pesticides? Add a note on hazards of insecticides.

21.15 GLOSSARY

Apiculture	:	Rearing of honeybees for honey.
Autotomy	:	Separation of a part of the body as a measure to protect itself from the enemies.
Aquatic	:	Animals living in water
Bays	:	An inward bend of the shore.
Benthic	:	Deep sea or bottom dwelling animals.
Branchiostegites	:	These are convex flaps, which are lateral extensions of the carapace in a few crustaceans. These act as gill covers.
Carapace	:	The chitinous exoskeletal shield covering the cephalothorax of crustaceans.
Chitin	:	A polysaccharide protein compound which forms hard substances in animals. Exoskeleton of arthropods is chitinous.
Cephalothorax	:	Fusion of head and thorax in most of the crustaceans.
Ecdysis or moulting	:	Most arthropods and a few other animals during development cast off the outer skeleton. This process is known as ecdysis.
Exoskeleton	:	It is the outer hard covering of the body which acts like the external skeleton.
Extinct	:	Organisms which lived in the past and whose fossils only now exist.
Euryhaline	:	Animals tolerant to a relatively wide range of environmental salinities. These will be usually lower than that of the open ocean.
Eurythermal	:	Animals which are tolerant to a relatively wide range of environmental temperatures.
Fossils	:	Remains to those animals which lived in the past.
Gonoducts	:	Principal duct for the transport of sperm or eggs in any reproductive system (vas deferens or oviduct).
Haemocoel	:	Blood filled body cavity as seen in cockroach and other arthropods.
Lagoons	:	A shallow lake communicating with the sea. Usually a lake formed by the coral reef.
Malpighian tubules	:	Minute tubes in a few arthropodans, which are excretory in function.
Nekton	:	Actively swimming organisms in any part of the water column.
Opisthgoneata	:	Myriapoda in which the gonopore is in the posterior part of the animal.
Parthenogenesis	:	Development of an unfertilized egg producing a young one.

Pectines	:	Comb-like appendages present in the sternum of mesosoma of Scorpion.
Phylogeny	:	History of the race or relationship of the individual with the ancestors.
Pleura	:	Exoskeletal plates or the lateral part of most of the arthropods connecting the dorsal tergum and ventral sternum.
Polymorphism	:	Animals existing in more than 2 or 3 forms as in the colony of termites.
Progoneata	:	Myriapoda in which the gonopore is located in the anterior end.
Pygidium	:	The posterior most segment or segments usually. Also known as the anal segment in a few arthropods.
Regeneration	:	Growth of parts lost due to injury or during autotomy.
Sericulture	:	Rearing of silkworm moth and its larvae for silk production.
Sexual dimorphism	:	Animals exhibiting characters which differentiate the male from the female even by external appearance.
Spiracles or stigmata	:	Respiratory openings bordered by cilia or fine bristles. These lead into the tracheae.
Spermatophores	:	A package of sperm usually formed within a specialized part of the male reproductive system.
Sternum	:	Ventral exoskeletal plates of most of the arthropods.
Tergum	:	Dorsal exoskeletal plates of the most of the arthropods.
Terrestrial	:	Animals living on land breathing air.

BRAOU

UNIT-22 ECHINODERMATA — GENERAL CHARACTERS AND CLASSIFICATION

Contents

- 22.1 Objectives
- 22.2 Introduction
- 22.3 General Characters
- 22.4 Classification
 - 22.4.1 Sub-phylum - Echinozoa
 - 22.4.2 Sub-phylum Homalozoa
 - 22.4.3 Sub-phylum Crinozoa
 - 22.4.4 Sub-phylum: Asterozoa
- 22.5 Summary
- 22.6 Check Your Progress — Model Answers
- 22.7 Model Examination Questions

22.1 OBJECTIVES

To present diagnostic characters an outline classification of Phylum Echinodermata upto the level of classes with important characters and examples of each class. After going through this unit you readily explain the pentamerous radial symmetry, peculiar water vascular system and enterocoelous nature of coelom in this exclusively marine group of invertebrates.

22.2 INTRODUCTION

Echinoderms (Gk. echinos: hedgehog (spiny); derina: skin) the spiny-skinned animals, are superficially **radially symmetrical**, most commonly **pentagonal**, with five rays or arms. All are **marine bottom dwellers** and a very few are found in brackish water. The characteristic **external skeleton** is of calcite (a crystalline form of calcium carbonate), rods or spicules and plates embedded in the skin. The plates are joined at their edges to form a shell and are mostly covered with spines. They are **triploblastic** with **enterocoelus coelom**. The group has an unique **water vascular system** with delicate projections called tube-feet of podia. Nephridia, head and brain are absent. The gonads open directly to the exterior by special ducts. The life cycle exhibits many larval forms, depicting evolutionary significance. Some 6,000 living and many more extinct species are known.

Echinoderms are very ancient animals, having appeared some 600 million years ago in the Cambrian period. The name Echinodermata was given by Jacob Klein in 1734. It was established as a distinct group of Metazoa in 1847 by Leuckart.

22.3 GENERAL CHARACTERS

Echinodermata possess many unusual unparallel characters which distinguish them from other animals. The different important characteristic features of phylum Echinodermata are as follows:

1. They are found in **deep sea water** in almost all the seas of the world. They are present sometimes in brackish water.
2. Free-living, non-colonial, slow moving animals. A few are pelagic and yet some are sessile or sedentary.
3. Body unsegmented. Shape varied—star like, disc-like, cylindrical, flattend or flower-like.
4. Size moderate. The largest starfish spreads to about 32 inches and another form may attain a length of 6 feet.
5. They are found in various colours.

6. Body symmetry, superficially radial, is **pentamerous**. The larvae have a bilateral or **biradial symmetry**.
7. **Triploblastic** with three germinal layers-delicate and ciliated epidermis, middle dermis and an inner lining of peritoneum.
8. A head and an anterior end is absent. Body has two distinct surfaces, an **oral surface** with mouth, and an **aboral surface** with five symmetrically radial areas called **ambulacral areas**, which are intercepted with five alternating interambulacral areas.
9. Both an exoskeleton and an endoskeleton present. **Endoskeleton** is mesodermal, thick and calcareous, consisting of numerous fixed or movable **calcareous plates** or ossicles. The plates are embedded with movable and immovable spines, assuming the shape of a **spiny skin** from which the name '**Echinodermata**' has been derived.
10. Body cavity or coelom is well developed, spacious, **enterocoelous**, lined by ciliated peritoneum. It surrounds various organs and contains coelomic fluid in which lie many free amoebocytes.
11. The organ systems are highly developed and organised.
12. A unique **water vascular system** or **ambulacral system** or **hydrocoel** is found, which consists of reservoirs and ducts containing watery fluid of blood and lymph.
13. Locomotion is carried out by the ambulacral system which pushes out contractile **tube feet** or **podia**.
14. The alimentary canal is complete, running from the mouth to the anus. In some groups anus may be absent or non-functional. Food is also captured by the tube feet.
15. **Respiration** is performed by minute contractile dermal branchiae called **gills** or **papulae**. They are found on the aboral surface and are protected by modified spines called **pedicellariae**.
16. The **circulatory system** is called a **haemal system**. It is simple and of the **open lacunar** type. A heart is absent, but blood vessels are present.
17. No definite organs of excretion. However, elimination of nitrogenous wastes takes place by diffusion.
18. **Nervous system** simple without a brain. It consists of circumoral ring, surrounding the mouth, and radial rings.
19. Organs of special sense inadequately developed. They comprise simple tactile tentacles, pigment eye spots, and statocysts.
20. Sexes are separate and distinct. Reproduction sexual. Gonads are interradial with separate ducts to the exterior. Fertilization external in the sea water.
21. Development may be direct or indirect. Different larval forms are met in different groups. The larvae have **evolutionary importance** as they resemble that of the succeeding higher group.
22. **Asexual reproduction** also occurs by **autotomy** and **regeneration**.
23. They are of considerable economic importance as well as of great concern. They not only serve as food but also destroy commercial oysters.

22.4 CLASSIFICATION

Phylum Echinodermata has been recently classified by Fell in 1965 into four sub-phyla. Each sub-phylum comprises different classes. The classification is as follows:

22.4.1 Sub-phylum - Echinozoa

It is divided into five classes. The distinguishing character and examples of these classes have been mentioned below:

i. Class: **Helicoplacoidea**

1. Free-living ancient echinoderms, reported from lower Cambrian era of California.
2. Body fusiform.
3. The plates of the body wall form a flat test, folded in counter clockwise helical spirals.
4. Oral and anal apertures at opposite ends of the body.

Example: *Heliocoplacus*

ii. **Class: Holothuroidea**

1. Free-living ancient echinoderms.
2. Body elongated, cylindrical, five sided, cucumber-like.
3. Arms absent.
4. Body wall soft, without spines or calcareous plates.
5. Endoskeleton of many microscopic spicules or ossicles.
6. Mouth is surrounded by a ring of retractile branched tentacles.
7. The posterior end has the anus.
8. On each side of the body is found a double row of suckorial tube feet.
9. No pedicellariae.
10. Alimentary canal long coiled.
11. Ambulacral system well developed.
12. Nerve ring surrounds the mouth. It spreads into five radial nerves.
13. Sexes separate.

Examples: *Cucumaria* (Fig. 22.1A) *Molpadia*, *Thyone* (Fig. 22.1 B)

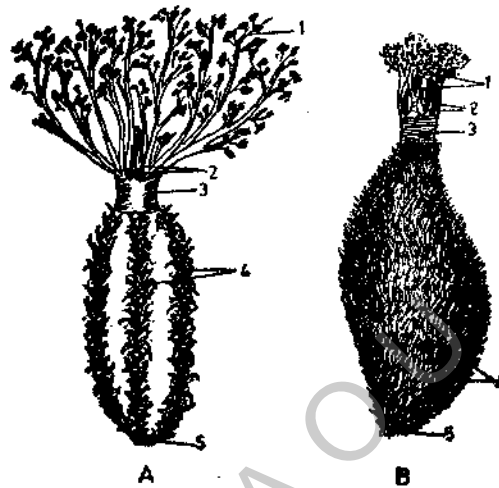

Fig. 22.1 Echinoderms. A. *Cucumaria planici*. B. *Thyone*. 1. Normal dendritic tentacles. 2. Dwarfed midventral pair of tentacles. 3. Introvert (collar). 4. Ventral locomotory podia. 5. Anus.

iii. **Class: Edrioasteroidea**

1. Appeared in mid-Cambrian period and became extinct in Carboniferous era.
2. Test flexible.
3. Mouth and anus both are on the upper side of the test.

Examples: *Edrioster*, *Isorophus*

iv. **Class: Echinoidea**

1. Body shape is globular, discoid or heart-shaped.
2. Body is enclosed in a well developed test.
3. Mouth and anus in the oral and aboral surfaces respectively.
4. Endoskeleton of immovable calcareous ossicles.
5. Surface of the body consists of cylindrical, solid, movable spines which can turn in all directions.
6. Five double rows of suckorial tube feet are found among the spines.
7. Ten shrub-like dermal branchiae are found on the peristome.
8. Inside the mouth a complex, specialised jaw mechanism, the Aristotle's Lantern, is present. It is in the shape of a five sided pyramid and has five long and curved teeth.
9. Pedicellariae are stalked and possess three jaws.
10. A vascular gland is found associated with the water vascular system. It is probably excretory in function.
11. Alimentary canal is tubular.

12. Sexes are separate.

Examples: *Echinus* (Fig. 22.2 A) *Clypeaster* (Fig. 22.2 B) *Lovenia*, *Echinocardium* (Fig. 22.2 C)

V Class: Opisthocistididea

1. Extinct echinoderms.
2. Polygonal plates found on the test.
3. Mouth with five interradial jaws.
4. Eight pairs of tube-feet arise from each ambulacrum.

Example: *Volchovia*

22.4.2 Sub Phylum: Homalozoa

1. Extinct echinoderms.
2. Body dorso-ventrally flattened.
3. Bilateral symmetry wanting
4. Mouth possesses a pair of arm-like organs on either side.
5. On the opposite end, a locomotor appendage in the shape of a tail like peduncle is present.
6. Alimentary canal 'U' shaped.

Examples: *Enoploura*, *Denrocystites*.

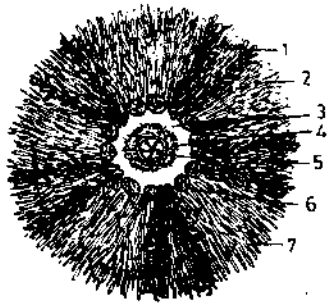

A

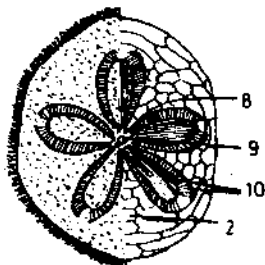

B

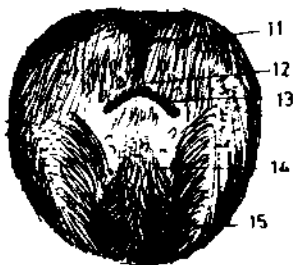

C

Fig. 22.2 Echinoderms

A. *Echinus*. B. *Clypeaster rosaceus*

C. *Echinocardium cordatum*

1. Ambulacrae
2. Inter ambulacra
3. Peristome
4. Oral tentacles
5. Teeth
6. Branchiae
7. Spines
8. Gonopore
9. Madreporic plate
10. Petaloid ambulacra
11. Modified anterior ambulacrum
12. Peristomial membrane
13. Mouth
14. Small ambulacral spines
15. Posterior-most inter-ambulacrum

22.4.3 Sub Phylum: Crinozoa

This sub-phylum is represented by a solitary class-Crinoidea.

i Class: Crinoidea

1. Body is made up of a central disc and five radiating bifurcating arms.

2. The dorsal aboral surface is directed downwards, while the ventral aboral surface, upwards.
 3. The feather-like flexible bifurcated arms act as organs of locomotion.
 4. Mouth and anal openings ventral.
 5. The dorsal side of the disc contains ossicles.
 6. Water vascular system comprises a ring vessel and radial vessels. The tube feet do not perform locomotion, they capture food.
 7. Sexes separate.
 8. Not economically important as they are not used for food.
- Examples: *Antedon* (Fig. 22.3) *Metacrinus*.

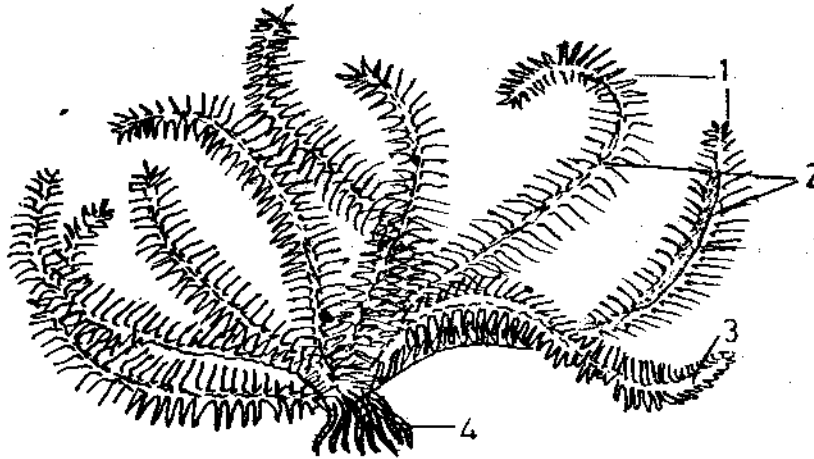

Fig. 22.3 *Antedon bifida*. 1. Pinnules 2. Ambulacral grooves 3. Arms 4. Cirri

22.4.4 Sub-Phylum: Asterozoa

This sub phylum comprises a single class viz., Stelleroidea.

i Class: Stelleroidea

1. Free-living, radially symmetrical.
 2. Body star-shaped with a central disc and five arms.
 3. Mouth is located on the oral and ventral surface, while arms situated on the aboral and dorsal surface.
 4. Two double rows of tube feet are present in the ambulacral grooves.
 5. Body cavity is lined with ciliated epithelium and is filled with coelomic fluid.
 6. Alimentary canal well developed with distinct parts.
 7. Pedicellariae present.
 8. Sense organs in the shape of sensory tentacle and eye spot.
 9. Sexes separate with evolutionary important larvae.
- Examples: *Asterias*, *Ophiothrix* (Fig. 22.4 A), *Solaster* (Fig. 22.4 B)

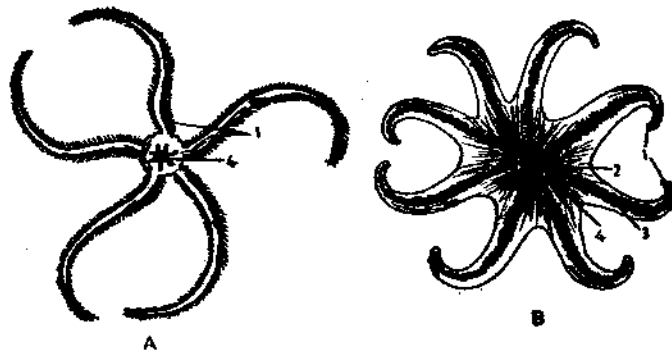

Fig. 22.4 Echinoderms. A. *Ophiothrix*. B. *Solaster*. 1. Arms. 2. Mouth. 3. Marginal plates. 4. Disc.

Check Your Progress

1. Echinoderms whose surface of the body consists of all direction movable spines are included in class
2. Watervascular system performs and functions.
3. Bifurcated arms are present in class.

22.5 SUMMARY

Echinodermata is a very well developed invertebrate. They are spiny - skinned animals, with an exoskeleton of spines. Body is typically pentamerous. A unique water vascular system is present performing locomotion. The physiology is well developed. Indirect development with different larvae in different classes. Phylum Echinodermata consists of seven classes, of which a few have become extinct.

All the representatives of different classes are bottom dwellers.

22.6 CHECK YOUR PROGRESS — MODEL ANSWERS

1. Echinoidea
2. locomotory and respiratory
3. Crinoidea

22.7 MODEL EXAMINATION QUESTIONS

I. Answer the following in about 30 lines

1. Enumerate the general characters of Echinodermata.
2. Classify the phylum Echinodermata with examples.

II. Answer the following in about 10 lines

1. Holothuroidea 2. Echinoidea 3. Crinoidea

BRAOU

UNIT-23 ASTERIAS

Contents

- 23.1 Objectives
- 23.2 Introduction
- 23.3 External Characters
 - 23.3.1 Oral surface
 - 23.3.2 Aboral surface
 - 23.3.3 Body wall
- 23.4 Endoskeleton
- 23.5 Coelom
- 23.6 Digestive System
 - 23.6.1 Alimentary canal
 - 23.6.2 Digestive glands.
- 23.7 Water Vascular System
- 23.8 Haemal System
- 23.9 Perihaemal System
- 23.10 Respiratory System
- 23.11 Excretion
- 23.12 Reproductive System
- 23.13 Summary
- 23.14 Check Your Progress — Model Answers
- 23.15 Model Examination Questions

23.1 OBJECTIVES

This unit describes a detailed study of *Asterias* (star fish) a typical representative of phylum Echinodermata. It also deals in a detail the structure, body wall, water vascular system, alimentary canal, haemal system, respiration, excretion and reproduction. At the end you will be in a position to explain the concept of radial symmetry, mesodermal origin of internal skeleton of calcareous ossicles and larval bilateral symmetry.

23.2 INTRODUCTION

Asterias is the most common and widely distributed echinoderm. It is commonly known as star fish or sea - star because of its star shaped body.

Habitat: They are the bottom dwelling animals or benthic. They are abundantly found in hard rocky areas, creeping slowly in shallow water, on the floor of the sea bottom with the help of their tube feet where locomotion and concealment are easier.

Habits: It is a **carnivorous** and nocturnal animal. Its body can be twisted in a variety of ways in spite of its hard integument. It either lives singly or in large aggregations. It has a great power of **regeneration** and **autotomy**.

Classification:

Phylum	-	Echinodermata
Sub-phylum	-	Asterozoa
Class	-	Stelleroidea
Sub-class	-	Asteroidea
Order	-	Forcipulata
Family	-	Asteridae

Sub-family - Asterlinae
 Genus - *Asterias*
 Species - *rubens*

23.3 EXTERNAL CHARACTERS

The external structure of star-fish can be studied by observing the lower and the upper surface which are respectively known as the oral and the aboral surface.

23.3.1 Oral surface

It is the flat lower surface facing the substratum. It is also known as the actinal surface (Fig. 23.1.B). The following structures are found on the oral surface.

Mouth: It is also known as actinosome. It is five rayed or pentagonal aperture. A soft membrane, the peristomal membrane surrounds the mouth. It is guarded by five sets of oral spines.

Ambulacral grooves: They are five narrow grooves radiating from the five angles of the actinosome and extending up to the tip of each arm. Each groove is provided with two rows of tube feet.

Ambulacral spines: They are short, stout projections of the calcareous plates called the ossicles. They are found in a set fashion on the oral surface. Two or three rows of movable spines, the ambulacral spines are present along the border of each ambulacral groove. These rows of immovable spines are present at the outer sides of the ambulacral spines. One row of spines are also present at the borders of each arm.

Tube feet or Podia: They are tubular and retractile. Two double rows of tube feet are found in each ambulacral groove. They are the organs of locomotion and respiration.

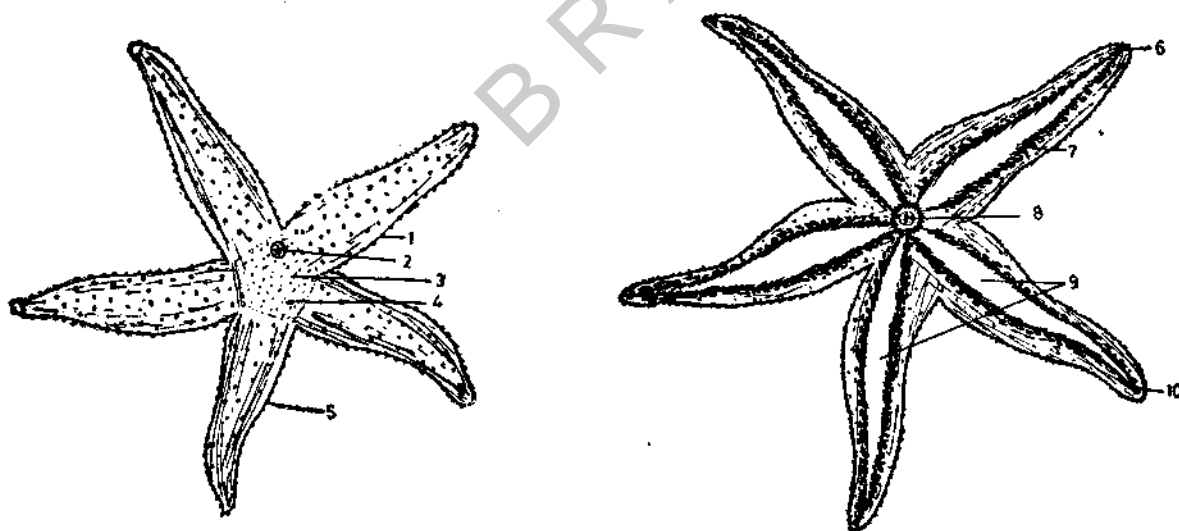

Fig. 23.1 - *Asterias* - External features. A. Aboral view. B. Oral view. 1. Marginal spines. 2. Madreporite. 3. Central disc. 4. Anus. 5. Arms. 6. Olfactory tentacle. 7. Tube feet. 8. Mouth. 9. Ambulacral grooves. 10. Eye.

Sense Organs: There are five non retractile olfactory tentacles. They are located at the end of each arm. They are olfactory and tactile in function, and help in capturing the food. At the base of each tentacle an eye is present. Eyes are small, bright red specks, sensitive to light

23.3.2 Aboral Surface

It is the upper surface possessing the following parts:

Spines or tubercles: They are calcareous and immovable. They are not arranged regularly. Like the oral spines, they are supported by ossicles (Fig. 23.1 A)

Papulae or Dermal branchiae or Dermal gills: They are found between the ossicle. They are small soft, hollow, finger like or thread like (Fig. 23.2A) and are retractile. They are organs of respiration and excretion.

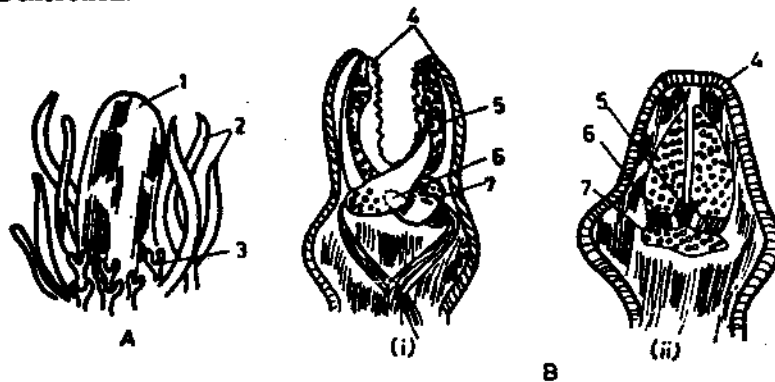

Fig. 23.2 Star fish. A Cluster of pedicellariae, papulae and tuberculae. B. Pedicellaria - (i) Closed type. (ii) Straight type
1. Tubercle or spine 2. Papulae. 3. Pedicellaria. 4. Valves. 5. Adductor muscle. 6. Abductor muscle. 7. Basal piece.

Anus: It is a small opening, situated in the middle of the aboral surface. The dorsal position of anus is characteristic of Echinodermata.

Madreporite: It is small, flat slightly projected and sieve-like porous plate. The water enters into the body and into the water vascular system through this aperture. It is located between two arms, which are named **bivium**, whereas the remaining three arms are called **trivium**.

In addition to all the above mentioned structures found on the oral and the aboral surfaces, other important structures present on both the surfaces. They are called **pedicellariae**.

Pedicellariae: They are modified spines found scattered on both the surfaces in the spaces between the spines. They possess the following characters. They are pincer-like, short and flexible. The pedicellaria is made up of a flexible stalk and three calcareous plates. One plate is basal, the basilar plate, and the other two are movable like the jaw. The jaws open by adductor muscles and close by the help of abductor muscles. Pedicellaria with three plates, found in starfish, are called forcipulate type (Fig. 23.2 B). They remove debris and waste matters settling on the body, facilitating respiration. They also protect the delicate papulae.

Types of pedicellariae: According to the nature of the two plates or jaws, the pedicellariae are of two types.

i) **Straight type or forceps:** The jaws are straight and are attached to the basilar plate. They remain parallel to one another, like the two pieces of forceps, when closed.

ii) **Crossed type or scissors:** The jaws are curved and when closed cross each other like scissors.

23.3.3 Body wall

The structure of the body wall can be studied by taking its vertical section or longitudinal section. It comprises the following layers.

Cuticle: It is the outer most thin two layered.

Epidermis: It lies beneath the cuticle. It is of ciliated epithelium. It extends over all the external structures like the spines, pedicellariae, etc. Different types of cells are found in the epidermis. They are the spindle shaped neurosensory cells, the pigment granules and club-shaped gland cells. The pigment cells impart colour to the starfish, while the gland cells secrete mucus.

Dermis or mesoderm: It is the thickest layer consisting of two regions, an outer and an inner. The calcareous plates or ossicles are secreted by the dermis.

Muscular layer: It is made up of smooth muscle fibres. It has an outer circular muscle layer and an inner longitudinal muscle layer. The muscle fibres help in the movements of the arms.

Coelomic epithelium or peritoneum: It is the inner most layer. It lines the body cavity or the coelome. It consists of flagellated cuboidal cells.

23.4 ENDOSKELETON

The endoskeleton is made up of calcareous ossicles. They render rigidity to the body of starfish. Each ossicle is made up of rod like crystalline calcite. The ossicles are united by connective tissue and muscle fibres. This results into flexibility of the body.

Different ossicles found on the body have been discussed earlier. However, a brief mention is being made here:

- i. Oral ossicles-five plates surrounding the mouth.
- ii. Ambulacral ossicles-above each ambulacral groove.
- iii. Adambulacral ossicles-at the outer margin of the ambulacral grooves.
- iv. Supra-marginal ossicles - lateral to the ad ambulacral ossicles.

23.5 COELOM

The coelom or body cavity of starfish is spacious and a true coelom. It is lined by coelomic epithelium or peritoneum, consisting of cuboidal and ciliated cells. The coelomic epithelium covering the viscera is called the visceral peritoneum and that which lines the body wall is known as the parietal peritoneum. Coelom contains visceral organs such as alimentary canal and gonads. It has many cavities, like the water-vascular system, genital sinuses, etc.

The coelom is filled with coelomic fluid and sea water. Coelomic fluid is colourless and contains many amoebocytes, coelomocytes. It bathes the tissues and carries out the function of circulation.

23.6 DIGESTIVE SYSTEM

The digestive system can be dealt under the following headings:-

23.6.1 Alimentary canal

It is a short tube extending from mouth to arms. It comprises the following parts.

1. **Mouth**-found on the oral surface. It is provided with a sphincter muscle. Mouth can be expanded and retracted.
2. **Oesophagus**-mouth leads into a short tubular oesophagus.
3. **Stomach**-it is the largest part of the alimentary canal. It has an upper cardiac stomach and a lower pyloric stomach. From the pyloric part a tube passes into each arm. It is called pyloric caeca or hepatic caeca.
4. **Intestine**-pyloric stomach opens into a short slender intestine. Two branched hollow intestinal caeca arise from the intestine.
5. **Anus**-intestine opens to exterior through anus.

23.6.2. Digestive glands

The pyloric caecae act as digestive glands. They secrete all types of enzymes, acting on proteins, carbohydrates and fats.

Food: Star fish is carnivorous. The food consists of worms, crustaceans, snails, small starfishes, and fishes. They are voracious eaters of clams and oysters.

Feeding: Food is captured by mouth, from where it enters the stomach.

Physiology of digestion The enzymes secreted by pyloric sac and caecae digest proteins, carbohydrates and fats. These food substances are converted into diffusible peptones, soluble sugars and fatty acids and glycerol.

Digestion is both extracellular and intracellular; the latter occurring in the pyloric caeca.

Absorption: Digested food is absorbed through the wall of the stomach and intestine. But the major absorption takes place in the pyloric caeca.

Assimilation: The absorbed food is distributed throughout the body by means of coelomic fluid.

Egestion: Undigested food is expelled through the mouth only. Anus egests negligible part.

23.7 WATER VASCULAR SYSTEM (Ambulacral system)

Water vascular system is a unique feature of echinoderms and a peculiarity of this group. It is derived from the coelom. It consists of the following parts.

Madreporite: As explained earlier, it is situated on the aboral surface between bivium. It is hard, rounded, button shaped, calcareous plate. It is the gateway of water into the water vascular system.

Madreporite is sieve-like, bearing many fine pores each leading into a pore canal. The pore canals unite and form collecting canals, which open into an ampulla, situated below the madreporite (Fig. 23.3)

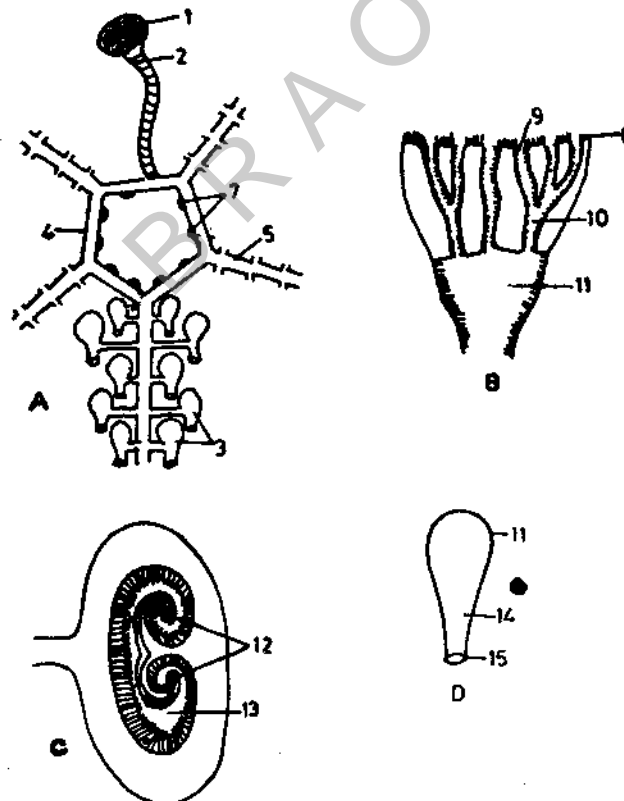

Fig. 23.3 *Asterias*. A water vascular system. B. V.S. of madreporite. C. T.S. of stone canal. D. A tube foot. 1. Madreporite 2. Stone canal 3. Tube feet 4. Ring canal 5. Radial canal 6. Transverse or lateral canal 7. Tiedmann's bodies (9) 8. Pore canal 9. Cilia 10. Collecting canal 11. Ampulla 12. Lamellae 13. Lumen of stone canal 14. Tube 15. Sucker.

Stone canal: The ampulla opens into the stone canal. It is 'S'-shaped and vertical. Its walls are supported by a series of hard **calcareous rings** which attribute to its name. The cavity of the stone canal is lined with flagellated or ciliated cells. The lumen has a projection or ridge that divided into two spirally rolled **lamellae**. An axial organ with a tubular axial sinus surrounds the stone canal.

Ring canal: Stone canal leads into a five sided, ring like canal. It runs round the oesophagus above the mouth.

Tiedmann's bodies: They are also known as **recemose glands**. They are nine yellow bodies located on the inner side of the ring canal. Their exact function is not known However, they are supposed to produce phagocytic coelomocytes.

Radial canals: The ring canal gives off from its outer side, five long ciliated slender channels called the radial canals. They extend upto the tip of the arm, and terminate with terminal tentacle.

Lateral canals or Podial canals: Each radial canal, while it runs in each arm, gives rise on either side to a series of short narrow, transverse tubes, the lateral canals or podial canals. The two limbs of the lateral canals are long and short alternately.

Tube feet or Podium: The lateral canals, described above, open into tube feet. This opening is guarded by a valve which prevents the backward flow of fluids. There are four rows of hollow elastic tube feet. Each tube foot has three parts: a terminal sucker, a medial tube and a proximal bulb or ampulla. The tube feet are provided with muscle fibres.

The entire water vascular system has muscular walls and lined internally by ciliated epithelium. The beating of cilia help in pushing the water current forward.

Course of water current: The sea water enters through the madreporite. In the madreporite it is taken in by numerous pores which open into the pore canals. The pore canals lead into ampulla, via collecting canals. Then water passes into the stone canal, from where it is transported to the pentagonal ring canal. Here it bathes the Tiedmann's bodies too. From here the water current passes to the radial canals, the lateral canals and ultimately fills the tube feet.

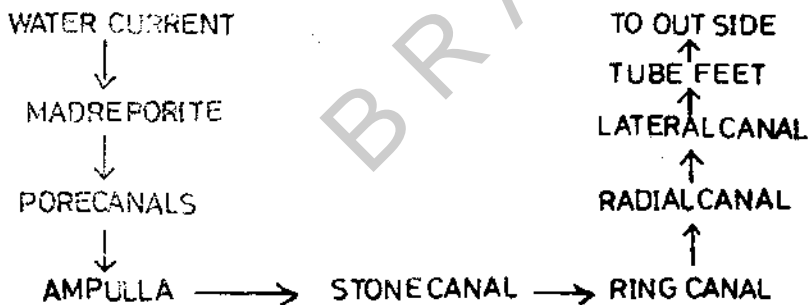

Fig. 23.4 Course of water current during water vascular system.

Functions The water vascular system is of great significance in echinoderms. Basically it performs **locomotion**. In addition to this major function, the tube feet also capture the prey and eliminate wastes by diffusion.

Locomotion: Starfish can move in any desired direction and can creep on vertical and horizontal surfaces. As said earlier, the tube feet carry out locomotion. In fact due to hydraulic pressure of the water vascular system locomotion takes place.

Different stages during locomotion are described below:

The arm, in the direction of the movement, is lifted.

The water enters through madreporite and comes finally into the ampulla.

The ampulla contract, pushing the water into tube feet.

Due to the water pressure the tube feet become extended, and attached to the substratum.

A vacuum is created by the sucker for proper attachment. It is supplemented by mucus secreted by the tips of the tube feet.

The extended tube feet push the body of the animal forward.

The muscles of tube feet contract and force back the water current which shortens the tube feet.

The suckers are released from the substratum, and the animal moves forward.

The detachment and contraction of the tube feet is repeated and the whole process goes on again and again.

Starfish shows slow forward motion. It can cover a distance of 15 cm in a minute.

23.8 HAEMAL SYSTEM

In starfish a blood vascular system is not found and true blood vessels are also absent. Instead, a transporting system of food is present, which is known as the haemal system. It is of **open or lacunar type**. It consists of an **axial gland**, an **oral haemal ring** and **aboral haemal ring**.

Axial gland: It is the central part of the system, and as such can be compared with the heart. It lies in the axial sinus. The coelomocytes contain a brown pigment (Fig. 23.5).

Aboral haemal ring: It surrounds the mouth. It sends a radial haemal sinus in each arm.

Aboral haemal ring: It communicates with the oral haemal ring through the axial gland. It gives rise to five pairs of genital haemal strands to the reproductive organs, the gonads.

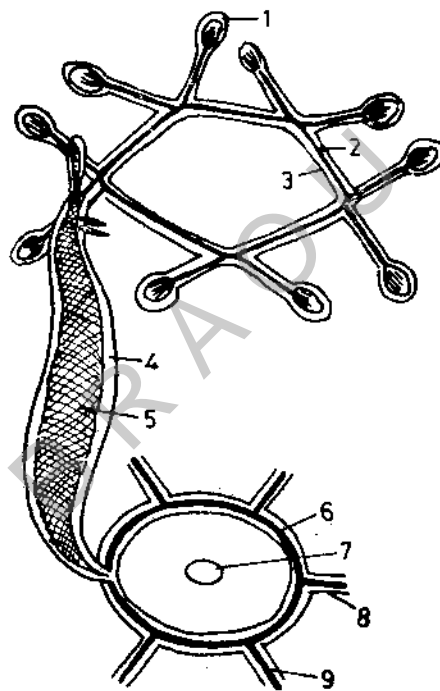

Fig. 23.3 *Asterias*-Perihaemal and Haemal system 1. Gonads 2. Aboral haemal ring 3. Aboral perihemal ring sinus 4. Axial sinus 5. Axial gland 6. Oral haemal ring 7. Mouth 8. Radial perihemal ring. 9. Radial haemal ring.

23.9 PERIHAEMAL SYSTEM

It consists of vessels and coelomic sinuses or space. Its various parts are as follows:

Axial sinus: It is a wide tube surrounding the stone canal and the axial gland.

Aboral ring sinus: It lies around the intestine. It gives rise to ten genital branches, extending towards the gonads.

Oral ring sinus: It is located around the mouth.

Radial perihemal sinus: It lies in each arm. Like oral ring sinuses it is also divided into two.

23.10 RESPIRATORY SYSTEM

Respiration is carried out by numerous dermal branchiae or papulae. The papulae are ciliated both

internally and externally. These cilia produce a respiratory current during which oxygen is drawn in and CO₂ is given out. Respiration is partly performed by the tube feet.

23.11 EXCRETION

Special organs of excretion are absent. The elimination of waste products is by amoebocytes of the coelomic fluid. The wastes are carried to the dermal branchiae, skin and tube feet, which discharge them.

23.12 REPRODUCTIVE SYSTEM

Sexes are separate without sexual dimorphism, which appears only during breeding season. Organs of reproduction are not permanent. They are very simple. They lack organs of copulation, accessory glands and reservoirs of ova and sperms. The gonads are five pairs of testes and ovaries lying freely in the proximal part of each arm between the pyloric caeca and the ampullae.

Each gonad is branched resembling a feathery tuft. When the gonads mature, they occupy the complete perivisceral space. The gonads have short ciliated gonoducts, which open laterally through a small gonopore on the oral surface.

The gonads are enclosed in genital sacs. When the gonads mature, gametes (sperms and ova) are discharged in the sea water.

Fertilization: Fertilization is external in the sea water. Breeding is annual, in spring. The fertilized egg undergoes development. Development and structure of the larva of *Asterias* has been dealt in detail in the following lesson.

Check Your Progress

1. *Asterias* possesses a peculiar water vascular system which develops from
2. Really the function of perihemal and haemal systems, is but transport of food is believed to be done by system.
3. In spite of a higher organisation the following two systems are conspicuously absent in *Asterias* and

23.13 SUMMARY

Asterias or the Star fish has five arms. The body has two surfaces, oral and aboral. Spines and other structures are present on the oral and aboral surfaces. The body wall has five layers. The endoskeleton is of calcareous ossicles. Alimentary canal is well developed, digestion is both extracellular and intra-cellular. The water vascular system, which performs locomotion is well developed. A substitute of blood vascular system is present in the form of a haemal and perihemal system. Respiration is carried out by dermal branchiae. No special organs of excretion. Sense organs not well developed.

23.14 CHECK YOUR PROGRESS — MODEL ANSWERS

1. coelom
2. unknown; haemal
3. excretory, circulatory.

23.15 MODEL EXAMINATION QUESTIONS

1. Answer the following in about 30 lines
 1. Write the external characters of *Asterias*.
 2. Describe the digestive system of Starfish.
 3. Give an account of water vascular system of *Asterias*
 4. Describe how the locomotion is carried out in *Asterias*
- II. Answer the following in about 10 lines
 1. Haemal system
 2. Nervous system
 3. Pedicellariae
 4. Body wall.

UNIT-24 ECHINODERM LARVAE

Contents

- 24.1 Objectives
- 24.2 Introduction
- 24.3 Development of Asterias.
 - 24.3.1 Dipleurula larva or early bipinnaria
 - 24.3.2 Bipinnaria larva
 - 24.3.3 Branchiolaria larva
- 24.3.4 Significance of Bipinnaria larva
- 24.4 Ophiopluteus Larva
- 24.5 Echinopluteus Larva
- 24.6 Auricularia Larva
- 24.7 Doliolaria Larva
- 24.8 Fate of Echinoderm Larvae
- 24.9 Significance of Echinoderm Larvae
- 24.10 Summary
- 24.11 Check Your Progress - Model Answers
- 24.12 Model Examination Questions
- 24.13 Glossary

24.1 OBJECTIVES

This unit is about the different types of larvae found in Echinodermata. It gives an account of their structure and relationship with other groups. At the end you will be in a position to explain the fundamental similarities in the larvae leading to their common origin. Further you can throw light on how bilateral larval symmetry is affected due to metamorphosis transforming the larvae into radially symmetrical ones.

24.2 INTRODUCTION

Echinoderms exhibit different larval forms like class Crustacea of phylum Arthropoda. The different classes of this phylum show different free swimming larvae. The larval forms are observed during indirect development only. The larvae appear after series of changes initiated by the development. The various stages of development and pre-larval stages have already been studied in the development of starfish. However, a brief account of the development of Asterias is necessary, before we deal with the various larval forms.

24.3 DEVELOPMENT OF ASTERIAS

Asterias is unisexual and the fertilization is external in the seawater. The fertilized egg or the zygote undergoes embryonic development initiated by cleavage or segmentation. Segmentation is **holoblastic, equal and indeterminate** i.e., the fate of the blastomeres is not fixed. After 24 hours of segmentation a single layered, hollow, spherical, and ciliated embryo is formed. It is called the **blastula**. Its cavity, the blastocoel, is filled with a fluid. Blastula swims about with the help of its cilia. Further development transforms one layered, ciliated blastula into a two layered ciliated **gastrula**. It is elongated with a central cavity called the gastrocoel or archenteron, which opens to the exterior by a wide tube called the blastopore. The two layers of the gastrula are the ectoderm and the endoderm. The larval mouth is formed on the anterior ventral side, while the blastopore becomes the larval anus. The third layer, the mesoderm, is developed by the budded off cells of the endoderm. Now the embryo becomes triploblastic, possessing all the three germinal layers, i.e., the

ectoderm, endoderm and mesoderm (Fig. 24.1). The archenteron now gets differentiated into a proximal part and a terminal part. The former gives rise to oesophagus, stomach and intestine; and the later to two coelomic sacs. The coelomic sacs develop into coelom. The cilia now occupy definite regions of the embryo. Two ciliary bands appear. One of the perioral band surrounding the mouth and the other aboral band, lying inside the mouth. The triploblastic embryo slowly changes into free-swimming larva.

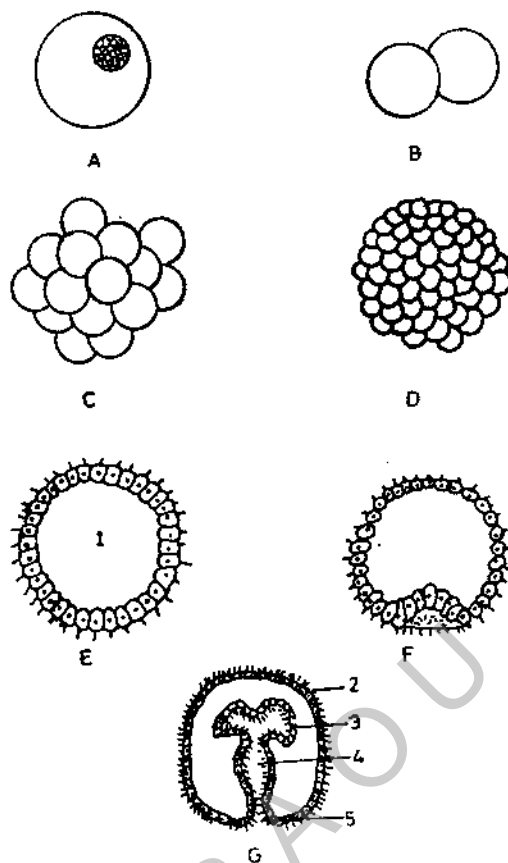

Fig. 24.1 *Asterias*-Segmentation. A. Fertilized egg. B. 2 Blastomeres. C. 16 Blastomeres. D. Blastula. E. V.S. Blastula. F. V.S. of early gastrula. G. V.S. of gastrula. 1. Blastocoel. 2. Ectoderm. 3. Endoderm. 4. Archenteron. 5. Blastopore.

The early larval stage is bilaterally symmetrical and is termed dipleurula larva. It is the fundamental larva which gives rise to different larval forms in Echinodermata. The characteristic water vascular system arises from the coelomic sacs.

In class Asterozoa one larval stage gives rise to another, whereas in all other classes specific larval types are present. **Special features of the echinoderm larvae are:**

Bilateral symmetry, which is quite contrary to the radial symmetry of the adult forms.

Presence of varying numbers of ciliated bands, meant for swimming.

Presence of a complete alimentary canal.

Arms, morphologically different from adults, are found.

The larvae differ in shape in different classes.

The number and arrangement of the arms and ciliated bands also differ.

Now the various larval forms met in each class are being discussed.

24.3.1 Dipleurula larva or early Bipinnaria

1. It is the basic larval form of phylum Echinodermata.
2. It results after the embryonic development.
3. It is bilaterally symmetrical, swimming with its anterior end forward.
4. It feeds on unicellular organisms.
5. There is a tuft of apical cilia on the apex.

6. A peri oral ciliary band surrounds the mouth. It is locomotors in function.
7. Another ciliated band is found inside the mouth. It is known as aboral band (Fig. 24 2 A)

24.3.2 Bipinnaria larva

We come across two larval forms in class Asterozoa. The first larval form is called the bipinnaria, while the latter form is known as brachiolaria.

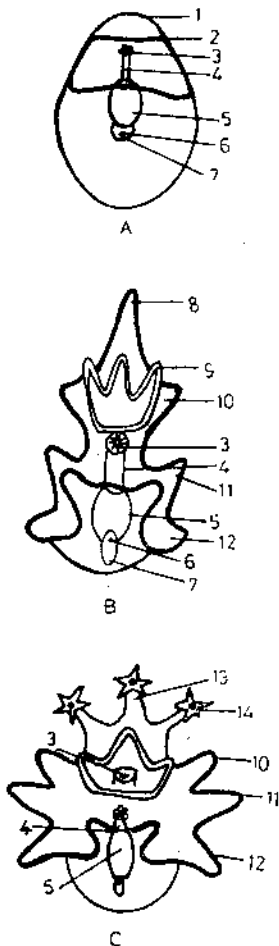

Fig. 24.2 Echinoderm larvae.

- A. Dipleurula larva
- B. Bipinnaria larva
- C. Brachiolaria larva
1. Postoral loop
2. Preoral loop
3. Mouth
4. Oesophagus
5. Stomach
6. Anus
7. Intestine
8. Median dorsal arm
9. Preoral arm
10. Antero-dorsal arm
11. Postero - dorsal arm
12. Postero - lateral
13. Median dorsal arm
14. Adhesive cells

It is a free swimming larva developed from the dipleurula larva.

It consists of different ciliated bands which cover the entire body and are named according to their location.

The anterior end of the larva enlarges from a preoral lobe. It is surrounded by the preoral band of cilia, which is completely separate from other ciliary band.

The second band is the first mentioned postoral band. It is found around the body.

An aboral band of cilia is present in the mouth.

There are three lateral lobes or projections, bordered by ciliary bands.

There are different sets of arms, known by their positions. There are a **median dorsal arm** a pair of **preoral arms**, **anterior dorsal arms**, **posterior dorsal arms**, **post oral arms** and **postero-lateral arms**. Alimentary canal consists of mouth, oesophagus, stomach, intestine, and anus.

The coelom is 'U' shaped.

10. It remains in this stage for a few weeks and then transforms into Brachiolaria larva (Fig. 24.3 B)

24.3.3 Brachiolaria larva

It is more complicated in shape and structure than the bipinnaria larva.

In addition to the already existing arms, three short arms are supplemented to the preoral lobe.

These arms are called the brachiolar arms. They are smaller and non-ciliated.

One of three is median and the remaining two are lateral.

They possess coelomic projections and adhesive cells at their tips. The cells form a glandular area serving like sucker for adhesion.

The side lobes become more elongated and are now designated as the larval arms. They move and contract.

After about 6-7 weeks the larva settles down and gets adhered to some solid object by means of the suckers, mentioned above.

Brachiolaria larva undergoes metamorphosis to become a radially symmetrical adult.

The five lobes develop into five arms.

Larval arms and the different ciliary bands disappear.

Larval mouth and arms close. A new mouth develops on the oral surface and a new anus on the aboral side (Fig. 24.2C)

24.3.4 Significance of Bipinnaria larva

The bipinnaria larva of class Asterozoa is of significant importance from the evolutionary point. At the same time it corresponds to the other larval forms found in other classes of Echinodermata. It resembles the pluteus larva of the classes Ophiurozoa and Echinozoa, and also the auricularia larva of the class Holothurozoa.

In addition to its resemblances with the larvae of its own phylum the larva has got relationship with the larvae of other groups, both lower and higher. It presents close and striking resemblances to the trochophore larva of some flatworms, annelids (*Nereis*) and molluscs. Further, bipinnaria also bears similarities with the tornaria larva of Hemichordata (*Balanoglossus*). This shows phylogenetic affinity of Echinodermata with other groups.

24.4 OPHIOPLUTEUS LARVA

1. It is the typical larva of class Ophiurozoa.
2. It is a free-swimming larva
3. The preoral lobe is small.
4. There is a single ciliated band supported by calcareous rods, as against two in the bipinnaria larva.
5. Though the arms are fewer in number, the posterolateral arms are the largest and projected forwards. They give a 'V' shaped appearance to the larva.
6. The other arms are anterolateral, postoral, and posterodorsal.
7. Coelomic chambers and archenteron are found inside the larva.
8. The suckers at the tips of the arms are lacking.
9. Alimentary canal has a mouth, oesophagus, stomach, intestine, and an anus.
10. During metamorphosis, the larva does not get attached but sinks to the bottom and becomes an adult (Fig. 24.3 A).

24.5 ECHINOPLUTEUS LARVA

1. The larva of class Echinozoa is known as echinopluteus.
2. It resembles the ophiopluteus larva in possessing a small preoral lobe and a single ciliated band.
3. The difference is that the anterolateral arms are dissimilar. They are very short and directed backwards.

The other arms are preoral, anterodorsal, postoral and posterodorsal. Posterolateral arms are usually absent.

In cases where anterodorsal arms do not appear, the larva possesses only four pairs.

The arms are provided with pigmented tips and are supported by calcareous rods.

Alimentary canal is with the usual parts (Fig. 24.3 B)

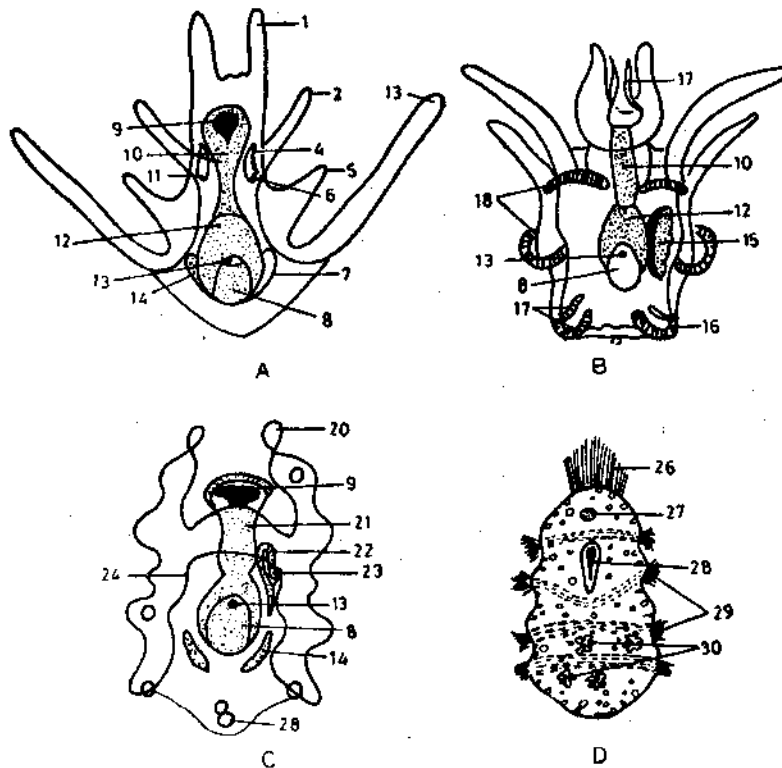

Fig. 24.3 Echinoderm larvae. A. *Ophiopluteus larva* B. *Echinopluteus larva* C. *Auricularia larva* D. *Doliolaria larva*. 1. Antero lateral arm 2. Postoral arm. 3. Postero lateral arm. 4. Left axocoel. 5. Postero dorsal arm 6. Left hydrocoel with lobes 7. Left somatocoel 8. Intestine 9. Mouth 10. Oesophagus 11. Right axo-hydrocoel 12. Stomach 13. Anus 14. Right somatocoel 15. Echinus rudiment 16. Postero lateral process 17. Posterior epaulettes 18. Anterior epaulettes 19. Preoral arm 20. Preoral lobe 21. Pharynx 22. Hydrocoel 23. Hydropore 24. Anal loop 25. Ossicle 26. Apical sensory tube 27. Adhesive pit 28. Vestibule 29. Ciliary rings 30. Basals.

24.6 AURICULARIA LARVA

Class *Holothuroidea* has evolutionary significant larva called *auricularia*.

It is one of the most primitive larval forms.

It is pelagic.

It is an elongated larva measuring 0.5 to 1.00 mm in length.

The ciliated band is found partly around the preoral lobe and partly around and anus. The former is called preoral loop and the latter anal loop. These are the organs of swimming.

A number of short processes develop.

The alimentary canal is curved.

Auricularia develops into the next larval form, the *doliolaria*.

Doliolaria is barrel shaped, transformed from the *auricularia*. It resembles a *crinoid larva*.

The ciliated band breaks into 3-5 flagellated rings.

The mouth and anus come to lie on the anterior and posterior poles respectively.

During the course of metamorphosis 5 tentacles and 1-2 podia are developed (Fig. 24.3C)

24.7 DOLIOLARIA LARVA

1. The larva of class *Crinoidea* is termed *doliolaria*.
2. It is free swimming.
3. Anteriorly an apical plate with tuft of sensory cilia is present.
4. Below the apical plate mid-ventrally an adhesive pit is found.
5. There are four other ciliary bands.
6. Vestibule is present between the second and the third ciliary bands.

24.8 FATE OF ECHINODERM LARVAE

All the echinoderm larvae undergo metamorphosis to become adult. Bilateral larvae, i.e. pluteus, bipinnaria and brachiolaria change to radial adults. During this process the larval arms are absorbed. In auricularia and ophiopluteus all the larval organs are continued on into the adult. The mouth and oesophagus of the bipinnaria and doliolaria disappear giving place to new mouth and oesophagus. Doliolaria is the only larva which becomes sedentary.

24.9 SIGNIFICANCE OF ECHINODERM LARVAE

We have already discussed the importance of the bipinnaria larva. Here the evolutionary significance of other larvae are being highlighted. Of all the larvae auricularia bears striking resemblances to the tornaria larva of *Balanoglossus*, a hemichordate. Because of this Muller had placed tornaria larva along with the bipinnaria and auricularia. The course of longitudinal ciliated band is similar in both the larvae, as well as in the earlier described bipinnaria. The pelagic nature and the transparent body are the other similarities.

The apical plate found in the dipleurula larva, the basic larval form of Echinodermata and in doliolaria larva is similar to that of the tornaria.

After observing different above mentioned similarities and closeness of the echinoderm larvae to the larvae of hemichordata, annelida and mollusca (trochophore), it can be concluded that echinoderms are the ancestors of hemichordates.

Check your progress

1. The name of the supposed larva, which is considered to be common ancestor of echinoderms is
 2. Bipinnaria transforms into larva and then undergoes
 3. Striking similarities between Bipinnaria, Auricularia and Tornaria suggest a common of echinodermata and Hemichordata.
-

24.10 SUMMARY

Different classes of phylum Echinodermata exhibit different larval forms.

Each class is marked with its typical larva.

Bipinnaria is the larva of Asterozoa, ophiopluteus belongs to class Ophiurozoa, echinopluteus is of Echinozoa, auricularia is the larval form of Holothurozoa, and doliolaria is that of Crinozoa. Bipinnaria, auricularia and doliolaria bear many similarities with the tornaria larva of *Balanoglossus* and the trochophore larva of annelids.

The larvae are of evolutionary significance.

24.11 CHECK YOUR PROGRESS — MODEL ANSWERS

1. Dipleurula
 2. Brachiolaria, metamorphosis
 3. phylogeny
-

24.12 MODEL EXAMINATION QUESTION

I. Answer the following in about 30 lines.

1. Give an account of development of *Asterias*.
2. Describe the structure and significance of bipinnaria larva.
3. Give a brief account of larvae found in Echinodermata. What is their evolutionary importance.

II. Answer the following in about 10 lines

1. Dipleurula 2. Bipinnaria 3. Brachiolaria 4. Ophiopluteus 5. Echinopluteus 6. Auricularia 7. Significance of echinoderm larvae in general.

24.13 GLOSSARY

Abductor muscle	:	A muscle which pulls a part away from the main axis of the body
Accessory glands	:	Additional glands helping in a particular system
Adductor muscle	:	A muscle which pulls a part towards the main axis of the body
Amoebocytes	:	Cells with amoeboid properties i.e. moving and feeding by the action of pseudopodia
Benthic	:	Animals that inhabit the bottom of the sea
Bilateral	:	Having two sides
Brackish	:	Slightly salty
Calcareous	:	Made up of calcium
Carnivorous	:	(C. Caro: flesh; vorare: to devour) Flesh eating
Ciliated epithelium	:	A layer of cells bearing cilia
Cleavage	:	The repeated division of a fertilized ovum along definite planes
Copulatory organs	:	An organ such as penis which enables the male animal to discharge seminal fluid into the vagina or oviduct of the female
Debris	:	A mass of rubbish fragments
Dioecious	:	Having separate sexes
Enterocoelus	:	Animals with a coelom which has been in communication with the archenteron, in the embryonic stages.
Enzyme	:	A secretion which accelerates a chemical action
Extracellular	:	Occuring outside the cell
Fertilization	:	The union of male and female gametes
Gonoduct	:	Genital duct leading from gonad to exterior
Holoblastic	:	Complete cleavage of a fertilized ovum
Indirect development	:	A development marked with larval stage
Intracellular	:	Occuring inside the cell
Metamorphosis	:	A rapid and complete transformation from larval to an adult form.
Nephridium	:	A primitive excretory organ
Olfactory	:	Connected with the sense of smell
Oyster	:	A mollusc
Peritoneum	:	A membrane lining the body cavity
Peduncle	:	A short stalk bearing an organ or a sessile organism.
Phagocyte	:	A type of white blood corpuscle able to engulf foreign bodies
Retractile	:	That may be drawn back
Sexual dimorphism	:	A state in which males and females have a distinctly different appearance, structure or size.
Statocyst	:	An organ of balance
Tactile	:	Connected with sense of touch

UNIT - 25 EVOLUTIONARY TRENDS IN INVERTEBRATES

Contents

- 25.1 Objectives
- 25.2 Introduction
- 25.3 Protozoa
- 25.4 Metazoa
 - 25.4.1 Diploblastic animals
 - 25.4.2 Triploblastic animals
- 25.5 Symmetry
- 25.6 Coelom
- 25.7 Metameric Segmentation
- 25.8 Cephalization
- 25.9 Summary
- 25.10 Check Your Progress — Model Answers
- 25.11 Model Examination Questions

25.1 OBJECTIVES

To trace the origin of Metazoa and consequent evolutionary significance with special reference to symmetry, coelom formation, metameric segmentation and cephalization. Through study of this unit will equip you to explain not only the systematic organisation of animal kingdom but also step by step progress of evolution by minor variations.

25.2 INTRODUCTION

All the living organisms in the earlier times have been classified into prokaryotes and the four eukaryote kingdoms, namely, protistans, metaphytes, fungi and metazoans. Protistans and metazoans are included in the Animal Kingdom while Fungi and metaphytes are included in the Plant Kingdom. Let us here confine our study to Animal Kingdom only.

25.3 PROTOZOA

The Animal kingdom is divided into two subkingdoms called Protozoa and Metazoa. The Protozoa were formerly referred to as unicellular. Now these are referred to as unicellular (Dobell). Protozoa are microscopic in size. The organisation is simple. The different parts (organelles) of these protozoans are specialised for various functions. These also form colonies of many similar members (*Volvox*, *Protospongia*). The members of a protozoan colony are functionally independent of one another.

25.4 METAZOA

The Metazoa are believed to have been evolved by colony formation (Haeckel). The general theory of Hadzi, a Yugoslavian Zoologist claims that the Metazoa arose by a cellularization of a multinucleate ciliate. Phylum Porifera among metazoans differ widely from the remaining groups and justifiably have evolved separately. The Porifera treated as Parazoa retained the cellular grade of organization. Metazoans are animals in which the tissue grade of organization has reached its fullest expression. The organs are composed of several types of tissues. All these function in co-ordination with one another. In view of the variety of organs and the different types of tissues it is difficult to give an accurate definition of a metazoan. However a reasonable generalisation is as follows:

These animals have a gut with a mouth.

Primitive metazoans are without anus.

Muscular tissues are in sheets in lower metazoans and in blocks and layers in higher metazoans.

Nervous tissue with nerve fibres and ganglia.

In spite of the wide variations found among the metazoans, the group is divided into two, the **diploblastica** and the **Triploblastica**. The diploblastic animals have two layers of cells. Animals having three layers are included in the **triploblastic** group. These layers are considered as the primary germ layers. All the organs and organ systems are developed from these layers.

25.4.1 Diploblastic animals

The diploblastic condition is the simpler one. It is also considered as primitive.

This condition is found in Cnidaria (Coelenterate) and Ctenophora.

The body is composed of two layers, the ectoderm and the endoderm.

Mesoglea, a structureless gelatinous layer lies in between the ectoderm and endoderm.

Anus is absent.

The endoderm lines the digestive cavity.

The ectoderm forms the protective covering and also contains sensory organs.

25.4.2 Triploblastic animals

1. All the other animals are included in **triploblastic**
2. Besides the ectoderm and endoderm, there is a third layer called the mesoderm. This layer replaces the mesoglea.
3. **Platyhelminthes** are the first triploblastic animals in which the digestive tract is still without anus. The subsequent evolution, however, led to the formation of a fully formed gut giving the entire body a tube-within a tube plan.
4. Apart from the three layered condition, the major evolutionary trends of triploblastic animals include i) origin of bilateral symmetry ii) formation of coelom and iii) metameric segmentation of the body. These three phenomena have contributed for further evolution of organ systems, regionalisation of body etc.

25.5 SYMMETRY

Symmetry is the division into equal parts by lines of planes. There are four possible types of symmetrical patterns. All the animals show any of these types of symmetry radial symmetry, bilateral symmetry, spherical symmetry and asymmetry are the four types of symmetry.

Radial symmetry: Phyla Porifera, Cnidaria and Ctenophora exhibit this symmetry. Radial symmetry is considered to be the primitive. These animals sometimes are grouped together as the **Radiata**. Many species of these groups have become irregular as in sponges. A few have become biradial such as sea-anemones and Ctenophora. The primitive symmetry in these animals also is radial symmetry.

Bilateral Symmetry: All of the remaining animal phyla are bilateral termed as **Bilateria**. The radial symmetry observed in Echinodermata is secondarily. It is derived from the embryonic bilaterality. Organ systems are present and the mesoderm is well developed. The Bilateria are divided into two major divisions the **Protostomia** and the **Deuterostomia**. This division is based on the mode of formation of mouth during embryological development. In protostomes the blastopore or an opening close to it becomes the mouth, whereas in deuterostomes it arises from a site which is away from the blastopore.

The **Protostomia** includes animals belonging to various groups of invertebrates from Platyhelminthes to Arthropoda and Mollusca. Echinodermata among invertebrates comes under Deuterostomia. The three major phyla Annelida, Arthropoda and Mollusca are closely related ancestrally. They are also believed to have a common ancestor resembling the present day Platyhelminthes. The only group Aschelminthes is somewhat peculiar among the Protostomia. The

seven classes of Aschelminthes are heterogeneous. The Protostomia have the following characters:

The mouth is derived from the embryonic blastopore.

A well developed stomodaeum is present.

Embryonic development is of the determinate type.

Cleavage is of the spiral type.

A larval form is usually present in development.

The mesoderm originates by the solid ingrowth of cells from the endoderm.

The coelom when formed is not an enterocoel.

The Deuterostomia on the other hand is a more heterogeneous group. This includes chordates. Peculiarly Echinodermata which is an invertebrate phylum also shares many of the characters of deuterostomes. It was suggested that a dipleural type larva (hypothetical larva of echinoderms) was the ancestor for the chordate-line of evolution (Hyman, 1940). The Deuterostomia has the following characters:

Blastopore becomes the anus or the anus forms where the blastopore closed.

The mouth is a new formation.

The cleavage is of the indeterminate type.

The mesoderm and coelom originate by the outfolding of the gut wall. This is by the enterocoelous method.

One of the significant development of the bilateral symmetry is the formation of head, known as cephalization. This has started in Platyhelminthes itself, but it attained its distinctness in annelids and arthropods where metameric segmentation also becomes characteristic.

25.6 COELOM

The evolution of a secondary body cavity is considered to be of major importance in metazoan

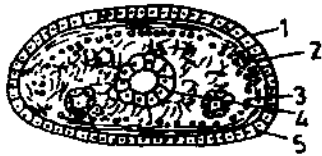

A

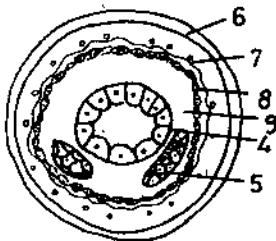

B

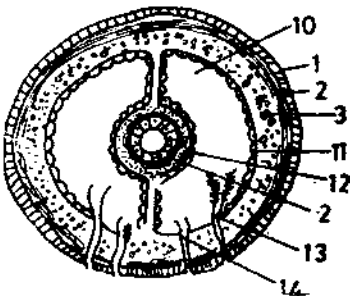

Fig. 25.1 Diagrams to show the evolution of coelom in Bilateria.

- A. Acoelomate with out body cavity
- B. Pseudocoelomate
- C. True coelomate
- 1. Epidermis
- 2. Circular muscles
- 3. Longitudinal muscles
- 4. Intestine
- 5. Gonad
- 6. Cuticle
- 7. Syncytial epidermis
- 8. Muscles
- 9. Pseudocoelom
- 10. True coelom
- 11. Parietal coelomic epithelium
- 12. Visceral coelomic epithelium
- 13. Metanephridia
- 14. Gonoduct

evolution. It is also an essential prerequisite to the development of greater size and complexity. The coelom is defined as a liquid-filled cavity in the mesoderm. It develops from the embryonic mesoderm. The cavity is lined on either side by the mesodermal lining. The lining which encloses the gut and viscera is called the **visceral peritoneum**, whereas the one which lines the interior of body wall is called the **parietal peritoneum** (Fig. 25.1C) Based on the coelom structure the Bilateria is divided into three major groups (Fig. 25.1)

1. **Acoelomata:** The region between the digestive tract and the epidermis is completely filled with mesenchyme and muscle fibres. There is no body space. This type is met with in phylum Platyhelminthes.
2. **Pseudocoelomata:** This body space is not a true coelom. Animals belonging to phylum Aschelminthes possess a body cavity of this type.
3. **Coelomata:** The body space is a true coelom. The remaining phyla of the Bilateria are characterised by this type of coelom. The coelomate group can be again divided into three types. This division is based on embryological studies on the origin of entomesoderm and the coelom.

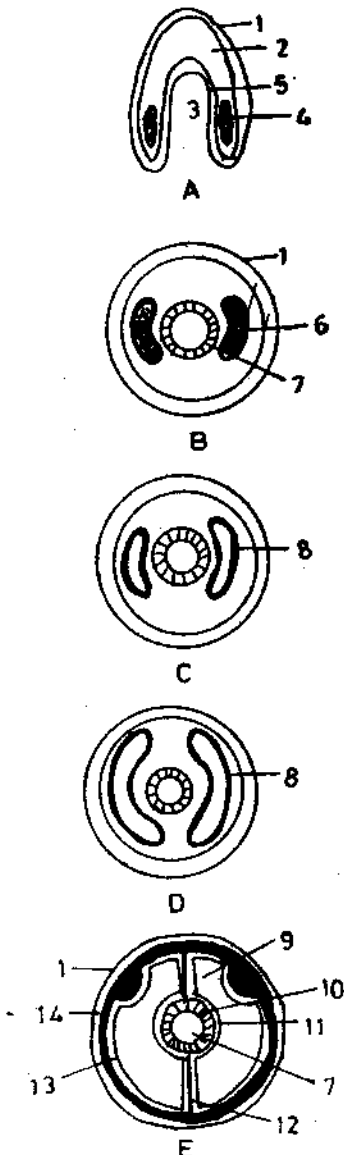

Fig. 25.2 A,E: Different stages in the development of coelom by schizocoely.

- A. Section of a gastrula
- B. Section of adult coelomate
1. Ectoderm
2. Blastocoel
3. Archenteron
4. Rudiments of the mesoderm
5. Developing endoderm
6. Mesoderm
7. Intestine
8. Developing coelom
9. Coelom
10. Endoderm
11. Visceral coelomic epithelium
12. Mesentery
13. Somatic coelomic epithelium
14. Organs of mesodermal origin.

- i. **Schizocoel:** The coelom arises from a split in the mesodermal bands, plates or masses. This is found in most of the metameric Protostomia (Fig. 25.2).

- ii. **Enterocoel:** The mesoderm primitively arises by a process called **enterocoelic pouching**. In this the wall of the archenteron evaginates to form pouches. The pouches separate from the archenteron. The pouches later differentiate into the coelom. The walls of the pouches become the mesoderm. This method of coelom formation is seen in all deuterostomes (Fig. 25.3)
- iii. **Mesenchymal:** This is an unusual method of coelom production is seen only in *Phoronida*. In this method the mesenchyme rearranges itself to enclose a space to form the coelom.

The evolution of coelom was a major advance in metazoan evolution. This becomes evident when an attempt is made to compare the acoelomates and pseudocoelomates with coelomates. There are four basic theories of the evolution of the coelom. They are:

1. Enterocoel Theory of Sedgwick (1884)
2. Gonocoel Theory of Bergh (1885)
3. Nephrocoel Theory and
4. Schizocoel Theory

The **function of coelom** is considered as one of the very important evolutionary advantages. In many animals the coelom is considered as **hydraulic skeleton**. In forms where this function is not served the coelom is reduced.

In the early stages of evolution of Bilateria the animals developed musculature consisting of contractile elements. The animals were able to swim about with feeble movements. With increasing body size and musculature the animals gradually took up terrestrial mode of life. With more terrestrialsation they also developed the faculty of locomotion. By further development, a few of them became burrowing forms. In such animals the coelom served as the hydraulic skeleton. Muscle fibres also have developed well. The coelom and the coelomic fluid certainly were of greater use to these work-like burrowing animals. In the course of evolution this fluid skeleton evolved independently number of times. The coelom is polyphyletic in origin.

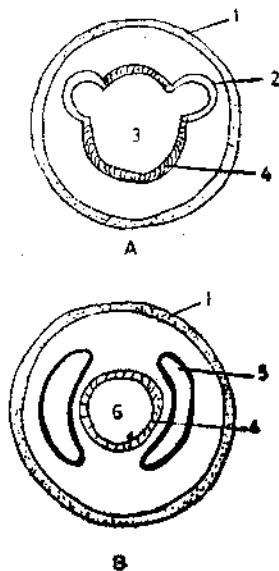

Fig. 25.3 - Mesoderm giving origin to coelom by enterocoelic method. A. Formation of enterocoelic pouches. B. Differentiation of the pouches into mesoderm and later development into coelom. 1. Ectoderm 2. Evagination of the gut to form the enterocoelic pouch 3. Archenteron 4. Endoderm 5. Mesoderm forming the coelom 6. Gut.

25.7 METAMERIC SEGMENTATION

Segmentation in animals involves the longitudinal division of the body into serial sections. Each section typically having a pair of some or all of the various organ units. The terms metamerism and metameric segmentation applies only to the organs derived from the mesoderm. If the segmentation is superficial it is known as **pseudometamerism**. Tapeworm is the example. The main theories concerning metameric segmentation are based on two aspects i) The repetition of mesodermal structure, ii) Relationship between the evolution of the coelom and evolution of metameric segmentation.

25.8 CEPHALIZATION

We have seen that metameric segmentation is one of the important evolutionary aspects in metazoans. However, this is not uniform in all the metazoans. Only the embryos of metazoans and a few adults show typical metamerism. One of the factors which affects metamerism is the specialization of the anterior end to form a head. The necessity of forming the head seems to be a consequence of the type of life led by the animals in relation to their environment. Symmetry of the animals also has certain influence on this change. radially symmetrical animals are either sessile or free floating. These require all round knowledge of the environment. Therefore, the sense organs are located peripherally. On the other hand, the situation in the bilaterally symmetrical animals is different. These animals move in a particular direction. The sense organs, therefore, are all crowded at the end that first reaches the new environment. This process is termed cephalization. This has resulted in the formation of a specialized anterior end and an antero-posterior axis.

Check Your Progress

1. Cnidaria and ctenophora which display a fundamental radial symmetry are grouped together as the
2. Schizocoelomata includes three major bilateral phyla namely the
3. Consequent to metameric segmentation and coelom formation in metazoans like burrowing annelids, a skeleton is formed.

26.9 SUMMARY

The animal kingdom is divided into Protista and Metazoa. All multicellular animals are included in Metazoa. The distinction between diploblastic and triploblastic animals explained. Symmetry in animals is discussed in detail. Bilaterally symmetrical animals are subdivided into Protostomia and Deuterostomia. Coelom and types of coelom and their formation discussed. Metameric segmentation and its evolutionary significance. Cephalization is a characteristic of most of the bilaterally symmetrical and segmented animals.

25.10 CHECK YOUR PROGRESS — MODEL ANSWERS

1. Radiata
2. Annelida, Arthropoda, Mollusca
3. Hydraulic

25.11 MODEL EXAMINATION QUESTIONS

I. Answer the following in about 30 lines

1. Discuss various types of symmetry found in animals.
2. Based on the coelom structure what are the three major groups of Bilateria. Give the examples.
3. What are the important characters of a typical Metazoan.
4. Briefly describe major evolutionary trends in triploblastic animals.

II. Answer the following in about 10 lines

1. Diploblastic animals
2. Triploblastic animals
3. Protostomia
4. Deuterostomia

BRAOU

BLOCK - II
PROTO CHORDATA

BRAOU

BRAOU

UNIT 26 PROTOCHORDATES - GENERAL CHARACTERS

Contents: CLASSIFICATION AND AFFINITIES OF SUBPHYLUM HEMICHORDATA

- 26.1 Objectives
- 26.2 Introduction
- 26.3 General Characters of Hemichordata
- 26.4 Classification
 - 26.4.1 Class - enteropneusta
 - 26.4.2 Class - Pterobranchia
- 26.5 Affinities with Chordata
- 26.6 Affinities with Echinodermata
- 26.7 Affinities with Annelida
- 26.8 Summary
- 26.9 Check Your Progress — Model Answers
- 26.10 Model Examination Questions

26.1 OBJECTIVES

This unit presents the general introduction to the Chordata, classification and systematic position of Hemichordata. At the conclusion of this you will be able to explain with great interest how the rank of this small group of worm like animals has become a Jigsaw puzzle to the zoologists till today. They are unable to decide its alliances precisely.

26.2 INTRODUCTION

The largest phylum of Deuterostomia is the chordata. They possess three distinguishing characteristics which appear atleast for sometime in their life cycle.

They are: the **notochord**, the **gill slits** and **dorsal hollow nerve cord**.

1. **Notochord or Chorda dorsalis:** It is a stiff long and elastic rod like structure. It consists of large vacuolated cells. It lies below the nerve cord and above the gut. It is axial in position. It is covered by two sheaths. The inner sheath is thick and is made up of fibrous connective tissue, outer sheath is thin and is made up of elastic connective tissue. The notochordal cells are vacuolated and are filled with semifluid substance. It causes turgidity. Notochord is endodermal in origin. In higher chordates notochords is usually replaced by a segmented **cartilaginous or bony vertebral column**. Notochord is stiff and firm. So it prevents shortening of the body. It supports the body. It helps in locomotion, and in muscle attachment. The animals which possess notochord are called chordates and the phylum is called Chordata (Fig. 26.1)

2. **Gill slits or Branchial clefts:** In all the chordates the wall of the pharynx has perforations. They develop as ectodermal invaginations and fuse with the endodermal evaginations of pharynx.

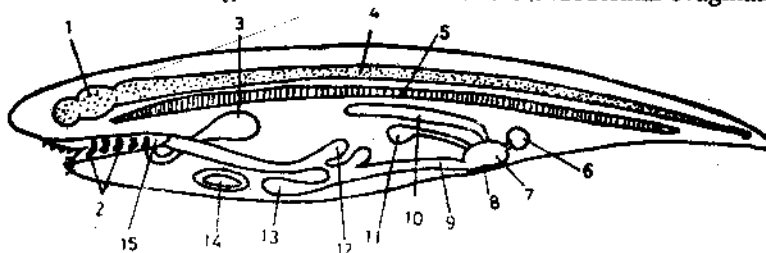

Fig. 26.1 A typical chordate (diagrammatic) 1. Brain. 2. Gill clefts. 3. Lung. 4. Nerve cord. 5. Notochord. 6. Bladder. 7. Cloaca. 8. Cloacal aperture. 9. Hindgut. 10. Kidney 11. Gonad. 12. Stomach 13. Liver 14. Pericardium with heart. 15. Pharynx.

This becomes the respiratory apparatus in the aquatic animals. In the terrestrial forms the remnants of gill slits are found. In the early embryonic condition they are found as transitory structures. In the adult vertebrates, the branchial apparatus may be modified into endocrine gland. In lowly organised chordates the branchial apparatus is used for feeding mechanism.

3. **Nerve cord:** It is dorsally situated hollow, tubular structure. It is filled with fluid. This cavity is called neurocoel. The nerve cord persists throughout life in most of the chordates. In Urochordata the larva has got the nerve cord but in the adult it degenerates. In higher chordates it is differentiated into fore brain, mid brain, hind brain and spinal cord. In non-chordates the nervous system consists of a solid double ventral nerve cord with ganglionated swellings which are metamerically arranged.

There is no general agreement regarding the most appropriate classification of phylum Chordata. According to Jeffery Parker and William A. Haswell the phylum Chordata is divided into four sub phyla.

1. Hemichordata (Adelochordata)
2. Urochordata (Tunicata)
3. Cephalochordata (Acrania)
4. Vertebrata (Craniata)

First three sub phyla are grouped together as Protochordata.

Bateson (1885) considered the skeletal structure of the buccal tube *Balanoglossus* to be homologous to the notochord of Tunicata and Acrania (Cephalochordata).

But many scientists do not consider this to be the notochord. They prefer to call it **buccal diverticulum**. Hemichordates show many resemblances with echinoderms than with the chordates (See affinities of Hemichordata). Many scientists concluded that the Hemichordata should be considered as a separate phylum.

But in Hemichordata an endoskeletal element develops from the buccal tube (anterior part of the alimentary canal). This may be a notochord. Except *Rhabdopleura* (a genus of Hemichordata) all protochordates possess perforated pharynx. They increase in number by developing tongue bars. Similar type of multiplication is found in Cephalochordata.

Chordates utilize phosphagens in the muscular activity. It is a compound of the amino acid creatine. Similarly arginine is utilized by non-chordates. Creatine is present in Hemichordates, Tunicates and some echinoderms. But recently some creatine compound has been found in some polychaetes while other polychaetes possessed arginine compounds.

26.3 GENERAL CHARACTERS OF HEMICHORDATA

1. They are marine, worm like animals. They may lead solitary or colonial life. The body is long and slender. Generally they live in 'U' shaped tubes. The body is soft and adapted for burrowing.
2. The body exhibits bilateral symmetry and is not segmented.
3. Three germinal layers namely ectoderm, mesoderm and endoderm are present.
4. The body is divisible into three unequal parts. Proboscis, collar and trunk.
5. Some genera bear tentaculated arms in the collar.
6. Coelom is in the form of five cavities. Proboscis coelom is unpaired. Collar and trunk have paired coelomic cavities. Proboscis coelom and collar coelomic cavities open to the exterior through pores. Trunk coelomic cavities are closed ones.
7. Single layered epidermis is present in the body wall. It possesses mucus secreting glands. These are numerous on the proboscis.
8. Pharynx is perforated, the number of gill slits may vary from one to many pairs. They open to the exterior through gill pores.

9. The circulatory system is of **open type** (capillary system is absent). Definite blood channels, lacunar spaces and heart vesicle are present.
10. Glomerulus or proboscis gland is the excretory organ.
11. Nervous system is in the form of intraepidermal nerve net. It forms mid dorsal and midventral nerve cords. Both are connected by a circular nerve stand.
12. Gonads are numerous arranged in the rows, in the genital wings. Some have only one pair.
13. The sexes are separate in some forms and united in some.
14. Asexual reproduction is by **budding** and also by **regeneration**.
15. Fertilization is external.
16. Development in *Balanoglossus* is through **tornaria larva**. *Saccoglossus* develops directly without a larval stage.
17. Tornaria larva resembles bipinnaria larva of echinoderms.

26.9 CLASSIFICATION

Subphylum Hemichordata (Modern scientists consider this to be the phylum) is divided into two classes. 1) Enteropneusta 2) Pterobranchia.

26.4.1 Class Enteropneusta

It is composed of simple worm like burrowing animals.

These are solitary animals.

Proboscis is the anterior most part of the body.

Collar is simple. It does not possess tentaculated arms.

Numerous 'U' shaped gill slits are present.

Digestive tract is a straight tube. Hepatic sacculations are prominent.

Blood vascular system consists of dorsal sinus, blood vessels and lacunar spaces.

Nerve cord is present in the collar region.

Sexes are separate.

Gonads are many present in the genital wings.

Development is indirect in *Balanoglossus* with a **tornaria larva**. In *Saccoglossus* it is direct.

Asexual reproduction is not known.

Examples: *Balanoglossus* (Fig. 27.1), *Saccoglossus*.

26.4.2 Class Pterobranchia

They are marine and sedentary animals, live in tubes.

They are minute in size and live in colonies.

Shield shaped proboscis is found.

Collar bears tentaculated arms.

Digestive tract is 'U' shaped with mouth and anus situated in the same plane.

Gill slits do not possess 'U' shaped tongue bars.

Nerve cord is not present in the collar region.

Single gonad or a pair of gonads present.

Sexes may be separate or united.

Asexual reproduction is by budding.

Development may be direct or indirect.

The class Pterobranchia is divided into 2 orders. 1) Rhabdopleurida ii) Cephalodiscida.

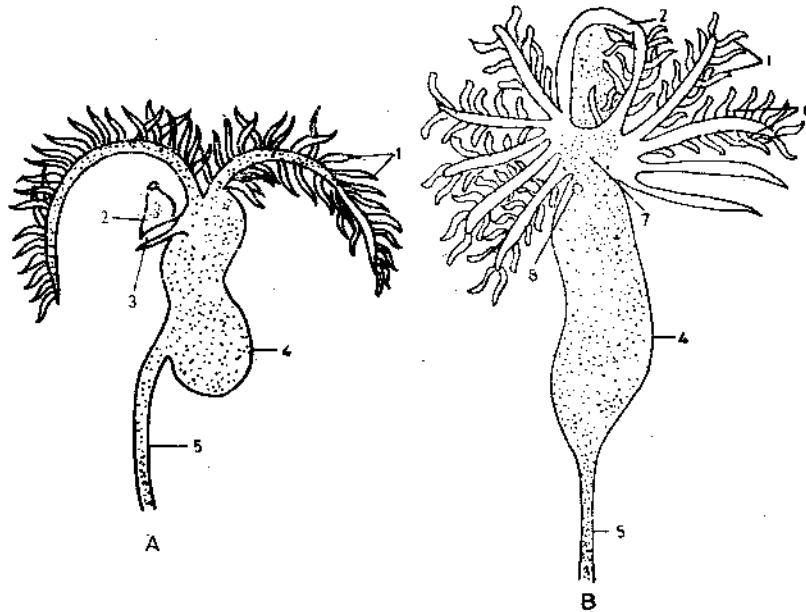

Fig. 26.2 Hemichordates. A. *Rhabdopleura* (an individual). B. *Cephalodiscus* (an individual) 1. Tentacles. 2. Cephalic shield 3. Oral lamella 4. Trunk 5. Stalk 6. Arms of the collar 7. Collar 8. Anus.

i) Order Rhabdopleurida

1. These have two tentaculated arms in the collar region.
2. The gill slits are absent.
3. Only single gonad is present.
4. They form colonies.

A common stolon connect the individuals of a colony

Example: *Rhabdopleura* (Fig. 26.2 A)

ii. Order Cephalodiscida

They may be solitary or may exist in groups (gregarious). There is no connection between various individuals.

All the individuals live in a coenecium.

The collar has many tentaculated arms

Only one pair of gill slits present.

A pair of gonads is found.

Example: *Cephalodiscus* (Fig. 26.2 B)

26.5 AFFINITIES WITH CHORDATA

The Hemichordates have atleast two fundamental chordate characters namely. the structure, functions and development of gill slits are similar to those of chordates particularly *Amphioxus*, which is called a "fish in making".

Dorsal tubular nerve cord is single and nonganglionated as in chordates.

The third fundamental character of a chordate is the presence of notochord or chorda dorsalis. In some lower chordates it may persist through out life. But it is replaced by the vertebral column in the higher chordates. In hemichordates the roof of the buccal cavity has a peculiar skeletal structure. It extends into the proboscis. Earlier it was considered as notochord. Later it was called stomochord as it is present in the buccal tube. But many scientists preferred to call it **buccal diverticulum**. But the buccal diverticulum is mid dorsal in position. It has vacuolated cells and it develops from the gut. In possessing these characters it is resembling the notochord.

Differences with the Chordates

In hemichordates the gill slits are dorsal in position. In chordates they occupy lateral region of the body.

The so called notochord (Buccal diverticulum) is very short. In chordates it occupies almost entire length of the body.

In hemichordates it is ventral to the dorsal blood vessel. In chordates it is dorsal to the dorsal blood vessel.

In hemichordates there is no covering sheath around the notochord (Buccal diverticulum). In chordates the notochord is surrounded by two sheaths. The outer sheath is thin and made up of elastic connective tissue. The inner sheath is thick and made up of fibrous connective tissue.

In hemichordates the 'notochord' develops from the foregut but does not get separated from it. In chordates the notochord develops from the foregut but gets separated.

True notochord possesses large vacuolated cells. Some scientists say that the buccal diverticulum has large vacuolated cells. But the other scientists consider them to be epithelial cells.

In hemichordates the dorsal nerve cord is restricted to collar region. In other parts of the body the intra epidermal nerve net is present. In chordates single, hollow tubular nerve cord occupies the entire length of the body. In the anterior region it is differentiated into brain.

Numerous gonads are present in Hemichordata. In chordates only a pair of gonads are present.

Blood flows anteriorly in the dorsal blood vessel and posteriorly in the ventral vessel as in non-chordates. It is just reverse in the case of chordates.

In hemichordates the heart is dorsally situated. In chordates it is ventrally situated.

Single layered ciliated epidermis is present in hemichordates.

Serological and biochemical tests reveal the hemichordates resemble with the invertebrates in general and with echinoderms in particular.

26.6 AFFINITIES WITH ECHINODERMS

Strong affinity exists between the bipinnaria larva of *Asterias* and tornaria larva of *Balanoglossus*.

The cleavage and gastrula formation is similar in both.

In both the larvae the ciliary band takes a similar course.

In both the coelom develops from the archenteron.

The digestive tract is similar in both i.e. mouth is ventral and anus is posterior.

The anus develops at the blastopore in both.

The origin and arrangement of coelomic cavities are exactly same in both.

In adult condition both have a poorly developed nervous system.

Heart vesicle of hemichordates may be homologous to madreporic vesicle of echinoderm larva.

26.7 AFFINITIES WITH ANNELIDA

1. Both hemichordates and annelids are tube dwellers. Both have burrowing nature.
2. Both ingest mud.
3. Faecal matter is in the form of castings in both.
4. Blood vascular system of Hemichordata resembles with that of Annelida. The heart is dorsally situated in both.
5. Blood flows anteriorly in the dorsal vessel and posteriorly in the ventral vessel in both the groups.
6. Tornaria larva may be modified trochophore larva of annelids.

Differences with Annelida

Nervous system is basically different in both.

Excretory system is in the form of nephridia in annelida. Hemichordates have no definite excretory organs. Glomerulus is considered to excretory in nature.

Pharyngeal perforations are present in Hemichordata and are absent in Annelida.

Roof of the buccal cavity has a skeletal structure called 'notochord' or buccal diverticulum. There is no such structure in Annelida.

After studying the affinities of Hemichordata it may be concluded that Hemichordata can be ranked in between Echinodermata and Chordata as a separate phylum.

Check Your Progress

1. Enumerate the structural features of hemichordates in common with chordates. _____
2. As the stomocord can in no way be treated as equal to notochord, the subphylum Hemichordata is now treated a of invertebrate group.

26.8 SUMMARY

The animals with possess the notochord are called chordates, Eg. sea squirts, fish, frog, snake, bird, rat, cat, dog, bat, whale elephant, man etc. They look so different from each other but at the same time they have common characters.

Chordate origin is under dispute.

There is no general agreement as regards the classification of phylum Chordata.

Presence of notochord in the Hemichordata is doubtful. So there is dispute regarding the systematic position of Hemichordata. Further they show affinities with chordata, Echinodermata and Annelida.

The members of the phylum Chordata are characterised by the three fundamental characters. These are 1) Presence of notochord 2) Presence of gill slits 3) Presence of nerve cord.

26.9 CHECK YOUR PROGRESS — MODEL ANSWERS

1. gill clefts, nerve cord.
2. Phylum

26.10 MODEL EXAMINATION QUESTIONS

I. Answer the following in 30 lines each

1. Give the salient features of a typical chordate.
2. Enumerate the general characters of Hemichordata.
3. Classify Hemichordata with examples.
4. Discuss the affinities of Hemichordata.

II. Answer the following in 10 lines each

1. Notochord 2. Enteropneusta 3. Pterobranchia

UNIT - 27: BALANOGLOSSUS

Contents

- 27.1 Objectives
- 27.2 Introduction
- 27.3 External Characters
- 27.4 Body Wall
- 27.5 Coelom
- 27.6 Skeleton
- 27.7 Digestive System
- 27.8 Respiratory System
- 27.9 Blood Vascular System
- 27.10 Excretory System
- 27.11 Nervous System
 - 27.11.1 Sense organs
- 27.12 Reproductive System
- 27.13 Development
 - 27.13.1 Metamorphosis
- 27.14 Summary
- 27.15 Check your Progress — Model Answers
- 27.16 Model Examinations Questions

27.1 OBJECTIVES

In this unit we shall learn about the detailed study of *Balanoglossus* as a typical example so as to enable the student to understand the organisation of Hemichordata in general. By a detailed study of this unit you are enabled to explain with full confidence that *Balanoglossus* has many dissimilarities when compared to chordates. It is closer to invertebrates in many respects. Systematic position.

Phylum	Chordata
Sub Phylum	Hemichordata
Class	Enteropneusta
Genus	<i>Balanoglossus</i>
Species	<i>B. clavigerus</i>

27.3 EXTERNAL CHARACTERS

The colouration varies in different parts of the body of *Balanoglossus*. Hepatic region is brown, proboscis is yellowish and the collar is orange red., branchial region is yellowish orange.

It emits strong and offensive smell, similar to iodoform.

Slimy substance secreted by the skin emits bright greenish luminiscence.

Shape and Size: The body is delicate and soft. It is worm like elongated and cylindrical in shape. The entire body is ciliated. It is enveloped by mucus secretion. It is bilaterally symmetrical. It measures from 4" to 2'. *Balanoglossus gigas* measures about 7 metres. The body is divided into 3 regions: Proboscis, collar and trunk (Fig. 27.1)

Proboscis or Protosome: This is the anterior most region of the body. It is short, muscular and conical in shape. It continues into proboscis stalk. It is surrounded by the collar. One or two proboscis pores are present near the base of the proboscis on the dorsal surface. Water enters the proboscis coelom through these pores and makes the proboscis turgid. Turgidity makes it an efficient burrowing organ.

Collar or Mesosome: This is also muscular. Circular grooves are present on its surface. Collar forms a funnel-like structure in the anterior portion. This is known as collarette. The mouth is present between the collarette and proboscis stalk on the ventral side.

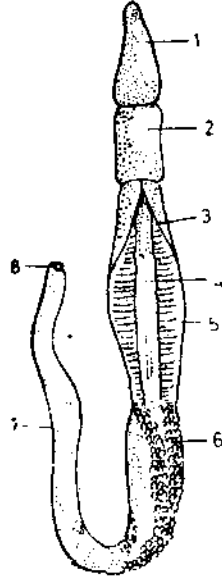

Fig. 27.1 *Balanoglossus* - Dorsal view. 1. Proboscis 2. Collar 3. Branchiogenital region. 4. Gill pores. 5. Genital wing 6. Hepatic region 7. Abdominal or hepatic region 8. Anus.

Trunk or Metasome: Trunk follows the collar. It is the longest part of the body. The trunk is differentiated into 3 regions. Anterior part is **branchiogenital region**, middle part is **hepatic region**. Posterior part is **post hepatic region**.

Many longitudinal rows of **gill pores** are present in the branchiogenital region. They are present on either side of mid dorsal ridge. The branchiogenital region has lateral expansions called genital wings. They fold on to the dorsal side to enclose gill pores. Gonads are present in the genital wings. They open to the exterior through minute pores.

Hepatic sacculations are present in the hepatic or middle region. Post hepatic region is tapering and anus is present at the end on the ventral side.

27.4 BODY WALL

The outer most layer consists of ciliated epithelial cells. In between epidermal cells and gland cells, neuro sensory cells are present. Gland cells secrete mucus which always covers the body. Muscular

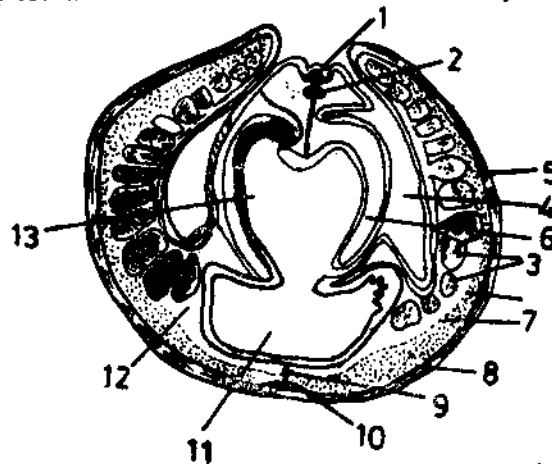

Fig. 27.2 T.S. of *Balanoglossus* (Through branchial region). 1. Dorsal nerve. 2. Dorsal vessel. 3. Gonads. 4. Branchial aperture. 5. Genital wing. 6. Tongue bar. 7. Longitudinal muscles. 8. Epidermis. 9. Ventral vessel. 10. Ventral nerve. 11. Oesophagus. 12. Trunk coelom. 13. Pharynx.

layer is present below the epithelial layer. Circular muscle fibers are present on the outer surface. Longitudinal muscle fibres are responsible for contractions of the body. Nervous layer is intra epidermal. The next layer is basement membrane (Fig. 27.2).

27.5 COELOM

Coelom is by coelomic epithelium or peritoneum. Coelom consists of five separate cavities. Proboscis contains proboscis coelom. It is unpaired cavity. Glomerulus, buccal diverticulum, dorsal sinus project into it. It opens to the exterior by a proboscis pore. Collar has paired coelomic cavities which communicate with each other at certain places. They open to the exterior by a pair of collar pores. The trunk also has paired coelomic cavities which communicate with each other. The proboscis and collar cavities contain sea water. The trunk cavities do not open to outside. They contain coelomic fluid which has coelomocytes (Fig. 27.3)

27.6 SKELETON STRUCTURES

1. Proboscis skeleton 2. buccal diverticulum. 3. branchial skeleton or gill bars and pygochord are the skeletal structures found in *Balanoglossus*.

Proboscis skeleton: It is a plate like structure. It is found in the stalk of the proboscis. It consists of shield shaped plate and two horns or arms. On the midventral side the plate has a keel.

Buccal diverticulum: It is present in the roof of the buccal cavity. It is small, hollow tube like structure. In front it extends into proboscis. Bateson considered this to be the notochord. Some prefer to call it as stomochord. Hyman and other scientists prefer to call it buccal diverticulum.

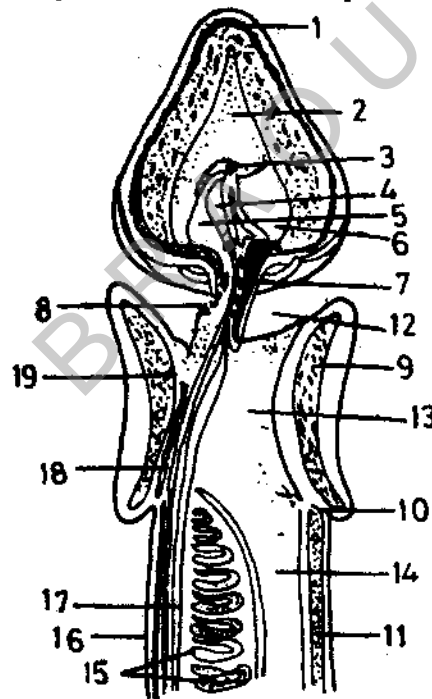

Fig. 27.3 *Balanoglossus* (Median sagittal section). 1. Nerve plexus. 2. Proboscis coelom. 3. Glomerulus. 4. Heart. 5. Pericardium. 6. Stomochord. 7. Proboscis skeleton. 8. Proboscis pore. 9. Collar coelom. 10. Collar trunk septum. 11. Ventral nerve cord. 12. Mouth. 13. Buccal cavity. 14. Oesophagus. 15. Gill slits. 16. Dorsal nerve strand. 17. Dorsal vessel. 18. Nerve Cord. 19. Longitudinal muscles of collar.

Branchial skeleton or Gill rods: Primary and secondary gill bars are supported by gill rods.

Pygochord: It is present in the wall of the post hepatic region on the ventral side. It supports the caudal region.

Musculature: Smooth muscles are present. Proboscis has few circular and well developed

longitudinal muscles. Muscles are well developed in collarette. Collar has poorly developed musculature. Trunk has simple muscles.

27.7 DIGESTIVE SYSTEM

Digestive tract is a straight and wide tube. The mouth is present on the ventral side between proboscis stalk and collarette. It is always kept open. The ciliary action of proboscis brings the food material into the mouth.

Simple ciliated epithelium lines the alimentary canal. Musculature is not developed. The digestive system is divisible into four parts. 1) Buccal tube 2) Pharynx 3) Oesophagus 4) Intestine.

Buccal tube extends upto collar trunk septum. As mentioned earlier roof of the buccal cavity forms buccal diverticulum. Pharynx can be divided into dorsal respiratory region and ventral digestive region. Respiratory region has series of gill slits. Digestive region functions as a food channel. A lateral constriction separates these two parts. A pair of parabranial ridges project into the lumen of pharynx.

Oesophagus lies behind the pharynx. It has spacious lumen. The lateral partition of pharynx continues into the oesophagus to some extent and this part is called post branchial region. Oesophagus leads into the **intestine** It can be differentiated into **hepatic** and **post hepatic** region. Hepatic caeca or hepatic sacculations are present in the dorsal wall of the hepatic region. Post hepatic region or intestine follows the hepatic region. Pygochord, a skeletal structure is present in this region. Post hepatic region leads into the anus which opens to the exterior. Anus is guarded by a sphincter.

Food and Feeding habits: *Balanoglossus* feeds like earthworm. Organic food material enters the mouth along with mud. Feeding is of mucus-ciliary type. Food particles along with sand grains become entangled in mucus strands. Mucus is secreted by the proboscis. Mucus strands enter the mouth. Direct ingestion of food particles is also noted.

Digestion: Entire alimentary canal is ciliated. Lashing movements of cilia cause the food to move forwards. Mucus contains amylase. It digests carbohydrates. Secretions of hepatic caeca or sacculations contain amylase, protease and lipase. These act upon carbohydrates, proteins and fats respectively and complete the digestion. The faecal matter is in the form of castings as in earthworm.

27.8 RESPIRATORY SYSTEM

The respiratory or branchial apparatus consists of two longitudinal rows of gill sacs or gill pouches. These are present in the dorsal region of pharynx. Gill sac consists of elongated 'U' shaped gill slits. The limbs of the gill slits are directed towards the dorsal side. The space between the two limbs of 'U' shaped gill slit is called **tongue bar**. It is part of the coelom. The gill bars and gill septa are

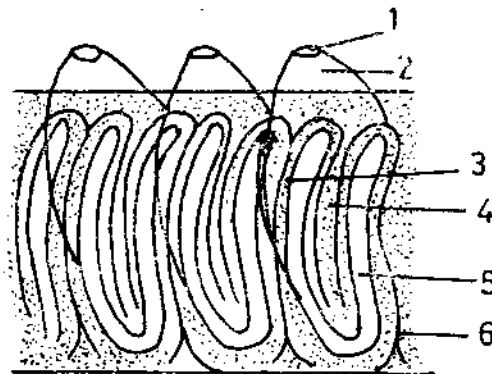

Fig. 27.4 *Balanoglossus* -Part of pharyngeal wall with gill slits 1. Gill pore 2. Gill sac 3. Gill Septum 4. Tongue bar 5. Gill slit 6. Skeletal rod.

supported by skeletal rods. Each gill rod is like a hair pin or 'U' shaped. One arm is in the septum and the other in a tongue bar. Each tongue bar and each septum are supported by two arms which belong to two different skeletal rods. The arms of septa are fused together all along except at posterior end where they appear like a fork. The branchial sac opens to the exterior through a gill pore. It is round or oval. Gill slits, tongue bars and septa have tall ciliated and glandular cells. Cilia lash constantly. They maintain a respiratory current of water. Water enters through mouth and comes out through gill pores. The tongue bars contain capillary net work. Gaseous exchange takes place in branchial apparatus (Fig. 27.4)

27.9 BLOOD VASCULAR SYSTEM

Balanoglossus has well developed and open type of blood vascular system. It consists of small pulsatory dorsal sinus or 'heart', definite blood vessels and lacunar spaces. Dorsal sinus is enclosed in a pericardium. The other names for pericardium are cardiac sac and heart vesicle. The ventral wall of the cardiac sac contains muscle fibres. They contract rhythmically. Many afferent vessels arise from the anterior end of dorsal sinus. They form glomerulus or proboscis gland. Dorsal sinus collects blood from all parts of the body. It sends the entire blood into glomerulus or proboscis gland. From the glomerulus the blood goes to a pair of anterior vessels or afferent vessels and a pair of posterior vessels or efferent vessels.

Afferent vessels are two. One is middorsal proboscis artery and the other is midventral proboscis artery. These are also called afferent glomerular arteries. From the posterior end of the glomerulus an efferent vessel arises on either side. Each one passes to the posterior side. They encircle the buccal tube as peribuccal vessels. Both of them unite to form large **ventral longitudinal vessel**. This ventral vessel gives out a thin collar vessel. It supplies blood to the collar. The ventral vessel gives a ring vessel near the collar trunk septum. Two lacunar net work or plexi arise from the ring vessel. One net work is formed in the body wall and the other in the buccal tube. The ventral vessel in the posterior region runs upto the anus. On its way it supplies blood to various parts of the body namely digestive tract, branchial apparatus and body wall. The blood is supplied in the form of lacunar net work or plexus.

In each gill septum, ventral vessel gives out an **afferent branchial vessel**. It bifurcates and form plexi in the tongue bars. From each tongue bar the blood is collected by **efferent branchial vessel**. These pour blood into dorsal blood vessel (Fig. 27.5)

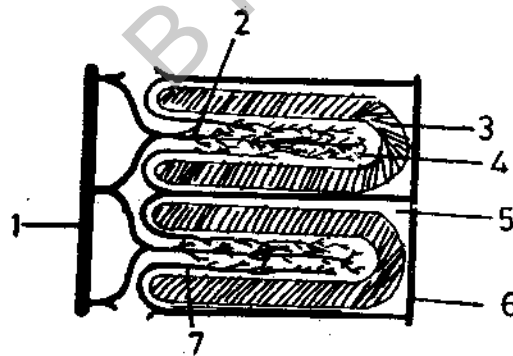

Fig. 27.5 *Balanoglossus*-Blood supply in branchial apparatus. 1. Dorsal blood vessel 2. Efferent branchial vessel 3. Gill slit 4. Tongue bar 5. Gill septum. 6. Ventral blood vessel 7. Afferent branchial vessel.

The dorsal blood vessel arises from anus runs towards the anterior side. On its way it collects blood from digestive tract, hepatic caeca, body wall, branchial apparatus etc. It forms a blood plexus in the intestinal wall. It receives a pair of lateral proboscis veins, one from either side of the proboscis. Dorsal vessel opens into the dorsal sinus.

Dorsal and ventral vessels are lined by endothelium. So they are true blood vessels. The blood flows posteriorly in the ventral vessel and anteriorly in the dorsal vessel. This is **non-chordate character**.

The blood is colourless and may contain white corpuscles.

27.10 EXCRETORY SYSTEM

Proboscis gland or glomerulus is regarded as excretory organ. Excretory material from this gland passes into the proboscis coelom. From here it goes to the exterior through proboscis pore.

27.11 NERVOUS SYSTEM

Primitive type of nervous system is present. It consists of nerve plexus lodged in the epidermis. In the middorsal and midventral lines of the trunk region the plexus is thickened. These are called dorsal and ventral strands. The two strands are connected by another circular strand. This is at the collar trunk border. The dorsal strand extends into the collar. There it enlarges to form **collar cord** or **nerve cord**. It encloses a small cavity. It is considered as a nervous centre. The animal has a dorsal, ectodermal nervous system as in chordates. But it does not extend the entire length of the body.

27.11.1 Sense Organs

There are no definite sense organs. The epidermis of the body wall has some neurosensory cells. On the ventral side of the base of the proboscis a 'U' shaped depression is present. It is called **preoral ciliary organ**. This is considered to be the chemoreceptor.

27.12 REPRODUCTIVE SYSTEM

The sexes are separate. The gonads (testis or ovary, as the case may be) are simple or branched sac like structures. These are present in two dorsolateral rows in branchiogenital region. Each gonad has a narrow ductule. It opens to the exterior by a gonopore. Mature ova and sperms are shed into the sea. Fertilization is external or exogenous.

27.13 DEVELOPMENT

The development is **indirect** with a **tornaria larva**. The cleavage is **holo blastic** and almost **equal**. Cleavage results in a single layered **coelo blastula**. This develops into a double layered **gastrula**. Soon the blastopore closes. The archenteron divides into an anterior **protocoel** and posterior **midgut**.

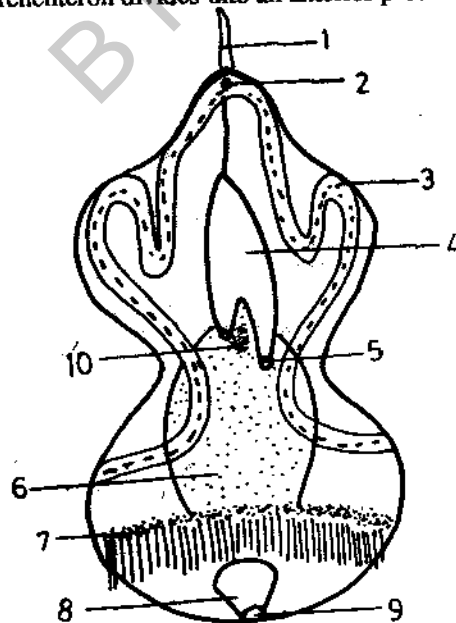

Fig. 27.6 *Balanoglossus*-Tornaria larva (Dorsal view) 1. Ciliary organ. 2. Eye. 3. Ciliary band. 4. Proboscis coelom. 5. Proboscis pore 6. Stomach. 7. Posterior band of cilia. 8. Intestine. 9. Anus. 10. Heart vesicle.

Mouth and anus are formed as invaginations. Anus forms at the place of blastopore. The buccal diverticulum appears. Embryo develops into tornaria larva. It measures upto 5 mm. It is free swimming uniformly ciliated larva. At the anterior end ectodermal thickening called apical plate is present. This plate has apical tuft of longer cilia. Soon the cilia and tuft disappear. Narrow ciliary band appears as in bipinnaria larva of *Asterias* (Echinoderm).

The tornaria larva is an oval, transparent structure with two ciliated bands. The anterior band is called **circum oral band**. It helps in food collection. It has short cilia. The posterior band is called **telotroch**. It serves as locomotory organ. It has longer cilia. A new tuft of short cilia develop on the apical plate. This is called **ciliary organ**. A pair of eye spots develop at the base of ciliary organ. Mouth is formed on the ventral side. Simple tube like alimentary canal is differentiated into oesophagus, stomach, intestine and anus. Coelomic cavities, heart vesicle and other internal organs are formed (Fig. 27.6)

27.13.1 Metamorphosis

During metamorphosis the thin skin of larva becomes thick. The size of the larva decreases. Ciliated bands, sensory tuft of cilia, eye spots and apical plate disappear. The larva constricts so that the proboscis is differentiated from the rest of the body. Soon a second constriction appears differentiating the collar from the trunk. The trunk elongates. Gill bars and gonads develop in the branchiogenital region. The tornaria larva is completely metamorphosed into adult.

Check Your Progress

1. Deuterostome body is divided into three regions termed as and and each region contains a coelomic compartments.
2. Early embryogenesis of Hemichordates is remarkably like that of

27.4 SUMMARY

Balanoglossus is a tube dwelling, worm like animal. Body is divided into proboscis, collar and trunk. The body wall consists of epithelial cells. Gland Cells secrete mucous which helps in cementing the burrow. Coelom consists of five separate cavities. Coelomic fluid has amoeboid coelomocytes. Proboscis skeleton, buccal diverticulum, branchial skeleton or gill bars and pygochord are the skeletal structures present in the body. Musculature consists of circular and longitudinal muscles. Mucous - ciliary type of feeding is present. Digestive organs including the hepatic sacculations described. branchial apparatus consists of 'U' shaped gill slits. Cilia of gill slits maintain a respiratory current of water. Open type of blood vascular system is found. It consists of dorsal sinus or "heart", definite blood vessels and lacunar spaces. Proboscis gland or glomerulus is regarded as excretory organ. Nervous System is in the form of plexus lodged in the epidermis. *Balanoglossus* lacks definite sense organs. sexes are separate. The gonads are simple, present in the branchiogenital region. The development is indirect with a tornaria larva.

27.15 CHECK YOUR PROGRESS — MODEL ANSWERS

1. Protosome, Mesosome, Metasome.
2. echinoderms.

27.16 MODEL EXAMINATION QUESTIONS

I. Answer the following in about 30 lines

1. Write the external characters of *Balanoglossus*.
2. Describe the digestive system of Acron worm *Balanoglossus*.
3. Describe the respiratory system of *Balanoglossus*.
4. Describe the blood vascular system of tongue worm.
5. Discuss the development of *Balanoglossus*.

II. Answer the following in about 10 lines.

1. Habit and Habitat of *Balanglossus*
2. Feeding habits
3. Endoskeleton
4. Tornaria

UNIT-28 SUBPHYLUM - UROCHORDATA - GENERAL CHARACTERS AND CLASSIFICATION

Contents:

- 28.1 Objectives
 - 28.2 Introduction
 - 28.3 General Characters
 - 28.4 Classification
 - 28.4.1 Class - Ascidiacea
 - 28.4.2 Class-Thaliacea
 - 28.4.3 Class-Appendicularia (Larvacca)
 - 28.5 Summary
 - 28.6 Check Your Progress — Model Answers
 - 28.7 Model Examination Question
-

28.1 OBJECTIVES

To discuss the general characters of these peculiar animals which possess notochord in the larval stage only and to show their systematic position in the animal kingdom.

At the end you will be in a position to explain the features of this group of animals which are motile, active with basic chordate characters when larvae, but later become non motile, sedentary and degenerated adults.

28.2 INTRODUCTION

The members of Urochordata (Uros : tail; chorda : notochord;) possess the notochord in the tail region alone, hence the name of the subphylum. These are commonly called sea squirts.

The larval stage exhibits many chordata characters. The chordate characters are lost during metamorphosis. Urochordata is also known as *Tunicata* (Tunica : an undergarment). Entire body is covered by the test or tunic, hence the name *Ascidians* (Ascus : leathery bag).

Aristotle (384-322 B.C.) first described a simple ascidian. Lamarck in 1816 established the groups name *Tunicata* after studying the test. Kowalevsky, a Russian scientist placed them under true chordates after a detailed study of larva. Herdman, Bateson, Garstang, Berrill and Das contributed valuable information regarding urochordates.

28.3 GENERAL CHARACTERS

Urochordates are marine animals of worldwide distribution.

Some are solitary and some are colonial.

The tadpole larva leads a free swimming life. Adult is inactive and leads sedentary life. fixed to a substratum.

Colouration of the body varies. The body may be transparent, translucent or opaque,

Shape and size also vary according to genera.

The entire body is enclosed in a test or tunic. It is made up of tunicine.

The animals has two siphons. One is branchial siphon, present on the anterior side. Second is atrial siphon present on the dorsal side.

Water enters the branchial siphon through the branchial aperture. It comes out through the atrial aperture situated on atrial siphon.

There is a spacious atrial or peribranchial cavity, the viscera is placed in it.

Pharynx occupies the large part of the atrial cavity. It has numerous perforations called stigmata which open into the atrial cavity.

Dorsal lamina or hyperpharyngeal fold is present on the middorsal side of the pharynx. Midventral side of the pharynx is occupied by the endostyle.

Incoming water brings food material and oxygen. Outgoing water carries carbon dioxide, faecal matter, other excretory products and sex cells.

Circulatory system consists of tubular heart. It is located on the ventral side. Numerous blood sinuses and blood vessels are present. Blood contains various types of cells. Flow of blood is reversed periodically. So the same blood vessel acts as an artery for some time and as a vein for some time i.e. it carries pure blood and impure blood alternately.

Asexual reproduction takes place by budding. Sexual reproduction by testis and ovary.

The animals exhibit hermaphroditism i.e. both male and female sexual organs are present in the same individual. Each lobe of the gonad has male and female sex organs.

Regeneration, dimorphism, polymorphism are common in these animals.

Development is indirect with a tadpole larva. It possesses chordate characters which degenerate during metamorphosis. It is called retrogressive metamorphosis.

In some members neoteny or paedogenesis is noted.

28.4 CLASSIFICATION

Subphylum Urochordata (Tunicata) is divided into three main classes:

1) Ascidiacea 2) Thaliacea 3) Appendicularia (Larvacea)

Class-1 Ascidiacea

1. The members of Ascidiacea are all sessile or sedentary.
2. They are all marine and their size is variable.
3. The body is enclosed in a test made of tunicine. It possesses connective tissue fibres, cells and blood vessels.
4. Typically the branchial aperture is on the anterior side and the atrial aperture is on the dorsal side.
5. The Ascidians may be solitary or colonial. In colonial forms each individual zooid may have a separate test or all the zooids may have a common test. This appears as a compound structure.
6. Well developed atrial cavity or peribranchial cavity is present.
7. Innumerable gill pores or stigmata are present on the walls of the pharynx. The walls of the stigmata are heavily ciliated.
8. The notochord is present only in the larval stage.
9. Intestine is looped.
10. Nervous system is reduced to a solid nerve ganglion with few nerves.
11. Heart is enclosed in a tubular pericardium.
12. Asexual reproduction is by budding.
13. Some are colonial and some are solitary.
14. Buds arise from basal stolon. It is the outgrowth of branchial sac.

Class Ascidiacea is divided into 2 orders on the basis of the position of the gonad.

Order-1 Enterogona

1. Gonad is unpaired and is lodged in the loop of the intestine.
2. Neural gland is usually situated on the ventral side of the ganglion.
3. Ocelli and otoliths are larval sense organs.

Examples: *Ascidia* (Fig. 28.1A)

Order-ii Pleurogona

1. Gonads are paired and are lodged in the wall of the atrium.
2. Neural gland is dorsally or laterally located to the ganglion.

3. Larva has an otolith. Ocellus is absent. Larval suckers have adhesive papillae.
Examples: *Herdmania* Fig. 29.1) *Molgula* (Fig. 28.1B), *Botryllus* (Fig. 29.1C)

28.4.2 Class-2 Thaliacea

1. The thaliaceans are widely distributed free swimming tunicates.
2. Some are simple and some form colonies.
3. Caudal appendage is absent in the adult condition.
4. Test is clear transparent and permanent.
5. Body is barrel shaped. It is of medium size.
6. Muscular fibres of the body wall are arranged in complete or incomplete ring like bands.
7. The branchial and atrial apertures are at the opposite ends of the body.

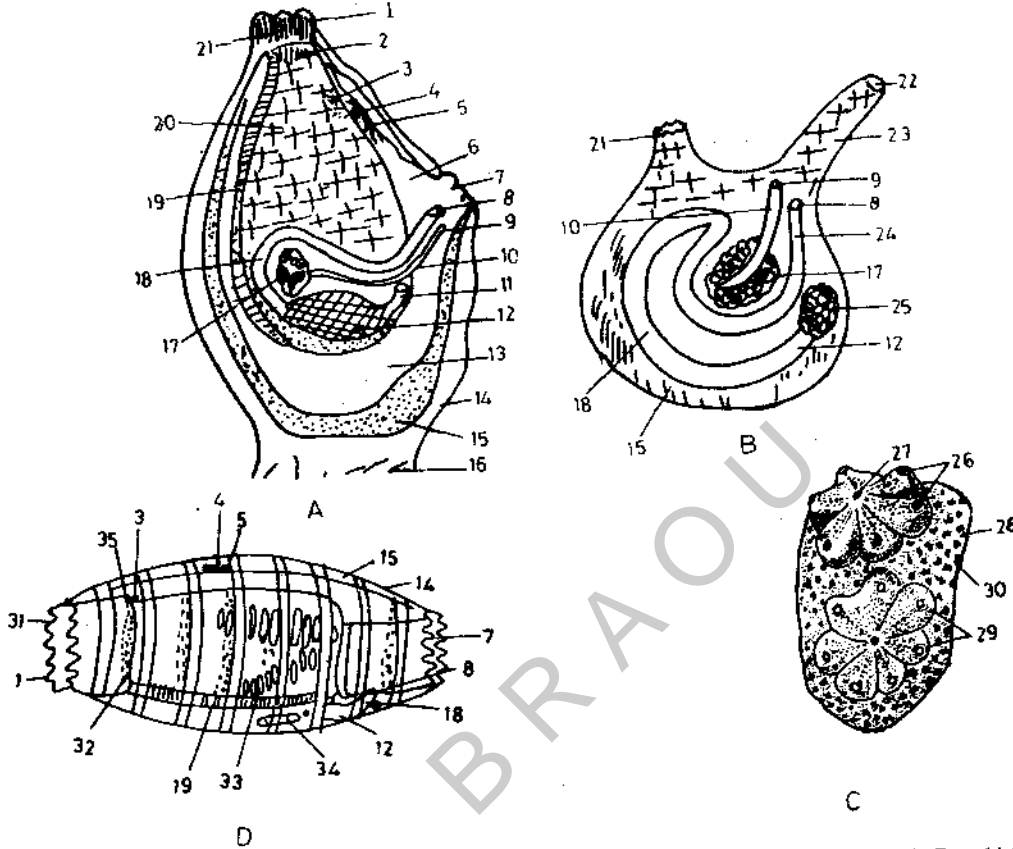

Fig. 28 Some urochordates. A. *Ascidia* B. *Molgula*. C. *Botryllus* colony. D. *Doliolum* (Gonozoid). 1. Branchial aperture. 2. Tentacles. 3. Dorsal tubercle 4. Neural gland 5. Nerve ganglion 6. Cloaca 7. Atrial aperture 8. Anus 9. Genital pore 10. Genital duct 11. Oesophagus 12. Stomach 13. Atrial cavity 14. Test 15. Mantle 16. Base 17. Gonad 18. Intestine 19. Endostyle 20. Pharynx 21. Branchial siphon 22. Atrial siphon 23. Muscle bands 24. Rectum 25. Liver lobe 26. Individual branchial apertures 27. Common atrial aperture. 28. Debris 29. Zooids 30. Common test 31. Branchial lobes 32. Peripharyngeal band 33. Stigmata 34. Heart 35. Prebranchial zone.

In some forms two large stigmata are present. In others many small stigmata are present. These open into the atrial cavity which in turn opens to the exterior.

The adult does not possess the notochord, nerve cord, and tail.

Exhibits hermaphroditism.

Development is direct or indirect.

Most remarkable type of alternation of generations is found.

Some thaliaceans perform locomotion by jet of water coming out from posterior side.

Class Thaliacea is divided into three orders:

Order-i: Doliolida (Cyclomyaria)

They are distributed in warm and temperate seas.

Barrel shaped body is characteristic feature.

Muscle bands are complete hence the name *Cyclomyaria*.

Larva possesses tail.

Gonozooid or solitary sexual phase alternates with oozooid or gregarious asexual phase

Example: *Doliolum* (Fig. 28.1D)

Order-ii Pyrosomida

They lead colonial life, colony looks like a hollow cylinder.

They are phosphorescent

Thick gelatinous test is present around the colony.

Muscle bands are few and occur only towards the ends.

Larval stage is absent.

Fertilization and development takes place inside the body.

Example: *Pyrosoma* (Fig. 28.2)

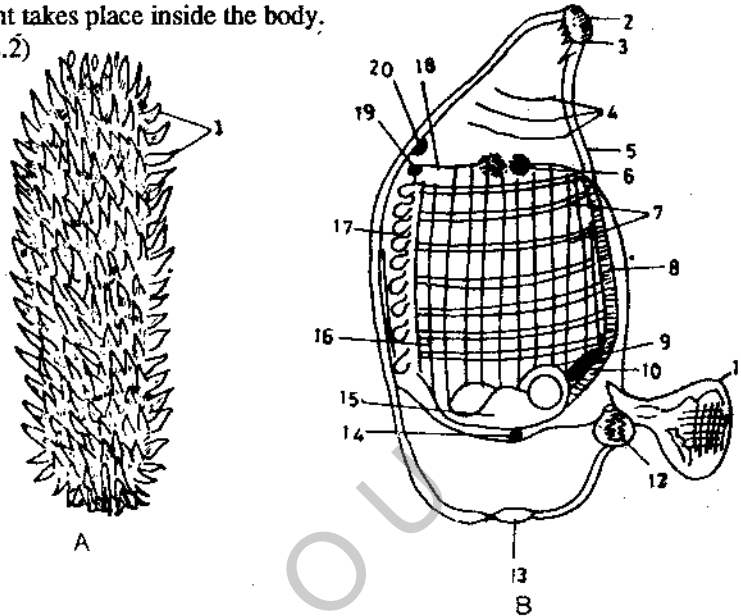

28.2 Colony of *Pyrosoma*. B. Single Ascidio zooid of *Pyrosoma*. 1. Process of the test 2. Branchial aperture. 3. Tentacles 4. Muscular bands 5. Test 6. Luminiscent organ 7. Stigmata 8. Endostyle 9. Intestine 10. Heart 11. Bud 12. Gonad 13. Atrial aperture 14. Anus 15. Stomach 16. Branchial sac 17. Dorsal lamina 18. Peripharyngeal band 19. Dorsal tubercle 20. Nerve ganglion.

Order-iii Salpida (Hemimiyaria)

The body is transparent and prism shaped.

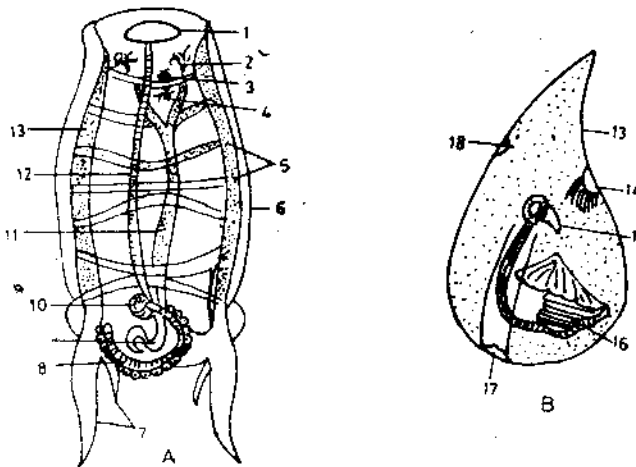

Fig. 28.3A. *Salpa-oozooid*. B. *Oikopleura* in the 'house'. 1. Branchial aperture. 2. Branchial muscles 3. Dorsal tubercle 4. Nerve ganglion 5. Muscle bands 6. Test 7. Test processes 8. Stolon 9. Intestine 10. Heart. 11. Dorsal lamina or gill bar 12. Endostyle 13. Mantle 14. Incurrent pore. 15. Animal 16. Filter apparatus 17. Excurrent pore 18. Back door.

Jet propulsion brings about the locomotion of the body.

The animal exhibits dimorphism, each alternates with the other. a) Solitary oozoid b) Gregarious blastozoid.

Muscle bands are incomplete hence the name *Hemimyaria*.

There is a single pair of very large gill slits.

Development is direct. No larval stage.

Example: *Salpa* (Fig. 28.3 A)

28.4.3 Class Appendicularia (Larvacea)

Larvaceans are transparent, free swimming and marine animals.

The test is in the form of a large envelop called the 'house' which is renewed frequently

House is protective, hydrostatic, respiratory and food filtering structure.

Tail possesses a notochord which is enveloped by a sheath.

There is no atrium.

Nerve cord extends upto the tip of the tail.

Hermaphrodite.

Larva develops the sex organs and reproduces. This is called neoteny or paedogenesis, hence the name Larvacea.

Example: *Oikopleura* (Fig. 28.3B)

Check Your Progress

1. Members of Appendicularia reproduce as larvae, the phenomenon is known as _____.
2. A few polymorphic members of Thaliaceae exhibit _____ of generations in their life cycle.
3. Ascidians are sessile but their tadpole larvae are _____ in water.

28.5 SUMMARY

The body is enclosed in a leathery test or tunic.

Water current enters through branchial siphon and exits through atrial siphon.

Spacious atrial cavity is present in which viscera is lodged.

Tubular heart is present on the ventral side.

Periodical reversal of flow of blood in the blood vessels is a unique character.

Dorsal lamina, and endostyle are present in the pharynx.

Pharynx is very large and is perforated by innumerable gill slits.

Ciliary mode of feeding occurs in *Herdmania*.

As the animal is sedentary, the regular and continuous water current is vital.

Asexual reproduction takes place by budding.

Sexual reproduction is by testis and ovary.

Development is indirect with tadpole larva.

Retrogressive metamorphosis takes place. It is not present anywhere else in the animal kingdom.

28.7 CHECK YOUR PROGRESS — MODEL ANSWERS

1. Paedogenesis.
2. Alternation
3. free Swimming

28.8 MODEL EXAMINATION QUESTIONS

- I. Answer the following in about 30 lines.
 1. Classify Urochordata with examples.
 2. Enumerate the general characters of Urochordata.
- II. Answer the following in about 10 lines.
 1. Ascidiacea
 2. Larvacea

UNIT — 29 HERDMANIA

Contents:

- 29.1 Objectives
- 29.2 Introduction
- 29.3 External Characters
- 29.4 Body Wall
- 29.5 Coelom and Atrium
- 29.6 Digestive System
- 29.7 Respiratory System
- 29.8 Blood Vascular System
- 29.9 Excretory System
- 29.10 Nervous System
 - 29.10.1 Sense organs
- 29.11 Reproductive System
- 29.12 Summary
- 29.13 Check Your Progress · Model Answers
- 29.14 Model Examination Questions

29.1 OBJECTIVES

In this unit a detailed study of *Herdmania* is made so as to enable the student to understand the peculiar organisation of this animal which loses all its chordate characters in its adult life. After completing the study of *Herdmania* you will be in a position to clearly explain the sedentary habit leading to a total loss of chordate characters in the adult and presence of basic chordate characters in the larva.

29.2 INTRODUCTION

Herdmania pallida is a simple ascidian leading solitary and sedentary life called **monoascidian**. It is cosmopolitan in distribution.

Classification

Phylum	Chordata
Sub Phylum	Urochordata (Tunicata)
Class	Ascidiaceae
Order	Pleurogona
Genus	<i>Herdmania</i>
Species	<i>H. pallida</i>

Habit and Habitat

Herdmania lives in the places where polychaetes and gastropods are found. The animal may remain embedded in sand or mud by means of the foot. Foot is a large conical part of oval part of the test. The animal may be a commensal on the shell of gastropods. *Herdmania* protects the gastropod and in turn the gastropod carries the *Herdmania* from place to place.

29.3 EXTERNAL CHARACTERS

Shape, Size and Colour: It is roughly ovoid in shape, the size varies from 6-13 cms in length and less than 5 cms in breadth (Fig. 32.1). It is pinkish in living condition but may turn grey or brown after preservation.

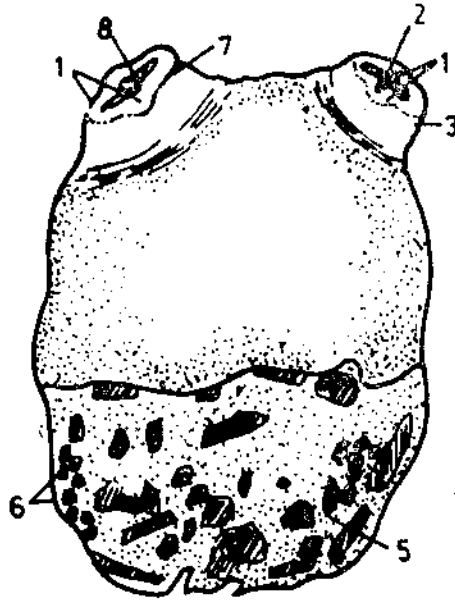

Fig. 29.1 *Herdmania pallida* 1. Lips 2. Atrial aperture 3. Atrial siphon 4. Test 5. Foot 6. Sand grains and other foreign material 7. Branchial siphon 8. Branchial aperture.

Test: The entire body is covered by test or tunic. It is an efficient protective structure. At its upper margin two openings are present. One is anterior branchial aperture and second is dorsal atrial aperture. These are situated on short tubular structures called branchial and atrial siphons. Four lip like structures border each aperture. The branchial aperture is larger and is directed outwards. Atrial aperture is smaller and is directed upwards. The test is soft, leathery and translucent. It is highly vascularized. The ends of the vessels form vascular ampullae near the surface of the test. The outer surface of the test is rough. Small sand particles, shell pieces get attached to the test particularly on the basal foot portion. The test is made up of tunicine.

Cells of the Test:

1. **Amoeboid cells:** Small, nucleated cells with pseudopodia distributed in the matrix (Fig. 27.2)
2. **Eosinophilous cells:** Spherical or oval cells with granular cytoplasm. They stain red with eosin, an acid dye.
3. **Vacuolated cells:** Spherical cells with vacuoles, nucleus is not found.
4. **Granular cells: (Receptor Cells):** These are with highly granular cytoplasm and clear nucleus.
5. **Nerve cells:** Small, branched at the ends usually 2-6 branches are present which anastomose with neighbouring nerve cells, concentrated in the siphons and outer surface of test.
6. **Squamous epithelial cells:** These are flat polygonal cells with red pigment present in vascular ampullae.
7. **Interlacing cells:** The fibrils traverse throughout the matrix of the test and anastomose with each other.

Spicules of the Test: Spicules are calcareous. They are of two types small **microscleres** measuring upto 80 microns long and large **megascleres** measuring upto 3.5 mm in length. Megascleres are again of two types. Spindle shaped megascleres measuring upto 3.5 mm in length. All the spicules have annular rows with minute spines. Megascleres are present in the body wall and visceral parts except heart. The test protects the body. The foot, extension of the test fixes to the substratum. The test helps in respiration.

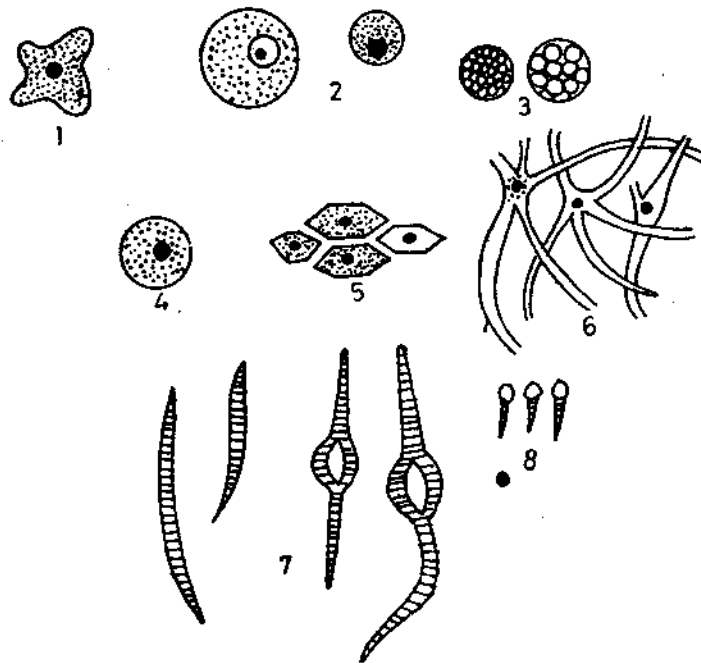

Fig. 29.2 *Herdmania*-cells of the test. 1. Amoeboid cells 2. Eosinophilous cells 3. Vacuolated cells 4. Granular cell 5. Epithelial cells 6. Nerve cells 7. Megascleres 8. Microscleres.

29.4 BODY WALL

Structure: The body wall is also known as **mantle**. It secretes the test. It is thick and muscular in the siphonal region and is thin and transparent in the postero ventral region of the body. Body wall encloses spacious atrial or peribranchial cavity. Along the midventral line mantle is fused with the wall of the pharynx so that the atrial cavity is divided into right and left chambers. These two chambers join together on the dorsal side forming a large cloaca. It opens into the atrial siphon. It measures about 1.5 cms. Branchial siphon measures about 1 cm. Test lines both the siphons internally as it invaginates into them.

Histology: The mantle is made up of 3 layers, outer epidermis, middle mesenchyme and inner epidermis. Outer epidermis consists of a single layer of flat hexagonal ectodermal cells. The

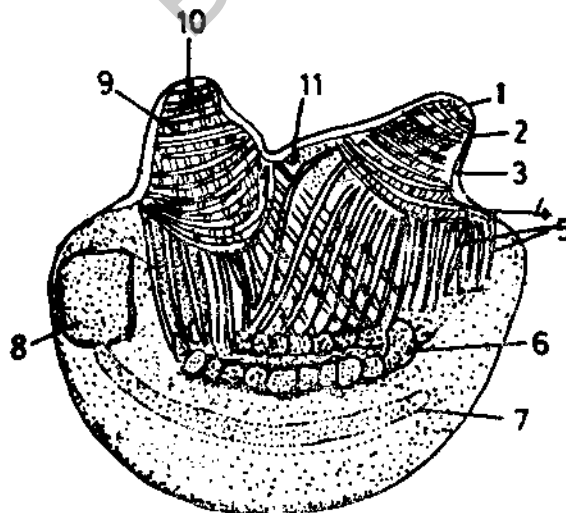

Fig. 29.3 *Herdmania*-Main body (right side). 1. Branchial aperture. 2. Branchial siphon 3. Annular muscle band 4. Mantle 5. Longitudinal muscle bands 6. Right gonad 7. Pericardium 8. Right lobe of liver 9. Atrial siphon 10. Atrial aperture 11. Neural gland.

branchial and atrial siphons represent stomodaeum and proctodaeum respectively. Mesenchyme develops from mesoderm. It consists of a connective tissue containing blood sinuses, cells, nerve fibres, muscle fibres etc. Muscle fibres are long, flat, strip shaped each with a nucleus are found only in the antero dorsal region. They are of two types-longitudinal and annular muscles. The longitudinal muscles extend down as a fan from the atrial and branchial siphons. Annular muscles surround the siphons as rings. Some longitudinal muscles cross with each other in the intersiphonal region. Siphons have strong circular sphincter muscles. Branchioatrial muscle bands connect the two siphons. They are present deep in the mesenchyme. Inner epidermis is formed of a single layer of flat cells. It develops from ectoderm. It forms the lining of atrial cavity.

The body wall or mantle protects the soft viscera. The test is secreted by the epidermis. The test acts as an accessory respiratory organ.

29.5 COELOM AND ATRIUM

Because of the extensive development of atrium the original coelom is largely reduced. It is represented by the pericardial cavity, cavity of the renal organs and reproductive organs.

Atrium is a spacious cavity lined by ectoderm. A part of the atrium surrounds the pharynx but not at the anterior and ventral sides. Here the pharyngeal wall is joined with the mantle. This cavity is called atrial or peribranchial cavity. The stigmata of the pharynx opens into this cavity. Part of the atrium lies on the dorsal side of pharynx and is called cloaca. Gonoducts and rectum open into this part. This in turn opens into atrial siphon which leads to the exterior through atrial aperture. It is bordered by four lips. Around the base of the siphon small atrial tentacles are present but these are vestigial.

29.6 DIGESTIVE SYSTEM

It consists of alimentary canal and digestive glands. Mouth, buccal cavity, pharynx, oesophagus, stomach, intestine, rectum and anus are the parts of the alimentary canal (Fig. 32.4) The buccal cavity is lined with ectoderm and represents the stomodaeum. The branchial aperture represents the mouth. It has four contractile lips. A branchial sphincter is present at the base of the buccal cavity or branchial siphon which can close when needed. Near the sphincter muscle 60 to 64 branchial tentacles are present. There are four groups of tentacles, largest ones (first set) alternate with medium sized ones (second set), in between these two types small tentacles (third set) are present, fourth set or smallest tentacles alternate with all the three types. Each tentacle is a flap like structure bipinnately branched. Lateral branches are called tentaculets which bear secondary branches. These in turn bear tertiary branches. The tentacles form efficient sieve allowing smaller food particles into the midgut. They may serve as chemoreceptors.

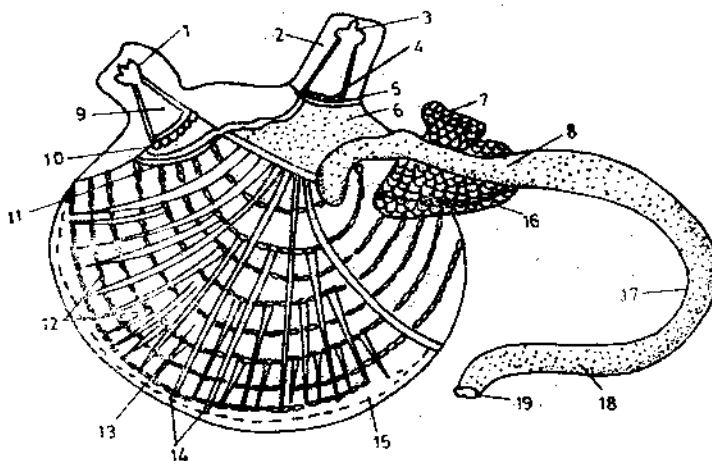

Fig. 29.4 *Herdmania* Alimentary canal. 1. Branchial siphon 2. Atrial siphon 3. Atrial aperture 4. Atrial tentacles 5. Sphincter 6. Cloaca 7. Right lobe of liver 8. Stomach 9. Buccal cavity 10. Branchial tentacles 11. Peripharyngeal bands with grooves 12. Stigmata 13. Branchial sac 14. Transverse vessel 15. Endostyle 16. Intestine 17. Intestine 18. Rectum 19. Anus.

Branchial siphon opens into the **pharynx**. It is the largest part of the alimentary canal. Pharyngeal wall is fused with the mantle along with the midventral line. A pair of peripharyngeal bands divide the pharynx incompletely into two chambers. Anterior chamber is small prepharyngeal zone. Posterior chamber is large **branchial sac** (Fig. 29.5). A ciliated peripharyngeal groove separates the two peripharyngeal bands. The cilia of the bands are longer than those of the groove. The anterior band forms a complete ring. The prebranchial zone is lined by small non ciliated, cuboidal cells.

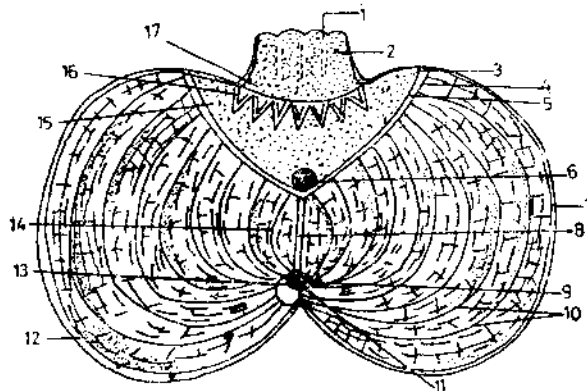

Fig. 29.5 *Herdmania*-Internal structure of pharynx. 1. Branchial aperture 2. Buccal cavity 3. Anterior peripharyngeal band 4. Posterior peripharyngeal band. 5. Peripharyngeal groove 6. Dorsal tubercle 7. Endostyle 8. Dorsal lamina 9. Oesophageal opening 10. Branchial folds 11. Left lip 12. Last branchial fold 13. Right lip 14. First branchial fold 15. Prebranchial zone 16. Tentacles 17. Sphincter.

Branchial sac is very large and extends upto posterior end of the body. It occupies large space in the atrial cavity. The posterior band of the branchial sac has dorsal lamina in the mid dorsal line and endostyle in the midventral line. Dorsal lamina is a fold suspended down from the root of branchial sac. Endostyle is a groove which forms of the sac. The branchial sac is perforated by large number of stigmata through which it communicates with the atrial cavity. Internally 6-10 crescentic longitudinal folds are present in the branchial sac. They run from peripharyngeal band to oesophagus. These folds are short and straight in the surrounding region of the dorsal lamina. On the ventral side they are long and curved. The entire branchial sac bear cilia which maintain water current.

Many blood vessels and sinuses are present in the connective tissue layer. Trabeculae connect the branchial sac with the body wall. These are delicate hollow strands. Each trabeculam carries a blood vessel from the wall of the branchial sac to wall of the body. Trabeculae also keep the branchial sac in position.

The branchial sac is highly vascularised. Its inner surfaces has numerous internal longitudinal vessels. On each side of the branchial wall 80 to 130 internal longitudinal vessels are present. Beneath the outer surfaces of the branchial wall there are 80 to 130 external transverse vessels on each side. Longitudinal and transverse vessels cross each other on each side forming nearly 10,000 small squares called stigmatic areas. Each stigmatic area has 20 stigmata so that there are nearly 2,00,000 of stigmata on each side of the branchial wall. The external transverse vessels give numerous fine branches and run between various stigmata. These are called interstigmatic vessels. Similarly internal longitudinal vessels give numerous fine branches in the stigmatic areas called intrastigmatic vessels.

Dorsal lamina is also known as hyperpharyngeal band. It hangs down from the mid dorsal line of the branchial sac. This is a narrow and thin flap like fold. It lies between the peripharyngeal band and the oesophageal area. There are 20 to 30 short conical languets at its free margin. These are shorter in front and longer behind. All these languets roll up to form a tube through which food-cord passes. It opens into the oesophagus. Dorsal tubercle is present in front of dorsal lamina.

Endostyle or Hypopharyngeal groove: Along, the midventral axis of the branchial sac a prominent groove is present. It extends from the posterior peripharyngeal band to oesophageal area.

Anteriorly it is wider and deeper and posteriorly it is narrower and shallow. In endostyle five glandular tracts alternate with four ciliated tracts. The groove has huge longitudinal tuft of cilia (Fig. 29.6). Beneath the epithelial layer connective tissue is present with blood vessels and nerve fibres. Endostyle secretes mucus and lashing movements of cilia cause forward movement of the mucus, which entangles the food particles. Endostyle is also sensory in function. Similar structure is present in the Cephalochordata and this may form thyroid gland in chordates.

The branchial sac has a small circular oesophageal area behind the dorsal lamina. It has two semilunar lips which enclose opening of the oesophagus. This region has no stigmata and folds. The oesophagus is thick walled and deep brown in colour. After running upto short distance it opens into stomach (Fig. 29.4). Its inner epithelium has a single layer of cylindrical cells. Four ciliated grooves are present in it through which food cords pass.

Stomach is a wide tube with thin walls. It has a sphincter on either side. The fine branches of the pyloric gland, blood sinuses are present in the wall of the stomach.

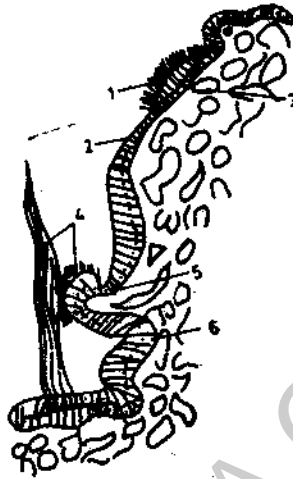

Fig. 29.6 *Herdmania* - T.S. of endostyle 1. Ciliated epithelium 2. Connective tissue 3. Blood sinus 4. Cilia 5. Ciliated epithelium 6. Glandular epithelium.

The stomach opens into the intestine, which is quite long and forms a loop of 'U' i.e. with a proximal limb and a distal limb. The loop is occupied by the left gonad. The intestinal wall has thinner lining, for the sake of absorption. Large blood sinuses and end branches of pyloric gland are present in the intestinal wall.

Intestine leads into the rectum. It is short narrow tube slightly curved and opens into the atrium or cloaca by the anus which has four lips at the outer margin. The digestive system lies on the left side of the branchial sac.

Digestive Glands: The liver and the pyloric gland are the digestive glands in the *Herdmania*. Liver is a large bilobed gland chocolate brown in colour. The larger tube is on the left side and the smaller one is on the right side of the stomach. It opens into the stomach by many ducts. It secretes brownish yellow fluid which is carried to stomach through fine ciliated ducts. The secretion has amylase and protease which are powerful enzymes and lipase is a weak enzyme. Liver is composed of many branching caeca. Each caecum consists of glandular columnar epithelium.

Pyloric gland is a large and highly branched structure. Its ramifications end in the wall of the stomach and intestine. Tubules unite into a single duct and open into the stomach and intestine.

Physiology of Digestion: Ciliary feeding is found in *Herdmania*. Food is filtered hence it is called filter feeder. Food consists of diatoms, algae infusorians. Constant water current is produced by the cilia of the stigmata. Water enters into the branchial siphon through the branchial aperture and goes

goes to the **pharynx**. Through **stigmata** water enters the **atrium** and finally to the exterior through **atrial aperture**. The **branchial tentacles** form a sieve which allows only the microscopic particles to enter the pharynx. The tentacles may act as **gustatoreceptors** (Sense of taste). Powerful reverse current from pharynx flush out the entangled particles. At first the **atrial siphon** is closed, the body muscles contract there by water present in the pharynx rushes to the **branchial siphon** and to the exterior through **branchial aperture**. The glandular tracts of the branchial sac secrete large amount of **mucus**. Lashing movements of cilia bring the mucus towards the dorsal lamina in the form of thin sheets. The food particles of the water current get entangled into the mucus, which reaches the tube formed by the languets of dorsal lamina and goes to the oesophagus in the form of **food cord**. The cilia of the stigmata also prevent the escape of food particles. Oesophagus adds large quantity of mucus to it. Finally it is sent to the stomach where digestion takes place. Amylase digests carbohydrates, protease breaks down proteins and lipase digests the fats. Secretion of the pyloric gland also digests the food. The digested food is absorbed in the intestine. Faecal material passes into the rectum and through the anus into the atrium. Along with outgoing water the faecal strings go out. Intracellular digestion is absent in *Herdmania*. Food is stored as starch grains in stomach, intestine and liver.

29.7 RESPIRATORY SYSTEM

In *Herdmania* **branchial sac** is the main respiratory organ and the **test** is the accessory respiratory organ. Branchial sac possesses numerous **inner epithelial folds** which bathe in the constant water current. Longitudinal, transverse **interstigmatic** and **intrastigmatic** vessels and blood sinuses have thin walls and allow exchange of gases. Blood vessels of **trabeculae** present in the atrial cavity also absorb oxygen.

Vascular ampullae which are present in the external surface of the test also help in respiration. Vascular ampullae have very thin walls with pigment. **Gaseous exchange** takes place between the blood of the ampullae and surrounding water.

29.8 BLOOD VASCULAR SYSTEM

Blood vascular system is peculiar. It consists of **heart** enclosed in a **pericardium**, various blood vessels and sinuses.

Pericardium is transparent, tubular, non contractile structure. It is present in the right ventro dorsal side. It is 7 cm in length and 3 mm in thickness. The pericardium has thick, noncontractile wall composed of connective tissue which contains blood sinuses. It is lined by squamous epithelium. It contains pericardial fluid which is colourless. The fluid has corpuscles of peculiar type.

Heart is enclosed in the **pericardium**. It is connected with the pericardium by thin flap of connective tissue. The heart is as long as pericardium and is open at both ends (Fig. 32.7). Its wall is thin muscular and contractile. The heart does not possess valves. The beating of heart is reversible periodically in dorsoventral and ventrodorsal directions. Therefore blood flows in the reverse direction alternately. This peculiar flow of blood is made possible because there is a pear shaped body in the middle of the pericardial cavity which it moves to and fro like a shuttle. During relaxation or diastole of the heart, this structure remains in its normal position (middle of the cavity). During systole it moves in opposite direction of the wave of contraction of the heart and presses against the opposite end. The blood flows in the needed direction and blood flow in opposite direction is prevented.

Blood Vessels: The animal has well developed blood vessels. The larger vessels have lining of endothelium. The capillary system is absent but sinuses and lacunae are present.

The ventral aorta, dorsal, aorta, branchio visceral vessel and cardio visceral vessel are the four main vessels.

Ventral aorta is the longest vessel. It starts from the ventral end of the heart and divides into two **anterior** and **posterior** vessels. These are located in the branchial sac just beneath the endostyle.

Anterior vessel gives many transverse vessels to the wall of branchial sac. Peripharyngeal vessel and a subtentacular vessel join the anterior vessel. Peripharyngeal vessel which is outside the peripharyngeal groove of the pharynx sends numerous branches to the mantle. The subtentacular vessel sends tentacular vessels into the branchial tentacles and few siphonal vesesls into the branchial siphon. The posterior vessel runs to the oesophageal area and supplies transverse vessels to the branchial wall like the anterior vessel. The ventral aorta gives a stout ventral test vessel which supplies blood to the test.

Dorsal aorta is found in the mid dorsal wall of the branchial sac just below the dorsal lamina. Anteriorly it supplies blood to the neural complex and then joins the peripharyngeal and subtentacular vessels. Posteriorly it continues into branchio visceral vessel. Branchial wall sends paired transverse vessels to the dorsal aorta.

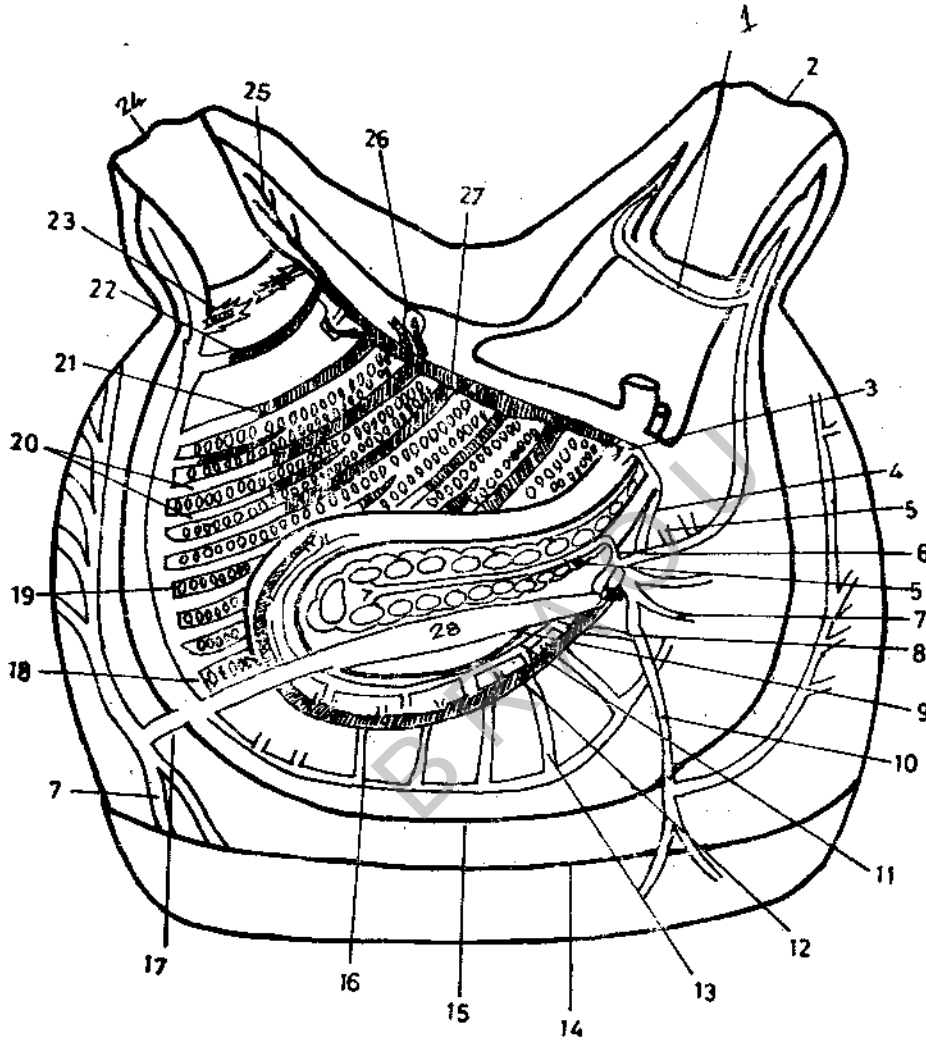

Fig. 29.7 *Herdmania*-Blood vascular system 1. Subtentacular vessel 2. Atrial aperture 3. Branchiovisceral vessel 4. Right oesophageal vessel 5. Gonadial vessel 6. Cardio-visceral vessel 7. Test vessel 8. Gastric vessel 9. Left hepatic vessel 10. Dorsal test vessel 11. Dorso intestinal vessel 12. Ventrointestinal vessel 13. Transverse vessel 14. Test 15. Mantle 16. Ventral aorta 17. Ventral test vessel 18. Anterior branch of ventral aorta 19. Stigmata 20. Transverse branchial vessel 21. Peripharyngeal vessel 22. Subtentacular vessel 23. Tentacular vessel 24. Branchial aperture 25. Siphonal vessel 26. Neural vessel 27. Dorsal aorta 28. Heart.

Branchiovisceral vessel arises from the posterior end of the dorsal aorta. After running upto a little distance it divides into a stout left ventro intestinal vessel and a small right oesophageal vessel. The ventro intestinal supplies to the left up of the oesophageal area, left lobe of the liver and the stomach and continues into the ventral wall of the intestine in the form of fine vessels. Right oesophageal supplies blood to right lobe of the liver and oesophagus.

The dorsal end of the heart gives off **cardiovisceral vessel** and it travels towards the dorsal side dividing into numerous branches. The right **hepatic vessel** supplies blood to the right lobe to the liver, **oesophageal vessel** supplies to the oesophagus. The **test vessel** travels through the mantle and supplies blood to the test. The cardiovisceral vessel then curves to the left side of the body and divides into three vessels. The first is the **median dorsal**, second one is the **left gonadial** and the third is **gastro intestinal test vessel**. The median dorsal runs to the atrial siphon along the mid dorsal line of the body, from where three branches arise, one to the left lip of the oesophageal area second to the left lip of the oesophageal area and third to the gonad. Finally the median dorsal branch gives out 6-8 siphonal vessels to the atrial siphon. It joins with the subtentacular vessel which is in a circular form.

Left gonadial branch supplies blood to the left gonad. The **gastrointestinal** is the longest vessel and divides into two branches. The first or **dorsointestinal vessel** runs along the dorsal wall of the intestine and supplies blood to the stomach, intestine and left lobe of the liver. The second or **gastro test vessel** divides into gastric vessel which supplies blood to the stomach and test vessel which supplies blood to the test.

Course of Circulation: When heart contracts from the dorsal to the ventral end the deoxygenated blood is collected into the cardiovisceral vessel and is poured into the heart. From the heart the blood goes into the ventral aorta, from there into the branchial sac through branchial vessels and to the test vessels. Gaseous exchange takes place in the branchial sac. Dorsal aorta collects the oxygenated blood and drives the blood into branchiovisceral vessel which distributes the blood into various parts of the viscera. Deoxygenated blood is collected by the cardio visceral which sends the blood into the heart.

When the heart contracts from the ventral to the dorsal end, ventral aorta drives its oxygenated blood into the heart. This blood is pumped into the cardiovisceral vessel which distributes it to the various parts of body. Branchiovisceral vessel collects the impure blood and sends it to dorsal aorta. It carries the blood to branchial vessels of the branchial sac where aeration takes place. The oxygenated blood reaches the ventral aorta. The ventral test vessel also sends its pure blood to ventral aorta, thus the heart behaves as a **systemic pump** and **respiratory pump** (branchial pump) alternately. The beat in one direction continues for 2 or 3 minutes, stops for a while and then starts beating in the reverse direction. The process is repeated continuously (Fig. 29.8).

The course of circulation is unique to Tunicata. Each blood vessel acts as an artery as well as a vein alternately for a little time.

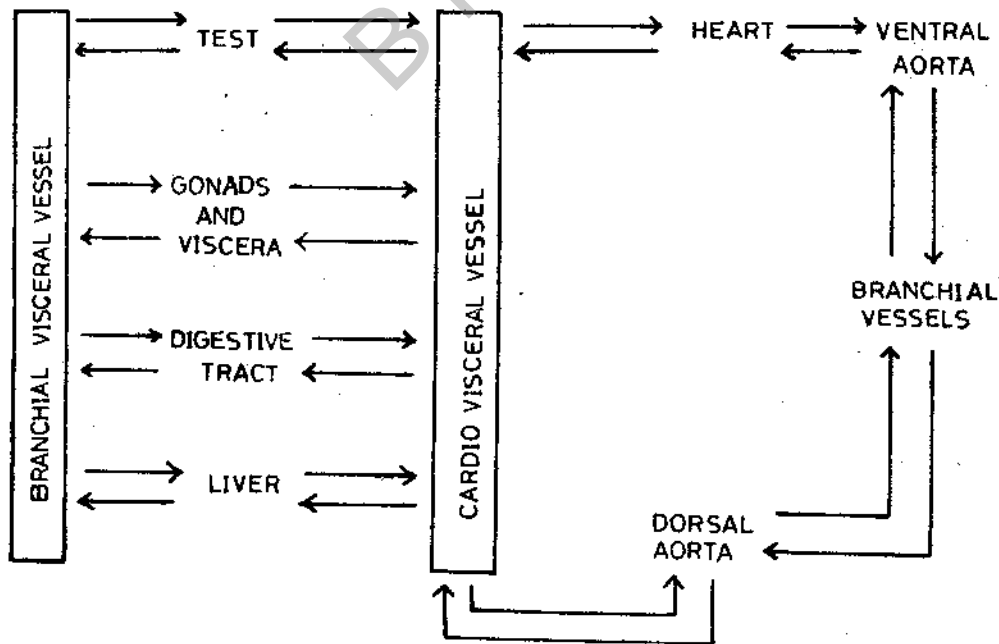

Fig. 29.8 *Herdmania*-Course of blood circulation.

Blood: Blood of *Herdmania* is reddish transparent fluid. 8 types of corpuscles are known:

1. **Orange corpuscles:** These are large spherical non nucleated corpuscles. Cytoplasm is granulated with orange pigmentation.
2. **Signet cell or Single vacuolated cells:** Large, spherical, colourless non nucleated cells. Each cell has a single vacuole.
3. **Yellow green cells:** Large, spherical non nucleated with a yellowish green pigment. 4 or 5 vacuoles are present in each cell.
4. **Vacuolated or Compartment cells:** Large spherical, non nucleated corpuscles. Yellow pigment is present in them. Many small vacuoles are found in each cell.
5. **Eosinophilous cells:** Each cell contains large eccentric nucleus and brown pigment is present in granular cytoplasm. Small in size.
6. **Lymphocytes:** Very small, amoeboid cells each with a large central nucleus. Light brown pigment is found.
7. **Leucocytes (Macrophages):** Medium sized, colourless amoeboid cells each with a large central nucleus.
8. **Nephrocytes:** Vacuolated large granules which are excretory in function.

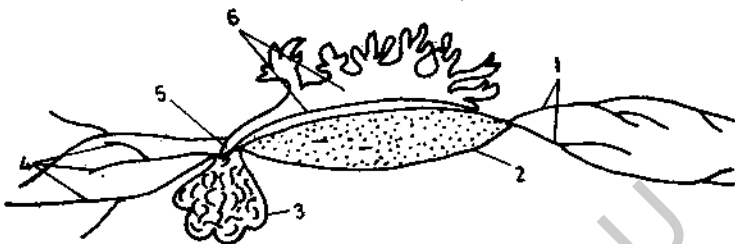

Fig. 29.9 *Herdmania* - Neural complex. 1. Posterior nerves 2. Nerve ganglion 3. Dorsal tubercle 4. Anterior nerves 5. Neural duct 6. Neural gland.

29.9 EXCRETORY SYSTEM

Neural gland is the chief excretory organ in *Herdmania*. It is present in the mantle in the intersiphonal region above the nerve ganglion and behind the dorsal tubercle. It is a small oval or elipsoidal structure. It is brownish in colour and measures 4 mm in thickness. The neural gland has few central tubes which project out from the peripheral region of the gland. The central tubes open into a long non-ciliated central canal. The canal leads into a narrow duct in the anterior region. It has ciliated cells (Fig. 29.9). It bends downwards and passes between the anterior nerves. It opens into the prepharyngeal zone of the pharynx through a pore. It has numerous cilia and opens near the base of the dorsal tubercle. The central tubes, central canal and duct of neural gland have single layered wall which has small round and non-ciliated cells. Dark granules are present in the remaining gland. Blood sinuses and corpuscles are present in it. The excretory material from the neural gland and in turn it sends into the pharynx. Outgoing water of the pharynx carries the waste material to the out side. The excretory material is in the form of **xanthine** and **urate particles**. These get deposited in some cells called nephrocytes. They pass the neural gland from where they are eliminated. The neural gland, nerve ganglion and dorsal tubercle are together called **neural complex** and is considered to be similar to the pituitary body of vertebrates.

29.10 NERVOUS SYSTEM

The nervous system is well developed in the larval stage. The larva consists of an elongated tubular nerve cord as in a typical vertebrate but during retrogressive metamorphosis the adult losses almost all the chordate characters. The nervous system degenerates to a solid, elongated pinkish nerve

ganglion (Fig. 29.9). It is embedded in the mantle in the intersiphonal region ventral to the neural gland.

It consists of an outer cortical region which has large ganglionic cells and inner medullary region has matrix. The nerve cells are of bipolar and multipolar type. The ganglion produces reflexes.

The nerve ganglion consists of three anterior and two posterior nerves. All the nerves are of mixed type. Out of the three anterior nerves two are stout and one is quite thin. It innervates the mouth and neighbouring region. The first two surround the branchial siphon. The anterior nerves after innervating the tentacles, muscles and the inner epithelium enter into the test wall. Similarly the posterior nerves surround the base of the atrial siphon. They innervate the tentacles, digestive tract and the other visceral parts. Finally in the test the nerve fibres form nerve net work which is more prominent around the receptor cells.

29.10.1 Sense Organs

The following sense organs are found in *Herdmania*:

Tangoreceptors (Sensitive to Touch): These are granular nucleated cells which are scattered in the vascular and nonvascular parts of the test, and the muscles of siphons.

Photoreceptors (Sensitive to light): Margins of the siphons have bright red coloured spots with pigmented, granules in the cytoplasm.

Chemoreceptors (Sensitive to chemical nature of the water): Tentacles and dorsal tubercle are chemoreceptors.

Rheoreceptors (Sensitive to changes in the gravitational force): These are present in the branchial and atrial siphons.

Thermoreceptors (Sensitive to changes in temperature): The cells lining the siphons are sensitive to detect the change in the temperature.

Olfactoreceptors (Sensitive to smell): The cells lining the branchial tentacles are considered to be olfactoreceptors. They test the quality of incurrent water.

Dorsal Tubercle: It is present in the prebranchial zone, anterior to the dorsal lamina. It consists of a broad base and a pair of spirally coiled structures which emerge from a common base. Each spirally coiled lobe has a ciliated channel which is spirally coiled. In the lobes they are continuous with each other. The funnel shaped neural pore opens near the basal portion of the dorsal tubercle. The inner side of it has loose connective tissue which has nerve fibres and blood sinuses. It may serve as gustatoreceptor, chemoreceptor and olfactoreceptor.

29.11 REPRODUCTIVE SYSTEM

Herdmania is a **hermaphrodite** and **oviparous**. Self fertilization is not possible because they are **protogynous** animals in which the ovaries mature first. Hence cross fertilization takes place. the animal has two large gonads projecting into the atrial cavity from the mantle. The left gonad

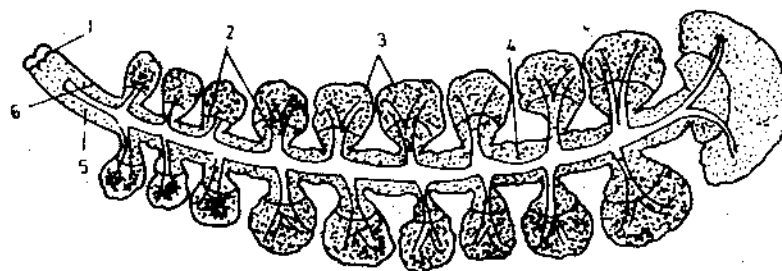

Fig. 29.10 *Herdmania* - Left gonad. 1. Oviducal aperture 2. Ovaries 3. Testes 4. Vas deferens 5. Oviduct 6. Spermiducal aperture.

occupies the region between the pericardium and mantle. Each gonad is elongated and lobulated (Fig. 29.10). It is wider at the ventral end but becomes narrow at the dorsal end. Each gonad consists of 10-25 lobes and are arranged on either side of the central axis. The single ventral most lobe is the largest and is in crescent shape. The others are paired ones. They are oval in shape and gradually become smaller towards the atrial end of a gonad. Each lobe of a gonad has both male and female reproductive organs. Peripheral region of the lobe is the **testicular part** which is red in colour with papillated surface. Inner region is the ovarian part which is pink in colour. The testicular region has numerous spermatocae which wall has spermatogonia in the outer layer and spermatocytes in the inner layers. Spermatocyte develops into a sperm. They become free and are set free in the lumen of the caecum.

The sperm is minute, measuring 4 μ long. The head of sperm is produced into a prominent process in the anterior region. The neck or middle piece continues into the tail which is notably long. Three types of sperms are known. In the first type beak and neck are almost of same length. Second variety has longer beak and the third type has longer neck. The released sperms pass into a few spermatoc tubules which unite to form a single ductule. The ductules of all the lobes join to form a narrow vas deferens. It runs along the central axis of the gonad and opens on a papilla which is small thick walled and is on the dorsal end. The inner side of the vas deferens is ciliated.

The ovarian zone develops ova. The follicular wall of ovaries give rise to ova and they are dropped into the cavity of the follicles. The other follicular cells nourish and protect the developing ova. A mature ovum has yellowish yolk and nucleus which is eccentric in position. The nucleolus present in the nucleus is also eccentric. Thin vitelline membrane surrounds the ovum secreted by ovum itself. This is the primary membrane. It is surrounded by two secondary membranes inner and outer chorions secreted by the follicle cells (Fig. 29.11). Perivitelline fluid is present in the space between the vitelline membrane and inner chorion. Inner follicle cells are present in the fluid, some are freely suspended in the fluid and some are attached to the inner chorion. These cells nourish the developing ovum.

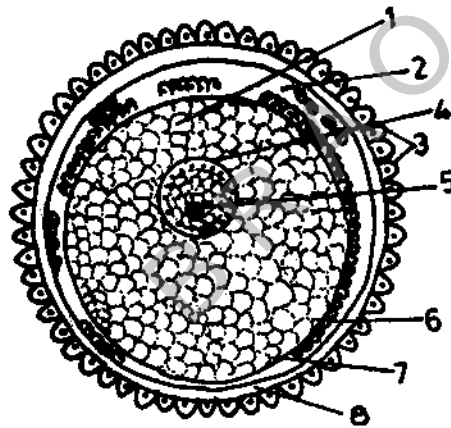

Fig. 29.11 *Herdmania*-A mature ovum 1. Yolk 2. Perivitelline fluid 3. Outer follicle cells 4. Nucleolus 5. Inner chorion 7. Vitelline membrane 8. Outer chorion.

Outer follicle cells are vacuolated and are attached to the surface of the outer chorion and help the ovum to float. The ovum lies eccentrically in the perivitelline fluid. This is unique character of the animal.

Fertilization: *Herdmania* is protogynous i.e., the ovaries mature first and the testes mature later. Mature ova and sperms are liberated into the cloaca and from there they emerge out through the outgoing water. Fertilization is external which takes place in the sea.

Check Your Progress:

1. *Herdmania* separates plankton from the current of water to obtain its food. This method is called as.....

2. Periodical reversal of blood flow direction in *Herdmania* seems to be due to the presence of a pea shaped body in the
3. The chief excretory organ of *Herdmania* iswhich is considered as homologous to gland.

29.12 SUMMARY

Simple ascidian leading solitary and sedentary life.

Herdmania is ovoid in shape. It is enclosed in a test made up of tunicine. Test has various types of cells.

It is a ciliary feeder which takes micro organisms, diatoms etc.

As this is marine, aquatic respiration takes place.

When the animal is alarmed two jets of water come out through its branchial and atrial aperture.

Atrium is a spacious cavity lined by ectoderm.

Due to the extensive growth of atrium, coelom is obliterated.

Midventral line of the branchial sac has a prominent groove called endostyle.

Middorsal line of branchial sac has a thin flap like fold known as dorsal lamina.

Heart is a tubular structure present in the ventro dorsal region.

Neural gland is the chief excretory organ.

Nervous system is well developed in the larval stage.

It is a hermaphrodite. Fertilization is external.

Chordate characters of larva degenerate during metamorphosis. This is called retrogressive metamorphosis.

29.13 CHECK YOUR PROGRESS — MODEL ANSWERS

1. ciliary feeding
2. pericardium
3. neural gland, pituitary

29.14 MODEL EXAMINATION QUESTIONS

I. Answer the following in about 30 lines each.

1. Write the external characters of *Herdmania*.
2. Discuss the digestive system and physiology of digestion of sea squirt (*Herdmania*).
3. Describe the respiratory system of *Herdmania*.
4. Describe the blood vascular system of sea squirt.
5. Give the details of reproductive system of *Herdmaian*.

II. Answer the following in about 10 lines each

1. Feeding habits 2. Shuttle circulation 3. Tunic 4. Pharynx.

UNIT-30 DEVELOPMENT OF HERDMANIA AND AFFINITIES OF UROCHORDATES

Contents

- 30.1 Objectives
- 30.2 Introduction
- 30.3 Development
 - 30.3.1 Cleavage
 - 30.3.2 Gastrulation
 - 30.3.3 Development of larval organs
 - 30.3.4 Tadpole larva
- 30.4 Metamorphosis
- 30.5 Affinities
- 30.6 Summary
- 30.7 Check Your Progress — Model Questions Answers
- 30.8 Model Examination Questions

30.1 OBJECTIVES

This unit deals with the process of development of *Herdmania*, with emphasis on the retrogressive metamorphosis, a unique feature of urochordates. It also discusses the affinities of urochordates. At the end you will be able to explain that the metamorphosis in *Herdmania* leads to retrograde the well defined chordate characters appeared in free swimming tadpole. This aspect coupled with a sedantary life forms an important step in the chordate origin.

30.2 INTRODUCTION

Eggs of *Herdmania* are homolecithal, smaller and less yolky. On being externally fertilized in sea water, the egg undergoes successive cleavages leading ultimately to a free swimming tadpole larva which metamorphosis in a peculiar fashion characteristic of ascidians, which is known as retrogressive metamorphosis.

30.3 DEVELOPMENT

As soon as a sperm enters an ovum near the vegetable pole, the cytoplasm of the ovum is differentiated into three areas. 1) clear cytoplasmic region which is future ectoderm 2) Grey yolky region at the vegetal pole which is the future endoderm. 3) Yellow lipid crescent round the egg near the central line which is future ectoderm.

Opposite to yellow crescent another crescent appears. This is the future chorda-neural tube from which notochord and nerve cord develop.

30.3.1 Cleavage

About half an hour after fertilization cleavage starts. Segmentation is complete and holoblastic. It results in a coeloblastula which is spherical in shape. It encloses in a blastocoel. First cleavage is vertical. Second cleavage is also vertical but it is at right angles to the first one. Cleavage is of determinate type. Posterior cells are a little smaller and anterior cells are larger. Third cleavage is horizontal but passes a little above the equatorial line. It produces eight blastomeres, four of them (upper) are smaller and are called micromeres and the lower four are larger called megameres or macromeres. After 3 successive cleavages a coeloblastula is formed which is flat. It has a fluid filled cavity called blastocoel surrounded by micromeres and megameres which arrange themselves as a thick wall (Fig. 30.1 A.B.C.).

30.3.2 Gastrulation

After the sixth division gastrula is formed by invagination of macromeres. It is called emboly. At this stage the presumptive endoderm gradually sinks into the blastocoel which gets reduced. The endoderm almost meets the ectoderm on opposite side. This results in two layered gastrula. As the macromeres invaginate, they enclose a spacious cavity known as archenteron. It is wide in the early stages but later becomes narrow. Meanwhile the blastocoel obliterates. The embryo elongates, the blastopore closes. This is the posterior end of the embryo. Micromeres develop towards dorsal side, as a result a curved tail appears (Fig. 30.1 D.G.)

30.3.3 Development of Larval Organs

Nerve Cord: 1) The ectodermal cells of mid dorsal line differentiate to form a narrow **medullary plate**. It develops folds on the lateral sides. 2) The medullary plate sinks downwards to form a medullary groove. 3) The lateral folds come closer and meet together. Thus the **neural tube** or **dorsal nerve cord** is formed. It gets separated from the remaining ectoderm. Soon after formation the neural tube opens on either side but its posterior end is closed first. After some time the anterior opening or **neuropore** also closes. **Cerebral vesicle** is formed on the right half of the neural tube. Two pigment spots or **ocelli** and an **otolith** (organ of equilibrium) develop in the cerebral vesicle.

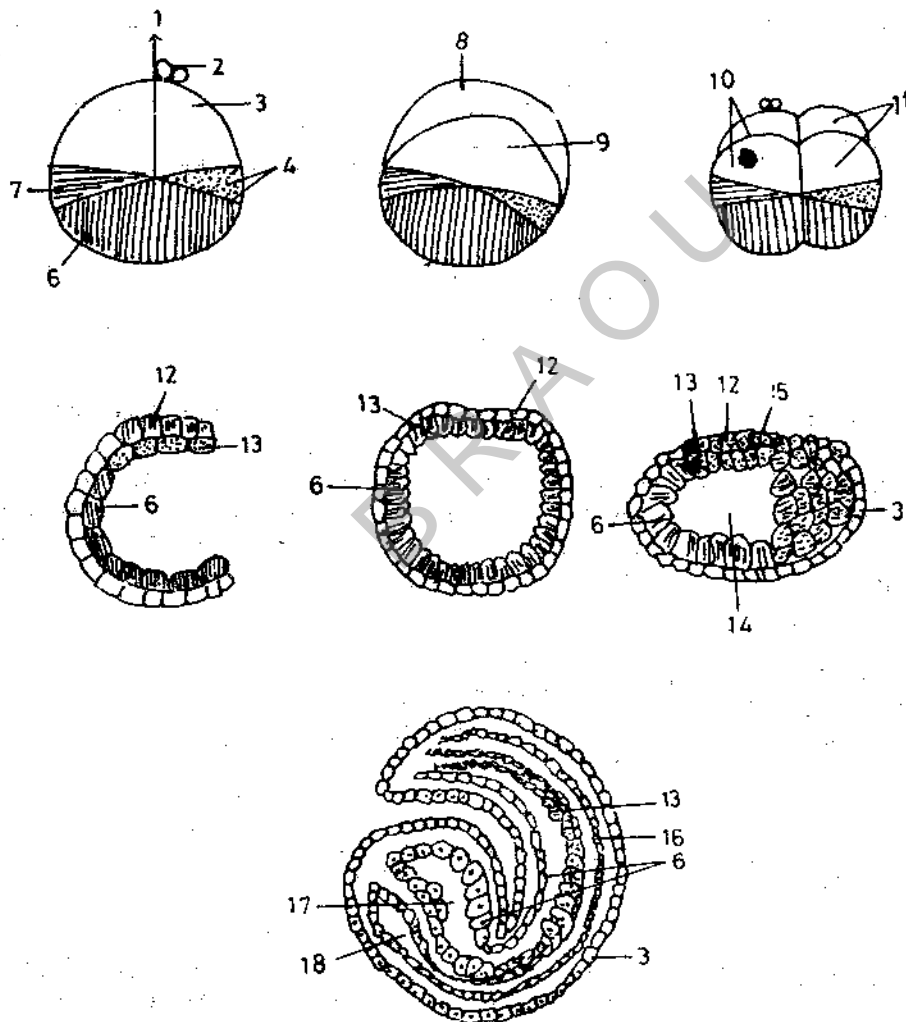

Fig. 30.1 *Herdmania*-Stages of development. A. Zygote. B. 2 celled stage. C. 4 celled stage. D. Gastrula in section E. C.S. of gastrula. F. Developing embryo. G. Early stage of larva. 1. Animal pole 2. Polar bodies 3. Ectoderm 4. Chordaneural tube 5. Vegetal pole 6. Endoderm 7. Mesoderm 8. Left blastomere 9. Right blastomere 10. Posterior blastomeres 11. Anterior blastomeres. 12. Neural plate 13. Notochord 14. Archenteron 15. Blastopore 16. Nerve cord. 17. Mesenteron 18. Neural vesicle.

This is also known as sensory vesicle or neural vesicle. Ocelli are dorsally located and otolith is ventrally situated in the vesicle. The left half forms future neural duct of the adult. Soon after formation both ends of the ducts close. But later anterior end opens into the stomodaeum of larva. In adult it develops as the prebranchial zone of the pharynx.

Notochord: Beneath the medullary groove the endoderm cells develop a long and narrow band, and form the notochord. The gut is formed from the archenteron. The neural tube extends into the tail. It is dorsally located to the notochord. This is the future nerve cord. Just behind the cerebral vesicle ectoderm of the mid dorsal region invaginates to form the atrium. Part of the atrium covers and pharynx which is still in formation. Different parts of the alimentary canal develop from the archenteron. Mouth appears as an ectodermal invagination on the dorsal side. It joins with the endodermal evaginations so that continuous alimentary canal is formed. Pharynx modifies into branchial sac. Endostyle develops in the ventral wall and gill slits in the lateral walls of branchial sac. The gill slits increase in number. They connect the branchial sac with that of atrial cavity. Ventral wall of the pharynx gives out two small outgrowths which develop into heart and pericardium. Inner wall of the outgrowth develops into heart and outer wall constricts off from pharynx and develops into the pericardium. Three protuberances develop in the anterior region of the larva, these are adhesive papillae. Test develops on the entire body surface and also on the mouth, so that mouth is functionless. Coelom is mesodermal in origin. It is formed by splitting of the mesodermal plates. When atrial chamber develops the coelom obliterates. Till now the yolk nourishes the developing embryo. Later inner follicle cells nourish. They become detached from the inner chorion.

The larva is fully formed in about 8 hrs or so after fertilization. By constant movement of the tail the chorions get ruptured. The tail of the larva becomes straight. Hatching takes place and the tadpole larva is set free in the water. It leads a free swimming life for a short time.

30.3.4 Tadpole Larva

The larva measures 1.2 mm. It is transparent, covered by a thin test. Trunk is cylindrical with three anterior adhesive papillae. Specialised ectodermal cells are present in the papillae. They secrete a sticky substance with which the larva gets fixed to the substratum. The body is covered by large ectodermal cells.

The larva has well developed alimentary canal. It lies beneath the brain. Mouth is situated on the anterodorsal side and leads into the buccal cavity. Sac like branchial cavity (pharynx) develops three pairs of stigmata. An endostyle develops on pharynx which is midventral in position. Branchial sac opens into a short oesophagus which leads into a loop like intestine which opens into the anus. Anus opens into atrium which leads to the exterior through atrial pore. Pericardium encloses the heart. It lies below the posterior portion of the pharynx (Fig. 30.2)

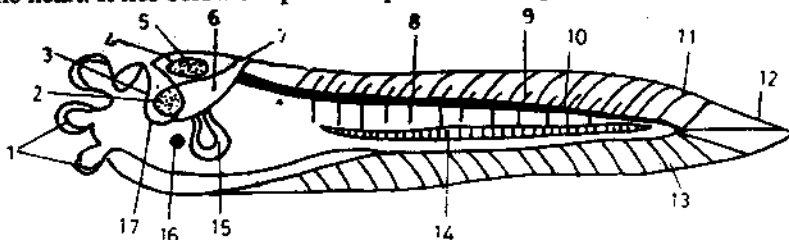

Fig. 30.2 *Herdmania*-Tadpole larva. 1. Adhesive papillae 2. Stigmata 3. Pharynx 4. Otocyst 5. Ocellus 6. Atrium 7. Atrial aperture 8. Nerve cord 9. Nerves 10. Tail ganglia 11. Tail fin 12. Tail 13. Myotomes 14. Notochord 15. Stomach 16. Heart 17. Endostyle.

Nerve cord, Notochord and Tail: Cerebral cone is present at the anterior most part formed by nerve cells. Sensory vesicle lies behind the cerebral cone. It has two ocelli (Photoreceptors) and an otocyst (balancing organ). The sensory vesicle may represent a rudimentary brain.

Visceral ganglion is present behind the sensory vesicle. It has ganglionic cells. "Spinal cord" extends from the visceral ganglion upto the tip of the tail. It may be compared to the spinal cord of higher chordates. It has ganglionic swellings which are metamericly arranged. Five paired nerves

arise from the entire tail. Notochord is made up of large vacuolated and turgid cells. These are developed from the endoderm. Notochord is present below the nerve cord and the vacuolated cells are arranged in a single row.

Tail is laterally compressed. The axial part of it is thick. The tail is provided with a tail fin which is broad and median. Tail possesses nerve cord, notochord and tail muscles. The tail fin has supporting fin rays. They are in the form of oblique striations. Three strong muscle bands are present in the tail. These present superficial segmentation as found in the myotomes of vertebrates.

Presence of tail with fin folds and fin rays, notochord, nerve cord, heart as a gut diverticulum, pharynx with perforations, muscle bands are **typical chordate characters**.

The larva swims actively for some time but because the mouth is closed it can not feed. It becomes geopositive i.e. it sinks to the bottom and fixes itself to a substratum and undergoes metamorphosis.

30.4 METAMORPHOSIS

During metamorphosis tremendous morphological changes takes place (Fig. 30.3).

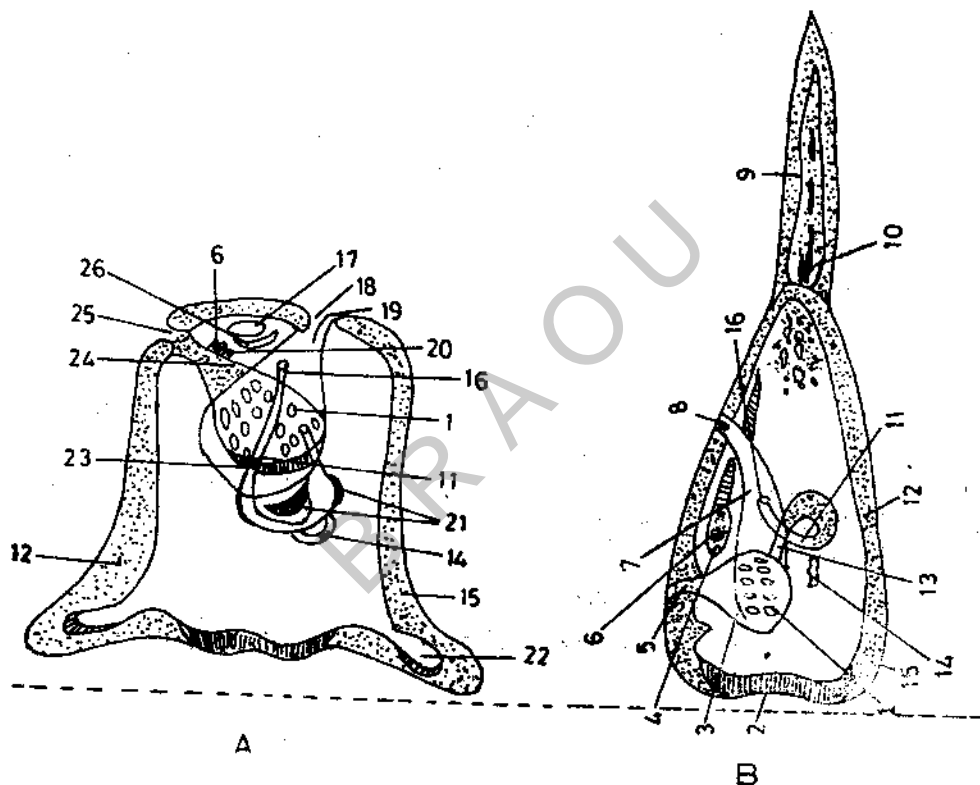

Fig. 30.3 *Herdmania*-Retrogressive metamorphosis. A. Tadpole larva undergoing retrogression. B. Adult, after completion of metamorphosis. 1. Stigmata 2. Adhesive papilla 3. Pharynx 4. Neural vesicle 5. Mouth 6. Hypophysial duct 7. Atrium 8. Atrial aperture 9. Degenerating tail 10. Notochord 11. Intestine 12. Mantle 13. Oesophagus 14. Heart 15. Test 16. Anus 17. Neural gland 18. Atrial aperture 19. Atrial siphon 20. Dorsal tubercle 21. Liver 22. Endodermal ampulla 23. Endostyle 24. Branchial siphon 25. Branchial aperture 26. Nerve ganglion.

1. **Tail:** Tail becomes short. This is achieved by two methods. Part of the tail is cast off and part of it is absorbed by phagocytes. Thus the notochord, nerve cord and muscle bands are all lost gradually.
2. **Test:** Tunicine is secreted by the larval ectodermal epithelium and thus the test is formed.
3. **Ampullae:** Four ectodermal ampullae are formed as prominent outgrowths along with the test. These help in respiration and in adhesion. Out of four two are big and two are small. The smaller ones are not developed in the other ascidians.

4. **Branchial Sac:** The wall of the branchial sac develops numerous gill slits. The sac shows enormous growth. The stomach grows to a large tubular structures. Intestine elongates and becomes curved. The liver lobes become prominent.
5. **Siphons:** The test invaginates into the branchial and atrial aperture to form branchial and atrial siphons respectively.
6. **Nervous System:** The cerebral vesicle with its ocelli and otolith degenerate. The entire nerve cord except visceral ganglion also disappears. Visceral ganglion modifies into visceral nerves. Neural gland develops from the anterior part of the cerebral vesicle. It communicates with the pharynx.
7. **Rotation of the Body:** The region of the body between the mouth and point of attachment to the substratum grows very rapidly resulting in rotation of the body in about 180°. The branchiopore and atriopore come to lie almost in the same plane i.e. at the distal end of the body.
8. Mouth loses its test covering. It allows continuous water current into the branchial sac.
9. Thick, tough and translucent test is formed around the body. It gives rise to foot.
10. Blood vessels and sinuses are formed and heart also completes its development.
11. Mesoderm develops gonoducts.

Thus active free swimming larva becomes a sedentary animal. The larva loses almost all chordate characters. Remaining few chordate characters are modified. The adult appears as a nonchordate. Contrary to the progressive metamorphosis, the larva, instead of acquiring advanced chordate characters loses all of them resulting in degeneration. This type of metamorphosis is called "retrogressive metamorphosis".

Significance: The free swimming larva is important because it is helpful in distribution to avoid intraspecific struggle (struggle between the same species).

30.5 AFFINITIES WITH CHORDATA

The free swimming tadpole larva possesses pharyngeal gill slits, dorsal hollow nerve cord extending in the entire length of the body and notochord in the tail region. These three are the typical chordate characters. This is the strong evidence to prove that tunicates are the true chordates. The eggs of some ascidians resemble those of *Amphioxus*. Cleavage and gastrulation are exactly similar in ascidians and chordates.

The adult ascidian also shows some chordate characters.

1. The branchial tentacles of a urochordate resemble the tentacles of *Amphioxus*.
2. The atrium of urochordate is similar to cephalochordata.
3. Presence of gill slits is similar in both the groups.
4. Ciliary-mucus feeding of urochordate is similar to that of cephalochordata and also similar to ammocoete larva of *Petromyzon*.
5. The endostyle of these animals may be homologous to vertebrate thyroid.
6. Neural gland and nerve ganglion together are homologous to pituitary body of vertebrates.

Specialized Characters

Urochordates possess some peculiar characters which are:

1. Many genera lead sedentary life.
2. Tunicine, which is allied to cellulose, is present in the test.
3. Coelom is absent or it is reduced to a large extent because of the extensive growth of atrium.
4. Presence of shuttle circulation i.e. reversal of flow of blood from time to time.
5. Larva undergoes retrogressive metamorphosis which is unique feature.

The resemblance between Urochordata and Hemichordata is insignificant. It is limited to the presence of pharyngeal gill slits. Adult ascidian is considered to be primitive than

cephalochordates. Absence of coelom and metamerism in Urochordata strengthens this view. Garstang in 1928 propounded a theory of chordate origin. This theory is supported by Berrill in 1955 and Romer 1959. This theory says that early ancestors of chordates were marine fixed and of filter feeding type.

The ascidians might have developed from pterobranchs, a group of Hemichordata. The tailed larva of early ascidians after a brief free life might have got fixed to a substratum and developed into inactive adult by retrogressive metamorphosis. Some scientists are under the impression that these tailed larvae are neotenic i.e. they develop gonads and do not metamorphose into adults. They might have gone to estuaries in search of rich food found there. They had to get accustomed to new circumstances. Therefore they developed some tremendous changes eg. powerful locomotory organs, muscles, efficient sense organs and excretory organs suited for fresh water life. They could live successfully after invading fresh water. According to this theory *Amphioxus* also has developed similarly.

The modern urochordates present primitive, degenerate chordate characters. As there is no fossil record of urochordates, their origin and phylogeny remain doubtful.

Check your progress

1. Ascidian tadpole larva has typical characters.
2. Endostyle is sometimes homologized with gland of vertebrates.
3. *Herdmania*, though placed in Animal Kingdom has substance in the test which is present in all plant cells.

30.6 SUMMARY

1. The cleavage result in coeloblastula.
2. Gastrulation results in two layered embryo.
3. The ectodermal cells differentiate to form medullary plate. Nerve cord is formed from this plate.
4. Notochord develops from the endodermal cells.
5. Mouth appears as an ectodermal invagination.
6. Ectodermal part behind the cerebral vesicle forms atrium.
7. Archenteron gives rise to alimentary canal.
8. Three adhesive papillae develop from the anterior region.
9. Test develops on the entire body surface.
10. Coelom is mesodermal in origin.
11. Extensive growth of atrium obliterates coelom.
12. Tail is absorbed by phagocytes. As a result of this all chordate characters are lost.
13. The body rotates at 180°.
14. Branchial and atrial apertures are formed.
15. Active free swimming larva metamorphosis into sedentary animal.

30.7 CHECK YOUR PROGRESS — MODEL ANSWERS

1. Chordate
2. Thyroid
3. Cellulose

30.8 MODEL EXAMINATION QUESTIONS

- I. Answer the following in about 30 lines
 1. Define retrogressive metamorphosis. Write the phenomenon in the animal you have studied.
 2. Discuss the affinities of Urochordata.
- II. Answer the following in about 10 lines.
 1. Tadpole of *Herdmania*.
 2. Gastrulation.

UNIT-31 SUBPHYLUM CEPHALOCHORDATA — AMPHIOXUS

Contents

- 31.1 Objectives
- 31.2 Introduction
- 31.3 General Characters of Cephalochordata
- 31.4 Classification
- 31.5 External Characters
 - 31.5.1 Body wall
 - 31.5.2 Musculature
 - 31.5.3 Skeleton
 - 31.5.4 Coelom
 - 31.5.5 General anatomy
- 31.6 Alimentary Canal
- 31.7 Respiratory System
- 31.8 Blood Vascular System
- 31.9 Excretory System
- 31.10 Nervous System
- 31.11 Sense Organs
- 31.12 Reproductive System
- 31.13 Summary
- 31.14 Check Your Progress — Model Answers
- 31.15 Model Examination Questions

31.1 OBJECTIVES

In this unit we shall discuss about the general anatomy of *Amphioxus* so as to explain the details about the primitive chordate features. At the end of this unit you can explain with interest, that *Amphioxus* is a peculiar animal as it shows the essential vertebrate characters like notochord, tubular nerve cord and pharyngeal 'gill slits'.

31.2 INTRODUCTION

Cephalochordata represent a generalised chordates except the headless state of organisation. Notochord extends into the anterior region ahead of the brain unlike other chordates. It becomes stiff and rod like that helps in burrowing and free swimming life. The best known genus is *Amphioxus* (= *Branchiostoma*) which is popularly called as Lancelet.

31.3 GENERAL CHARACTERS OF CEPHALOCHORDATA

1. These are marine solitary organisms of world wide distribution.
2. Body is fish-like, with burrowing and swimming habits.
3. Symmetry is present in *Amphioxus* but *Asymmetron* has no symmetry.
4. Cephalochordates lack head, brain, eyes, auditory apparatus and jaws i.e. there is no paired appendages.
5. Dorsal fin is in the form of low hollow fold of skin.
6. Caudal fin is in the form of lobes.
7. **Oral hood** is an outgrowth of the skin at the anterior ventral part of the body.
8. Attached to oral hood 10-20 pairs of stiff ciliated **buccal cirri** or oral cirri are present. These were mistaken to be branchiae or gills hence the name *Branchiostoma*.

9. Oral hood encloses a wide cavity called **vestibule**.
10. At the base of the vestibule a circular sphincter partition is present. It is called **velum**. It has velar tentacles. Enterostome is present at its centre.
11. The skin is thin, soft, translucent and is composed of columnar cells. Body wall consists of cuticle, epidermis and dermis.
12. **Myotomes** or **myomeres** are 'V' shaped blocks (50-85).
13. **Coelom** is obliterated by atrial or peribranchial cavity.
14. Pharyngeal wall has numerous **gill slits** which open into atrial cavity. A continuous water current is maintained for feeding and respiration. Water enters through mouth, goes to pharynx, then to atrial cavity and to exterior through **atriopore**.
15. **Hepatic caecum** is the only digestive gland.
16. Circulatory system is on chordate plan but blood is colourless.
17. Excretory system is in the form of **nephridia** which is the characteristic feature of Annelida.
18. Nervous system is as in vertebrates. It consists of hollow and tubular **dorsal nerve cord**. It is present above the notochord.
19. Sexes are separate. There are numerous gonads which are metamerically arranged. Gonoducts are absent.
20. Fertilization is external. Segmentation is complete. Larva is asymmetrical which **metamorphoses into symmetrical adult**.

Subphylum Cephalochordata consists of only one class, Cephalochorda. It is represented by two genera the *Amphioxus* and *Asymmetron*.

31.4 CLASSIFICATION

Phylum	Chordata
Sub Phylum	Cephalochordata (Acrania)
Family	Branchiostomatidae
Genus	<i>Amphioxus (Branchiostoma)</i>
Species	<i>A. lanceolatus</i>

Habit and Habitat: It is widely distributed. It is found in Mediterranean sea, Indian ocean etc. These are burrowing animals. It swims in the water actively. Mostly it is confined to shallow waters.

31.5 EXTERNAL CHARACTERS

It is a small, almost transparent animal and is less than 2 inches in length. The body is compressed, elongated at both ends. Extending along with the mid dorsal line, there is a longitudinal fold, the **dorsal fin**. The fin is continuous with the posterior **caudal fin**, which is a little wider. The **ventral fin** also extends from caudal fin to a little distance on the ventral side. At the anterior end, the dorsal fin is continuous with the **oral hood**. It is a frill like membrane. 10-12 **buccal cirri** or **oral cirri** are present on the ventral edge of the oral hood. The ventral flattened space between the oral hood and ventral fin is called **epipleur**. The lateral edges of the epipleur are called **metapleural folds** or **atrial folds**. The space enclosed by the oral hood is known as the **vestibule**. At the base of the vestibule there is a sphincter, **velum** which is circular in shape. Its centre bears an oval aperture called **enterostome**. The wall of the vestibule forms a **wheel organ**. It produces a whirling current which is vital for food collection. A ciliated **Hatschek's groove** is present on the roof of the vestibule (Fig. 31.1)

The **atriopore** is present where the two metapleural folds unite in the median line. The post anal portion is the tail. On the dorsal surface, near the anterior end **Kolliker's pit** is present. It is olfactory in function. The body can be divided into cephalic, atrial, post atrial or abdominal and caudal regions.

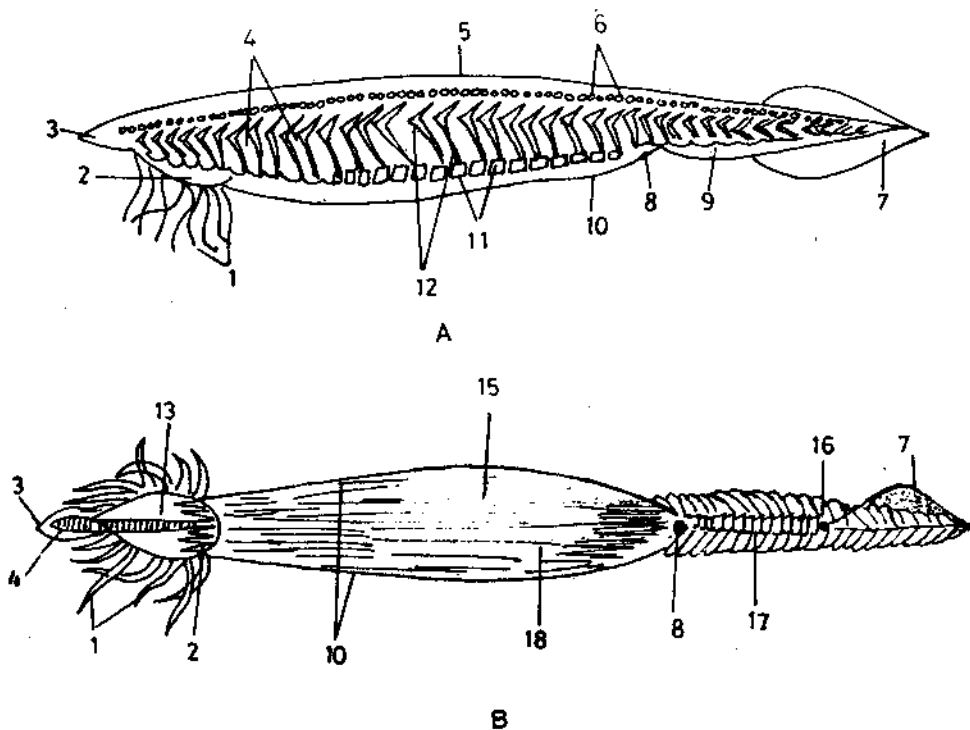

Fig. 31.1 *Amphioxus*-External features A. Lateral view B. Ventral view 1. Oral cirri 2. Oral hood 3. Rostrum 4. Myotomes 5. Dorsal fin 6. Dorsal fin ray boxes 7. Caudal fin 8. Atriopore 9. Ventral fin 10. Metapleural folds 11. Gonads 12. Myocommata 13. Vestibule 14. Notochord 15. Epipleur 16. Anus 17. Ventral fin rays 18. Ventral surface.

31.5.1 Body Wall

The body wall consists of epidermis formed of a single layer of columnar epithelial cells. Some of these cells are modified as nerve cells and some as unicellular glands. Cuticle is present on the epidermis. The epithelium of the buccal cirri possesses sensory cells. Some of them bear stiff sensory bristles while others bear cilia. Dermis is present beneath the epidermis. It is formed of connective tissue which contains nerve fibers and blood vessels.

31.5.2 Musculature

Muscular layer exhibits metameric segmentation. The muscles are very thick in the dorsal and dorso lateral region. There are about 60 myotomes or myomeres or muscle segments, the right side of which alter with the left side (They are not symmetrically opposite to each other). They are arranged in a linear series of 'V' shape apices of which are pointing forwards. Myotomes are enclosed in connective tissue sheaths called myocommata or myosepta. All the muscles are of voluntary type.

Contraction and relaxation of these myotomes bring about rapid movements either during swimming or during burrowing. The muscles are covered by the peritoneum and it is restricted to some places in the pharyngeal region.

31.5.3 Skeleton

Exoskeleton is absent in *Amphioxus*. Chief skeletal structures are notochord and gill bars. Notochord is a cylindrical rod tapering at both ends. It lies all along the length of the body over the digestive tract. Anteriorly it extends beyond the tip of the nerve cord and beyond the myotomes, hence the name of the subphylum Cephalochordata. Histologically, the notochord is composed of a peculiar notochordal tissue comprising large, disc like cells. In between the cells the fluid filled spaces are present, which give turgidity to notochord. It is surrounded by a fibrous connective tissue called the notochordal sheath.

The oral hood is supported by an annular ring made up of small cartilaginous pieces. Each buccal cirrus has one such supporting piece. It sends its own branch into the cirrus for support.

Numerous short broad connective tissue boxes or "fin rays boxes" support the dorsal and ventral fin folds. Dorsal fin possess single series of such masses where as ventral fin has two series.

Gill bars are supported by the delicate, skeletal gill rods made up of stiff gelatinous tissue and elastic fibres. The details of the gill bars shall be discussed along with the structure of pharynx in the digestive system.

31.5.4 Coelom

Amphioxus, like the vertebrates, possesses a true coelom or enterocoel derived from archenteron. It is spacious in the intestinal region. It is reduced in pharyngeal region and is confined to a pair of dorso-lateral longitudinal channel one on each side of the pharynx. A single sub endostylar channel is present on the mid ventral side. This channel is connected to dorso-lateral channels by ventral coelomic canals passing through primary gill bars.

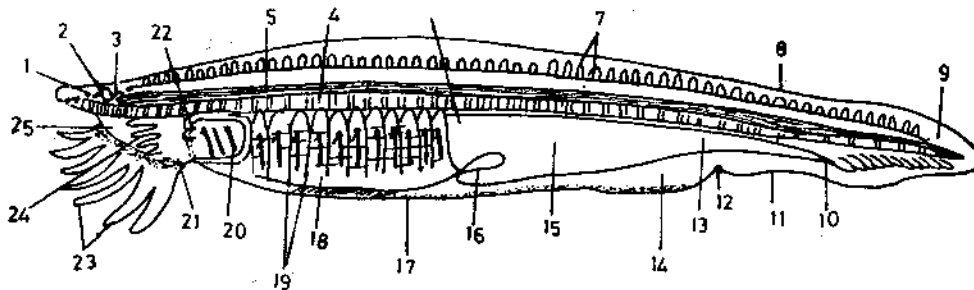

Fig. 31.2 *Amphioxus*-Internal structure. 1. Eye spot 2. Olfactory pit 3. Cerebral vesicle 4. Notochord 5. Nerve cord 6. Oesophagus 7. Dorsal fin ray boxes 8. Dorsal fin 9. Caudal fin 10. Anus 11. Ventral fin 12. Atripore 13. Hind gut 14. Atrium 15. Midgut 16. Midgut diverticulum 17. Metapleural folds 18. Pharynx 19. Primary secondary gill bars 20. Gill slit 21. Oral hood 22. Enterostome 23. Oral cirri 24. Wheel organ 25. Velum.

31.5.5 General Anatomy

Atrium is a spacious peribranchial cavity and surrounds the pharynx. The atrium is lined by the ectoderm and communicates with the exterior through **atripore**. Atrium extends anteriorly and posteriorly to form blind pouches. It gives out a pair of channels into dorsal coelomic canals at the posterior part of pharynx. These are called **brown funnels** or atrio coelomic canals. Atrial cavity is a part of the ectoderm shut in by the flap like metapleural folds and hence the lining is epidermal (Fig. 31.2 & Fig. 31.3).

31.6 ALIMENTARY CANAL

The alimentary cannal is a straight tube with various diameters. It is suspended by a **dorsal mesentery**. It can be conveniently divided into mouth, buccal cavity or vestibule, pharynx, oesophagus, intestine, anus and associated digestive glands.

The mouth is the wide aperture at the anterior end enclosed by oral hood. It is only stomodaeal part of the alimentary canal. Oral hood has 10 to 12 pairs of stiff and slender processes called the oral cirri or buccal cirri. They bear minute sensory papillae. The cirri form a sieve during feeding.

The oral hood encloses a wide cavity called **vestibule** or **buccal cavity**. A circular aperture called **enterostome** leads vestibule into the **pharynx**. The enterostome is surrounded by **velum**. The wall of the vestibule is raised into number of thick finger like ciliated ridges called the **wheel organ of Muller**. It produces a continuous whirling current in the vestibule. In the mid dorsal ridge of the wheel organ the vestibular wall has a glandular **Hatschek's groove** or pit which secretes mucus.

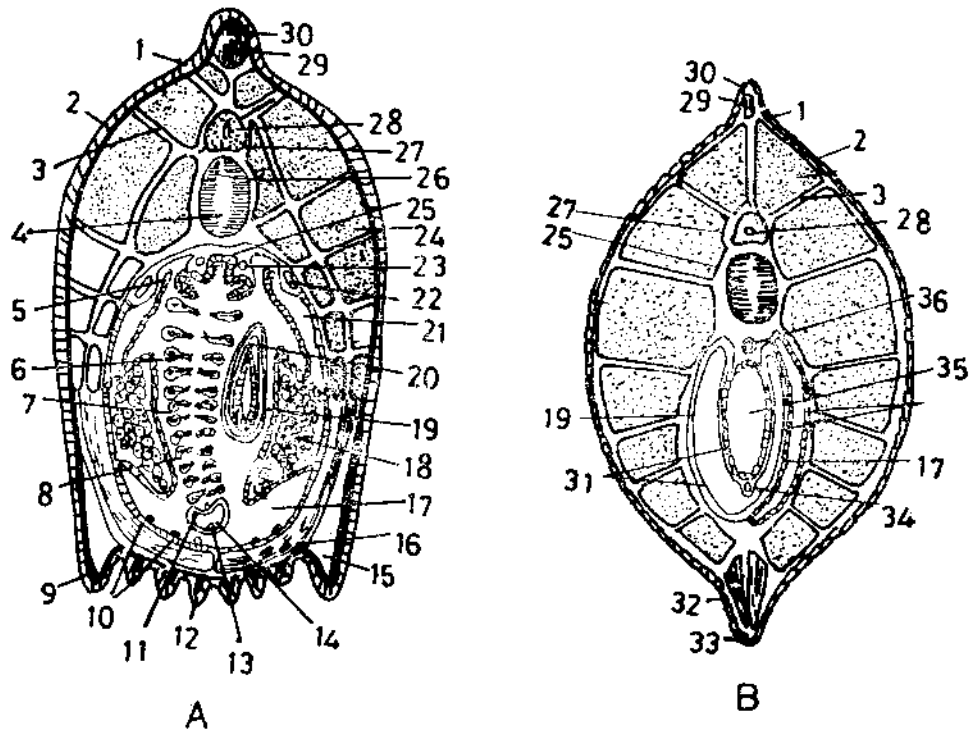

Fig. 31.3 T.S. of *Amphioxus*. A. Passing through pharyngeal region. B. Passing through intestinal region. 1. Epidermis 2. Dermis 3. Myocomma 4. Notochordal sheath 5. Nephridium. 6. Gill bar 7. Gill slit. 8. Pharynx. 9. Metapleural fold. 10. Renal papillae 11. Endostyle 12. Epipleur 13. Ventral aorta 14. Subendostylar coelom 15. Lymph space 16. Transverse muscle 17. Atrium 18. Gonad (ovary) 19. Coelom 20. Midgut diverticulum 21. Dorsal coelomic canal 22. Brown funnel 23. Lateral dorsal aorta 24. Myomere 25. Epipharyngeal groove 26. Notochord 27. Nerve cord 28. Neurocoel 29. Dorsal fin ray box 30. Dorsal fin 31. Peritoneum 32. Ventral fin ray boxes 33. Ventral fin 34. Sub intestinal vessel 35. Intestine 36. Median dorsal aorta.

Enterostome is guarded by a sphincter in the velum. Velum has 6 pairs of velar tentacles. They form an efficient sieve during feeding.

Pharynx is the largest and widest part of the alimentary canal occupying nearly half of the body. It is laterally compressed. Its wall is perforated by about 150 narrow, gill slits or branchial apertures. Pharynx communicates with atrium through these apertures. The 'U' shaped gill slits are separated by gill bars or branchial lamellae which are of 2 types, primary and secondary. Both these types alternate with each other

The primary bars are formed in the larva and during the development the secondary gill bars are

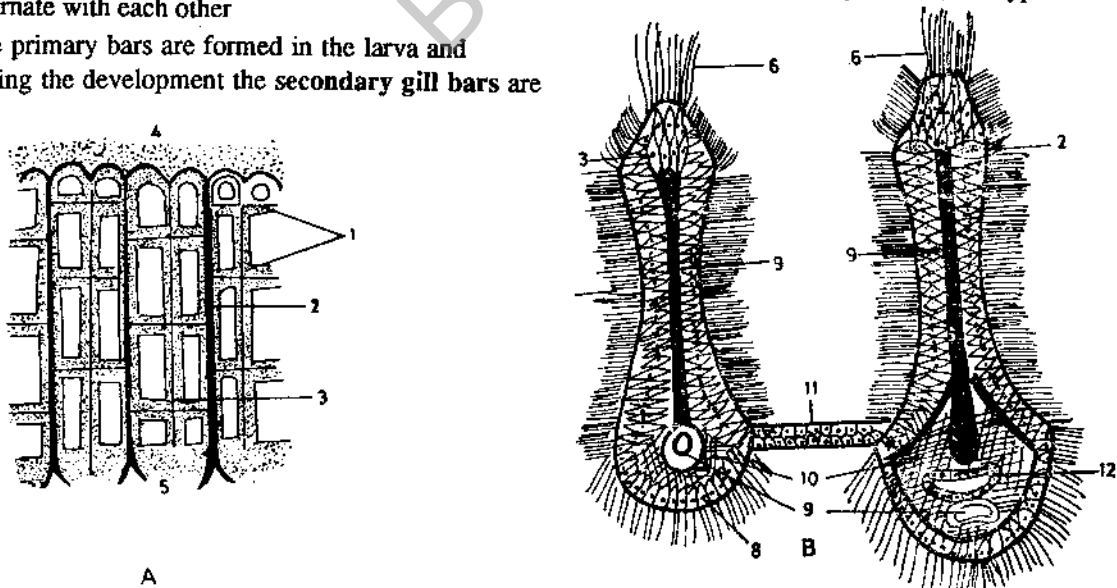

Fig. 31.4 *Amphioxus*. A. Primary and secondary gill bars with synapticulae. B. T.S. Primary and secondary gill bar. 1. Synapticulae 2. Primary gill bar 3. Secondary gill bar 4. Dorsal side 5. Ventral side 6. Tuft of frontal cilia 7. Lateral cilia 8. Epithelium of atrium 9. Blood vessel 10. Skeletal rod 11. Synapticulum 12. Coelomic canal.

formed. The primary and secondary bars are inter connected by numerous short horizontal bars (31.4A). Due to synapticulae the pharyngeal wall becomes complicated basket like structure. Each bar (both primary and secondary) is supported by a skeletal rod. It is made up of stiff gelatinous tissue. The rods of the primary bars are forked at their free ventral ends. Each gill bar is formed partly of the pharyngeal wall and partly of the body wall. Each primary gill bar encloses a narrow coelomic space. The primary and secondary gill bars are richly covered by ciliated epithelium. The cilia on the pharyngeal side are notably long and are called the frontal cilia. The cilia of anterior and posterior surfaces are called lateral cilia.

In the larval stages the number of gill slits correspond with the myotomes but as the animal grows the number will increase. The midventral groove of the pharyngeal wall is called endostyle or hypopharyngeal groove.

The mid dorsal groove of the pharyngeal wall is called epipharyngeal groove. Its epithelium is ciliated. At anterior end of pharynx the endostyle and the epipharyngeal groove are connected together by means of peripharyngeal bands. These are ciliated.

The pharynx leads into the oesophagus. It is a short narrow and ciliated structure which leads into intestine.

Intestine can be divided into midgut and hindgut. The midgut gives out a club shaped blind pouch like midventral diverticulum called midgut diverticulum or hepatic caecum or "liver" which projects into the atrium. It is lined by an enzyme secreting glandular epithelium. This is the only digestive gland present in *Amphioxus*. It secrets digestive enzymes protease, amylase and lipase. Posterior part of the midgut possesses ilio-colonic ring which is heavily ciliated. The cilia of the entire tract beat constantly. The ciliary action helps the food cord to rotate on its longitudinal axis. Numerous cilia are present at the posterior end of the hindgut. Hindgut is also called rectum which opens out by anus. Anus is present on the ventral side at the base of the caudal fin. It is a circular aperture and is controlled by sphincter (Fig. 31.5).

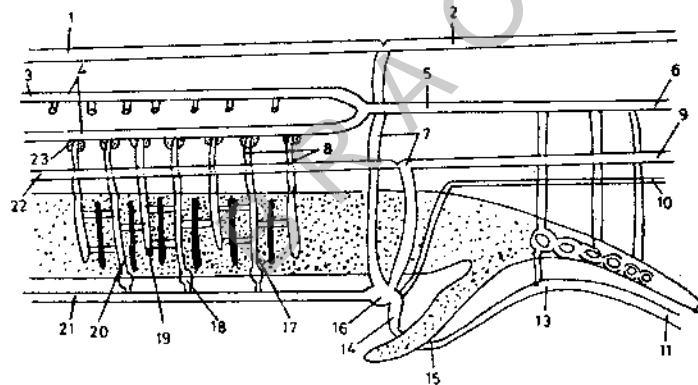

Fig. 31.5 *Amphioxus* - Alimentary canal (arrows show movement of food). 1. Buccal cirri 2. Wheel organ 3. Velar tentacles 4. Vestibule 5. Enterostome 6. Midgut diverticulum 7. Food cord 8. Area of ilio-colonic ring. 9. Anus 10. Area of hindgut 11. Ciliated tract 12. Oesophageal region 13. Gill slits 14. Pharyngeal region.

Mode of Feeding: The mechanism of ciliary feeding (filter feeding) in *Amphioxus* is complicated. The cilia are responsible for creating a continuous water current. The food consists of diatoms, small protozoans, desmids, larvae etc. The water current enters the mouth, buccal cavity, enterostome, pharynx and goes to atrium through gill slits and to the exterior through atriopore. The buccal cirri, oral hood, wheel organ, velum and velar tentacles help as accessory organs in the ciliary feeding. They form a mesh to filter the food particles.

When the debris settles near the velar tentacles and oral cirri, the reverse current clears them immediately. First the atriopore closes, the floor of the atrium raises, pharynx compresses. The water goes out violently through the vestibule cleaning velar tentacles and oral cirri.

The food material in the pharynx is entangled in the mucus secreted by the endostyle. The mucus with food particles passes into epipharyngeal groove. The cilia of the groove beat backwards so that the mucus cord is pushed into the oesophagus. Some bigger particles drop out into the oral hood.

The whirling current of the wheel organ prevents them to clog. The mucus secreted by Hatschek's groove entangles these particles. Food laden mucus enters the enterostome along with main water current.

Physiology of Digestion: The food-mucus cord enters into the oesophagus and midgut by the action of cilia. Then it passes into the ilio-colonic ring where it is rotated thoroughly by cilia. Digestive enzymes (Amylase, lipase and protease) of midgut diverticulum and midgut digest food material. The process of digestion continues even in the intestine. Intracellular digestion takes place in midgut diverticulum. Absorption of the digested food takes place in the hindgut. Intracellular digestion and phagocytosis are noteworthy in *Amphioxus* as they are totally absent in higher vertebrates.

31.7 RESPIRATORY SYSTEM

There are no special respiratory organs in *Amphioxus*. Pharynx plays a minor role in respiration as the blood has no respiratory pigment. The heavily ciliated pharynx requires sufficient quantity of oxygen which may be met with the blood vessels (Afferent branchial arteries) entering the pharyngeal gill bars. Pharynx is chiefly food collecting organ.

Exchange of gases takes place by diffusion through the entire body surface.

31.8 BLOOD VASCULAR SYSTEM

The blood vascular system of *Amphioxus* is very simple. It is of closed type. There is no distinct heart and the blood lacks a respiratory pigment (Haemoglobin). The blood is colourless and a few white blood corpuscles are present. The blood vessels are very simple. Capillary system is lacking. Yet the entire system is based on the fundamental chordate plan.

At the posterior end of the pharynx on ventral side, there is a simple bulb like sinus venosus. It collects blood from all parts of the body. The chief blood vessels are ventral aorta, dorsal aortae, subintestinal vein, hepatic portal, hepatic veins and cardinal veins (Fig. 34.6).

Ventral Aorta: Ventral aorta (Endostylar aorta) arises from sinus venosus and runs beneath the pharynx mid ventrally in the subendostylar regions. This vessel is highly contractile and contracts rhythmically so that blood flows in the forward direction. Numerous paired lateral branches called afferent branchial vessels are given off from the ventral vessel into the primary gill bars. Each afferent branchial artery at the base of gill bar dilates into a bulb or bulbule. It has contractile nature and may act as branchial heart. The vessels of the synapticalae connect the afferent branchial

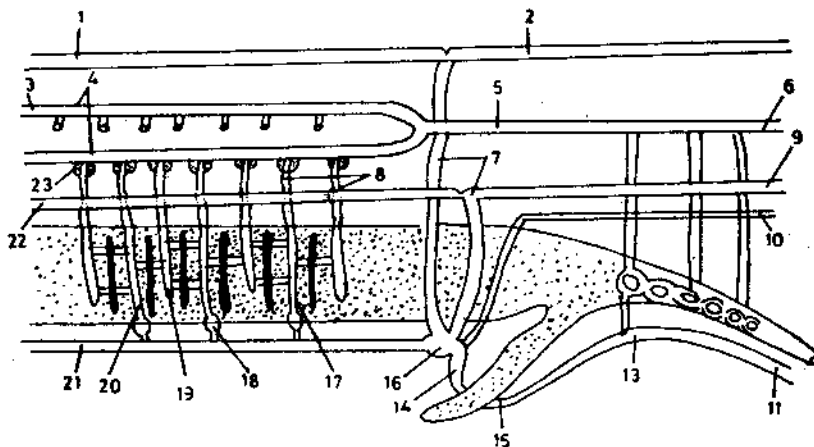

Fig. 31.6 *Amphioxus* - Blood vascular system. 1. Right anterior cardinal vein 2. Right posterior cardinal vein 3. Carotid artery 4. Lateral dorsal aorate 5. Median dorsal aorta 6. Caudal artery 7. Ducts or Cuvieri 8. Efferent branchial arteries 9. Left posterior cardinal vein 10. Parietal vein 11. Caudal vein 12. Intestinal capillaries 13. Sub-intestinal vein 14. Hepatic vein 15. Hepatic portal vein 16. Sinus venosus 17. Primary afferent branchial artery 18. Bulbule 19. Secondary afferent branchial artery 20. Afferent branchial arteries 21. Ventral aorta 22. Left arteries 23. Glomus.

vessels of primary gill bars with the vessels of the secondary gill bars. Thus it is evident that the vessels of the secondary bars do not communicate with the ventral aorta directly. The arteries of primary and secondary gill bars do not break up into capillaries. They emerge out as efferent branchial arteries and unite to form lateral dorsal aortae one on each side. Each afferent artery breaks up into a blood plexus or net work called **glomus** just before opening into the dorsal aorta of its side. The **glomus** lies near the nephridium (Excretory organ).

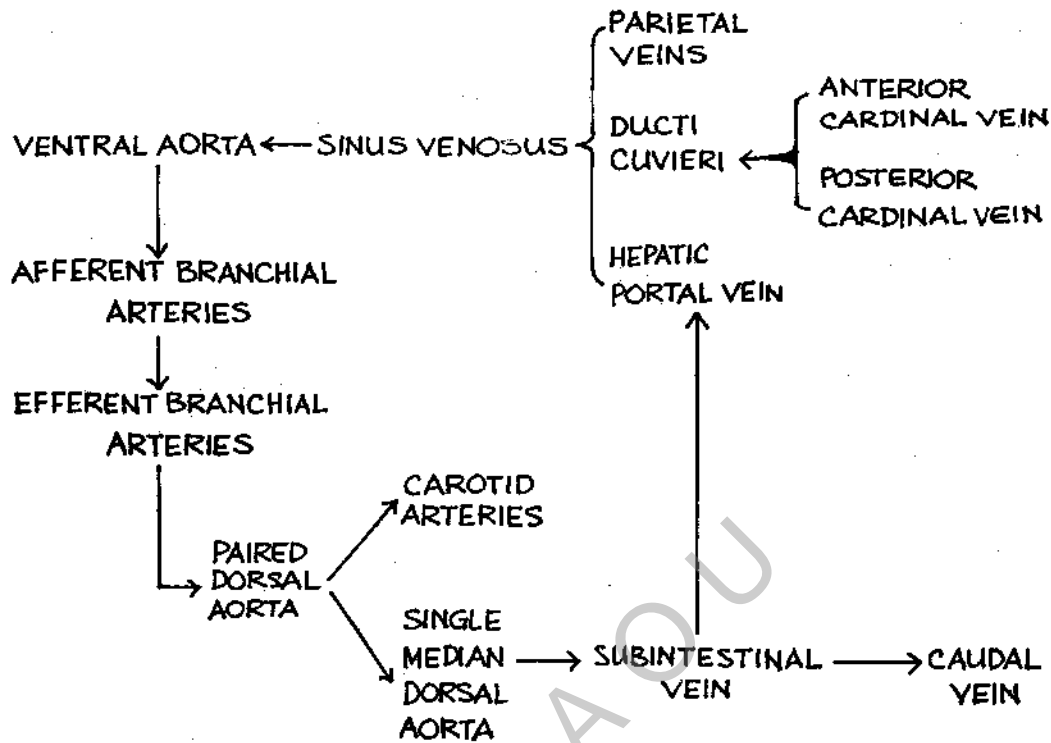

Fig. 31.7 *Amphioxus* — Course of blood circulation.

Dorsal aorta: The lateral dorsal aortae, lie one on either side of the epipharyngeal groove. Each dorsal aorta runs forward as carotid artery to supply blood to oral hood. The two lateral aortae, behind the pharynx unite together to form median dorsal aorta which runs beneath the notochord through the dorsal mesentery. The dorsal aorta gives off segmental arteries to myotomes and some arteries to the intestine. It continues into the tail as caudal artery. In the intestinal walls the arteries break up to form a plexus of microscopic capillary like vessels.

Subintestinal vessel, Hepatic portal and Hepatic veins: The capillary like vessels collect the blood and pour into a median longitudinal vessel called subintestinal vein. It lies beneath the intestine. In this trunk the blood flows forwards. The subintestinal vein turns to the right and enters into the wall of the midgut diverticulum or hepatic caecum or 'liver' and ramify into plexus. This may be considered as primitive hepatic portal system which is very well developed in vertebrates. A short hepatic vein collects the blood from the capillary like vessels of midgut of diverticulum and opens into the sinus venosus or venous sinus. The caudal veins from the tail join the vessels of the gut wall.

Cardinal veins: The blood from the myotomes and body wall is collected on either side by a pair of posterior cardinal veins. These cardinal veins run in the dorsal wall of the coelom and unite to form the ducti Cuvieri. Both Cuvierian ducts opens into sinus venosus.

The blood from the dorsal body wall is collected by a pair of parietal veins, which run above the intestine and open into the sinus venosus. The main function of the blood is the transportation of food material and plays a very little role in transport of oxygen.

31.9 EXCRETORY SYSTEM

Excretory system consists of **nephridia** (Protonephridia) each possessing numerous **solenocytes** or **flame cells**. The nephridia are segmentally arranged on the pharynx. They are in single series numbering about hundred pairs. Each nephridium is very small in size and is a closed tubule. It is partly ciliated and partly glandular and possesses thin wall. It is bent at right angle and possesses long vertical limb and a short horizontal limb. The vertical (Anterior) limb ends blindly. It lies in the coelomic canal of the primary gill bar. On the ventral surface of the horizontal limb there is a small aperture called **nephridiopore**. It opens into the atrium opposite to the secondary gill bar. Each nephridium has about 500 solenocytes. These are born on caecae like projections. All these are directly dipped in the coelomic fluid.

Each solenocyte is unicellular which ends in a knob like structure called cell body (Fig. 31.8). It has a nucleus and long slender duct with a flagellum of flickering type called **flame**. The ducts of all solenocytes open into the lumen of nephridium.

Efferent branchial artery forms a **glomerulus** near the nephridium in the dorsal coelomic canal.. The atrio coelomic channels or brown funnels are also supposed to be excretory in nature. They are large tube like structures situated on the dorsal side of the pharynx.

The nephridium of Hatschek is a large, narrow tube like structure. It is situated on the pharynx. Posteriorly it opens into the pharynx just behind the velum and in the anterior part it ends blindly in the Hatschek's pit.

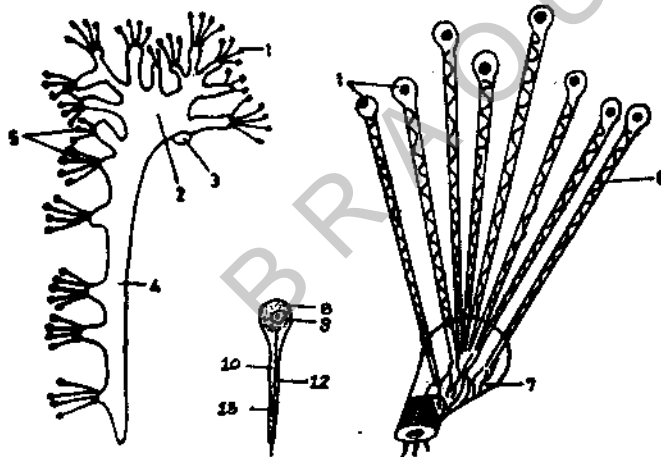

Fig. 31.8 *Amphioxus*. A. Nephridium. B. A part of the nephridium magnified C. Single solenocyte 1. Solenocyte 2. Horizontal limb 3. Nephridiopore. 4. Vertical limb 5. Caeca 6. Flagellum 7. Caecum 8. Cell body 9. Nucleus 10. Lumen 11. Tubule 12. Flagellum 13. Free flagellum.

Renal papillae are small groups of columnar epithelial cells present on the atrium. These may be excretory in function.

Mechanism of excretion is not clearly understood Nitrogenous waste products from the glomerular blood diffuse into the coelomic fluid. From there, they pass into the solenocytes of the nephridium. The vibratile flagella carry them to the atrium from where they are thrown out along with the outgoing water. Nephridia probably serve as osmoregulatory organs also.

31.10 NERVOUS SYSTEM

The nervous system consists of central, peripheral and autonomic nervous divisions based on typical vertebral plan.

Central nervous system: It consists of neural tube which lies in the mid dorsal line just above the notochord. It runs almost full length of the body. It is roughly triangular in transverse section. It encloses a narrow cavity, the neurocel or central canal which is filled with cerebro spinal fluid. At its anterior end the central canal expands to form cerebral vesicle but the external diameter of the cord does not change. A small outgrowth, the diverticulum, arises from the cerebral vesicle and extends over the central canal. The **infundibular organ** is present on the floor of the cerebral vesicle. The cerebral vesicle communicates with the exterior by a neuropore in the young but closes when it grows to adult. The ependyma (a layer of non nervous cells) is close to the central canal and is surrounded by a layer of nerve cells or grey matter. This is surrounded by a layer of longitudinal non medullated nerve fibres called 'white matter'. This arrangement is found in typical vertebrates. Cell bodies of the neurons are grouped around the central canal, as in the vertebrates. The nerve cells are of 2 types:

1. Small cells whose processes pass into the peripheral nerves.
2. Giant cells which are very large and multipolar occur at intervals in between the ordinary cells. Giant cells possess extremely long and thick dendrites. These cells and fibres are similar to those of Annelida and crustaceans and coordinate the locomotion.

Peripheral nervous system: The peripheral nervous system consists of two pairs of cerebral or cranial nerves. These arise from the cerebral vesicle and a set of number of spinal nerves from the remaining nerve cord. Two pairs of the cerebral nerves or dorsal roots arise from the sensory parts of sense organs of the snout, oral hood, oral cirri and carry sensory impulses to nerve cord and thus they are sensory in nature. There are no corresponding ventral roots in the cephalic region. From the dorsal nerve cord, a dorsal and ventral root are given off on each side to every segment. The roots are not united where as in higher chordates they unite. Each ventral root carries motor fibres to a myotome. These fibres terminate on muscle fibres at motor end plates like those of vertebrates. The dorsal roots of one side are opposite to the ventral roots of the other side thus exhibiting asymmetry.

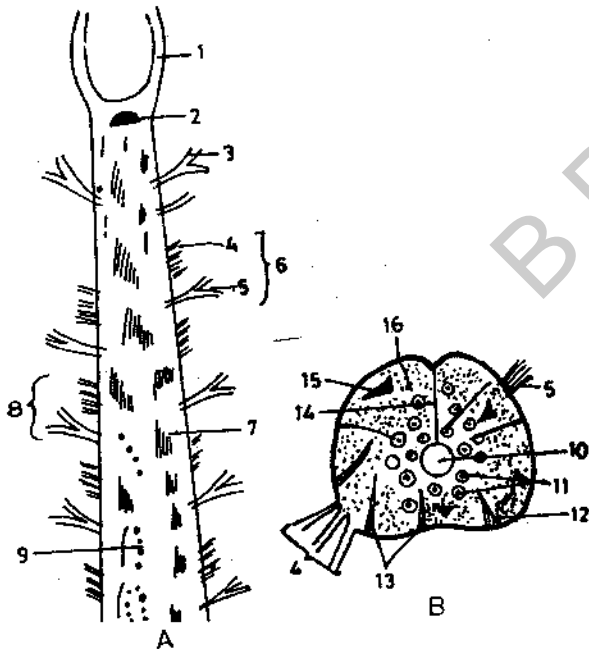

Fig. 31.9 *Amphioxus* - Nervous system. A. Anterior portion of nerve cord with cerebral and spinal nerves. B. T.S. of Nerve cord.

1. First cerebral nerve
2. Cephalic pigment spot
3. Second cerebral nerve
4. Ventral root
5. Dorsal root
6. First spinal nerve
7. Nerve cord
8. Second spinal nerve
9. Ocelli
10. Central canal
11. Nerve cells
12. Nerve fibres
13. Supporting fibres
14. Dorsal tissue.
15. Giant fibres
16. Sheath.

Autonomic nervous system: It controls the involuntary muscles of the gut wall, where two nerve plexi are present. These communicate with the nerve cord by visceral nerves in the dorsal roots. The walls of the atrium contain neurons below the epithelium. These have connections with the central nervous system and may be sensory and also motor in nature. Ganglia are not formed.

31.11 SENSE ORGANS

The sense organs of *Amphioxus* are few and simple. Olfactory pit (Kolliker's pit), median central eye or cephalic pigment spot and the infundibular organ are associated with cerebral vesicle. Ocelli are found on the nerve cord. Tangoreceptors are on the integument, chemoreceptors are present on buccal cirri and Hatschek's groove. Sensory cells are found in the muscles.

Olfactory pit or Kolliker's pit: It is situated on the left side of anterodorsal region of cerebral vesicle. It is a pit like depression lined by ectodermal ciliated epithelium but no sensory cells are found. It communicates with the cerebral vesicle through a neuropore. Some scientists consider it to be a chemoreceptor.

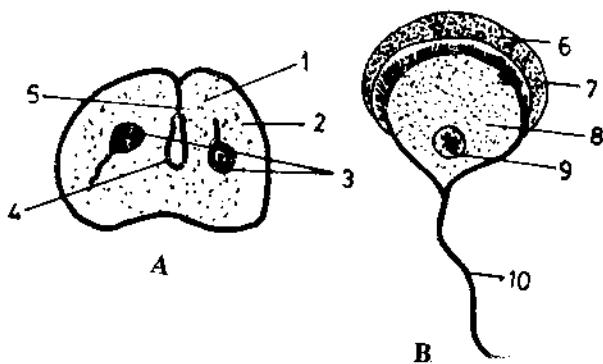

Fig. 31.9 *Amphioxus*. A. T.S. of nerve cord with ocelli. B. A single ocellus magnified

1. Nerve cells
2. Nerve cord
3. Ocelli
4. Central canal
5. Dorsal tissue
6. Pigment cells
7. Apical border
8. Lens like mass
9. Nucleus
10. Nerve fibre

Median eye or Cephalic pigment spot: It is a large spot present in the anterior end of cerebral vesicle. The lens and other accessory structures of the typical eye are absent, as a result it is not photosensitive. Probably it may serve to prevent the light. Some workers consider it to be thermoreceptor.

Ocelli or Eye spots: These are present on the nerve cord and are sensitive to light. Each ocellus consists of two cells, a blackish brown cup shaped pigment cells, forming a cap above and a lens like photosensitive cell below. This gives striated appearance and may act as a lens (Fig. 31.9).

The ocelli send fine fibres to the nerve cord and are arranged asymmetrically in two rows in the ventrolateral side. The asymmetrical arrangement of the ocelli may result in one sided perception of light and this may be responsible for spiral movements of the animal.

Infundibulum: It is a patch lined by tall ciliated columnar cells in the floor of the cerebral vesicle. Previously it was thought to be homologous to infundibulum of vertebrates but now it is regarded as an eye like structure. Modern workers consider it to be secretory in nature.

Tangoreceptors or Sensory cells of integument: These are numerous, scattered in the epidermal cells of the integument. These are plenty in the ectoderm of dorsal surface. Each sensory cell is slender spindle like and bears at its free end a small hair like process of sensory nature. The other end is conducted to a nerve fibre which is connected to the dorsal root of nerve cord. These cells are tactile and may test the nature of the sand.

Sensory papillae: Some sensory cells possessing sensory bristles or cilia form minute papillae. These are present on the buccal and velar tentacles. The papillae of buccal cirri are tactile and those of velar tentacles are chemoreceptors.

Hatschek's groove present in the roof of the vestibule may be gustatoreceptor (Organ of taste).

The sensory cells present in the gut may be chemoreceptors. Numerous free nerve endings are present in the muscles. These are sensitive to internal stimuli and are called proprioceptors.

31.12 REPRODUCTIVE SYSTEM

Amphioxus is unisexual i.e. sexes are separate as in higher chordates but there is no sexual dimorphism (males and females can not be distinguished externally).

The gonads, the testes or ovaries as the case may be, are about 26 pairs with metameric arrangement. They are arranged in two rows in the ventro lateral body wall in the pharyngeal region and project into the atrium. The gonoducts are absent. The mature spermatozoa or ova are shed into the atrium by rupture of coelomic and atrial epithelia. The temporary pore closes soon after the gametes are shed. The places of rupture are called cicatrices. The gametes reach the atrium and escape into the sea water through atriopore. The fertilization and development are external.

Check Your Progress

1. *Amphioxus* is a ciliary feeder. This function is performed by various accessory organs like and
2. is a common structure in *Herdmania* and *Amphioxus* to entangle and deflect the food particles by its ciliary action.
3. Muscle blocks known as arranged in a linear series exhibit in *Amphioxus*.

31.13 SUMMARY

Cephalochordates possess a well developed permanent notochord. Anteriorly it extends beyond nerve cord, hence the name of the subphylum cephalochordata. Cephalochordates are marine, solitary organisms. They are cosmopolitan in distribution. *Amphioxus* is a typical example of this subphylum. Special structures like oral hood, vestibule, velum, velar tentacles, Wheel organs. Hatschek groove etc., are present. Nervous and blood vascular systems are based on chordate plan. Excretory system is in the form of nephridia sexes are separate but no sexual dimorphism.

31.14 CHECK YOUR PROGRESS - MODEL ANSWERS

1. Buccal Cirri, Oral hood, Wheel Organ, Velum and Velar Tentacles.
2. Endostyle
3. Myotomes, Metameric Segmentation.

31.15 MODEL EXAMINATION QUESTIONS

I. Answer the following in about 30 lines each

1. Give an account of external features of *Amphioxus*.
2. Describe the digestive system and digestion in *Amphioxus*.
3. Describe the respiratory system of *Branchiostoma (Amphioxus)*.
4. Describe the circulatory system of *Amphioxus* mentioning the specialities of the system.
5. Write in detail the excretory system of *Branchiostoma*.

II. Answer the following in about 10 lines each.

1. Coelom 2. Atrium 3. Feeding 4. T.S. Through pharynx 5. T.S. Through intestine 6. Sense organs.

UNIT-32 AFFINITIES OF AMPHIOXUS

Contents

- 32.1 Objectives
- 32.2 Introduction
- 32.3 Chordate Characters
- 32.4 The Vertebrate Affinities
- 32.5 Primitive Characters
- 32.6 Specialized Characters
- 32.7 Summary
- 32.8 Check Your Progress — Model Answers
- 32.9 Model Examination Questions

32.1 OBJECTIVES

The relationship existing between *Amphioxus* and other chordates especially, the primitive characters of *Amphioxus* are discussed. A critical study of this unit will help you to explain lucidly the interrelationships of *Amphioxus* with chordates, vertebrates in addition to its own adaptive characters and retaining a few primitive characters.

32.2 INTRODUCTION

Because of its resemblances with various diversified groups of animals the position of *Amphioxus* stands unique. Had the *Amphioxus* not been discovered no wonder the zoologists would perhaps, be compelled to invent an *Amphioxus* like hypothetical animal in order to establish a sequential evolutionary line of chordates. It expresses neatly the origin of an ideal chordate from a chordate like ancestor.

32.3 CHORDATE CHARACTERS

Amphioxus shows three fundamental chordate characters namely presence of **notochord**, **dorsal tubular nerve cord** and **perforated pharynx**.

32.4 THE VERTEBRATES AFFINITIES

1. The body of *Amphioxus* resembles that of a fish.
2. Presence of post anal region or tail.
3. Mouth is anterior and is on the ventral side.
4. Presence of median fin folds.
5. Presence of metapleural folds (In the embryo of the fish similar folds are present from which the paired fins are developed).
6. Presence of segmentally arranged myotomes
7. True coelom is of mesodermal origin.
8. Backward blood flow in dorsal vessel and forward flow in the ventral vessel.
9. Presence of hepatic portal system.
10. Presence of so called "Liver" or midgut or hepatic diverticulum which can be compared to liver of higher vertebrates.
11. Skin is two layered.
12. The origin and general plan of nervous system.
13. The general development of the zygote.

32.5 PRIMITIVE CHARACTERS

1. Lack of cephalization and paired appendages as in many invertebrates.
2. Asymmetry of the body as found in echinoderms.
3. Metameric segmentation is total as in Annelida. Myomeres, in particular, show complete metamerism from anterior end to posterior end.
4. Single celled thick epidermis is found as in Annelida. In Vertebrata the epidermis is modified into stratified epithelium.
5. There is no endoskeleton made up of cartilage and bone.
6. Endostyle is found in Urochordata, Cephalochordata and Ammocoete larva (larva of *Petromyzon*). It plays a very important role in feeding. In adult *Petromyzon* and other vertebrates this gets modified into thyroid gland.
7. Formation of nervous system and notochord are chiefly of urochordate type.
8. Central nervous system is of primitive type with a very little differentiation of brain. Dorsal and ventral roots are separate with unequal number and no symmetry in their arrangement.
9. Endostyle, epipharyngeal groove, peripharyngeal bands which are useful in filter feeding are similar in urochordates and cephalochordates. Evidently this type of feeding is primitive character as it is found in Ammocoete larva of Lamprey, Enteropneusta and the larvae of Amphibians.
10. Straight gut is the typical character of non-chordates. Vertebrates have looped or coiled intestine as digestive system is longer than the body itself. Only hepatic diverticulum of secretory nature is present. In vertebrates liver and pancreas are present.
11. Coelom of *Amphioxus* resembles with that of echinoderm as it develops from archenteron in both (Enterocoelous coelom). Vertebrates have modified type of enterocoelous coelom.
12. The respiratory system with typical branchial basket is exactly same as in *Balanoglossus* (Hemichordata).
13. Excretory system shows striking resemblance with Annelids and flat worms.
14. Notochord is persistent throughout life in *Amphioxus*. Where as in vertebrates it gets modified partly fully into vertebral column.
15. There are no paired sense organs as auditory organ, eyes, nares etc.
16. There is no cephalization probably because of extensive growth of notochord into the head (hence the name Cephalochordata). Thus the animal does not possess skull, true brain and cephalic paired sense organs.
17. It does not possess kidney. The typical annelidan character of having protonephridia is retained. The vertebrates possess kidney of mesodermal origin.
18. Blood vascular system of *Amphioxus* is also primitive as there is no heart and blood vessels, not differentiated well into arteries and veins. There is no respiratory pigment.
19. Gonads are many and are arranged segmentally. Gonoducts are absent. This is a nonchordate character as vertebrates possess highly reduced number of gonads and well formed gonoducts.

32.6 SPECIALIZED CHARACTERS

1. **Notochord:** Notochord is longer than the nerve cord. The over development of it is helpful for swift burrowing. Probably this over growth is responsible for acephalic condition (lack of head).
2. **Atrium:** Extensive growth of atrium is to protect the delicate pharynx.
3. **Asymmetry:** Most of the organs show characteristic asymmetrical condition eg. Myomeres and nerves.
4. **Oral hood with Vestibule:** Oral hood with buccal cirri, velar tentacles are well developed for filter feeding mechanism. Presence of wheel organ or organ of Muller which sets up a whirling current of water in the vestibule is typical to *Amphioxus*. Vestibule is the only stomodaeal part of the alimentary canal and hence the position of the mouth has become controversial. Some authors consider the enterostome as mouth but it directly opens into the pharynx.

5. **Pharynx:** Extensive growth of the pharynx is helpful in bringing the large quantity of water to the animal and for maintaining a continuous water current which gets sufficient food particles along with it.
6. **Gill slits:** Pharynx has large number of gill slits whose cilia help in maintaining a continuous water current and prevent the escape of food particles.

Gregory has described *Amphioxus* as a specialized and degenerated ostracoderms (Extinct fish like Agnathans with an armour belonging to Ordovician era).

The exact-systematic position of Acrania (Cephalochordata) is still doubtful but detailed study proved the chordate characters to bring them nearer to the Craniata. It may be probable that cephalochordates resemble fish like animals which existed in Silurian period and it is possible that the modern fishes have evolved from similar type of animals.

Check Your Progress

1. Vertebrate affinity of *Amphioxus* is evident in possessing the following highly important characters:
 - (i)
 - (ii)
 - (iii)
2. and are the chief primitive characters of *Amphioxus*
3. Mode of life of *Amphioxus* is depending on these two perfect and highly specialized structures, namely the and

32.7 SUMMARY

1. *Amphioxus* has phylogenetic importance.
2. It has three fundamental chordate characters.
3. It is described as "Fish in Making".
4. It has many primitive characters, e.g. protonephridial system as in flatworms and Annelides.
5. It resembles *Balanoglossus* in respiratory system.
6. It has atrium, endostyle as in *Herdmania*.

32.8 CHECK YOUR PROGRESS — MODEL ANSWERS

1.
 - i) Muscular and Myotomal segmentation.
 - ii) Enterocoel
 - iii) Portal system
2. Notochord, ciliary feeding Noncephalisation and protonephridia.
3. Notochord, oral hood

32.9 MODEL EXAMINATION QUESTIONS

- I. Answer the following in about 30 lines
 1. Discuss the affinities of *Amphioxus*
 2. *Amphioxus* is described as "Fish in making" Discuss.
- II. Answer the following in 10 lines.
 1. Briefly discuss the primitive characters of *Amphioxus*.
 2. Enumerate the specialized characters of *Amphioxus*.

GLOSSARY

Affinities	: Relationship with other animals
Atrio coelomic Canals	: Same as brown funnels
Atrium	: A spacious cavity surrounding the pharynx lined by ectoderm
Branchial sac	: Same as gill pouch
Branchial septum	: Same as gill septum
Branchial tentacles	: Fine branched structures surrounding the base of the siphon
Branchiogenital region	: The region of the trunk which has gill pores and reproductive organs (<i>Balanoglossus</i>)
Brown funnels	: Extensions of atrium into the dorsal coelomic canals at the posterior end of pharynx (<i>Amphioxus</i>)
Buccal cirri	: Long structures present at the ventral end of the oral hood (<i>Amphioxus</i>)
Buccal diverticulum	: Short, hollow and stiff structure present in the roof of the buccal cavity of <i>Balanoglossus</i>
Buccal tube	: Anterior most part of the digestive tract behind mouth.
Coeloblastula	: Early stage of development formed in about 6-15 hrs.
Coelom	: Mesodermal in origin, lined by coelomic epithelium or peritoneum.
Collar	: It is the muscular part of the body of <i>Balanoglossus</i> lying behind the proboscis
Collar cord	: Dorsal nervous strand present in the collar
Dorsal lamina	: Thin flap like fold which hangs down from the middorsal line of branchial sac of <i>Herdmania</i> .
Dorsal sinus	: Pulsatory organ or heart in <i>Balanoglossus</i>
Dorsal tubercle	: Small round sensory structure present in the prepharyngeal zone of <i>Herdmania</i>
Endostyle	: Midventral groove of the pharyngeal wall (<i>Amphioxus</i>).
Enterostome	: An oval aperture present in the centre of velum. It leads into <i>pharynx</i> of <i>Amphioxus</i> .
Epipharyngeal groove	: Middorsal groove of the pharyngeal wall (<i>Amphioxus</i>)
Epipleur	: The ventral flattened space between the oral hood and ventral fin (<i>Amphioxus</i>)
Gastrula	: One of the developmental stages, double layered.
Gill pouches	: Sac like structure of the respiratory system which consists of 'U' shaped gill slit, open to the exterior through gill pore.
Gill sac	: Same as gill pouch
Gill septum	: Front wall of one gill sac joins with the hind wall of the other gill sac forming gill septum
Glomerulus	: Same as proboscis gland
Hatschek's groove	: Glandular groove present in the wall of the vestibule (<i>Amphioxus</i>).
Heart vesicle	: Closed, roughly triangular contractile structure present in <i>Balanoglossus</i> Glomerulus is present on either side of it.
Hepatic caecum	: A club shaped blind pouch like, structure of the midgut called "liver" (<i>Amphioxus</i>)
Hermaphrodite	: Animal which possesses both male and female sexual organs.
Hypopharyngeal groove	: Same as endostyle
Iliocolonic ring	: Heavily ciliated structure present in the posterior part of the midgut of <i>Amphioxus</i>
Intracellular digestion	: Digestion which takes place inside the cell.
Kolliker's pit	: A small olfactory pit present in the anterodorsal surface of <i>Amphioxus</i> .
Languets	: Conical structures present on the free margin of dorsal lamina of <i>Herdmania</i> . These roll up to form a tube through which food passes.
Median eye	: Mass of pigment present in the anterior end of cerebral vesicle.
Mesosome	: Same as collar

Metapleural folds	: Lateral edges of the epipleur
Metasome	: Same as trunk
Muller's organ	: Same as wheel organ
Myocommata	: Connective tissue partition or septum between the myotomes
Myomeres	: Same as myotomes
Myotomes	: Muscle blocks or segments
Nephridium	: Excretory organ with one long vertical limb and one short horizontal limb (<i>Amphioxus</i>)
Neural gland	: Small, oval excretory organ present in the intersiphonal area of <i>Herdmania</i>
Neurocoel	: Cavity of the nerve cord
Notochord	: It is a stiff, elastic long rod like structure with vacuolated cells.
Ocelli	: Cells which act as eyes present on nerve cord
Oesophagus	: Part of the digestive tract lying behind the pharynx
Oral cirri	: Same as buccal cirri
Pharynx	: Part of the alimentary canal lying behind the buccal tube. Its dorsal part acts as respiratory chamber and ventral part functions as alimentary canal
Post hepatic region	: Posterior part of the <i>Balanoglossus</i> which bears anus
Preoral ciliary organ	: 'U' shaped epidermal depression present in the base of the proboscis (<i>Balanoglossus</i>)
Proboscis	: It is the short anterior most part of the <i>Balanoglossus</i>
Proboscis gland	: Blood plexus formed by efferent vessels (<i>Balanoglossus</i>)
Proboscis skeleton	: Flat, plate like structure present in the proboscis (<i>Balanoglossus</i>)
Proprioceptors	: Sense organs responding to internal stimuli
Protogynous	: Ovaries mature first
Protosome	: Same as proboscis
Pygochord	: Hard rod like structure, supports abdominal region of the body (<i>Balanoglossus</i>)
Pyloric gland	: Large branched digestive gland of <i>Herdmania</i>
Retrogressive metamorphosis	: The ascidian larva instead of acquiring advanced chordate characters loses all of them and shows degeneration (Opposite to progressive metamorphosis)
Sexual dimorphism	: Male and female distinguishable from each other
Skeletal rod	: Supporting skeletal structure of primary and secondary gill bars
Solenocyte	: Unicellular structure with a knob present on the caeca of nephridium (<i>Amphioxus</i>)
Stigmata	: Apertures present on the branchial sac through which water goes to the atrium
Stomochord	: Same as buccal diverticulum
Synapticulae	: Short horizontal bars connecting the primary and secondary bars.
Test	: Thick, leathery translucent covering of <i>Herdmania</i> made up of tunicine.
Tongue bar	: Hollow partition separating the limbs of the gill slits.
Tornaria	: Larva of <i>Balanoglossus</i> . It resembles bipinnaria larva of <i>Asterias</i> (Echinoderm)
Trabeculae	: Delicate hollow strands connecting the branchial sac with the body wall (<i>Herdmania</i>)
Trunk	: The part of the body present behind the collar (<i>Balanoglossus</i>)
Tunic	: Same as test
Unisexual	: Having only one sex, either male or female
Velar tentacles	: Sensory structures of the velum
Velum	: A circular sphincter present at the base of vestibule (<i>Amphioxus</i>)
Vestibule	: Space enclosed by the oral hood (<i>Amphioxus</i>)
Wheel organ	: Finger like ciliated ridges present in the wall of the vestibule (<i>Amphioxus</i>)

Suggested Reading

- | | |
|--|--|
| Agarwal, V.P. | A Text Book of Invertebrate Zoology |
| Delela, R.C. | Jai Prakash Nath & Co. Meerut |
| Dhami, P.S. & | Echinodermata - Phylum series |
| Dhami, J.K. | R Chand & Co. Publishers, New Delhi |
| Dhami, P.S. & | Vertebrate Zoology |
| Dhami, J.K. | R. Chand & Co. Publishers, New Delhi |
| Jordan and Vishnoi | Chordate Zoology |
| Jordan, E.L. & | Invertebrate Zoology |
| Varma, P.S. | S. Chand & Co. |
| Kotpal, R.L. | Echinodermata - Zoology phylum series Rastogi Publications Meerut |
| Kotpal, R.L. Agarwal
V.P. and Khetrapal | Invertebrate Zoology,
Rastogi Publications, Meerut |
| Majhpurja | A Text Book of Invertebrate Zoology |
| Parker & Haswell | Text Book of Zoology Invertebrates (Edited by A.J. Marshall & W.D.
Williams) Mc Millian Company |
| Prasad, S.N. | Text Book of Invertebrate Zoology, Kitab Mahal Publications,
Allahabad. |

BRAOU

BRAOU

Dr. B.R. Ambedkar Open University

(Under-graduate Programme)

B.Sc., Second Year Syllabus

Zoology : Course - 1

Paper - I NON-CHORDATA & PROTOCHORDATA

- : **General introduction on Animal Kingdom.**
- : Principles of Animal Taxonomy and Systematics,
- : **Sub Kingdom Protozoa**
- : Classification upto classes and their general characters with examples.
- : Study of Morphology and Life Cycles of 1. *Elphidium*, 2. *Monocystis*, 3. *Vorticella*.
- : Protozoan diseases of human importance, their life cycles pathogenicity and control methods. (1. Malaria, 2. Amoebiasis, 3. Kalaazar)
- : **Phylum Porifera**
- : General Characters, Classification upto classes with examples. Study of *Sycon* as the type.
- : **Phylum Cnidaria**
- : General Characters and Classification upto classes with examples. Study of *Obelia* as the type.
- : **Phylum Platyhelminthes**
- : General Characters and Classification upto classes with examples.
- : Important trematode and cestode parasites e.g. *Fasciola hepatica*, *Schistosoma hematobium*, *Taenia solium*, *Echinococcus granulosus*. a brief sketch on their life cycles, pathogenicity and control methods.
- : **Phylum Aschelminthes**
- : General Characters and Classification upto classes with examples.
- : Important nematode parasites. e.g. *Ascaris lumbricoides*, *Ancylostoma duodenale*, *Wuchereria bancrofti*, *Dracunculus medinensis*. a brief sketch on their life cycles, pathogenicity and control methods.
- : **Phylum Annelida**
- : General Characters and Classification upto classes with examples
- : Study of *Nereis*
- : **Phylum Mollusca**
- : General Characters and Classification upto classes with examples.

- : *Pila* as the type study.
- : Economic importance of Mollusca with special emphasis on oyster culture and pearl formation.
- : **Phylum Arthropoda**
- : General characters and Classification upto classes (with examples)
- : Study of *Palaemon*.
- : General Characters and Affinities of Onychophora (*Peripatus*).
- : Edible Crustaceans & Prawn Culture.
- : Beneficial insects (a brief note on apiculture, sericulture and Lac culture).
- : Harmful insects (a general survey).
- : **Phylum Echinodermata**
- : General Characters and Classification upto classes with examples.
- : Study of *Asterias* (Morphology and Anatomy)
- : Echinoderm larvae (A brief introduction of *asterias* development upto larval stages should be given.
- : Evolutionary trends in Invertebrates.
- : Evolutionary trends in invertebrates (Concepts of coelom, radial & bilateral symmetry, cephalization, metamerism etc. & their role in evolution).
- : **Protochordates** (with a general introduction on the characters of chordates)
- : Sub phylum Hemichordata, general characters and classification.
- : *Balanoglossus* a type study.
- : Affinities of hemichordates.
- : Sub phylum Urochordata, general characters and classification.
- : *Herdmania* and affinities Urochordates.
- : Development of *Herdmania* and affinities Urochordates.
- : Sub Phylum Cephalochordata, *Amphioxus*.
- : Affinities of *Amphioxus*.

FACULTY OF SCIENCES
SECOND YEAR (3 YEAR DEGREE COURSE) EXAMINATION
MODEL QUESTION PAPER

ZOOLOGY

COURSE-1: NON-CHORDATA AND PROTOCHORDATA

Time: 3 Hours.

Max. Marks: 75

Section - A

Answer any 3 questions

Each question carries 15 marks

Answer the following in about 30 lines each.

1. Describe briefly the life cycle of Plasmodium.
2. Mention the differences between polyp and medusa of oblia.
3. Describe the life history of Schistosoma hematobium. Add a note on its pathogenecity.
4. Write an essay on harmful insects.
5. Give a brief account of larvae found in Echinodermata. What is their evolutionary importance.
6. Discuss the digestive system and physiology of digestion of sea squirt (Herdmania).

P.T.O.

Section-B

Answer any 5 questions

Each question carries 6 marks

Answer the following in about 10 lines each

1. Alternation of generations in Elphidium.
2. Write a note on Kalaazar.
3. Asexual reproduction in Sycon.
4. Pathogenicity and controlling measures of echinococcus granulosus.
5. Nereis parapodium.
6. Describe the structure of a gill in prawn.
7. What is lac? How is it formed? Add a note on lac cultivation.
8. Tomaria larva.
9. Pharynx of Herdmania.
10. Specialized characters of Amphioxus.

DR. B.R. AMBEDKAR OPEN UNIVERSITY
UNDERGRADUATE COURSES-SECOND YEAR
ZOOLOGY
COURSE-1 : NON-CHORDATA & PROTOCHORDATA
ASSIGNMENT - 1

N.B.

1. Do not copy the answer directly from any of the books.
2. As far as possible try to answer the questions independently in your own words.
3. If it is necessary to quote from any source give the correct reference.
4. Use your own foolscap pages for writing the assignment.
5. Leave sufficient margins for the comments of the evaluator.
6. Completion of this assignment should not take more than two hours time.

I. Answer the following questions in about 30 lines

1. Describe briefly the life cycle of Plasmodium.
2. Explain the canal system of sycon and enumerate its advantage.
3. Describe the life history of Schistosoma hematobium. Add a note on its pathogenesis.

II. Answer the following questions in about 10 lines.

1. Anti malarial schemes
2. Write a note on Kalaazar
3. Describe the structure of Medusa.

BRAOU

DR. B.R. AMBEDKAR OPEN UNIVERSITY
UNDERGRADUATE COURSES-SECOND YEAR

ZOOLOGY

COURSE-1 : NON-CHORDATA & PROTOCHORDATA

ASSIGNMENT - 2

N.B.

1. Do not copy the answer directly from any of the books.
2. As far as possible try to answer the questions independently in your own words.
3. If it is necessary to quote from any source give the correct reference.
4. Use your own foolscap pages for writing the assignment.
5. Leave sufficient margins for the comments of the evaluator.
6. Completion of this assignment should not take more than two hours time.

I. Answer the following questions in about 30 lines

1. Describe briefly the life cycle of *Wuchereria bancrofti* and add a note on its pathogenecity.
2. Discribe the Digestive system of *Pila*. Add a note on the physiology of digestion.
3. Give a brief account of larvae found in Echinodermata. What is their evolutionary importance.

II. Answer the following questions in about 10 lines.

1. Describe the general characters of the class Polychaets along with few examples.
2. Describe the tochophore larva with the help of neat labelled diagram.
3. Describe the distinguishing characters of onychophora.

BRAOU

DR. B.R. AMBEDKAR OPEN UNIVERSITY
UNDERGRADUATE COURSES-SECOND YEAR

ZOOLOGY

COURSE-1 : NON-CHORDATA & PROTOCHORDATA

ASSIGNMENT - 3

N.B.

1. Do not copy the answer directly from any of the books.
2. As far as possible try to answer the questions independently in your own words.
3. If it is necessary to quote from any source give the correct reference.
4. Use your own foolscap pages for writing the assignment.
5. Leave sufficient margins for the comments of the evaluator.
6. Completion of this assignment should not take more than two hours time.

I. Answer the following questions in about 30 lines

1. Discuss the affinities of Hemichordata with Chordates.
2. Define retrogressive metamorphosis.
3. Give an account of external features of Amphioxus.

II. Answer the following questions in about 10 lines.

1. Haemal system of Asterias.
2. Tadpole of Herdmania.
3. Enteropneusta

BRAOU