



BS3\_Z3

# Zoology

## ECOLOGY AND PHYSIOLOGY

BLOCKS : 5 & 6

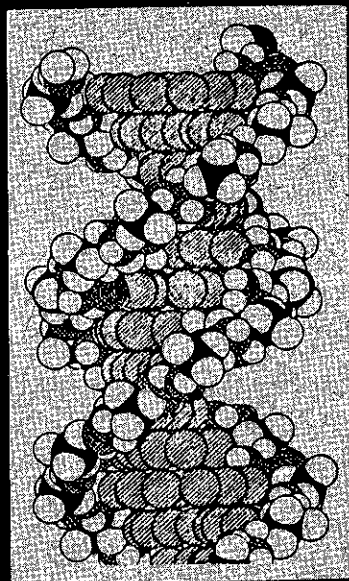
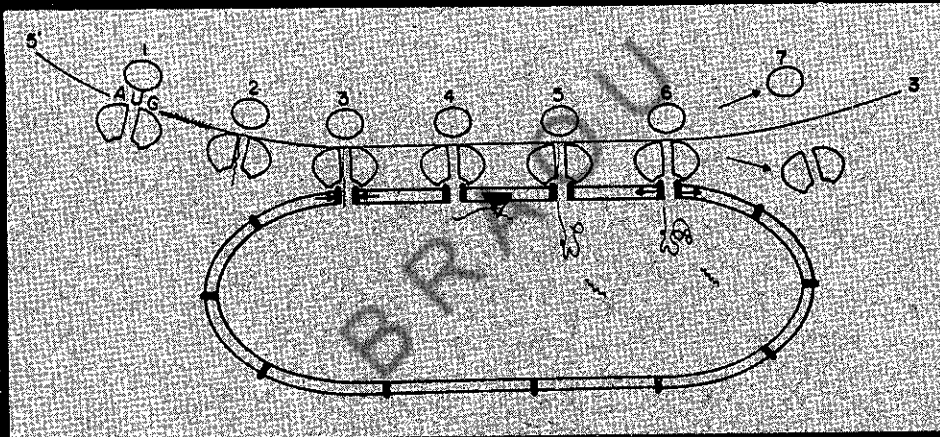

BRAOU

# ZOOLOGY

## ECOLOGY, PHYSIOLOGY

### BLOCKS 5 – 6

BLOCK V  
BLOCK VI

ECOLOGY  
PHYSIOLOGY

BRAOU

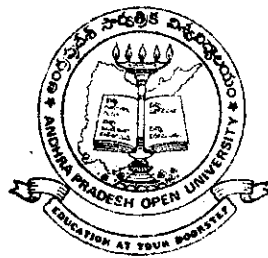

ANDHRA PRADESH OPEN UNIVERSITY  
HYDERABAD  
1991

## COURSE TEAM

### Editor

Prof P. Ramachander Rao

### Associate Editor

Dr (Mrs) Girija Neti

### Writers

Sri J. Konete Rao

Dr K. Baktavatsal Rao

Sri P. Kailasapathi

Dr V. Chandrasekharam

Dr S. Vijaya Lakshmi

Sri G. Manohar Reddy

Dr K. R. Purushotham

Dr M. A. Uday Kumar

### Cover Design

M. Ramesh

### Graphics

M. Ramesh

BRAOU

Andhra Pradesh Open University  
Hyderabad - 500 482

First Published 1985.

Copyright © 1985 A.P. Open University

Second Published - 1991.

All rights reserved. No part of this book may be produced in any form without permission in writing from the University.

This text forms part of an Open University Course. The complete syllabus for the course appears at the end of this text.

Further information on Open University Courses may be obtained from the Director, (Academic), A.P. Open University, 6-3-645, Somajiguda, Hyderabad - 500 482 (A.P.)

Phototypesetting at Shri Gopala Kwik Graphics & Printed at Shri Gopala Kwik Graphics, Hyderabad - 16.

## PREFACE

This book deals with the topics in Cytology, Genetics, Evolution, Zoogeography, Ecology and Animal Physiology included in the syllabus for the third year of the Zoology course offered by the Andhra Pradesh Open University. These topics generally cover the "Core" area of the subject to be studied in the third year of the three year degree course in Science (B.Sc.). The syllabus for the sake of convenience is divided into several Blocks each of which comprise a number of units. Each Block generally covers a specific area of the subject. The units are prepared by specialists in accordance with the format so designed as to enable the student to read and understand them without much difficulty. Each unit brings with a statement of its objectives followed by synopsis and has at its end assignments intended to test the students comprehension of its subject matter. Technical terms with which the student may not generally be familiar are given at the end of each unit under the head "Glossary".

The course material of this paper is divided into Six Blocks. The Blocks are in turn divided into thirty six units. Block-I deals with the important topics in Cytology. The topics in Genetics are included under Block-II.

Important topics like human syndromes, inborn errors of metabolism and operon concept are also included under this Block.

Block – III deals with the general topics on evolution like theories, evidences, synthetic theory etc. Unit – 19, evolution of man and horse is given. Principles of Zoogeography is, given in Block-IV.

Block – V deals with Ecology. Besides general chapters, important topics like pollution and wild life conservation are included under Ecology.

The last Block is devoted for the topics on Animal Physiology. Special topics like Nutrition, Neurotransmitters, Biological rhythms and Immunological responses are given under the Seventh Block.

The University hopes that this material will help the students to get acquainted with the topics on Cytology, Genetics, Evolution, Zoogeography, Ecology and Animal Physiology.

BRAOU

## CONTENTS

### Block - V Ecology

Unit - 21	Introduction to Ecology – Fundamental Concepts of Ecosystem, Food Chains, Energy Flow, Trophic Levels	1
Unit - 22	Ecological Factors	7
Unit - 23	Community Structure and Ecological Succession	14
Unit - 24	Population Ecology	20
Unit - 25	Environmental Pollution – Radiation Hazards	27
Unit - 26	Wild Life Management	36
Unit - 27	Carbohydrates, Proteins and Fats – Biological Oxidation	49
Unit - 28	Vitamins and Minerals	56
Unit - 29	Osmo Regulation	67
Unit - 30	Respiration	77
Unit - 31	Circulatory System	86
Unit - 32	Nervous System	96
Unit - 33	Muscle Contraction	103
Unit - 34	Reproduction	112
Unit - 35	Biological Rhythms	117
Unit - 36	Immunological Responses	122

BRAOU

---

**BLOCK – V**  
**ECOLOGY**

---

BRADU

BRAOU

---

# UNIT - 21 INTRODUCTION TO ECOLOGY - FUNDAMENTAL CONCEPTS OF ECOSYSTEM, FOOD CHAINS, ENERGY FLOW, TROPHIC LEVELS

---

## Contents

- 21.1 Objectives
- 21.2 Introduction
- 21.3 Ecosystem
  - 21.3.1 The Pond-Eco System
- 21.4 Energy Flow in Ecosystems
- 21.5 Summary
- 21.6 Check Your Progress - Model Answers
- 21.7 Model Examination Questions

---

## 21.1 OBJECTIVES

---

To explain the meaning of ecology, concepts of ecosystem and energy flow within the ecosystem. At the end of this unit you will be able to explain

- the components of Ecosystems
- energy flow in Ecosystems etc.

---

## 21.2 INTRODUCTION

---

The word 'ecology' is derived from the Greek word, *oikos* meaning house or habitation and 'logos' meaning study. Thus literally it means 'at home'. The study of living organisms, their environment (both physical and biotic components) including the inter species interactions constitute ecology.

The study of ecology of a an individual is called **autecology** and the study of the groups belonging to a same species is called **Population ecology**. The **aquatic ecology** includes freshwater, estuarine and marine; **terrestrial ecology** includes forest, grassland, cropland and desert.

Since man is influenced by environment like other organisms, the study of general principles of ecology provides the background for understanding the human relation. By applying certain ecological principles, forestry, agriculture, horticulture, pest control, aquaculture, etc, be thoroughly developed. Knowledge of ecology is essential to the solving of certain problems like erosion, disposal of wastes, control of chemical and radioactive fallout, pollution of environment, etc..

---

## 21.3 ECOSYSTEM

---

Ecosystem can be said to be the functional unit in ecology. It includes the study of living organisms and the nonliving environment, each influencing the other, and both are necessary for the maintenance of life.

The term, ecosystem, was first coined by A.G.Tansley in 1935. Karl Mobius considered the community of oyster reef to be biocoenosis in 1877.

From the trophic (nourishment) point of view ecosystem has two components, namely, an autotrophic component in which the light energy is fixed through photosynthesis and a heterotrophic component in which the rearrangement, utilization and decomposition of complex molecules occur. From the structural point of view the ecosystem has four basic units.

- 1) **Abiotic substances:** They include the inorganic and organic compounds of the environment. Carbon, nitrogen carbondioxide, water, hydrogen and phosphates which are involved in nutrient cycles form the inorganic compounds. proteins, carbohydrates, lipids, amino acids form the organic compounds. In addition, temperature, light, humidity and other climatic factors are also included.
- 2) **Biotic substances:** They include the producers, consumers and decomposers.
  - i) **Producers:** These are autotrophs, mostly green plants which manufacture the complex organic substances (carbohydrates) from simple inorganic substances.
  - ii) **Macroconsumers:** These are heterotrophs, mostly animals, which feed on other organisms or the organic material. They can be primary consumers (herbivores) that feed on the primary consumers.
  - iii) **Microconsumers:** These are heterotrophs, mostly bacteria and fungi, also called saprotrophs of decomposers. They break down the complex composition.

Thus one of the important features of ecosystems is the interaction of autotrophic and heterotrophic components. The organisms involved in these processes are stratified one above the other, the autotrophic metabolism occurring in the brown belt. This type of separation leads to possible classification of energy circuits into i) grazing circuit - direct consumption of living parts ii) organic detritus circuit-accumulation and decomposition of dead material.

### 21.3.1 The pond ecosystem

A pond or a lake constitutes the best example of an ecosystem (Fig 21.1)

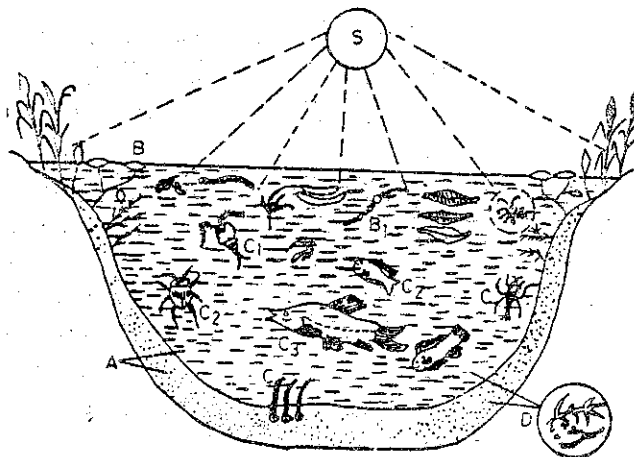

Fig 21.1 Four basic Units of Ecosystem A: abiotic substance, B: Producers - rooted and floating plants B<sub>1</sub> producers Phytoplankton; C: Primary consumer (herbivores) bottom forms: C<sub>1</sub> Primary Consumers (herbivores)-Zooplankton; C<sub>2</sub> Secondary consumers (Carnivores) C: tertiary Consumers (Secondary carnivores) D: decomposers- bacteria & fungi.

The abiotic substances of a freshwater pond are water, dissolved oxygen, carbon dioxide, inorganic salts like phosphates, nitrites, chlorides of sodium, potassium, calcium, etc., and a group of organic compounds like amino acids, humic acids, etc.

Lakes and ponds are vertically stratified in relation to the intensity of wavelength, absorption, pressure, temperature etc. They are as follows:

1. **Littoral zone:** It is the shallow water region into which the light can penetrate. The upper layers are oxygen rich and warm called epilimnion.

a) **Producers:** Rooted plants and phytoplankton. Rooted plants with floating leaves: eg, Waterlilies (*Nymphaea*), *Nelumbo*, *Trapa*, *Potamogeton*, etc.

Rooted plants with submerged leaves: Mostly pond weeds e.g. *Vallisneria*, *Elodea* and *Myriophyllum*, *Ceratophyllum*, *Hydrilla*, *Chara*, *Nitella*, *Spirogyra*, *Zygnema*, *Oscillatoria*, *Rivularia*, etc. In addition, there are some protozoans like *Euglena*, *Verticella*, *Stenter*, etc.,

b) **Consumers:** In the peripheral regions, snail, midge larvae are the primary consumers. Dragon fly, Damselfly larvae are the secondary consumers (carnivores). But in the benthic region, a number of consumers exist. For example, Crayfish, Isopod, Clams, Worms, and free swimming fauna (Nekton) constitute the *Paramaecium*. larvae of *Culex*, *Gerris*, etc. beetles, water snakes, fish like sunfish, salamanders, turtles, Zooplankton offers a typical example with the *Cladocerans*, water flies *Daphnia*, *Simocephalus*, *Copepods* and *Ostracods*, *Rotifers* etc.,

The floating members (Neuston) of the littoral zone consist of surface insects like beetles and water striders.

Decomposers protozoans, nematodes, copepods, etc

## 2. **Limnetic zone**

It extends upto 10 meters from water surface. This is also called **sublittoral zone**. The communities in this include plankton, nekton, and a few neuston. The term euphotic zone refers to both littoral and limnetic zones.

a) **Producers :** Phytoplankton includes the members of *Chlorophyceae*, *Cyanophyceae* : algae like dinoflagellates. *Euglena* and *Volvox*. Usually, they appear as pond blooms in early spring and in the later part of autumn.

b) **Consumers :** The primary consumers are copepods, Cladocerans, Rotifers, Cyclops is the most abundant form. Many crustaceans are plankton feeders and some are predators. Blooms of zooplankton appear immediately after the phytoplankton. The nekton (secondary consumers) are mostly fish.

## **Profundal Zone**

It is characterised by the absence of light and hence they depend on the members of limnetic and littoral zones for food. In return, the profundal zone provides nutrients which are carried out by currents and swimming animals to other zones, producers and consumers are lacking in this zone. The saprophytes or decomposers constitute the communities. Bacteria and fungi are abundant. The animal consumers are benthic-chironomid larvae, annelids, clams, planktonic forms-plankton larvae. Most of the bacteria act as decomposers, while a few are pathogenic.

Ponds show a clear stratification having an upper production zone and a lower decomposing or nutrient generating zone. In the upper most layers (the first two meters), photosynthesis exceeds respiration. In the bottom layers of water where the light intensity is less only respiration occurs.

## 21.4 ENERGY FLOW IN ECOSYSTEMS

Energy may be defined as the capacity to do work. The changes energy in ecosystems involving transmission and utilisation at different trophic levels constitute the energy flow circuits.

There are two kinds of energy: potential and kinetic. While the Potential energy is the energy at rest. Kinetic energy is due to motion and results in work.

The utilization of energy is described by two laws of Thermodynamics. The first is called **law of conservation of energy** which states that energy is neither created nor destroyed. This means that energy is simply transformed from one place to another or from one form to another.

The second law states that spontaneous transformation of energy into potential energy is not 100% efficient. For example, when an animal takes in potential energy as food, it gets converted into heat. At every step, while transferring energy from one organism to another, a large part of it is reduced to heat.

The transfer of food energy from plants (source) through repeated eating and being eaten is referred to as **food chain**. The shorter the food chain, the greater is the energy available.

A simple food chain may have 3 or 4 links:

**Aquatic ecosystem:**

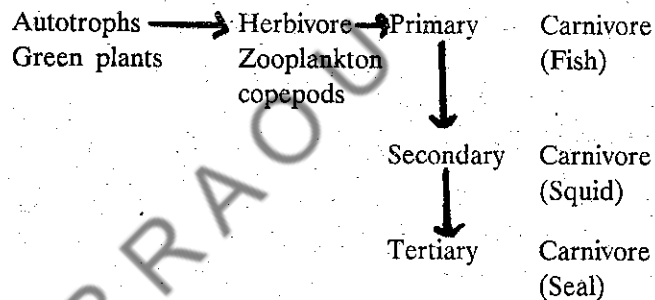

**Terrestrial ecosystem:**

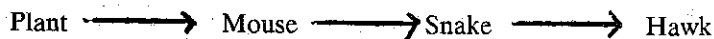

These carnivores are linked with several food chains. Thus the food chains are interconnected with one another. This interchange of various food chains is called **food web**.

Basically two types of food chains are in existence:

(1) grazing food chains and (2) detritus food chain.

### 1) Grazing food chain

It starts from green plants and ends with the carnivore by passing through the herbivore.

Autotrophy  $\longrightarrow$  Herbivore  $\longrightarrow$  Primary carnivore  $\longrightarrow$  Secondary carnivore

This chain is called predator chain. Similarly parasitic chains also exist where small organisms consume large ones without killing them completely.

### 2) Detritus food chain

The transfer of energy from dead organic matter into microorganisms and then into their predators is termed detritus food chain.

In the detritus food chain, energy flow occurs continuously rather than as a stepwise flow. In the grazing food chain energy storage is in the tissues of living beings, but in detritus food chain the energy may be stored outside the organisms.

These organisms ingest the organic matter and excrete the remainder as simple organic molecules. The waste thus excreted from one organism may be immediately utilised by a second organism and the process repeated. Sometimes instead of the breakdown of complex substances into simple ones the original wastes may be converted directly into CO<sub>2</sub> and water. In the majority of instances the organic matter is converted to humic acids or humus.

As we pass from one step to another in the grazing food chain, the number and mass of organisms get limited by the amount of energy available. Since some energy is lost as heat in each transformation, the step becomes progressively smaller. The producer level forms the base and the successive levels make the apex and thus the figure assumes the shape of a pyramid and this is called the 'ecological pyramid'.

The ecological pyramids may be of 3 types:

### 1. Pyramid of numbers

It illustrates the population density, relationships within and among the trophic levels. The number of animals at the base are more than at higher levels and decreases at each trophic level due to reduced growth rate and predation.

The pyramid of numbers ignores the biomass and does not indicate the energy transformed. e.g., pond or lake ecosystem. The lowest trophic level is occupied by diatoms, which are abundant. The second trophic level is occupied by copepods, the third and fourth are occupied by smaller and larger fish. There is considerable reduction in the number of animals from the base to the tip of the pyramid.

### 2. Pyramid of Biomass

Biomass is defined as the total weight of dry matter present in the ecosystem at any given time. This type of pyramid shows decrease in biomass from lower to higher trophic levels. In terrestrial ecosystem, the tip are autotrophs, herbivores, primary, secondary and tertiary carnivores, etc.,

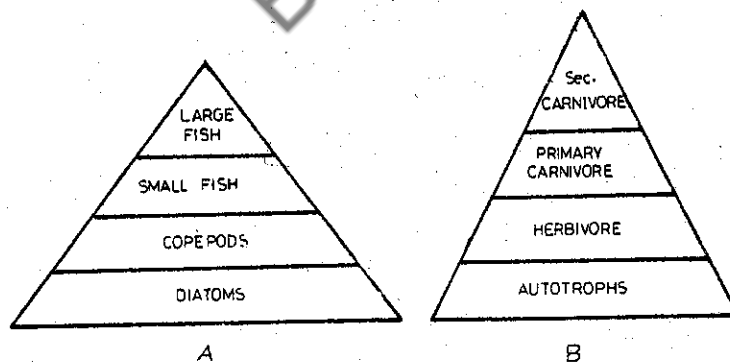

Fig. 21.2 Ecological Pyramid A - The upright Pyramid of numbers in a pond B - The upright Pyramid of numbers in crop field

### 3. Pyramid of energy

It indicates the amount of energy flow at each trophic level in the ecosystem as well as the role played by different organisms in the transfer of energy. Greater amount of energy is available at producer level than at the primary consumer level. So the amount of energy decreases from the base to the apex of the pyramid.

### Check Your Progress

1. The transfer of energy from dead organic matter into microorganisms and then into their predators is termed \_\_\_\_\_.
2. The carnivores are linked with several food chains. Thus the food chains are interconnected with one another. The interchange of various food chains is called \_\_\_\_\_.

---

### 21.5 SUMMARY

---

1. Ecology is the study of organisms and their environment. Ecological principles help in human advancement. Ecosystem is the basic functional unit in ecology. In the ecosystem nutrients are cycled through biotic and abiotic components.
2. Abiotic substances include organic and inorganic compounds.
3. Biotic substances include the producers, consumers and decomposers. These are called trophic levels.
4. Energy within the ecosystem flows through circuits. The transfer of energy within the components of ecosystem is called food chain.
5. The ecological pyramids represent the relationship of populations within and among the trophic levels.

---

### 21.6 CHECK YOUR PROGRESS - MODEL ANSWERS

---

1. Detritus food chain
2. 'Food Web'.

---

### 21.7 MODEL EXAMINATION QUESTIONS

---

- I. Answer the following in about 30 lines each:
1. Describe the functional aspect of ecosystem.
  2. Define ecosystem and describe the components of pond ecosystem.
  3. What is ecology? Explain its significance.
  4. Describe different kinds of ecological pyramids.
  5. What is food chain? Describe different types of food chains.

---

# UNIT - 22 ECOLOGICAL FACTORS

---

## Contents

- 22.1 Objectives
- 22.2 Introduction
- 22.3 Temperature
- 22.4 Light
- 22.5 Water
- 22.6 Summary
- 22.7 Check Your Progress - Model Answers
- 22.8 Model Examination Question

---

## 22.1 OBJECTIVES

---

This Unit deals with three important abiotic factors - temperature, light and water. At the end of this unit you will be able to explain:-

- temperature tolerance in animals,
- mechanisms regulating the body temperature,
- effect of temperature on animals and adaptations to overcome cold and heat,
- similarly you will be able to explain in detail, the other two parameters of ecological importance.

---

## 22.2 INTRODUCTION

---

The environment is a complex of several factors. Charles Darwin first described the influence of abiotic and biotic factors on the organisms.

The abiotic factors can be classified into two classes, namely, physical factors (temperature, light, water, wind, etc. and chemical factors (pH, nutrients, etc.).

---

## 22.3 TEMPERATURE

---

It is one of the most important and essential ecological factors. It acts as a limiting factor for growth and distribution of organisms.

Various species shift between homeothermy and poikilothermy and these are known as heterotherms: e.g., pigmy mouse which aestivates or hibernates according to changes in temperature. Humming bird become nocturnal in hot weather.

### Effect of temperature on animals

1. **Metabolism:** Most of the metabolic activities in animals are regulated by enzymes which in turn are influenced by temperature. Increasing in temperature up to certain limit increases the enzyme activity thereby increase the metabolic rate. Most of the enzymes show increase in enzyme activity from 17°C to 48°C and later on show retardation.

An increase in temperature by 10°C causes two to three-fold increase in the rate of a biological process. This is called "Vant Hoff's law."

2. **Development:** In general the eggs and larvae of terrestrial species require a higher temperature than adults.
3. **Growth:** Adult trouts do not grow until the water is warmer than 10°C. The length of oyster increase from 1.4 mm to 10.3 mm when the temperature increases from 10° C to 20° C.
4. **Morphology:** a) In warm humid climates many insects, birds and mammals have darker pigmentation than when living in cool and dry climates. This phenomenon is called 'Glober rule'. (b) Temperature can effect the relative size of certain parts of the body. Birds and mammals living in colder regions attain greater body size than those living in warmer regions. This is called 'Bergmann's rule'.

The extremities like tail, ears and legs of mammals become shorter in cold climates. This is called 'Allen's rule' e.g. Mice reared at 31°C have longer tails than those of the same strain reared at 15°C. Temperature is known to influence the number of vertebrae in certain species of fish, which obey the 'Jordon's rule' e.g., the fish living in 4-8°C have 56 vertebrae while the same species living in temperature of 10-11°C possess 54 vertebrae.

The relationship between seasonal changes in temperature and the body form may be explained by a remarkable phenomenon called 'Cyclomorphosis'. It is best exhibited by certain cladocerans. e.g., *Daphnia*. These crustaceans show striking differences in the size of the helmets or the head projections between winter and summer months (Coker, 1931). In winter the head is round in shape. During spring a helmet like projection develops and attains it's maximum size in summer. During autumn it gets reduced and disappears altogether in winter to resume the usual shape of a round head (Fig. 22.1) Such a kind of cyclomorphosis shows a clear relationship between the temperature and the morphological changes. Two hypotheses were put forward to explain this cyclomorphosis.

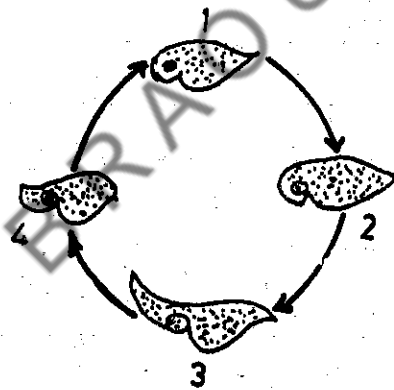

Fig. 22.1 Cyclomorphosis in *Daphnia* 1. Winter 2. Spring 3. Summer 4. Autumn.

1. **Buoyancy hypothesis:** As the temperature of water rises during summer, the buoyancy of water becomes reduced. Therefore, to aid the floatation process in summer, certain adaptations like projections of the head occur.
2. **Stability hypothesis:** According to this, the helmet acts like a rudder and gives greater stability to the animal.

#### Adaptations to temperature

Animals become dormant to overcome the effects of temperature.

The term. 'hibernation' is used to describe the situations in which metabolism is reduced during winter. Many poikilotherms hibernate in cracks and crevices or in mud. In homeotherms, during hibernation, body temperature, metabolism, respiration, heart beat are reduced. For this slow activity the animal derives energy from organic reserves like glycogen. Hedgehogs,

bats and rodents are some of the mammals which undergo hibernation . Hibernation consists of low temperature of the body (hypo-thermia) accompanied by sleep. Hibernation is first induced by cold environment and later regulated by internal hormones.

Aestivation refers to the reduced activity or dormancy during summer to avoid excess heat in summer. It is seen only in some invertebrates and in certain mammals: e.g., Heteropteran bugs, the snail, Ariophanta. Many insects undergo diapause, a condition during which the morphological growth and development of animal are suspended or retarded.

In animals thermal migrations do occur. the journeys under taken by animals that enable them to escape from extremely hot or cold situations are called 'thermal migrations'. e.g: round squirrels do not move out of their burrows to avoid the severity of temperature in winter or in summer. Frogs turtles and amphibians make short trips into or out of water for cooling or warming. Many fishes and aquatic animals leave the shore in summer; others migrate into deep water during winter to avoid low temperatures. Insects migrate from north to south. Migration is well exhibited by birds. In their cases in addition to temperature, other factors like food, breeding climate, etc., are responsible.

## 22.4 LIGHT

Light is a form of radiant energy from sun. The radiant energy is trapped and utilized by green plants through photosynthesis. Unlike temperature, light is a non-lethal factor and has a specific direction in its flow.

In addition to visible light, sun emits other radiations of different wave lengths-cosmic rays, gamma rays, X-rays, UV rays, infra red, radio waves, electromagnetic waves. Of bulk of solar radiation, visible light forms only a narrow region of electromagnetic spectrum (Fig. 22.2).

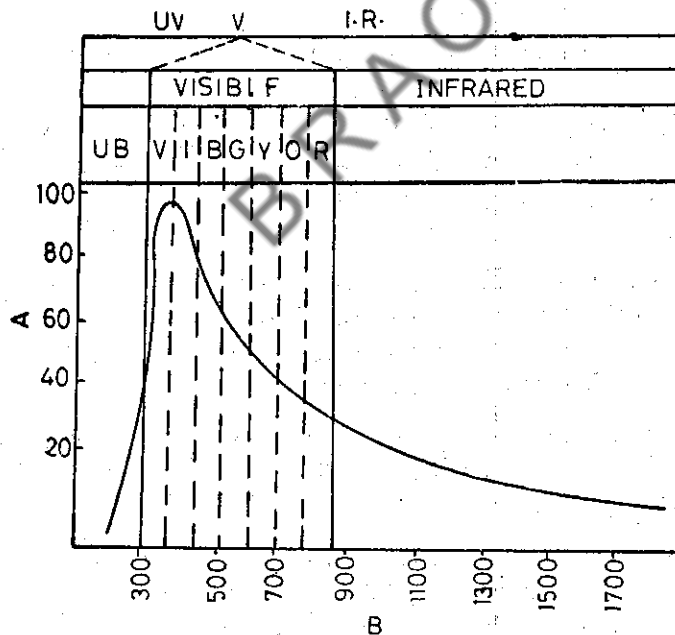

Fig. 22.2 Electromagnetic Spectrum of light.

About 10% of the light reaching water is reflected back and only 20% penetrates into the water. The longer rays are absorbed by surface water while the shortest rays penetrate deep. Depending on the penetration of light, oceans are divided into euphotic zone (upto 50 meters depth), disphotic zone (between 80-200 meters) and aphotic zone (below 200 meters). In

oceans algae are distributed according to the depth of light rays; green algae lie in intertidal zone: brown algae in somewhat deeper layers and red algae in deep oceanic waters of which they are a characteristic feature.

### Effects of light on organisms

**Metabolism:** The light absorbed by the animal results in ionization of protoplasm and thereby increases the enzyme activity and the general metabolic rate. Cave animals show a less metabolic rate than others. The best example of the photochemical reaction is the photosynthetic process occurring in plants.

**Pigmentation:** The pigmentation of skin is associated with light. The pigments seen in chromatophores are directly controlled by the intensity of light. Certain aquatic animals lose their colour when removed from light. Cave dwelling amphibians and fishes have little or no colour but when exposed to light, they tend to develop pigmentation on their bodies.

Animals protect themselves from enemies by pigmentation. This is called protective colouration. Some reptiles, amphibians, fish, crustaceans, insects are able to change their colour in order to match their surroundings.

**Orientation:** Oriented locomotory movements towards and away from source of light is called 'phototaxis'. The movement of an organism towards the source of light is said to be photopositive or positively phototactic. *Euglena* and *Ranatra* move towards the source of light while *planaria*, earthworm, copepods, siphonophores, etc., move away from the source of light i.e., negatively phototactic. When only one part of an organism shows movement positive to the light source, it is called Phototropism flagellum in *Euglena* and polyp of coelenterates move towards light.

The movement of animals at a constant angle towards the source of light is called light compass reaction or celestial orientation. Such orientation has been observed in fishes, turtles, lizards, birds, etc.

**Photoperiodism:** The photoperiod is measured in terms of the length of the day. Regular cyclical operation of light (day) and dark (night) are known to influence behavior and metabolism of animals. These responses of different organisms to the rhythmical occurrence of light and dark is called 'photoperiodism'. Similar to diurnal periodicity there exists seasonal, lunar periodicity, etc. Most of the mammals are diurnal and only a few like bats and rodents nocturnal.

The rhythmicities are exogenous and endogenous. Organisms respond to exogenous factors like light, intensity, humidity, temperature, tides, etc. The endogenous rhythmicities are innate and little affected by temperature and chemical inhibitors. The Physiological properties of animals like appetite, sleep, awakesness, etc., are also under the influence of diurnal rhythms.

**Development and Growth:** Light in some cases accelerates the development for example, Salmon larvae do not develop in the absence of light. In some cases absence of light enhances the development e.g., *mytilus* larvae.

With increase in depth, the size of the eyes increases in organism upto the upper limit of lightless zone, below which the eyes are smaller; and eyes are completely degenerated in bottom dwellers. Many fishes have large telescopic eyes, some crustaceans at 800 m depth are able to see the objects with the adjustment of rods and cones the pigments in the retina of the eye. In terrestrial nocturnal animals like owls and geckos, there are large protruding eyes.

Due to the lightlessness animals may become carnivores. They have large mouths, teeth and elastic stomach and abdominal walls.



body fluids, i.e., hypotonic. Depending on the tolerance of salinity, animals are classified as euryhaline or stenohaline.

Organisms living in pond, on lake develop a variety of methods or adaptations to cope with the drying or fouling of water. Some invertebrates like protozoans, sponges, and crustaceans, develop resistant spores. *Daphnia* reproduces rapidly before the water gets dried. Some fishes undergo such physiological changes as would enable them to live in grass or mud: from example, *Protopterus* can live in mud, and cocoon in drought. It secretes a substance around the body which prevents water loss from the body. Amphibians live in burrows and go through their dormancy phase.

### Terrestrial environment

The water problem in terrestrial environment is acute. Animals adapt themselves to various devices so as to minimise the loss of water. Animals get water by drinking, by absorbing through skin, from their food, and from the water produced by metabolism. The following adaptive features may be seen.

1. **Impervious skin:** Animals living in dry areas (like deserts) have thick impermeable body covering. Such integument is seen in insects, birds and mammals. Ruminants and rodents do not have the sweat glands. *Phrynosoma* exhibits a spiny skin. Desert dwellers show in digging mechanism. Certain amphibians, and earthworms restrict themselves to swamps, moist soil or similar damp places.
2. **Internal lungs or tracheal system:** The mode of respiration has some relations to water. Gills in crustaceans are provided with a water retaining carapace. It serves as a liquid environment for the gills. The scales on the fish are impermeable to water or exchange of gases, which are limited to gills. The internal lungs in snails, spiders, amphibians, reptiles, birds and mammals and the tracheal system in insects have the capacity to save water.
3. **Selective food:** Most of the herbivores depends on the food having a large amount of water. For example, for goat, and the carnivores get the water from the blood of their prey. Insects feed on those parts of the plants which have a high water content. Most of the animals make use of the water released through the oxidation of fats, and carbohydrates. The camel in the desert can live for 11 days without drinking water as the water obtained from the oxidation of fat in its hump and the water in special compartments of stomach its water requirement.
4. **Dry excretion:** Water saving insects, reptiles and birds excrete the dry nitrogenous wastes as solid uric acid.
5. **Suspended animation:** Animals with simple organization like rotifers, nematodes, snail, etc., retain their vitality in dry environment. Other animals like frogs, etc., aestivate during draught and are active during the moist season of the year.

Many animals adapt themselves to the burrowing habit in order to avoid water loss. Birds and mammals migrate when they face the scarcity of water.

### Check your progress

1. Animals which can regulate their body temperature are called \_\_\_\_\_, those which can not maintain constant body temperature are called \_\_\_\_\_.
2. The term \_\_\_\_\_ is used to describe the situations in which metabolism is reduced during winter. \_\_\_\_\_ refers to the reduced activity or dormancy during summer to avoid excess heat in summer.

---

## 22.6 SUMMARY

---

1. Animals are classified as eurythermal or stenothermal on the basis of their tolerance of changes in temperature. Similarly, animals which can regulate their body temperature are called homeotherms; those which cannot maintain constant body temperature are called poikilotherms.
2. Temperature effect on animals may be seen in their behaviour, metabolism, growth, development, size of the body parts, etc. They undergo aestivation (summer sleep and hibernation (winter sleep) to overcome the effects of unfavourable temperature.
3. The non-availability of light affects the metabolism, pigmentation, growth, development, and orientation of the animals. Biological light is called 'Bioluminescence'.
4. The circulation of water between atmosphere and earth's surface is known as 'hydrologic cycle'.
5. A number of adaptations like dry excretion, suspended animation, impervious skin, selective food, change in mode of respiration, type of food, etc., are seen in terrestrial animals to counteract the loss of water.

---

## 22.7 CHECK YOUR PROGRESS -MODEL ANSWERS

---

1. homeotherms, poikilotherms
2. 'hibernation'  
Aestivation

---

## 22.8 MODEL EXAMINATION QUESTIONS.

---

### I. Attempt the following in about 30 lines each:

1. Discuss the importance of temperature and light as ecological factors in animals.
2. Enumerate the adaptations to temperature seen in animals.
3. Give an account of biological light- its occurrence, mechanism of production, and significance.
4. 'Water is the medium of aquatic environment'- Discuss.
5. Discuss homeothermy and poikilothermy.

### II. Write notes on the following in about 10 lines each:

1. Thermal stratification
2. Dormancy
3. Cyclomorphosis
4. Allen's rule
5. Jordon's rule
6. Eurythermy
7. Stenothermy
8. Electromagnetic spectrum
9. Photoperiodism
10. Bioluminescence
11. Universal solvent
12. Hydrological cycle.

---

## UNIT - 23      COMMUNITY STRUCTURE AND ECOLOGICAL SUCCESSION

---

### Contents

- 23.1 Objectives
- 23.2 Community structure
  - 23.2.1 Introduction
  - 23.2.2 Species diversity and dominance
  - 23.2.3 Community Composition
  - 23.2.4 Ecological niche
  - 23.2.5 Community stability
  - 23.2.6 Ecotone and edge effect
  - 23.2.7 Factors compensation and ecotype
  - 23.2.8 Community stratification
- 23.3 Ecological Succession
  - 23.3.1 Causes for succession
  - 23.3.2 Climax
- 23.4 Summary
- 23.5 Check Your Progress - Model Answers
- 23.6 Model Examination Questions

---

### 23.1 OBJECTIVES

---

This unit deals about the community structure. At the end of this unit you will be able to explain about:

- community composition,
- species diversity
- ecological niche
- community stability, stratification etc.,
- the causes of ecological succession, types of succession, climax.

---

### 23.2 COMMUNITY STRUCTURE

---

#### 23.2.1 Introduction

Community is a group of different kinds of populations living in a given area or a physical habitat. Clarke (1967) defined community as the group of plants and animals inhabiting a natural area. It was described as 'biocenose' by mobious (1880). The biotic community along with environment forms the ecosystem.

The components of communities are populations and the population is an assemblage of individuals belonging to a single species. According to Kendeigh (1974), the community may be distinguished as major or minor. Major communities are large, relatively independent and self sustaining units. Major communities are called societies which are dependent on neighboring ones.

A Community has the following characteristics:

### 23.2.2 Species diversity and dominance

Even though all organisms in a community are equally important in their function, relatively few species exert influence by virtue of their number, size, production, etc. Some species are found only in one community - **exclusive species** - whereas others live in many communities - **ubiquitous species**. Of the total number of species in a community very few are abundant in individuals or biomass. The dominant species there-few in number account for the energy flow in each trophic group. But it is the large number of species that determine the species diversity. In a forest community trees are dominant. Grasses play a similar but a restricted role in a prairie community, mussels and barnacles on the rocky sea shore etc.

### 23.2.3 Community composition

- a) **Size:** Communities may be large covering thousands of square kilometers: e.g., Oceanic community. Some may be small like a lake or a desert covering hundreds of square kilometers. Other may have still smaller communities. A horse shoe crab with a dozen species of molluscs, worms and barnacles attached to its shell comprises a microcommunity.
- b) **Trophic Structure:** The trophic structure determines the pattern of movement of energy and nutrients through the community. The major communities may trophic (feeding) levels like those of producers, consumers, transformers and decomposers. Most of the plants are consistent in that they synthesize their food material except a few like epiphytes and insectivorous plants, that consumers are not so consistent. They may eat herbivores or carnivores. Some other animals like frogs show variation. Within the life cycle tadpoles are herbivorous while adults are carnivorous.
- c) **Number and Variety of Species:** Each community maintains a perfect balance between producers and consumers. Each trophic level may be represented by one, few or many species. deep sea or a desert may have few species with a small number of individuals but some habitats having a less number of species and more of individuals in each species can also be seen.

### 23.3.4 Ecological niche

The functional role or the specific position of a species within the community is called the ecological niche. as per Odum, the ecological niche includes not only the space occupied by an organism but also its role in a community, i.e. how it transforms energy, behaves, and responds to physical and biotic environment. Thus the habitat of an organism may be compared to the address of a person and the niche to his profession.

Two aquatic bugs, the notonecta and corixa, may live in one and the same habitat but occupy different trophic niches. Notonecta is an active predator feeding on other animals, while corixa feeds on decaying vegetation.

When the niches overlap to a large extent, natural selection operates through competition and results in the elimination of one species. Generally, no two species in a community occupy the same niche. This phenomenon is called '**Gause's principle**'. In such cases one is always superior to the other and the other is driven out of existence through competition.

Organisms which occupy the same ecological niches in different geographical regions are known as ecological equivalents. For example, the Antelope of N.America is ecologically equivalent to the kangaroo of Australia, since both are grazing herbivores of grasslands. Some species occupy a broad ecological niche. For example man has been a herbivore, a carnivore and an omnivore in most of the time.

### 23.2.5 Community stability

Some communities like tropical rain forest and coral reef are stable. Their populations remain constant over long periods of time. Other communities like Tundra are variable as the environmental fluctuations operate on them. As per Hairston et al (1968), the stability of a community is related to the microenvironment and community diversity.

### 23.2.6 Ecotone and edge effect

The demarcation between two communities is possible when the dominants of adjacent communities show clear differences. Such a junction zone between two or more communities is called 'ecotone'. e.g., border between forest and grassland. Ecotones may be narrow or wide. The ecotone has species seen in both the overlapping communities and the species characteristic of its own. The tendency of the ecotone in possessing the species found in neither of the major communities is called 'edge effect'. For example, the owl depends on the forest for nesting and on grassland for food (field rodents).

### 23.2.7 Factor Compensation and ecotype

Organisms may develop certain adaptations to temperature, light, water, oxygen, etc. Such factor compensation occurs at both species and community levels. Species with wide geographical ranges always develop locally adapted populations called ecotypes which have genetically a different tolerance range and optima in response to environmental factors (odum, 1971). Frogs at one extreme of distribution undergo rapid development at a low temperature while others at another extreme of distribution show a much retarded development at a higher temperature.

### 23.2.8 Community stratification

Stratification refers to the vertical or horizontal layers of organisms and the result of their activities upon the environment.

- a) **Vertical stratification:** In the grassland community three strata, namely, subterranean, floor and herbaceous, may be recognised. The subterranean contain roots of plants and provides permanent residence to soil bacteria, protozoans, nematodes, worms and the burrowing animals. The floor stratum contains vegetation, rhizomes of grasses and animals like insects, reptiles and rodents. The herbaceous stratum is formed of upper parts of grasses and herbs and the animals include a variety of insects, birds and ruminants.

In the pond and lake three zones are recognised which are littoral, mimetic and profundal zones. Vertical movement of plankton affects its distribution. Thus vertical stratification is a common feature of many biotic communities.

- b) **Horizontal stratification:** Singing birds divide the community into territories, and each male of a species establishes and defends an area in which the pair nests and feed. the interaction among the birds has brought about a distribution which is regular rather than random.
- c) **Temporal stratification:** Biotic communities show differentiation (stratification) in time also. Different groups of species occur at different times during the seasonal cycle. Seasonal and daily differentiation occur in forests. One group of insects are active during the day and another group at night and a third group during the twilight transition of morning and evening. The warblers, fly catchers and other insectivorous birds are active during the day; the bats at night and hawks at dusk.

## 23.3 ECOLOGICAL SUCCESSION

When a community comes into existence, it shows growth, reproduction, maturity and senescence and finally death. When it perishes, the area will be occupied by another community. This process of one community replacing another occurs so long as the stable community occupies the area. The process is called ecological succession or ecosystem development. In succession, the entire sequence of communities from its inception to the terminal product is collectively called 'sere' and the individual transitional communities are called 'seral stages' or 'seral communities'. When succession starts from a barren area such as bare rock or open water it is called primary succession. If an advanced successional stage is destroyed and the recovering stages reach the climax community it is called secondary succession. While the primary succession is a long term process, the secondary succession occurs quickly and proceeds rapidly. In the succession the first community or organisms to become established are called pioneer communities'.

### 23.3.1 Causes for succession

The causes for ecological succession may be physical and biotic. The erosion or deposition by wind, precipitation, flowing water, waves etc. from the physical factors of succession. Increase in parasites and predators reduce the abundance of prey. Consumers are reduced due to scarcity food; physical nature of the habitat also changes. After the death of plants the material returned to the soil changes the pH, moisture content, etc. The excretion, dead and decomposed bodies of living being, aeration by burrowers all increase the humic acids. Changes in temperature, relative humidity also tend to alter the community.

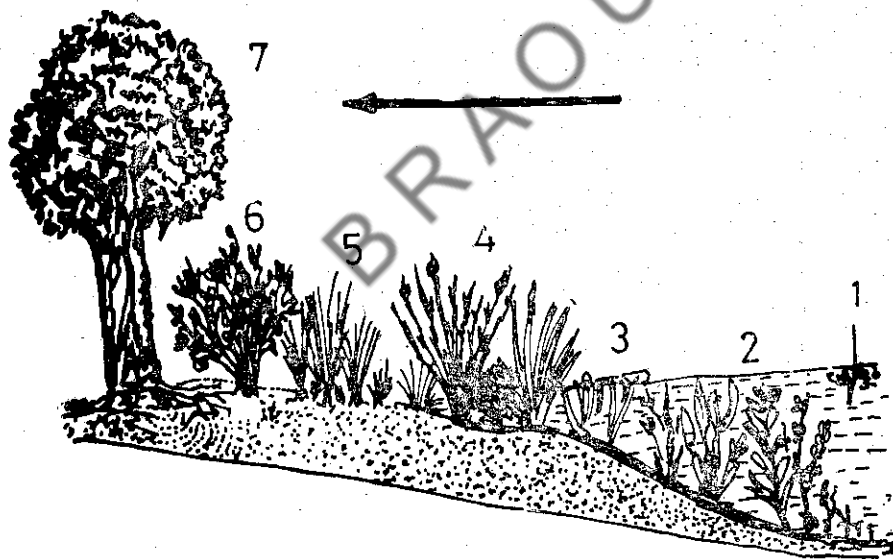

Fig. 23.1 Succession from a pond 1. Phytoplankton 2. Submerged Stage 3. floating Stage 4. Reed Swamp Stage 5. Sedge meadow Stage 6. Shrub Stage 7. Tree climax.

An example of primary succession is a pond and its community getting converted to dryland with entirely different communities. In the pioneer stage the newly formed ponds are barren at bottom, the first organisms to appear are the phytoplankton and zooplankton. They add organic matter to the bottom: The vegetation along the margin may move to deeper water and so the margin of pond also is reduced. some vegetation is carried from an adjacent land. At this stage some submerged plants appear along with certain flies and crustaceans. The death of these plants leads to more humus at bottom and binds with mud. The water becomes

shallow and unsuitable for submerged plants and they are replaced by Pistia, Nymphaea etc. Animals found are snails, beetles, amphibians, etc. Further shallowing of ponds leads to the emergence of water plants, and Mayfly or dragon flies complete their nymphal stages on the submerged stems. Then the water scorpion, water bug and other beetles appear. Annelids, kingfisher like birds ducks, weavers, etc., become common, Animals carry the materials to pond. Plants make the water still shallower, sediment also is washed so that the hydrophytes can grow. These changes bring in the permanent pond to a temporary one which dry up in summer. Then the snails which can aestivate make their appearance. If the climate is dry, a grassland is produced. If it is moist, a woodland with shrubs and small trees are formed.

A volcanic explosion occurred on the 7th of August, 1883 on the Indonesian island Krakatoa causing part of the island to disappear. This may be taken as an example of secondary succession. The remainder was covered with volcanic debris to a depth of 60 meters and light was not practicable. One year later the grass and single spider were found. By 1908 about 202 species have taken up residence on the land. It increased to 880 species by 1934 and a young forest developed on one part of the island. Seedlings of beech, maple and other tolerant species that exist as minor members grow into mature trees with the removal of pines. The pine seedlings are unable to develop in the shade of mature trees. Once the mature pines are gone, the species composition of the forests changes completely paving the way to the emergence of a community of mixed woods. Thus secondary succession originating in the old fields produce a transient community of pines but eventually the typical climax forest was restored.

### 23.3.2 Climax

The community that ends a succession is termed 'climax'. As succession proceeds from the early pioneer community to the climax, productivity tends to increase. There is a difference of opinion among ecologists as to whether the optimum productivity occurs in the serial stages or in the climax stage. Whittaker (1953) states that the productivity is greater in the late serial stages than in the earlier ones while Olson (1963) has found that in many ecosystems, productivity as measured by the accumulation of energy in organic matter will continue to show a net increase until the climax is reached and even beyond. Bliss and Cantilon (1957) have found an increase in productivity from the pioneer to the second stage of development and thereafter a decline. Another way of regarding productivity and succession is to consider the ratio of productivity to the utilization of organic matter by all the organisms of community. During the serial stages productivity is greater than utilization but when the climax is reached, productivity will equal utilization (Olson, 1963).

To summarise, succession involves at least four basic concepts:

1. There is a dynamic shifting of species on the composition of the community.
2. The species changes in an orderly way. It may be possible to predict what type of community would follow an existing one.
3. The sequence of changes of communities is directional. Each succeeding community type is more like the climax type at least in physical characteristics.
4. The ultimate community type is the climax community.

#### Check Your Progress

1. The functional role of the specific position of a species within the community is called \_\_\_\_\_

2. The demarcation between two communities is possible when the dominants of adjacent communities show clear differences. Such a junction zone between two or more communities is called \_\_\_\_\_
3. The tendency of the ecotone in possessing the species found in neither or the major communities is called \_\_\_\_\_

---

### 23.4 SUMMARY

---

1. Community is an assemblage of different populations living in a given area.
2. Community has characteristics like the species diversity and dominance, community composition, ecological niche, and community stability.
3. Community has vertical, horizontal and temporal stratification.
4. The ecological succession can be brought about by physical and biotic factors.
5. Communities usually end in a succession called climax.

---

### 23.5 CHECK YOUR PROGRESS - MODEL ANSWERS

---

1. ecological niche
2. ecotone
3. 'edge effect'

---

### 23.6 MODEL EXAMINATION QUESTIONS

---

**I. Answer the following in about 30 lines:**

1. What is biotic community. Explain its different characteristics.
2. What is meant of ecological succession. Enumerate various processes of ecological succession with one example.
3. Describe the various stages in the development of climax successions in nature.

**II. Answer the following in about 10 lines:**

1. What are the causes for succession.
2. What do you mean by community stratification.
3. Explain ecological indicators.
4. Write about ecological niche with a suitable example.
5. What factors do you consider important in community composition.

---

# UNIT- 24 POPULATION ECOLOGY

---

## Contents

- 24.1 Objectives
- 24.2 Introduction
- 24.3 Biological Attributes
  - 24.3.1 Population Density
  - 24.3.2 Population Growth
  - 24.3.3 Age distribution
  - 24.3.4 Bionic Potential and Environment Resistance
  - 24.3.5 Population Growth Form
  - 24.3.6 Population Fluctuation
  - 24.3.7 Population Regulation
  - 24.3.8 Home Range and Territoriality
- 23.4 Summary
- 23.5 Check Your Progress - Model Answers
- 23.6 Model Examination Questions

---

## 24.1 OBJECTIVES

---

The objectives of this unit is to know the characteristics of population namely the natality, mortality etc. At the end of this unit you will also be able to explain

- the growth form of population and the factors that influence growth.

---

## 24.2 INTRODUCTION

---

According to Krebs (1976) a population may be defined as a group of organisms of the same species occupying a particular area in a given time. The word population is derived from a latin word *populus* meaning 'people'. It is a self regulating system that helps in maintaining stability in ecosystem. The study of population is called demography. The study of number of organisms and the factors that determine their distribution and abundance is called **population ecology**.

The characteristics of a population include: 1. Those that it shares with an organism called biological attributes. 2. Those that are unique of its own-Unique attributes. Mostly these are statistical i.e. the biological features expressed as statistical functions.

---

## 24.3 BIOLOGICAL ATTRIBUTES

---

1. Population has a definite structure and composition at any given time. Any population usually consists of the larvae, juvenile, mature, breeder, the spent; male and female, small, medium and large sized individuals. They may belong to different races, varieties, subspecies etc. Since number of adults, sub-adults, males or females vary from time to time it may be said that the composition of population also varies with time.
2. Population exhibits ontogenic characters in normal conditions. Therefore we can say it has history similar to individuals.

3. Like organisms population has to face the impact of environmental changes.
4. Population grows, differentiates and maintains itself as does the organism.

#### Unique attributes

These attributes are meaningful only at the group level and therefore unique of population and cannot be related to a single individual.

#### 24.3.1 Population density

The density of a population is the total number of individuals per unit area or volume. For ex. 100 trees/ha; 20,000 diatoms/cu m of water not 100 pounds of fish/acre of water surface etc. When size of the individuals of a population is uniform, density is expressed in numbers, when the size is variable then the density is represented as biomass.

Population density is the total number of species within a natural habitat. It is a numerical concept and can be expressed by the equation:

$$D = \frac{n/a}{t} \text{ where } D = \text{Density}$$

n = number  
 a = area  
 t = time

#### 24.3.2 Population growth

The growth form of a population is influenced by natality, mortality and dispersion.

**Natality:** It is the inherent capacity of a population to increase in numbers. it includes the production of new individuals under ideal conditions by means of asexual division germination, hatching or by birth.

Natality is the number of individuals born per female per unit time. In case where individuals are born, the birth rate is equal to natality.

$$\text{Birth rate 'b'} = \frac{\text{No. of births per unit time}}{\text{Average population}}$$

**Mortality:** It is the force that decreases the individuals or it is the population declining factor. As natality is expressed as the rate of gain or birth of individuals in a unit time, mortality is expressed as loss of individuals in unit time or the number dying in a given time. The ratio of death (d) is expressed as;

$$d = \frac{\text{No. of deaths per unit time}}{\text{Average population}}$$

The age at which death occurs is significant because birth rate will fall if death occurs mostly among mature individuals. Further the age of death would alter the structure of population. When more young ones are born than the habit can support, the surplus must either die or leave the area.

specific mortalities at different ages of life history could help in determining the forces underlying the population mortality. A complete picture of mortality in a population can be represented by a statistical device called life table. Life table is the format for describing mortality rates in a population. it was first introduced by Pearl (1921).

Life tables are useful for computing the average longevity of a population, for showing the age composition, for showing differences between species, for showing the critical stages in

life cycle at which mortality is high, for showing success of a species in a biotype, and in the control of pests.

Curves may be plotted from data of life table. The number of individuals of a population at the beginning of age interval are plotted on horizontal and the number of survivors at time interval on vertical and the resulting curve is called survive curve.

In nature three types of survivorship curves are obtained:

1. Convex type, in which population mortality rate is low until the end of life span. Ex. large animals and man.
2. Diagonal or straight line curves are intermediate in which age specific intervals are nearly constant. Ex. bird, mouse, rabbit, holometabolous insect etc.
3. Concave curve in which mortality rate is high during young stages followed by a period of much lower and less constant loss. Ex. Fish, marine invertebrate, parasistes etc.

Most of the animals survivorship curves are intermediate among the above three. Ex. Deer, annelid, Isopod etc.

**Dispersion:** The distribution of animal population in a given space and time is called dispersion. Dispersion is different from geographical distribution because dispersion characterizes natality and mortality.

Dispersion occurs for obtaining food, to avoid predators, prevent the adverse effects of over crowding, as a result of wind, water, temperature, light, breeding, for interchange of genetic material between population.

When less number migrate there is not much change in density, structure and organization of population. But if large numbers move into or out, overpopulation or depopulation occurs.

#### 24.3.2 Age distribution

The relative abundance of organisms of various ages in the population is called age distribution. According to Bodenhheimer (1938) in a population there are three ecological ages viz. prereproductive, reproductive and post reproductive. The relative duration of these ages varies with different organisms. In man these three stages are almost equal. In mayfly there is lengthy prereproductive period. The changes of mortality are more towards early and later periods of life span and reproduction is limited to only middle age group. The ratios of various age groups help in predicting the future size of the population.

**Age pyramids:** It is the means of expressing age distribution. It is the vertical graph showing youngest at the bottom and the oldest at the top. From the age pyramid one can get information whether the population is stable or contracting or expending. If the pyramid shows increased number of juveniles (broad base) it is expanding; if it shows decreased number of juveniles (narrow base) it is contracting. A triangle or bell shaped pyramid represents growing population. Urn shaped pyramids indicate increased number of middle aged and old organisms compared to young. Deviation from the normal distribution may be due to more deaths occurring in one group or due to influx or efflux of individuals.

#### 24.3.4 Biotic potential and environmental resistance

The term biotic potential or reproductive potential refers to the inherent power of a population to increase in number when age ratio is stable and all environmental conditions are optimal. The sum of physical and biologic factors which prevent a species from reproducing at its maximum rate is termed as environmental resistance. This is very low when a species is first introduced into a new territory so that the species increase in brought to United States.

But as the species increases in number the environmental resistance also increases in the form of predators, parasites and the competition between the members for common necessities like food, shelter etc. and consequently the population decreases. An equilibrium will be reached either by decreasing the birth rate of by increasing the mortality rate.

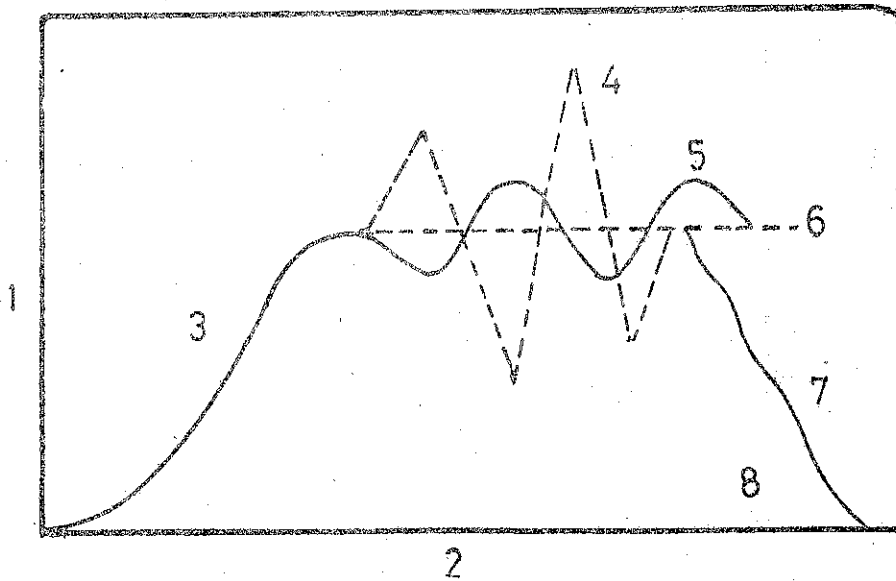

Fig. 24.1 Stylized representation of the various phases of population growth form. 1. Population size 2. Time scale 3. Positive growth 4. Fluctuation 5. Oscillation 6. Asymptote Equilibrium 7. Population decline 8. Population Extinction.

### 24.3.5 Population growth form

Growth is the fundamental dynamic feature that a species population displays. the specific pattern of increase of population is called growth form. Population grows due to increase in number of its individuals. if the increase is plotted against time, a growth curve is obtained. When a few organisms are introduced into an unoccupied area, the growth of the population is at first slow (positive acceleration phase), then becomes rapid (period of logarithmic phase) until the equilibrium level is reached around which the population size fluctuates more or less irregularly depending on the variability of the environment (24.1).

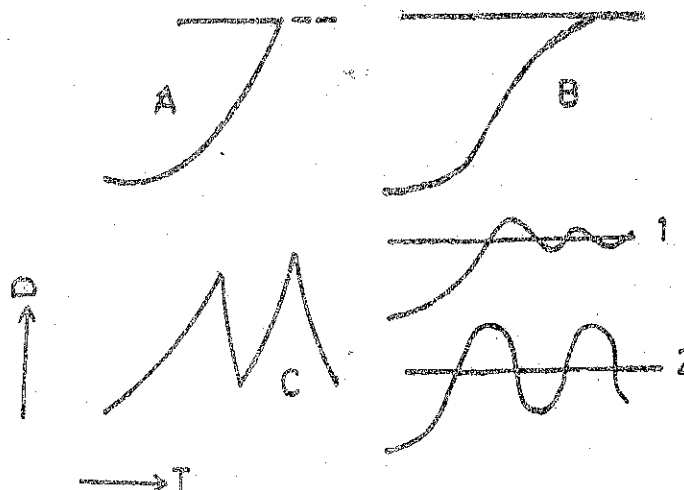

Fig. 24.2 Types of growth forms. A 'J' shaped B. 'S' shaped C. Severe oscillation D. Density. 1. Damped oscillation 2. Undamped oscillation.

Population characteristically increase in size in a (i) sigmoid 'S' shaped or logistic fashion (ii) 'J' shaped

In the 'J' Shaped growth form population density increases rapidly and then stops suddenly. In the sigmoid type it increases slowly and then more rapidly and finally very soon slows down gradually until equilibrium is reached. Simple growth form of a self limiting population is said to be logistic and expressed in the form of 'S' shaped curve called 'logistic curve'. The level beyond which no major increase can occur represents saturation level or carrying capacity (k).

#### 24.3.6 Population fluctuation

When population complete their growth and arrive at asymptote level, the density tends to fluctuate above and below this level. The irregular or asymmetric deviations from the mean numerical stability deviations are called oscillations. The fluctuations may result from changes in physical environment and interaction within the population or between the closely interacting populations. In nature seasonal and annual fluctuations can be noted.

Seasonal changes are typical of most freshwater and oceanic plankton populations ex. plankton blooms. Such blooms are larger in spring and caused as a result of various external nonbiological factors.

Oscillations exhibit regularity for which reason they are referred as cycles. Species exhibiting such cyclic variations are called cyclic species. Oscillations may be the result of intrinsic factors such as predation, disease. Violent oscillations are common in populations which show 'J' shaped growth form and damped oscillations are characteristic of 'S' shaped growth form.

#### 24.3.7. Population regulation

In a simple ecosystem, populations are regulated by physical components of the environment like weather, water currents, floods, storms etc. Many plants and animals have the intrinsic self regulatory mechanisms such as failure of reproduction and self inflicted mortality for controlling the size of the population. Populations grow when natality exceeds mortality and they decline when mortality exceeds natality. The limitation of animal number is affected by the interaction of two processes : density independent and density dependent factors.

The density independent factors are those, the effects of which are independent of size of the population. These are extrinsic factors which tend to regulate the density of a population under different conditions. An increase in the number of species on a habitat say ocean, does not affect the temperature or salinity of water, but changes in these factors are brought about by agents correlated to density. The density dependent factors are intrinsic or biotic. Some of the density dependent factors are competition, reproduction, predation, emigration and disease.

Populations always try to evolve towards self regulation. Direct density dependence can only regulate any population. The effect of combination of factors involved in density dependence may vary widely. further it exhibits a phenomenon called 'inter compensation'. Thus if the predators are removed the herbivores may increase in number and the over crowding results in starvation. A supply of food at this juncture make the individuals susceptible to diseases due to the intensity of over crowding (Wilson & Izosort, 1927). Thus the density independent factors bring about drastic variations in population density and cause shift in carrying capacity, while the density dependent aspects tend to maintain populations at a steady state.

### 24.3.8 Home range and territoriality

Home range is an area which is regularly traversed by an individuals in search of food, mate etc. The portion of it which is actively defended from the entry of the members of the same species is called territory. The territory may be well seen in social organisms like hive of bees, colony of ants, by a breeding pair or by a single individual. Territory is well established in vertebrates and certain arthropods which have complicated reproductive behaviour like nest building, egg laying or protecting the young. The return of an animal to its territory is referred to as homing. This is familiar among birds many species of insects, and certain crustaceans.

#### Check your progress

1. \_\_\_\_\_ is the number of individuals born per female per unit time.
2. Birth rate 'b' =
3. Loss of individuals in unit time or the number dying in a given time is \_\_\_\_\_

---

### 24.4 SUMMARY

---

1. Population is a group of organisms of the same species in an area.
2. Population has two characteristics: the biological and unique.
3. Population growth is influenced by birth rate (natality), death rate (mortality) and dispersion.
4. Population may be classified based on the age distribution.
5. The population shows 'J' or 'S' shaped curves when the density and time are plotted in a graph.
6. Populations may show the period of positive growth, equilibrium, fluctuations (or) oscillations, and period of negative growth or extrinsic.
7. Population is regulated by density independent and density dependent factors.

---

### 24.5 CHECK YOUR PROGRESS - MODEL ANSWERS

---

1. Mortality
2. 
$$\frac{\text{No. of births per unit time}}{\text{Average population}}$$
3. Mortality

---

### 24.6 MODEL EXAMINATION QUESTIONS

---

#### I. Answer the following in about 30 lines:

1. Describe various components of populatiens.
2. Write in detail the characteristics that are exhibited by population.
3. Population is a self-regulating system-Discuss.
4. What is a growth form of population. Discuss how it is altered by various factors.

**II. Answer the following in about 10 lines.**

1. Explain the types of age pyramids.
2. Write about biotic potential.
3. Describe the survive curves of the animal populations.
4. Distinguish 'territory' from 'home range'.
5. Write about age distribution in man and other animals.

BRAOU

---

# UNIT 25 ENVIRONMENTAL POLLUTION – RADIATION HAZARDS

---

## Contents

- 25.1 Objectives
- 25.2 Introduction
- 25.3 Thermal pollution
- 25.4 Air pollution
- 25.5 Water pollution
- 25.6 Noise pollution
- 25.7 Soil pollution
- 25.8 Metal pollution
- 25.9 Radiation Hazards
- 25.10 Summary
- 25.11 Check Your Progress - Model Answers
- 25.12 Model Examination Questions

---

## 25.1 OBJECTIVES

---

The objectives of this unit is to explain the major concepts of environmental pollution and the measures to control it. At the end of this unit you will be able to discuss in detail about the

- sources of air, water, soil and noise pollution and their effect on animals and man
- radiation hazards on human health.

---

## 25.2 INTRODUCTION

---

Environmental pollution may be defined as an undesirable or harmful change in the physicochemical or biological characteristics of biosphere. These changes may directly or indirectly affect man or through his consumption of water and agricultural and other biological products, as well as his physical possessions or his opportunities for recreation and appreciation of nature. Pollution and contamination are the two terms sometimes used interchangeably. Contamination is the presence of harmful substances or organisms that may cause disease or discomfort to a human being. Polluted material need not necessarily be contaminated. The presence of a small amount of pollutants (agents that cause pollution) may have a graded influence on human health.

Pollutants are of two types

1. **Non degradable** : Aluminium cans, Hg salts, phenolic compounds and DOT which do not easily breakdown or change into simpler components. These are stable and accumulate by way of biogeochemical cycles
2. **Biodegradable** : They are unstable substances of domestic sewage which can be decomposed by natural processes. They can be removed by natural waste treatment mechanisms.

Pollutions has been a major cause of hazards and a check is necessary to save human civilization from destruction. it has been observed that because of pollution there is an increase

in mortality and sickness from environmentally concerned respiratory disease, mental disorder, gastric ill effects and cancer. Usually, pollution may be aquatic terrestrial or aerial. A brief account of the sources and health hazards caused by different kinds of pollution in the environment is given hereunder:

---

### 25.3 THERMAL POLLUTION

---

A number of industries require water for cooling and the resultant warm water is discharged into lakes or rivers. The large amount of waste heat that is carried as hot water may cause thermal pollution. It produces distinct changes in the organisms living near the streams or rivers. Increase in temperature by  $10^{\circ}\text{C}$  may double the rate of number of chemical reactions and decay in the organic matter, rusting of iron etc., and finally lead to a significant exchange of salts in the organism. Thus thermal pollution can affect the members of aquatic environment.

---

### 25.4 AIR POLLUTION

---

Air is a mixture of gases consisting of approximately 78-80% of nitrogen, 21% of oxygen, 1% of argon, 0.03% of carbon dioxide and a number of minor gaseous elements like neon, helium, methane, krypton, etc. Owing to some natural processes or human activities the concentration of gases increases in the air and then the air is said to be polluted.

Severe air pollution may affect human health and may be responsible for fatal diseases in them. Lung diseases among coal miners who inhale mine dust for years is a striking example of it. The pollutants may cause many diseases such as Emphysema, chronic bronchitis, lung cancer and respiratory diseases among children. When the levels of pollutants in air increase beyond permissible limits there is an increase in the incidence of bronchitis, sore throat and eye irritations and in frequency of their occurrence.

Air pollution can be caused by the combustion sources, industrial and community activities, personal habits like smoking, etc. The combustion sources include (1) power plants, domestic heating equipment which produce sulphur dioxide, nitrogen oxides and (2) Motor vehicles which produce photochemical oxidant type like carbon monoxide and lead etc. Cigarette smoking is a personal pollution of the inhaled air. It contains a high concentration of CO and polycyclic aromatic compounds such as benzopyrene. It is related to chronic respiratory diseases and the cardiovascular diseases.

Some of the air pollutants are  $\text{SO}_2$ , CO and oxides of nitrogen.

**SO<sub>2</sub>** : Originates from the combustion of coal and generally it induces irritation in respiratory epithelium and in the eyes. It is responsible for cough, pharyngitis, headache, etc.

SO<sub>2</sub> in atmosphere does not for long remain in a gaseous state. It reacts with the moisture to form  $\text{H}_2\text{SO}_4$  and produces acid rain that falls on the earth; the pH values of the rain reaching far below (2.8). Such environmental acidity may affect the fish, and other aquatic animals and inhibit the forest growth.

**CO** : Its main source is release from the gasoline engine and the burning of coal. It combines with Hb to form carboxyhaemoglobin and reduces the oxygen transport. The nervous system is affected at levels of 2.5% of carboxyhaemoglobin.

Symptoms of the low level of CO poisoning are headache and psychomotor impairment. But advanced stages are indicated in nausea, heart palpitations and difficulty in breathing.

## Oxides of Nitrogen

Robinson & Robins (1971) have estimated that biological production of NO and NO<sub>2</sub> amounts to 1 billion metric tons annually while man's combustion processes produce 48 million metric tons of NO<sub>2</sub> annually.

Sometimes the atomic oxygen (O) combines with hydrocarbons (methane, toluene, ethane) in the presence of sunlight and forms the photochemical smog (the combined effect of ozone, formaldehyde, PAN). The eye, nose and throat irritations associated with this type of pollution are felt instantaneously.

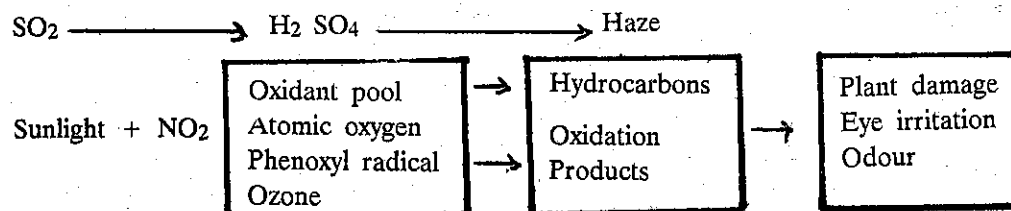

Fig. 25.1 A scheme of the reactions involved in photochemical air pollution

### Measures to control air pollution

1. The devices such as positive crank case ventilation, valve and catalytic converter which reduce exhaust by automobiles are being tried out in some advanced countries.
2. Particulate pollution from industries may be controlled by electrostatic precipitators which are capable of reducing smoke and dust.
3. Gaseous pollutants of industries may be reduced by finding the alternate chemical means based on the property of differential solubility of gases.
4. In India air pollution boards are set up at the Central and the State levels to issue or revoke licences to pollutant generating industries.
5. The legislation to burn garbage and wastes in urban areas and to arrest the burning of smoking fuels for domestic purposes have also been enacted.

## 25.5 WATER POLLUTION

Water is said to be polluted if its composition or condition is altered thereby rendering it less suitable for any or all of the functions and purposes for which it is suitable in its normal state. It includes changes in the physical, chemical and biological properties of water, or such discharges of liquid, gas or solid substances into water which are harmful. Pollution is most often caused by the disposal of liquid wastes (sewage) and agricultural effluents, drainage of irrigation water and urban runoff. Domestic and municipal sewage contains decomposable organic matter that makes a demand on the oxygen resources of receiving waters. This Biochemical oxygen demand (BOD) is a measure of weight (per unit volume of water) of dissolved O<sub>2</sub> consumed in the biological processes that cause decay in the organic matter. BOD values range from 1 mg/litre (natural water) to 300-500 mg/litre (untreated domestic sewage). Water for drinking purposes should have a BOD less than 1. Toxic chemical of the water may originate from industries, agricultural runoff, washing of insecticides, herbicides, radioactive fallout, or leak of oil tanks, etc. Urban run off contains even pathogenic protozoans, bacteria and virus.

Sewage includes dissolved organic compounds and salts such as nitrates and phosphates of detergent and sodium, calcium, potassium and chloride.

Industrial wastes usually contain traces or large quantities of raw materials, intermediate products, final products, co-products and byproducts of any ancillary or processing chemicals used. In India most of the rivers or streams are polluted with industrial effluents. Waste waters of different industries such as petrochemical complexes, fertilisers, oil refineries, synthetic material plants for drugs fibre rubber, plastics etc. may contain detergents solvents, cyanides, heavy metals and organic acids, dyes, pigments, phenolic compounds, tanning agents, sulfides and ammonia. Of the compounds mentioned, many are biocidal and toxic. The chemicals of industrial wastes are toxic to animals like crab snail, effects on the structure and functions of the liver, kidney, reproductive and respiratory system. mercury, a is used in a number of is 0.03 mg/litre, but in the contaminated waters like Minimata bay in Japan, the levels are as high as 1-10 ng/litre. In the 1950's in Japan illness and death occurred among fisherman who ingested fish, crab, shell fish contaminated with methyl mercury from Japanese coastal industries. The mercury poisoning produced a crippling and fatal disease called 'Minimata disease'. In the initial stages, numbness of limb, lip, tongue, deafness, loss of vision, cellular degeneration in brain, cerebral cortex occurred and this led to coma (South wick, 1976). The consumption degeneration and it was reported from Handigdu, karnataka. The disease is identified as Handigodu syndrome.

#### Water related hazards from ingestion of biological agents

The biological agents transmitted through water are pathogenic bacteria, viruses, parasites and other organisms.

Table 2 : Shows disease attributed to ingestion of water borne bacteria

Disease	Causative organisms
Cholera	<i>Vibrio cholerae</i>
Typhoid	<i>Salmonella typhi</i>
Gastroenteritis	<i>Shigella, Proteus sp, etc.</i>
Diarrhoea	<i>Entamoeba coli</i>
Leptospirosis	<i>Leptospira sp</i>

2. **Viruses** multiply in the alimentary tract of man and may be excreted through faeces. The viruses found in sewage and polluted waters are poliovirus, echoviruses, virus of infectious hepatitis, adenovirus and reovirus, etc.,
3. **Parasites:** *Entamoeba histolytica*, the causative agent for intestinal amoebiasis and amoebic liver abscess is present wherever sanitary conditions are poor (WHO committee on amoebiasis, 1969). The guinea worm which causes dracontiasis is transmitted through wells and ponds infested with copepod intermediary host. *Ascaris lumbricoides* may also be waterborne although ingestions of contaminated soil is the main route.
4. **i) Schistosomiasis:** It is a chronic disease, that causes serious pathological lesions, saps energy, lowers resistance and reduces output of work. Artificial lakes, reservoirs, may have increased populations of freshwater snails and a corresponding increase in schistosomiasis. In man three species of helminths *Schistosoma mansoni*, *S. japonicum*, *S. haematobium* are responsible for the incidence of the disease. The eggs released through faeces and urine hatch as miracidia, reach water and make their way into the snails (*Biomphalaria*, *Bulinus*, *Oncomelania*). They emerge from snails as cercaria and enter man through the skin.
- ii) **Ancylostoma duodenale:** It is the round worm responsible for ancylostomiasis. The eggs passed through faeces of infected person hatch and larvae develop into the filariform which is infective to man.

- iii) **Leptospirosis** is by bacterial infection from vertebrates to man through direct contact with water.

Diseases transmitted by water associated insect vectors:

- i) The most widespread is malaria which is caused by water associated vectors.
- ii) **Onchocerciasis or river blindness:** The disease is transmitted by blackflies (*Simulium* sp) and is of considerable economic importance in the vicinity of breeding grounds for vector where large resident populations may become partially or totally blind.
- iii) **Filariasis** caused by **Wuchereria bancrofti**. It is widely distributed in Africa and Asia specially due to increased urbanization and industrialisation. With vast movements of populations and the breeding of the major vectors the mosquito- *Culex pipiens*, *fatigans* have greatly increased.

---

## 25.6 NOISE POPULATION

---

Noise is generally defined as a sound without any agreeable musical quality or as an unwanted or undesired sound. Noise is produced by machines, traffic noise by truck and cars. Use of radio, public address system, music, etc., may pollute the environment. Noise from supersonic jets also produce harmful effects.

### Effects of noise

1. Prolonged exposure to noise is known to lead to deterioration of the internal ear and subsequently deafness.
2. Noise produces annoyance and interferes with rest and sleep.
3. Physiological effects of noise include dilation of pupils, the paling of skin, the tensing of muscles, the diminishing of gastric secretions, increase in diastolic blood pressure, nervousness, irritability and anxiety, hypo or hyper glycemia and effects on the endocrine system. The physical pain results at a level of 140 perceived Noise decibals (PNdB) which is the threshold level of pain. And sound above 70 dB resting for more than 300 milliseconds can interrupt deep sleep.
4. Noise may effect the performance of psychomotor tasks.

### Control of industrial noise

1. Defining permissible sound limits.
2. Measuring the noise at workplace, at source and in reducing the same at source.
3. Creating acoustic zones to prevent air borne propagation of noise.
4. By sound proofing and in using personal protection devices.
5. In communities, traffic constitutes the major noise nuisance and in the house personal equipment like radio, TV, etc. Noise from various forms of transport and its transmission at home may be reduced :
  - i) by controlling the emission of noise.
  - ii) by controlling the transmission of noise through proper planning and the use of traffic engineering techniques.
  - iii) by controlling the reception of the noise at home.

---

## 25.7 SOIL POLLUTION

---

Soil and land pollution is caused by insanitary habits, various agricultural practices, improper disposal of solid and liquid wastes and also by atmospheric pollution.

### Contamination of soil by agricultural chemicals

Fertilizers are used with the intention of raising crops but incidentally may contaminate the soil with their impurities. It can also be polluted with industrial wastes that contain the organic chemicals. In the past few years herbicides, insecticides, and fumigants have brought about a number of changes in the soil.

### Herbicides

A non persistent 2,4 -D and highly persistent 2,4,5-T is used as an indiscriminate killer of vegetation and there is evidence to suggest that 2, 4, 5-T may be about the teratogenicity of human fetuses.

### Insecticides

They are of 3 types, the inorganic, natural substances and synthetic organic compounds. The organic compounds are of 2 types- the *organophosphorous* and *arsenic*. The natural substances are derived from 2 plants. (1) *Rotenone*-from the roots of *Derris elliptica*. It is non persistent but toxic to fish, (2) The flowers of *Chrysanthemum* yield pyrethrum. It is non-persistent and non-toxic to most of the animal groups. In some cases it is an ideal insecticide.

The widely used are organochlorines, e.g., DDT. It is highly toxic to insects; but the freshwater fish also is most vulnerable to it. It metabolizes into DDE AND DDD. Its ability to build up in food chain is well developed as.

In Zooplankton	...	0.4 ppm
Needle fish	...	2.07 ppm
Hérons	...	3.57 ppm
Gulls	...	75.5 ppm

DDT inhibits the  $\text{CaCO}_3$  deposition in oviducts of certain birds and thin shelled eggs.

BHC is a mixture of several isomers of which the  $\gamma$ -BHC (Lindane) is lethal to many animals. Others are dieldrin, aldrin, endrin, endosulphon and heptachlor. A number of them are transformed in the soil.

---

## 25.8 METAL POLLUTION

---

Of the metals important are Cd, Pb and Hg.

### Cadmium

It is not essential for human body. The sources are soil, vegetation and food. It can enter as a contaminant from mines, chemical industries, electroplating, super phosphate fertilizers and cadmium containing pesticides.

Chronic Cd poisoning produces proteinuria and affects the kidney. It is known to affect the testis of laboratory animals and mammals. The cadmium released from mines for contaminated water and paddy. This leads to the out break of an epidemic with is called **Itai- Itai disease (ouch-ouch)** because of the painful symptoms resulting from multiple fractures. Besides skeletal deformation, it leads to loss of body weight,proteinuria and glaucoma.

## Lead

Occurs naturally in plants and soil. Man made sources include lead smelting and refining, brass manufacture, storage batteries,paints,agricultural application of lead arensenate, incineration of lead plastics,etc. It is released in the form of aerosol into the air from automobiles. The average content of lead in human food is 0.2 mg/kg. Although the safe limit for lead is 80 Ug/100g of blood, even at lower levels(30-40 U g/100 g blood) inhibition of enzymes involved in the synthesis of seem can be shown to occur.

## Mercury

Man made sources are mines, alkali plants, pulp and paper, plastic, electronic industries, drugs, etc. Burning fossil fuels and great amounts if it to atmosphere. The level of Hg in blood is striking index of its concentration in the body. In Drosophila organic mercury can produce mutations,chromosomal abberations. Mercury poisoning occurred on a major scale in Japan due to the discharge of industrial wastes in Minimata Bay. **Minimata disease** occur mostly in fisherman who eat the fish containing methyl mercury.

---

## 25.9 RADIATION HAZARDS

---

The discovery of X-rays by W.K.Roentgen and their application in many fields has led to the realization that the radiation has dangerous effects on living cells.

Ionising radiation may be divided into 2 groups:

1. Electromagnetic radiation (X-rays and gamma rays, ;
2. Corpuscular radiations like alpha, beta particles (electrons),and protons which are electrically charged whereas neutrons have no charge. The radiation emitted by these two groups have similar pathologic effects.

### Biological effects of ionizing radiation

Information regarding this is obtained from

1. Patients who underwent diagnostic procedures with X-rays and radioisotopes.
2. Occupationally exposed person (e.g., radiologists, workers involved in mining of radioactive ores).
3. Member exposed to the atomic bomb explosion of nuclear weapons.

**Bacq and Alexander (1961)** have given detailed descriptions of different types of radiation and their biologic effects.

Ionizing radiation influence the biological system in two ways.

1. The effect of highlevels results in death of a severe injury, whereas
2. low levels cause long term effects such as mutations, carcinogenesis which appear months or years after exposure.

The radiation effects are indicated by the onset of illness, early lethality, destruction of bone marrow, damage to intestinal tract associated with diarrhoea, haemorrhage, CNS systems, dermatitis, sterility. But much less is known about the effects of small doses like 100 rad. In respect of how low doses leukaemogenesis and carcinogenesis are at present considered the most serious long term risk. The long term effects following high doses are cataract formation, neurological damage and general shortening of the lifespan.

### **Radiation injury at cellular level**

Even though the nature of the lesions caused by radiation in cells has not been discovered, DNA, RNA, RNA protein complex, cell membranes and related organelles are regarded as the primary targets of radiation injury. It is also evident that nucleus is the most vulnerable part. Cell division is affected even at low level. The available mutagenic effects of radiation suggests that genetic DNA is an important target of radiation.

### **Chromosomes**

As a result of irradiation, the chromosomes at metaphase appear sticky and clumped and the boundaries between them are lost. At anaphase, incomplete separation of chromatids is accompanied by bridges of chromatic material between the cells. This lead to incomplete division of chromosome material in the daughter cells. Another effect is the breakage of chromatids or whole chromosomes. The broken fragments may be deleted or may rejoin the original chromatid or other broken chromatids causing several kinds of chromosomal abberations. e.g., abnormal chromosomes like ring chromosomes multicentric, etc.,

### **Effect on embryos**

The embryos are more sensitive to the action of X-rays in their early phase of development, before the organogenesis. Even if the immediate effect of radiation resulting in cell destruction not much there may be much consequences as malformations.

### **Check your progress**

1. Define the following:
  1. Non degradable
  2. Biodegradable

---

## **25.10 SUMMARY**

---

1. Environmental pollution is an undesirable change in the physicochemical and biological characteristics of biosphere.
2. Pollution is caused by solid, liquid and gaseous wastes. In addition, heat, noise and radioisotopes also contribute to the pollution.
3. Air pollution is mainly from the oxides of sulphur, nitrogen and carbon. When they exceed their tolerance limits they cause deleterious effects on animal and plant life.
4. Water is contaminated by industrial wastes, sewage, agricultural run off and also the presence of pathogenic organisms. Noise is generally defined as unwanted sound. The agricultural chemicals such as pesticides, and herbicides may remain as residues in non-target organisms and finally reach man to cause number of abnormal situations. Certain heavy metals discharged from the industries as effluents also may affect the organisms living nearby.

---

## 25.11 CHECK YOUR PROGRESS - MODEL ANSWERS

---

1. non degradable aluminium cans, Hg salts, phenolic compounds and DDT which do not easily breakdown or change into simpler components. These are stable and accumulate by way of biogeochemical cycle.
2. Biodegradable: They are unstable substances of domestic sewage which, can be decomposed by natural processes. They can be renewed by natural waste treatment mechanisms.

---

## 25.12 MODEL EXAMINATION QUESTIONS

---

### I. Answer the following in about 30 lines.

1. Write an essay on the environmental pollution and its control methods.
2. Describe the sources of water pollution. Enumerate the effect of water pollutants on the aquatic life and on man.
3. Write an essay on air pollution. Discuss the methods to control air pollution.
4. Describe the radiation hazards of human health.

### II. Answer the following in about 10 lines:

1. Enumerate the biological agents that are transmitted through contaminated water.
2. Distinguish nondegradable pollutants from degradable pollutants.
3. What do you mean by thermal pollution.
4. Explain noise pollution.
5. Metal pollution and its effect on biological systems.

---

# UNIT-26 WILD LIFE MANAGEMENT

---

## Contents

- 26.1 Objectives
- 26.2 Introduction
- 26.3 Project Tiger
- 26.4 Gir lion Sanctuary Project
- 26.5 Crocodile Breeding Project
- 26.6 Important Wild Life Sanctuaries and national parks in India
- 26.7 Summary
- 26.8 Check Your Progress-Model Answers
- 26.9 Model Examination Questions
- 26.10 Glossary (Ecology)

---

## 26.1 OBJECTIVES

---

This unit explains the meaning of wild life, the causes for extinction of plants and animals and the management principles. At the end of this unit you will be able to describe in detail about the

- measures taken by Government to conserve the wild life that are endangered
- the importance of sanctuaries and national parks to India
- Objectives, management and the achievements in respect of Tiger project, Gir Lion sanctuary, Crocodile breeding Project.

Wild life refers to animals and birds inhabiting our forests. The love and regard for wild life is a part of India's culture. Yet many of the agencies are faced with the threat of extinction. The wild life in India includes 500 mammals, 3000 species of birds, besides an innumerable number of reptiles, fishes, insects and other animals. Under the schedule I of Wild Life (protection) Act, 1972 as many as 66 species of mammals, 38 species of birds and 18 species of amphibians and reptiles (including 3 species of crocodiles) are held to be as rare and endangered. The cheetah has become extinct. The Bengal tiger population is drastically reduced (from 40,000 to 1827 in 1972). The lion is confined only to a few areas. The deer like Hangul in Kashmir, Swamp deer in M.P are now included in the list of endangered species. The antelope and the black buck which were in thousands some 50 years ago is now confined to small pockets surviving under the strict protection. Among birds, the species which are regarded as having become extinct are the pink-headed duck, mountain quail and Jerdon's courser, (Recently spotted in cuddapah region). The great Indian bustard and the white winged wood duck have become so rare that they may soon become extinct.

The Siberian crane, a visitor to Bharatpur sanctuary ( Rajasthan) in winter, as now found in reduced numbers. The gangetic gharial, the estuarine crocodile are reaching the point of extinction. Even though these are only a few examples, several hundreds of the animals in world have become extinct.

However, extinction is a biological phenomenon depending on the circumstances. Each species exists for a certain period and ultimately becomes extinct. One of the important causes of extinction or depletion of numbers is the destruction of a species as a result of commercial exploitation. Many plants are also subjected to extinction due to the ignorance of their potential and ecological functions. The major causes of extinction in the recent past in respect of both

plants and animals are environmental changes due to the destruction of natural habitats, deforestation, grazing and urbanization.

In an ecosystem producers, consumers and decomposers are linked in food chains. Various food chains are joined at different trophic levels forming complicated food webs. In this intricate food web the function of each organism is important. Destruction of a particular link in the food chain in the web may lead to imbalance which may threaten the existence of man himself. Wild animals are subjected to indiscriminate killings to meet man's needs for flesh, skin, fur for medicinal value, protection of domestic animals from predation etc.

In view of the necessity to conserve wild life the Govt. of India (1952) constituted a Board for wild life. The objectives are a) preserving wild life and b) creating natural parks and sanctuaries.

Under this scene, protection has given to Indian lion, snow leopard Cheetah and others. Later in 1972, the Wild Life Protection Act was promulgated. The Act prohibits hunting, killing, capturing, trapping, injuring wild animals in the forest, and in the public or private lands. The Act has a provision for setting up National parks and sanctuaries where wild life can receive protection. Under this Act :

- i) the hunting of tiger, black buck, leopard, wolf, pangolin, wild buffalo, the great Indian Bustard, crocodile etc, is prohibited.
- ii) the hunting of other animals like cheetah, sambar, gaur, bear etc., is regulated through the issue of licences by the Chief Wild Life Warden.
- iii) in case of violation of the above mentioned, provision is made for imposing of a fine of Rs. 2000/- as penalty and imprisonment for 2-6 years.
- iv) the Act prohibits the trading of live animals, their meat, skin etc.
- v) In the Wild Life Act a new section for the creation of biosphere reserves has been incorporated enabling the Central Govt. to declare appropriate areas as biosphere reserves in consultation with the states concerned.

The man and Biosphere (MAB) programme was evolved with the objectives of (1) maintaining the integrity and diversity of biotic communities of plants and animals within the natural ecosystem, (2) safeguarding the genetic diversity of the species and (3) providing areas for ecological and environmental research, as well as education and training.

#### Legislation

1. The forests and protection of wild life animals and birds are included in the 42nd amendment to the constitution in 1976.
2. Legal and illegal trade of endangered species in India is regulated.
3. The Govt. promulgated in 1980 the Forest Conservation Ordinance which prohibits the conversion of a forest land and diversion to other purposes.
4. A separate Department of Environment was created.
5. A separate training course for wild life management was started at the Forest Research Institute, Deharadun.
6. The Govt. is empowered to declare any area as sanctuary or national park. In India 19 national parks and 202 sanctuaries are in existence
7. In any sanctuary or national park there should be 3 zones:

- i) **Core zone:** Entry into this is restricted except for purposes of research (population estimation, etc).
  - ii) **Intermediary zone** Used by wild Life for grazing. Visitors are allowed into this.
  - iii) **Buffer zone:** The place where facilities for camping tourists are provided.
8. Section 33 of the Wild Life protection Act (1972) authorises the Wild Life Chief Warden to control, manage and maintain all sanctuaries.

Thus the basic idea of establishing sanctuaries is to preserve the ecosystem of forests available in the sanctuary and work in such a manner that a congenial habitat is provided for wild life.

The projects planned for the preservation of endangered species are briefly discussed here under:

---

### 26.3 PROJECT TIGER

---

Tiger conservation in India is attempted not only to save the endangered species but to preserve the biotopes of sizable magnitude. It was initiated as a Central Sector scheme in 1973 with 9 reserves. Two more reserves have since been added and under these 11 reserves the population of tigers has gone up from 268 in 1972 to 613 in 1977. The project covers 2.10 percent of the total forest area (15,800 sq kms) in 10 States. The reserves are Manas (Assam), Palamau (Bihar), Similipal (Orissa), Corbet (U.P.) Ratambhore (Rajasthan), Kanha (M.P.) Melghat (Maharashtra), Bandipur (Karnataka), Sunderban (West Bengal), Periyar (Kerala) and Sariska (Rajasthan).

#### Management

The management strategy has been to identify the limiting factors of the habitat through intensive antipoaching. Fire protection, elimination of cattle grazing, eradication of weeds, soil conservation measures, etc.

The guiding principles of management are as here under:

1. To eliminate all forms of human exploitation.
2. To restore and damage caused by man to the ecosystem and bring it up as close to its natural level of functioning as possible
3. To build up the wild life population upto the intrinsic supporting limit of the habitat. To encourage research on the habitat and wild animals.
4. The project was given the status of a centrally sponsored scheme Later the World Wild Life Fund (WWF) provided financial assistance amounting to US \$ 1 million. It is administered by the steering Committee appointed by Govt. of India. The execution of the project is done by the State governments of respective reserve areas.

#### Achievements

1. Fire breaks are maintained along the external boundaries of reserves and core areas. Several fire observation towers are erected.
2. A communication system is installed to convey messages of anti-poaching, animal monitoring, etc.
3. Relocation of human settlements outside the reserves in order to avoid hindrance to the development of preserves.

4. to provide water, several steps like the construction of dams, digging of seasonal waterholes, deepening of the wells and fitting them with pumps and wind mills,, etc have been done.
5. Grazing has been completely stopped in core areas of all tiger reserves.
6. Improvement in soil conservation measures and the preserving of the environment paved the way of the dispersal of prey and predator populations.
7. One of the main aims of the project is the promotion of research into the wild life. It was taken up the methodology and the programming for monitoring, research and documentation of data were finalised.

Besides conserving tiger and the entire ecosystem, protection is given to other threatened species. The Indian one horned Rhino, clouded leopard, wamp deer, gaur, four horned antelope, black buck, crocodile and Gharial.

---

## 26.4 GIR LION SANCTUARY PROJECT

---

The project area is 258.71 sq. km. The lion population in 1979 numbered 205 including the cubs. Gir forest in Saurashtra of Gujarat is a unique line of the line (*panthera leo persica*), it harbours the remnant populations of many species which once constituted the wealth of India including the spotted deer, sambar, Indian gazelle, nilgai, wild boar and four horned antelope.

The shooting of the species continued till the population was reduced to 15. With adequate timely protection measures the population has increased to 20.

Gir sanctuary faced the problem of over-grazing by domestic live stock specially during the monsoon months. due to this the natural wild animals like sambar, nilgai, etc., have become rare. The natural regeneration of trees left out inhibited by the domestic livestock. In the absence of natural prey lions come to feed on cattle, which led to the owners poisoning the lions. Considering these facts, the govt. of India issued orders in 1971, that a) The sanctuary should be closed to grazing by domestic live stock; b) a physical barrier should be provided for the area; and c) The gir resident maldharis should be shifted to places outside the sanctuary.

### Distinctive Features of the project

In the year 1972 the project was sanctioned by the Govt. of Gujarat with the following objective :

1. To encourage wild life especially the endangered lion in the Gir forests.
2. To preserve all non-human elements of the existing ecosystem in their natural relationship.
3. To minimise human interference and to provide recreational facilities to tourists.
4. to prevent over-grazing.
5. To improve the condition of the maldharis and phase their resettlement outside the sanctuary.

### Results achieved so far

The construction of a wall and the raising of the live hedge along the main block of sanctuary kept out the migratory cattle. The improvement of the habitat and the minimising of the human interference stepped up the wild life population tremendously (see the table given below).

Species	Number of wild animals in Gir as on		
	1970	1974	1977
Panther	-	155	161
Hyaena	-	71	84
Spotted deer	4564	4517	8431
Sambar	278	706	760
Blue bull	1068	1528	2036
Wild boar	109	1922	2365
Four horned antelope	256	977	1042
Gazella	227	195	330
Monkey	-	3938	6895
Lion	177 (in 1968)	180 (in 1974)	205 (in 1979)

## 26.5 CROCODILE BREEDING PROJECT

There are three species of crocodiles in India.

1. Salt water or estuaries crocodile (*Crocodile porosus*);
2. Fresh water swamp crocodile or Mugger (*Crocodylus palustris*).
3. The Gharial (*Gavialis gangeticus*).

As the result of the demand of the luxurious leather market and the use of sophisticated hunting methods the crocodile population has drastically declined. Crocodile hunting is largely banned now in India. The Wild Life Protection Act (1972) lists both species of crocodile and the Gharial in its schedule. According to the FAO report (1974) only management will restore the population of the crocodile quickly and it appear that without management the gharial will become extinct. They have a high fecundity level and long reproductive life and under effective control and sound management, crocodile could rapidly build up their numbers.

A crocodile Breeding project was proposed with the following objectives:

1. To locate the best available areas for crocodiles in India
2. To collect the eggs soon after they were laid and transport them to protected areas for hatching, rearing the young till they attain the size necessary for putting them back in their natural habitat.
3. To improve the technical competence to achieve to objective No. 2 as stated above.
4. To set up a net-work of sanctuaries suited to the three crocodilian species.
5. To build up expertise in the management of wild life sanctuaries throughout the country.
6. Crocodile rearing centres have been developed in eight states. The most important of which are the following :
  1. Satkoshia Gorge wife sanctuary - Orissa - Gharial
  2. Biatarkanika - Orissa - Salt water crocodile

3.	Kukrail	Lucknow	Gharial
4.	Katoh	Chambal river	Gharial
5.	Nandankaman Biological Park	Orissa	All three species
6.	Katernia ghat wild life sanctuary	U.P	Gharial
7.	Sunderbans	West Bengal	Salt Water
8.	Guindy part	Madras	Mugger

So far 27000 gharials have been hatched in the rearing stations. In all 324 gharials, 168 salt water crocodiles and 218 muggers were released into the wild by various centres of crocodile breeding and management projects.

#### Important Wild Life Sanctuaries and national Parks in India

S.No.	State	Name of Sanctuary/ National park	Animals protected
1.	Andhra Pradesh	1. Pakhal Sanctuary (Warangal Dt.)	Tigers & Bison
		2. Tadvai Sanctuary (Warangal Dt.)	Bison, Tiger
		3. Kawal Sanctuary (Adilabad Dt.)	Tiger, Cheetah, Indian gazelle
		4. Kolleru (W. Godavari Dt.) Nelapat, Pulicat (Nellore Dt.) Telineela- puram (Srikakulam Dt.) Pocharam (Medak) Bird Sanctuaries.	Migratory birds like painted stroks, pelicans, flamingos, etc.
		5. Nehru Zoological park Hyderabad. Mahaveer-Vanasthali, Hyderabad. Indira Gandhi Zoo Vizag, Chakali-gattu Deer Park, Guntur	Zoo parks only, with lions. Deer Safari parks and dolphinarium & Marine notcurnal animals complex corner and crocodile breeding farms.
		6. Srisailam- Nagarjunasagar.	Tiger & Crocodiles.
		7. Kinnerasant Sanctuary (Khammam Dt.)	Tiger, Bear and Deers.
		8. Kondapally National Park (Krishna Dt.)	Deer
		9. Crocodile Breeding Center, Hyderabad.	Crocodiles

		10.	Papi-hills Sanctuary (E.Godavari)	Crocodiles Tiger, Bison.
		11.	Ettipothal Crocodile Farm (Guntur Dt.) ,	Crocodiles.
2.	Arunachal Pradesh	1.	Namdapha Wild Life Sanctuary	Deer
		2.	Pakhui Wild Life Sanctuary	Deer
		3.	Lali Chapori Wild Life Sanctuary	Deer
		4.	Itanagar Wild Life Sanctuary	Deer
3.	Assam	1.	Manas (North Kamrup)	Wild buffalo and Rhinoceros
		2.	Kaziranga Sanctuary	Rhinoceros
4.	West Bengal	1.	Jaldapara Sanctuary (Jalpaigiri)	Rhinoceros
5.	Bihar	1.	Hazari-Bagh National Park	Tiger & Horned game Tiger Reserve
		2.	Palmau National Park	
6.	Gujarat	1.	Gir forest Sanctuary	Indian Lion
7.	Karnataka	1.	Bandipur Sanctuary	Elephant & Bison
		2.	Sri Rangapatnam Thittu Sanctuary	Birds (Local & migratory)
8.	Kashmir	1.	Dachigam Sanctuary	Kashmir Stag
9.	Kerala	1.	Periyar Game Sanctuary	Elephant & Bison
10.	Madhya Pradesh	1.	Shivapuri National Park	Chinkara
		2.	Kanha National Park (Mandia Dt.)	Swamp-Deer, Bison & Tiger.
11.	Maharashtra	1.	Taroba National Park (Chanda Dt.)	Tiger, Deer & Boar
12.	Manipur	1.	Kabul-Lampu Sanctuary	Manipur Deer
13.	Nagaland	1.	Itanagar Wild Life Sanctuary	Tiger, Sambar, Elephant and Trgopan Blythe
		2.	Pulie-Bedge Wild Life Sanctuary	Tiger, Sambar, Elephant and Tragopan Blythe

14.	Orissa	1.	Simlipal Tiger Reserve	Tiger, Deer
15.	Rajasthan	1.	Bharatpur (Bird) National Park	Migratory birds
		2.	Rathambore and Sarike Tiger Reserve	Tiger
16.	Tamilnadu	1.	Mudumalai Sanctuary	Elephant & Bison
		2.	Vedanthangal Bird Sanctuary	Migratory Birds
17.	Uttar Pradesh	1.	Corbet National Park	Elephant & Tiger
		2.	Chandraprabha Sanctuary (Varanasi)	Introduced Lion
		3.	Rajaji Game Sanctuary (Saharoapur)	Introduced Lion
		4.	Dudhwa National Park	Tiger
		5.	National Chambal Sanctuary	Crocodile

#### Check Your Progress

1. What is Wild Life Protection Act

---

### 26.7 SUMMARY

---

1. To understand the meaning of wildlife, the causes for extinction of plants and animals and the management principles.
2. Measures taken by government to conserve the wild life that are endangered.
3. To understand the importance of sanctuaries and national parks in India.
4. To know the objectives, management and the achievements in respect of Tiger project, Gir Lion sanctuary, crocodile breeding project.

#### Synopsis

1. Wild life refers to the animals of forests, birds, reptiles, amphibians, fishes and the plants that we come across in our surroundings.
2. Some of the animals, facing the threat of extinction are Bengal tiger, Lion, Hangul deer in Kashmir, Swamp deer in Madhya Pradesh, Black buck, pink dreading duck, mountain quail, Siberian crane etc.
3. To preserve wild life and to create natural parks and sanctuaries wild life board was constituted in India in 1952.
4. Wild life was included in 42 and amendment of the constitution in 1976.
5. Several projects have been launched to protect the endangered animals.

---

## 26.8 CHECK YOUR PROGRESS - MODEL ANSWER

---

1. In 1972, the wildlife protection Act was promulgated.

The Act prohibits hunting, Killing , capturing , trapping injuring wild animals in the forest, and in the public or private lands. The act has provision for setting up National parks and sanctioners where wild life can receive protection.

---

## 26.9. MODEL EXAMINATION QUESTIONS

---

### I. Answer the following in about 30 lines

1. Write an essay on wildlife management.
2. What measures do you suggest for conserving the endangered species.
3. Name a few sanctuaries, their location and the animals protected under each of them.
4. List out the important endangered species of mammals.

### II. Answer the following in about 10 lines.

1. What is the significance of 'Tiger project'.
  2. What is the importance of Gir lion sanctuary.
  3. How crocodiles conserved under Crocodile breeding project.
  4. Write about National parks in India.
- 

## GLOSSARY

---

(Evolution and Zoogeography)

Achelulean	Lower paleolithic culture characterised by bifacial tools with round cutting edges.
Apes :	Tailless or shor ttailed old world, Semi erect primates also known as anthropoid apes. Gorilla, chimpanzee Gibbon etc.
Artefacts (artifats)	Simple object (as a tool or ornament) showing human work hum,an work man ship - a product of any civilization.
Aurignacean	Upper paleolithic culture marked by finely made artefacts of stone and bone, paintings and engravings.
Biogenesis	Living things come from living things.
Beagle	Name of the ship in which Darwin travelled.
Blastula	Stage of development when embroy is a hollow sphere of cells arranged in a single layer.
Blubber	A layer of thick fat under the skin of whales.
Backward bulge of cranium	Asign of higher human development whereby the of cranium brain projects behind the foremen magnum and consequently the cranium also bulges correspondingly.

Barrier	A factor that tends to restrict the free movement, mingling or interbreeding of individuals or populations. Generally refers to a material or physical object or set of objects that demarcates or serves as an obstruction.
Crust	Upper surface of the earth.
Cervical Vertebrae	Vertebrae present in the neck region of vertebrates.
Continental Islands	Usually large islands situated close to main land masses and which are known to be in physical contact with them in the past.
Continental shelf	A shallow, submarine plane of varying width forming a border to a continent and typically ending in a steep slope to the oceanic abyss.
Discontinuous distribution	A peculiar type of distribution where a closely related group of animals are situated in widely separate areas on the earth.
Dispersal	The process or the result of spreading of organisms from one place to another.
Diastema	A space between teeth in a jaw, especially refers to the gap between the incisors and premolars and particularly in circumstances where canine tooth is absent.
Digitigrade	Walking on the digits with the posterior of the foot more or less raised. (Cats, Dogs etc are examples)
Foremen magnum	The opening in the skull through which the spinal cord passes to become Medulla oblongata, the hind most part of the brain.
Gastrula	Two layered and later three-layered embryonic stage of development.
Gene frequency	Number of occurrences of character representing a gene in a population.
Glacial age (Ice age)	A time of wide spread of glaciation or advance of ice sheets from the poles (This was pleistocene age- also called age.)
Hernia	A protrusion of an organ or part, through connective a wall of the cavity in which it is normally enclosed or located.
Hypsodont	Teeth of the category having high crowns as in horse.
Isolation	Separation of one species from another so that they are unable to interbreed. It may be due to distance or some barriers.
Island fauna	Having a restricted or is date natural range or habitat in (generally) oceanic islands.
Mutation	A stable change of a gene such that the changed character is inherited by off spring cells.
Mimicry	The resemblances of organisms to others or inanimate objects in form, colour or action. A protective adaptation.
Mousterian	Lower paleolithic culture characterised by well made flask tools often considerable the work of Neanderthal man.

Natural selection	Intensive selection by nature weeding out unadapted forms and bringing out modifications through successive generations which make the organism fit to live in an environment.
Nictitating	Thin, transparent eyelid-like membrane in aquatic vertebrates which opens and closes laterally on eyeball.
Nuchal crests	See sagittal crests.
Origin	The act of being created or born. Every species must have a "slow"beginning one or other area of the world at one time or other.
Prodigality	Tendency of producing large number of offspring by asexually or sexually.
Patagium	Wing-like expansion of skin between digits of the forelimb and other parts of body which helps in gliding movements.
Pneumatic bone	Hollow, vacuolated bone which is filled with air.
Plantigrade	Walking on the sole with the heel touching the ground as in man or bear.
Population pressure	The organisms inhabitation a particular locality i.e. a group of interbreeding organisms is called as a population . When a particular or given geographic area is unable to support the increased number of population, the pressure is said to build up.
Rumen	First part of the stomach in cud-chewing herbivorous mammals with two or four digits.
Rattle	Epidermal modification of end part of tail in rattle snake. It becomes hollow and dry. Produces warning sound when snake moves.
Receding forehead	A primitive human character. In modern men this is vertical . In primitive forms or species the forehead slopes back or recedes back restricting the development of fore brain. The seat of intelligence or modern man.
Struggle for Survival	Survival of the fittest. Competition between all organisms, between individuals and physical environment.
Serological tests	Precipitative tests. Tests conducted on the blood plasma of different organisms to know their closer kinship.
Synthetic Theory	Modern theory of evolution.A proper blending of theory of Natural selection of Darwin and theory of inheritance by Mendel.
Selection	Natural selection explained by Darwin.
Sagittal crests	Elevated part of the skull in the region of skull . A primitive human character where powerful neck muscles are attached .
Simian gap	A strong wedge in the incisors and canines in the upper jaw of apes into which the lower canines fit . This is absent in the humans.
Simian shelf	A strong wedge in the front part of the lower jaw of Apes to support the canines and grinding teeth. This absent in human species.

Supra orbital ridges	Bony ridges situated above the orbits. This is a prehuman or primitive human, and simian character.
Thyroid gland	Endocrine gland situated in the neck region of vertebrates. It secretes thyroxine hormone containing iodine which promotes growth and metamorphosis.
Unguligrade	Walking on the tips of digits or hoofs as in cattle horses etc.
Variation	Differences between two organisms, or parts of organisms.
Wallace line	A hypothetical or imaginary line or boundary separating the diatic fauna from those of Australasia (as well as flora) and forming a common boundary of Australia and oriental. Biogeographic regions. (See the Text for this as well as Lydekker's and Weber's lines).

---

## GLOSSARY

---

### (Ecology)

Abiotic factor	Ecological factors of nonliving nature.
Aestivation	A situation in which organisms spend the unfavourable seasons.
Autotrophic	Organism capable of producing organic materials from inorganic materials.
Association	Unit in community characterized by uniformity of species composition.
Benthos	Organisms resting at the bottom sediments.
Biological clock	Occurrence of processes in organisms in a rhythmic way.
Biochemical oxygen demand (BOD)	Amount of dissolved oxygen required by micro organisms in water.
Biodegradable	Capable of being decomposed by bacterial action.
Characteristic species	Species limited to certain community so that they can be used to identify the type of community.
Climax	The community capable of perpetuation under the prevailing climatic and edaphic conditions.
Community	Groups of population of plants and animals living together in a given space.
Carrying capacity	It is the density level at saturation or equilibrium.
Competition	An interspecific or intraspecific interaction
Chlorinated hydrocarbons	Synthetic organic compounds containing Carbon, Hydrogen and Chlorine ex. DDT, chlorane, Dieldrin etc.
Density	Number of individuals in relation to space.
Epilimnion	Upper layer of warm water in a stratified lake.

Ecosystem	It is a unit of biosphere consisting of living and nonliving substances interacting to produce exchange of materials between them.
Ecotone	Transition Zone between the diverse communities.
Ecotype	A sub species adapted to a particular set of environmental conditions.
Erosion	Wearing away of earth's surface by wind and water.
Hypolimnion	Lower layer of cold water in a stratified lake.
Herbicide	Chemical that kills or injures plant life.
Lentic habitat	Habitat with standing water ex.,pond.
Lotic habitat	Running water bodies ex.,spring,interface.
Littoral zone	Shallow water region with light penetrate to bottom.
Limnetic zone	Water zone with effective light penetration.
Life Table	Tabulation presenting complete data on mortality rates of a population.
Logistic curve	'S' Shaped growth curve of a population.
Neuston	The organisms which live at air water interface.
Nekton	Large active swimming organism.
Plankton	Animals or plants which can not overcome currents.
Phytoplankton	Plankton forms of plant material.
Periphyton	Animals or plants that are clinging to stem or leaves or rooted plants.
Profundal zone	Water zone at the bottoms beyond the penetration of light.
Photoperiodism	Responses of animals and plants to light and darkness .
Population	Group of interacting individuals in a given space.
Pesticide	An agent that kills the pest Ex.Insecticide.
Pollution	An unfavourable alteration of the environment.
Radiosotope	An isotope that disintegrates emitting radiation energy.
Synecology	Community ecology
Self regulation	Population regulation in which the increase is prevented by the internal adjustments in behaviour , physiology within the population .
Thermocline	The subsurface layer of the lake.
Thermoregulation	Regulation of constant body temperature.
Territory	An area that is defended against the intrusions of others of same species.
Teratogen	A chemical substance that can cause developmental malformations in an embryo or foetus.
Zooplankton	Plankton forms of animals.

---

**BLOCK – VI**  
**PHYSIOLOGY**

---

BRAOU

---

# Unit - 27 CARBOHYDRATES, PROTEINS AND FATS - BIOLOGICAL OXIDATION

---

## Contents

- 27.1 Objective
- 27.2 Introduction
- 27.3 Carbohydrates
  - 27.3.1 Classification of carbohydrates
- 27.4 Proteins
  - 27.4.1 Structure of proteins
- 27.5 Lipids
  - 27.5.1 Classification of Lipids
- 27.6 Biological Oxidation
- 27.7 Summary
- 27.8 Check Your Progress - Model Answers
- 27.9 Model Examination Questions

---

## 27.1 OBJECTIVES

---

This unit is to know the basic chemical composition of living organisms and their chemical nature.

By the end of this unit you will be able to describe:

- carbohydrates, classification of carbohydrates and their metabolism
- similarly proteins and lipids, their classifications and metabolisms
- and Biological Oxidation.

---

## 27.2 INTRODUCTION

---

All living organisms are mainly composed of organic substances like carbohydrates, proteins, fats and nucleic acids. Besides, minerals like sodium, potassium, calcium, phosphorous, iron etc., are also present in the living organisms.

As you know, food is an essential requirement for animals, to get energy for sustaining, the growth and maintenance. Food is also mainly consists of carbohydrates, proteins, fats, minerals, vitamins etc., plants synthesise carbohydrates by way of photosynthesis and this becomes basis for the production of rest of the organic substances. Animals get these food substances directly or indirectly from the plants.

In this present chapter it is attempted to discuss the basic chemical nature of carbohydrates, proteins and fats. And also an elementary idea of their metabolism and functional significance will also be discussed.

---

## 27.3 CARBOHYDRATES

---

Carbohydrates serves a as a main source for energy for all living organisms. Substances like sugars and starch are some of the best examples for carbohydrates. Chemically speaking

carbohydrates generally consists of carbon, hydrogen and oxygen elements in their molecules in the proportion of 1:2:1 and can be represented by a general formula.

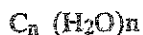

Carbohydrates may be defined as aldehyde or ketone derivatives of polyhydric (more than one-OH group) alcohols or as compounds that yield these substances on hydrolysis.

### 27.3.1 Classification of Carbohydrates

Generally carbohydrates are classified as mono, di and polysaccharides, based on the number of saccharide units present. The term saccharide is coined for some carbohydrates like sucrose (cane sugar), glucose, fructose etc. because of their nature of sweetness.

#### 1. Monosaccharides

These are also oftenly called as simple sugars, which can not be further hydrolysed. Monosaccharides are basic units of carbohydrates, depending upon the number of carbon atoms. They may be subdivided into trioses, tetroses, pentoses, hexoses or heptoses and as aldoses or ketoses depending upon whether the aldehyde or ketone group is present.

	Aldoses	Ketoses
Triose (C <sub>3</sub> H <sub>6</sub> O <sub>3</sub> )	Glycerose	Dihydroxyacetone
Tetrose (C <sub>4</sub> H <sub>8</sub> O <sub>4</sub> )	Erythrose	Erythrulose
Pentose (C <sub>5</sub> H <sub>10</sub> O <sub>5</sub> )	Ribose	Ribulose
Hexose (C <sub>6</sub> H <sub>12</sub> O <sub>6</sub> )	Glucose, Galactose	Fructose

The most important hexose sugar is glucose, which is an ultimate energy resource. The structure of glucose is given as a straight chain and the naturally occurring form (Fig. 27.1)

#### 2. Disaccharides

Yield two molecules of the same or of different monosaccharides when hydrolysed.

Eg: Sucrose, Lactose, (Milk Sugar), Maltose. For example, on hydrolysis sucrose gives rise to glucose and fructose, where as maltose gives two molecules of glucose.

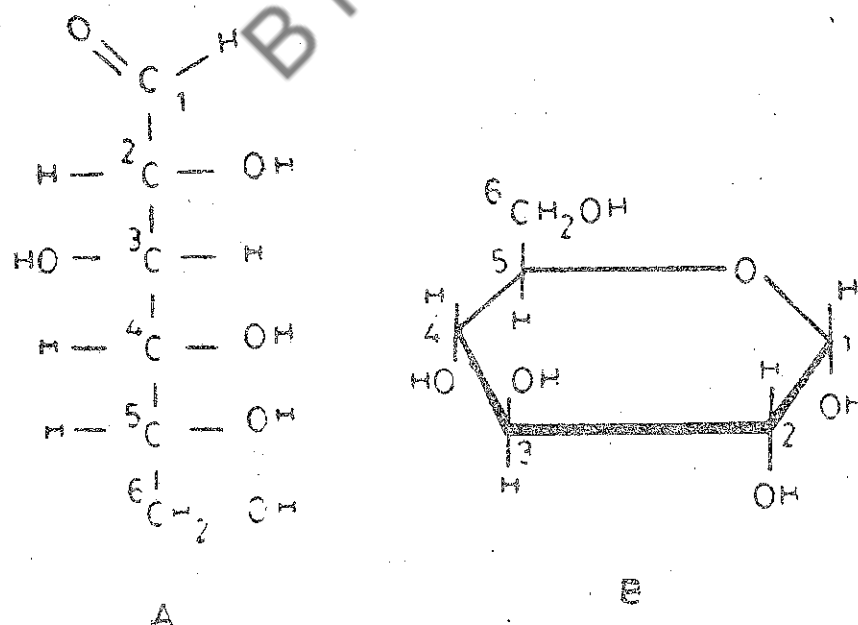

Fig. 27.1 Structure of glucose A. Open chain structure B. Cyclic structure.

### 3. Oligosaccharides

Yield three to six monosaccharide units on hydrolysis.

Eg: Raphinose (Trisaccharide) Verbascose (Pentasaccharide).

### 4. Polysaccharides

Polysaccharides consist of a long chain of monosaccharide units. On hydrolysis yield more than six monosaccharides on hydrolysis.

Eg: Starch, Cellulose, Glycogen (Animal Starch).

### Metabolism

Animals get carbohydrates through food. After digestion, they will be absorbed into blood circulation as glucose and finally reaches tissues. In tissues the oxidation of glucose yields energy rich substances like ATP (Adenosine triphosphate). During the process of oxidation, the glucose molecule is first converted into pyruvic acid by glycolysis. In the presence of oxygen the pyruvic acid is further broken down to CO<sub>2</sub> and water by way of citric acid cycle (Also called as kreb's cycle) in mitochondria.

The glucose can also be stored in the form of glycogen in liver and muscle and converted to fat in the adipose tissues.

---

## 27.4 PROTEINS

---

Proteins form the most important constituents of the animal body. They account for about one half of the total dry weight of the body. Amino acids are the basic units of proteins. There are twenty different amino acids generally present in proteins. Amino acids are classified as essential and non-essential amino acids. Essential amino acids are those that cannot be synthesised by the animal body and has to depend on plants.

Amino acids are generally consist of carbon, nitrogen, hydrogen and oxygen. In addition to that, they also contain sulfur.

Essential amino acids are leucine, isoleucine, lysine, methionine, phenylalanine, thereonine, tryptophan, valine, arginine and histidine. Non-essential amino acids are alanine, aspergine, aspartic acid, cystine, glutamic acid, glutamine, glycine, proline, serine and tyrosine.

Amino acid is generally represented as:

R

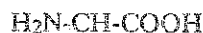

Here 'R' represents the alkyl or aryl chain present in the amino acid. - COOH represent the acidic group, where as - NH<sub>2</sub> represent the basic group.

Depending upon the chemical nature (i.e., 'R'), amino acids are divided into neutral, acidic and basic amino acids.

Neutral amino acids	:	Leucine, Phenylalanine Cystine.
Acidic amino acids	:	Glutamic acid. Aspartic acid.
Basic amino acids	:	Lysine, Arginine, Histidine.

### Peptide

The peptide bond is one that combines two amino acids. Peptide bond is formed by the combination of one carboxyl group (-COOH) of one amino acid) one with the amino group (-NH<sub>2</sub>) of another amino acid, yielding a water molecule.

Example :

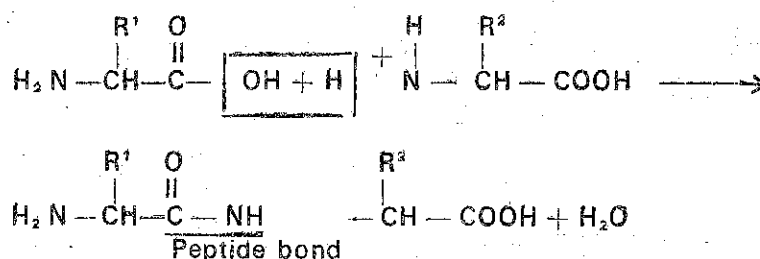

Many such peptide bonds between different amino acids give rise to proteins.

### 27.4.1 Structure of Proteins

Protein structure can be considered at levels of organisation.

#### 1. Primary structure

It is the sequence of amino acids arranged in the protein molecule.

#### 2. Secondary structure

It is the folding of polypeptide chains into coiled or plated structures held together by hydrogen bonds-or folding stabilized by disulphide bonds.

#### Tertiary structure

It is a long peptide chain coiled and variously folded in itself resulting highly specific three dimensional configuration by the various weak molecular forces within the protein. The various forces involved in the maintenance of tertiary structure are hydrogen bonds, Van der Waal's forces, disulphide bridges and ionic bonds.

#### 4. Quaternary structure

The union of different polypeptides to give a functionally active molecular structure.

Eg: Formation of Haemoglobin from four polypeptide chains

#### Metabolism

In animals, after protein digestion, the amino acids are absorbed into the blood circulation and reach liver and other tissues. In liver, the amino acids can be utilised for energy production. In the process of amino acids break down the ammonia formed from the amino group is converted to urea and will be excreted. Besides, the amino acids are also utilised for the protein synthesis and other biologically important substances.

---

## 27.5 LIPIDS

---

Lipids are important dietary constituents. They include fats, waxes etc. The name 'lipid' is given to these heterogeneous compounds because of their insoluble nature in water. But generally, they dissolve in organic solvents like chloroform ether and alcohol. Lipids also have elements carbon, hydrogen and oxygen like carbohydrates. In addition to above elements lipids also oftenly constitute of phosphorous and nitrogen. Since, the carbon, and hydrogen ratio to oxygen C, H: O in lipids is higher than carbohydrates, the energy yeild is more per gram in lipids to carbohydrates.

Substance	Energy yield per gram of substance
Fats	9.3 Calories
Proteins	4.1 to 5.3 Calories
Carbohydrates	4.1 Calories

### 27.5.1 Classification of Lipids

Depending upon the complexities, lipids are classified into three main groups:

#### 1. Simple lipids:

They are the esters of fatty acids with glycerol. Example Triglyceride.

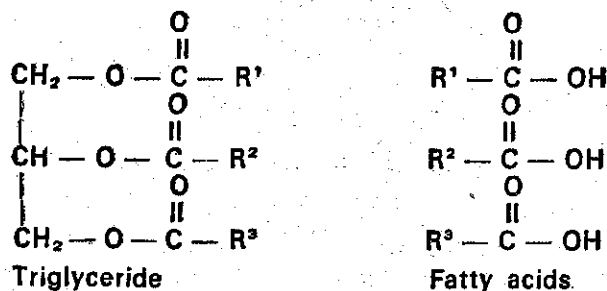

In the above structure the  $\text{R}^1, \text{R}^2$  and  $\text{R}^3$  represent the different hydrocarbons.

There are some esters of fatty acids with higher molecular weight alcohols. Eg: Waxes.

#### 2. Complex (or compound) lipids

These are esters of fatty acids containing not only glycerol but also contains phosphates, sugars and sulphates.

Lipids containing phosphate group are called phospholipids. Example : Phosphotidic acid.

Lipids containing sugars are known as glycolipids. Example Cerebrosides and gangliosides.

There are other lipids like sulpholipids which contain sulphate and amino lipids which contain amino group.

#### 1. Derived lipids

Substances derived on hydrolysis from the above lipids are known as derived lipids. They include fatty acids, glycerol, steroids etc.

##### Fatty acids

Lipids on hydrolysis yields fatty acids. Depending upon the presence or absence of double bond in its molecular structure, fatty acids are classified into saturated and unsaturated fatty acids.

##### Saturated fatty acids

In these fatty acids the bonds between carbon atoms are saturated. Saturated fatty acids occur in abundance in all naturally occurring fats.

Example Butyric acids, Palmitic acids, Stearic acid.

##### Unsaturated fatty acids

In these group of fatty acids, some of the carbon-carbon bonds are not saturated i.e. they contain double bonds. Hence, they can be reduced to saturated fatty acids by way of hydrogenation.

Eg: Oleic acid, Palmitoleic acid, Arachidonic acid etc.

## STEROIDS

These are not true fats and they are the derivatives of parent nucleus known as perhydro Cyclopentanophenanthrene ring with 17 carbon atoms, with three six membered ring and one five membered ring.

Eg: Cholesterol, Male and female sex hormones, vitamin-, Adrenal cortical hormones etc.

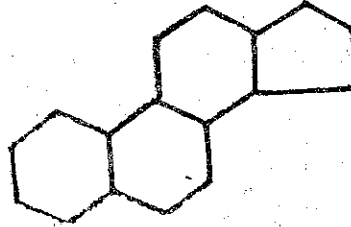

Fig 27.2 Perhydro Cyclopentanophenanthrene

### Metabolism

After lipid digestion, the fatty acid and glycerol are absorbed and transported to various tissues in the body. These are again utilised for the production of synthesis of various types of lipids in the body. Pathway for fatty acids in the  $\beta$ -oxidation, where by the high energy reducing substances like NADH is formed. These energy rich reducing substances produce energy in the presence of  $O_2$

## 27.6 BIOLOGICAL OXIDATION

The food stuff i.e., proteins, fats, carbohydrates in their final degradation process follow a common pathway. During this pathway they are oxidised in living systems in the presence of  $O_2$  to yield chemical form of energy to build and maintain structure. The chemical reactions that occur during the process of biological oxidation are mainly oxidation and reduction reactions. During the process of oxidation the hydrogen ions ( $H^+$ ) along with the electrons ( $e^-$ ) are removed from substrate. The hydrogen ions and the electrons that are released during the process of oxidation are transferred to substance like NAD and FAD. In turn, these NAD and FAD are reduced to  $NADH^+$  and  $FADH_2$ . This reaction is called as reducing reaction. Thus, oxidation reduction process will be facilitated during biological oxidation.

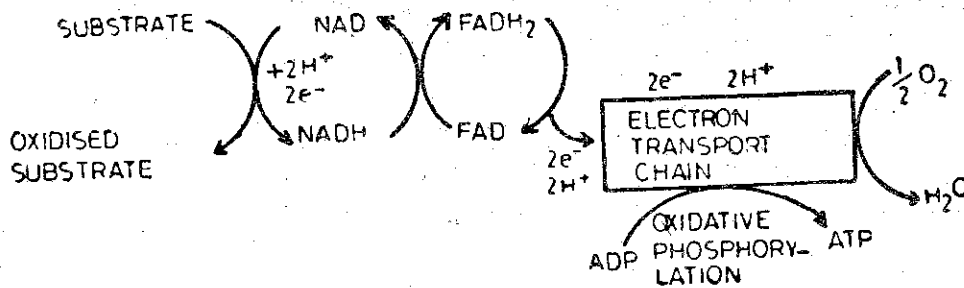

Fig 27.3 Diagrammatic representation of showing energy release during the process of biological oxidation.

The hydrogen ions and electrons that are resulted during the oxidative reductive reactions flow through the electron transport chain present in mitochondria. The electron transport chain consists of various electron carriers like cytochromes and the necessary enzymes to transfer the electrons. During the process of electron transport, the energy is trapped by ADP and converted into energy rich compounds like ATP. Thus, there is a coupling of oxidation to phosphorylation. This process is called **oxidative phosphorylation**. During the electron transport chain, the electrons are finally accepted by the molecular oxygen to liberate water. To conclude, the ultimate aim of the biological oxidation is to produce high energy rich substances like ATP. To quote an example, take glucosed. When one glucose molecule is completely oxidised to give CO<sub>2</sub> and water, it gives a total number of 38 ATP molecules.

#### Check Your Progress

I. Match the following

- |                       |     |                                        |
|-----------------------|-----|----------------------------------------|
| 1. Glucose            | ( ) | a. degradative pathway for fatty acids |
| 2. Peptide bonds      | ( ) | b. unsaturated fatty acids             |
| 3. $\beta$ -Oxidation | ( ) | c. Monosaccharide                      |
| 4. Oleic acid         | ( ) | d. Proteins                            |

---

### 27.7 SUMMARY

---

1. Living organisms are mainly composed of carbohydrates, proteins and fats.
2. Carbohydrates forms the main source of energy for the living organisms. Glycolysis and citric acids cycle are important pathways in carbohydrate metabolism.
3. Proteins are the building blocks of the animal body. They consists of amino acids.
4. Lipids mainly consists of fatty acids and lipids yield more energy.
5. Biological oxidation provides chemical form of energy to build and maintain life.

---

### 27.8 CHECK YOUR PROGRESS - MODEL ANSWERS

---

- I. 1. c 2. d 3. a 4. b

---

### 27.9 MODEL EXAMINATION QUESTIONS

---

I. Answer the following in about 30 lines :

1. What is biological oxidation?
2. Give an account on classification of carbohydrates ?
3. What are proteins ? Add a note on the structure of proteins.

II. Answer the following in about 10 lines

1. What are amino acids ?
2. Write briefly on the classification of lipids.
3. Write briefly on the classification of proteins.

---

# UNIT - 28 VITAMINS AND MINERALS

---

## Contents

- 28.1 Objectives
- 28.2 Vitamins
  - 28.2.1 Introduction
  - 28.2.2 Classification of Vitamins.
- 28.3 Minerals
- 28.4 Nutritional Requirements and Balanced Diet.
- 28.5 Summary
- 28.6 Check Your Progress – Model Answers
- 28.7 Model Examination Questions.

---

## 28.1 OBJECTIVES

---

This unit deals with the nutritive value of Vitamins, macro elements, sources and their deficiency symptoms. By the end of this unit you will also be in a position to explain.

- based on the caloric value of foods the nutritive requirements,
- and balanced diets.

---

## 28.2 VITAMINS

---

### 28.2.1 Introduction

Vitamins as you know are an assorted group of chemicals essential for the maintenance of normal metabolic functions. In addition to carbohydrates, lipids, proteins, inorganic salts and water, normal growth and good health requires the presence of additional compounds in diet. These "accessory food factors", called vitamins may be defined as "potent organic compounds"; although only minute amounts are necessary.

The term 'Vitamins' derived from 'Vital Amines' was coined by Funk (1911) to describe these accessory food factors, which he thought contained amino-nitrogen. It is now known that only a few of these substances contain amino-nitrogen and the word has been shortened to 'Vitamins', a term which has been universally accepted as a group name.

Early studies on the vitamins emphasized the more obvious pathologic changes that occurred when animals were maintained on Vitamin-deficient diets. Increased knowledge of the physiologic defects and consequent diseases is of an applied interest.

### 28.2.2 Classifications of Vitamins

The vitamins are generally divided into two major groups: fat soluble and water-soluble. The fat soluble vitamins are A,D,E and K, the water soluble vitamins are the B-complex and C. For the sake of convenience and easy understanding they will be considered in the alphabetical order.

The knowledge of chemical structure, physiological role, deficiency diseases and available source of vitamins is essential in nutritional studies.

## VITAMIN A

Vitamin A, known chemically as **retinol** is an unsaturated monohydric alcohol with the formula  $C_{20}H_{29}OH$ . It is a pale yellow crystalline solid, insoluble in water but soluble in fat solvents. It is readily destroyed by oxidation on exposure to air or light.

In the eye, retinol (Vitamin A) functions in the transmission of light stimuli from the eyes to the brain. The **retinol** combines with the protein to form a visual pigment called **rhodopsin**, by the bleaching of which vision is possible in dim light.

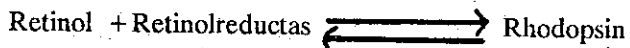

Vitamin A is said to protect the mucous membranes and the structure of developing bones. The deficiency of retinol causes the permanent destruction of cornea (**Keratomalacia**) leading to '**Xerophthalmia**' characterized by drying of the conjunctiva. An early sign of this vitamin deficiency in man is **night blindness** (**Nyctalopia**); followed by premature oldage and greying of hair.

### Sources

Fish liver oils, sun flower oil, ghee, liver, butter milk, eggs, chicken, kidney, carrots, spinach, sweet potatoes, drumstick, green leaves, lettuce, coriander, amaranthus, neem leaves, jack fruits, fig, mango, papaya, tomatoes and oranges.

## VITAMIN B-COMPLEX

The Vitamin B-complex comprises of many Vitamins all grouped together because they are all water soluble and can be obtained from the liver and yeast. Several of these vitamins are essential parts of important enzymes. The recognised nutritionally important B vitamins are discussed below:

### Thiamin (B<sub>1</sub>)

It is a complex nitrogenous base containing a pyrimidin ring joined to a thiazole ring. The main form of thiamin in animal tissues is the diphosphate known as "Thiamin pyrophosphate" which is phosphorylated with ATP. This Vitamin is very soluble in water and has a characteristic odour and 'meaty' flavour. It acts as a coenzyme involved in the oxidative decarboxylation. The deficiency leads to a disease known as **beri-beri** (L.beri = weakness) characterized by partial paralysis associated with **polyneuritis**. Early symptoms of thiamin deficiency include tiresome, loss of appetite and mental disturbance.

### Sources

Unpolished rice, groundnuts, soyabean, mustard, cashewnut, giant chillies, peas, wheat, ragi, cabbage, carrot, eggs, liver, kidney and pork.

### Riboflavin (B<sub>2</sub>)

Riboflavin (Vitamin B<sub>2</sub>) consists of a dimethyl isalloxazine nucleus combined with ribital. It is soluble in water, forming an important constituent of flavoproteins. Its prosthetic group contains riboflavin in the form of phosphate or as flavin adenine dinucleotide (AD) which involves in energy production.

The deficiency of riboflavin results in the characteristic lesions of the lips, sores at the angles of the mouth, dermatitis of face, poor appetite and abnormalities of eyes, anemia, headache, depression, forgetfulness, hair fall and low resistance to infection.

### Sources

Liver, almonds, coconut, soyabean, bengal gram, black gram, jowar, barley, maize, unpolished rice, bran of cereals, ragi, chillies, papaya, cashew fruits, figs, mangoes, milk, liver, and kidney.

### **Nicotinamide**

It is an amide derivative of nicotinic acid (niacin). It is a stable vitamin and is not easily destroyed by heat or oxidation. It functions as the active group of two coenzymes namely nicotinamide-adenine dinucleotide phosphate (NADP), which involve in the energy production through electron transport system.

A deficiency of niacin leads to a disease called pellagra (rough skin) characterized by disorders of skin, digestive and nervous systems.

#### **Sources**

Yeast, liver, groundnuts, meat, fish, kidney, chillies, radish, barley, wheat, peanuts, soyabean and green vegetables.

### **Pyridoxine (B<sub>6</sub>)**

The Vitamin B<sub>6</sub>, pyridoxine is a pyridin derivative exists in three interconvertible forms viz., pyridoxine, pyridoxal and pyridoxamine. Pyridoxal phosphate, an active pyridoxine plays a central role as a coenzyme in the transamination and decarboxylation processes. It also takes part in the absorption of amino acids from the intestine.

A deficiency of this vitamin results in the development of pimples, dermatitis, excessive sweating with oedema, anaemia and nervous convulsions.

#### **Sources**

Wheat, raw husked rice, liver, bengalgram, greengram, redgram, blackgram, soyabean, milk and yeast.

### **Pantothenic acid**

It is a dipeptide derivative. It is a constituent of coenzyme A. This vitamin is bound with adenylic acid, mercapto ethylamine and three phosphates to form coenzyme. It involves in fat and carbohydrate metabolisms.

Deficiency of this vitamin in man results in the retardation of growth, loss of hair, gastro-intestinal disorders, muscular cramps, rheumatoid arthritis and burning sensation in palm and soles.

#### **Sources**

It is widely distributed as its name is derived from a Greek word "pantothén", i.e., from every where indicating its ubiquitous occurrence. Good sources are liver, egg yolk, kidney, fish, milk, yeast, soyabean, peas, mangoes, guava fruits, groundnuts, sweet potatoes, amaranthus, drumsticks, tomatoes and cauliflower.

### **Folacin (Folic acid)**

The word 'Folacin' is used to indicate a number of compounds which are derivatives of folic acid (Monoptero-glutamic acid). It was originally obtained from the leaves of spinach (L. folium = leaf). It involves in the synthesis of choline and serine.

Folic acid deficiency in man results in the impaired erythropoiesis (production of R.B.C) leading to anaemia, retarded growth, loss of appetite, sore mouth, diarrhoea, epilepsy and mental disorders.

### **Biotin**

It is a complex organic compound isolated first in 1936 from egg yolk. It serves as the prosthetic group of several enzymes like acetyl coenzyme A, carboxylase etc., which involve in energy metabolism.

Deficiency of biotin results in the lack of appetite, scaling of skin, fall of hair, and muscular weakness in man.

#### Sources

Eggs, fish, liver, milk, brain, meat, soyabean, wheat, carrot, amaranthus, cabbage, spinach, citrus fruits, watermelon, grapes and tomatoes.

#### Choline

It is a quaternary ammonium base. It is capable of synthesis within the living organism in the form of acetylcholine. This acetylcholine is a potent neurotransmitter helpful in the nerve impulse transmission.

Deficiency of this vitamin leads to fatty cirrhosis of liver, haemorrhagic renal changes, enlarged heart due to high blood pressure and arteriosclerosis.

#### Sources

Liver, brain, kidney, yeast, meat, eggs, fish, cardamon, coriander, cumin seeds, bean, beet root, mushrooms, groundnuts and yeast.

#### VITAMIN B<sub>12</sub>

This vitamin is the cyanide derivative having cobalt and hence it is also known as cyanocobalamine. It plays an important role in the transformation of methylmalonyl coenzyme A to succinyl CoA.

Deficiency of Vitamin B<sub>12</sub> in man causes macrocytic anaemia with lesions of the nervous systems. Its deficiency also results in psoriasis and lack of breast milk.

#### Sources

Liver, kidney, fish, chicken, eggs, milk, butter and cheese.

#### VITAMIN-C

It is chemically called as ascorbic acid and is a water soluble compound. It is a colourless, drystalline acid with reducing properties. It is that stable in acid solution but is readily decomposed in the alkaline medium. It plays an important part in different oxidation-reduction processes as it is a powerful reducing agent.

Deficiency of vitamin C results in anaemia, bleeding gums, bleeding piles, haemorrhage, abortions and leads to a disease called Scurvy characterized by spongy and bleeding gums.

#### Sources

Citrus fruits, Amla, rose petals, rose petals, drumstick's leaves, neem leaves, unripe mango, cashew fruit, kindey, sprouting seeds, corionder and tomato.

#### VITAMIN - D

At least ten different forms of Vitamin D are known existing in the forms of sterols. The two important forms are ergocalciferol (D<sub>2</sub>) and cholecalciferol (D<sub>3</sub>). The D Vitamins are insoluble in water but soluble in fats. The principal action of Vitamin C is to promote the absorption of calcium and phosphorus necessary for growing parts of the bone. When the body is exposed to adequate sun-light with the help of ultraviolet radiation Vitamin D is synthesized in the skin.

The deficiency of Vitamin D in children and young animals results in rickets associated with bowlegs, knockknees and enlarged joints. Child looks old with enlarged head, delayed teething and psoriasis in pregnancy and lactation are also registered due to deficiency of Vitamin D.

#### Sources.

Fish liver oil, fish, egg, liver, butter and milk. This vitamin can also be synthesized on daily exposure to morning and evening sun.

#### VITAMIN-E

The Vitamin E activity of foods is attributed to a series of compounds originating in plants—the tocopherols and the tocotrienols. Eight naturally occurring forms of the Vitamin are known.

Of them four are saturated  $\alpha$ ,  $\beta$ ,  $\gamma$ ,  $\lambda$ , and tocopherols and the other four are unsaturated  $\alpha$ ,  $\beta$ ,  $\gamma$ ,  $\lambda$ , tocopherols. But at present only tocopherol is considered when calculating the Vitamin E content of foods. Vitamin E acts as a biological anti-oxidant. Ketogenesis, lipogenesis and oxidation are influenced by the amount of Vitamin E.

Experiments carried with rats on Vitamin E deficient diet showed that the animals failed to reproduce and hence it is also known as "antisterility Vitamin". Threatened and habitual abortions, dysmenorrhoea (painful bleeding in menses), hypertension and poor lactation are the deficiency symptoms of Vitamin E in man.

#### Sources

Palm oil, soya, cotton seed oil, sweet potatoes, beans, wheat flour, tomatoes, unpolished rice, eggs and butter. Fruits like apples, oranges, and bananas are poor sources of Vitamin E.

#### VITAMIN-K

Originally it was reported that Vitamin K was an essential factor in the prevention of haemorrhagic symptoms and hence a team of

Danish scientist gave the name "Coagulation factor" to the Vitamin which later became shortened to K factor or Vitamin K. It is very necessary for the formation of prothrombin which plays a greater role in blood clotting.

The most naturally occurring compound of Vitamin K is phylloquinone synthesized in green plants. It is a fat soluble vitamin. Deficiency of this Vitamin causes diarrhoea, spruce, liver disorder and jaundice in the new born and uncontrollable haemorrhage in general.

#### Sources

Liver, liver oil, sprouting seeds, spinach, cauliflower, cabbage, eggs, milk and fish meal.

#### HYPERVITAMINOSIS

Pathological condition resulting from an overdose of vitamins is termed as hypervitaminosis. Under natural conditions, it is unlikely that some individuals as well as farm animals will receive excessive doses of vitamins. There is plenty of experimental evidence to show the toxic symptoms of such hyper-vitaminosis in man and other animals. The symptoms include anaemia, emaciation, bone fracture and abnormal growth.

#### WHY DO WE NEED ADDITIONAL VITAMINS?

There will be a greater need for traditional vitamin intake because of the consumption of polished rice, malnutrition, poor consumption of fresh vegetables, and fruits, accelerated use of pesticides and toxic metals in agricultural practice; enhanced stress in daily life; insanitary habits and living conditions inviting a host of infections. Above all, excessive cooking and

roasting will drain a good deal of vitamin content from food. During periods of growth, pregnancy, lactation and infections the vitamin requirement increases.

---

## 28.3 MINERALS

---

Minerals comprise the ash of biological materials remaining after the organic substances have been oxidized. The mineral elements may be classified as essential elements (macronutrients) and trace (micronutrients) elements. There are 7 essential elements; Calcium, phosphorus, Magnesium, Sodium, potassium, Sulphur and Chlorine. They constitute about 70-80% of the inorganic matter in the living body. The trace elements are present in a concentration greater than 1 part in 20,000. They are copper, Zinc, iodine, molybdenum, chromium etc.

### CALCIUM

The Calcium content in blood serum is fairly constant ranging from 9-10 mg/100 ml. It is maintained constant in healthy individuals by parathyroid hormone. It is an important constituent of the skeleton and teeth in which about 99% of the total calcium is found. Calcium is essential for nerve and muscle functions.

#### Deficiency symptoms

Retarded growth rate, Osteoporosis leading to the decalcification of the bone, hyperirritability and tetany leading to death. In adult individuals and animals Calcium deficiency produces Osteomalacia and bones become weak and easily broken.

#### Sources

Legumes, green leafy vegetables, milk, meat, fish meal, bone meal, cereals, citrus molasses, soyabean and peas.

### PHOSPHORUS

It is closely associated with Calcium in the animal body usually within the range of 1:1 to 2:1. The amount of phosphorus present in blood serum is 9 to 12 mg/100ml. It takes part in bone and teeth formation which constitute about 80% of body phosphorus.

#### Deficiency symptoms

Rickets in young ones, Osteomalacia or osteoporosis in adult forms similar to Calcium deficiency. Poor appetite, impaired growth rate, lowered milk and egg production.

#### Sources

Wheat bran, all high protein feeds, bone meal, fish, milk, grains and green vegetables.

### MAGNESIUM

Magnesium is closely associated with calcium and phosphorus as well. About 25g of magnesium is present in adult human body. It acts as an activator of several enzymes, viz., Carboxylase, ATPase, phosphorylase etc.,

#### Deficiency symptoms

Increased nervous irritability, convulsions, muscular weakness and vertigo. Hypomagnesaemic tetany is common in animals (cattle) and man leading to high mortality.

### **Sources**

Wheat bran, barley, dried yeast, cottonseed cake, cloves, cereals, milk, fish, pork, beef and liver.

## **SODIUM**

It is mostly present in the soft tissues and body fluids along with chlorine, carbonates, and bicarbonates. The adult human body contains about 100 g of sodium. It plays a special role in nerve and muscle activity and also regulates acid-base balance.

### **Deficiency symptoms**

Retarded growth, eye lesions and reproductive disturbances in man.

### **Sources**

Meat, eggs, marine fish, seal meat, milk, leafy vegetables, papaya and pine apple.

## **POTASSIUM**

It occurs along with sodium, chlorine and bicarbonate ions. In adult human 250g. of potassium is present. It plays an important part in nerve and muscle excitability.

### **Deficiency symptoms**

General weakness, muscular paralysis, slow growth, stiffness and emaciation. In animals hypertrophy of the heart occurs when fed on potassium deficient diet.

### **Sources**

Barley, maize, raw rice, pulses, leafy vegetables, roots, brinjal, pumpkin, drumstick and tomato; grapes, dates and guava; dairy products, beef, pork, fish are good sources of potassium.

## **SULPHUR**

It occurs in protein containing the amino acids like cystine, cysteine and methionine. Only a small amount of Sulphur is present in the body in inorganic form. It involves in the synthesis of some vitamins and amino acids. Deficiency of this element is not usually considered.

### **Sources**

Liver, Yeast, milk, cereals and green vegetables.

## **CHLORINE**

It is associated with sodium and potassium. Chlorine is excreted from the body in the urine and sweat. It regulates acid-base balance. Its deficiency leads to disrupted nerve and muscle function, gastric troubles, loss of appetite and vomiting.

### **Sources**

Fish, meat and marine animal food.

### **Trace elements**

Trace elements are required in extremely small amounts in the diet and are widely distributed in food stuffs. They play a catalytic role in cellular metabolism.

## **IRON**

About 93% of the iron is combined with proteins like haemoglobin and ferritin. It is also a component of several enzymes like cytochrome and flavoproteins. total iron content of an adult man is about 4-5 gm. It is necessary for haemoglobin formation and certain enzyme reactions. Iron deficiency leads to anaemia, with the symptoms of general fatigue, oedema of ankles, poor growth, and pale skin.

### **Sources**

Green leafy vegetables, legumes, guava, grapes, banana, apple, cereals, jaggery, meat, blood meal, fish and eggs are important sources of iron.

## **Copper**

It occurs in the blood plasma. It involves in various enzyme systems and synthesis of keratin for normal growth and pigmentation of hair. Its deficiency leads to depigmentation, reduced their growth and weakness.

### **Sources**

Barley, raw rice, wheat, bengal gram, green gram, horsegram, coriander leaves, potato, drumstick, banana, milk and liver.

## **COBALT**

Cobalt is an important component of vitamin B<sub>12</sub> hence its deficiency can be cured by injecting this vitamin. Its deficiency causes malnutrition, decreased fertility and poor appetite.

### **Sources**

Leafy vegetables, normal pastures, meat, milk and fruits.

## **IODINE**

Iodine is a major constituent of thyroxine hormone. It involves in the regulation of growth and normal energy metabolism. Its deficiency results in endemic goitre leading to enlargement of thyroid gland, retarded growth and impaired carbohydrate metabolism.

### **Sources**

Crude common salt, marine fish, kale, cabbage, radish, soybeans, linseed, peas and groundnuts.

## **FLUORINE**

It is more concentrated in bones and teeth. The element is very toxic and a level in the diet above 20 mg/kg of dry matter causes a condition known as fluorosis in which teeth become pitted and worn out.

Its requirement is about 1 PPM in drinking water. Fluorine requirement of the body are met by quantity present in drinking water (1-2 PPM) in most regions. Its deficiency causes dental and skeletal fluorosis.

## **ZINC**

It is found in every tissue and tends to accumulate in the bones and hair. It promotes general growth and wound healing. Its deficiency results in poor appetite and skin eruptions.

## Sources

Yeast, green vegetables and sprouting grains.

## MANGANESE

It is present in extremely small amount in bones, liver, kidney and pancreas. It promotes enzyme catalysis, growth and milk production. Its deficiency leads to impaired growth, reduced fertility and abortions.

## Sources

Seed products, yeast, rice bran, wheat and green foods.

## 28.4 NUTRITIONAL REQUIREMENTS AND BALANCED DIETS

Food is the source of fuel which is converted by the metabolic processes of the body into the energy for vital activities. Calorimetry deals with the measurement of nutritive requirement of the body in terms of energy under various physiological conditions.

The nutritive value of foods can be expressed in terms of kilocalories (K.Cal) or mega joules (MJ). The average gross nutritive value of pure carbohydrates, proteins and fats as determined by the bomb calorimeter are given below.

- 1. gm carbohydrates yields 4.1 K.cal
- 1. gm proteins yields 5.65 K.Cal
- 1. gm fats yields 9.45 K.Cal

Energy requirements during work can be calculated by adding together the energy required for 1) basal metabolism 2) additional energy for work and 3) specific dynamic action of food. The requirements are influenced by age, body size, weight, activity, category and climate (Table 28.1).

Table 28.1 Recommended nutrient requirements for different age groups and pregnant and lactating Women ICMR - 1978

Nutrient	Infants	School children	Adolescents	Pregnancy	Lactation
Calories (K.Cal) Kg.	100-120	1800-2100	2500-3000	2.800	3.000
Proteins (g)/Kg.	1.8-2.3	30-40	55-60	55	65
Calcium (g)/Kg.	0.5-0.6	0.4-0.5	0.5-0.7	1.0	1.0
Iron (mg)/Kg.	1 mg.	15-20	20-25	40	30
Vitamin-A (mg)	400	400-600	750-800	750	1150
Thiamin (mg)	0.3	0.9-1.0	1.3-1.5	1.7	0.9
Riboflavin (mg)	0.5	1.0-1.2	1.4-1.7	1.9	2.2
Niacin (mg)	6.0	10-14	18.21	22	25
Vitamin B12	0.2	0.8-1.0	1.0-1.2	1.5	1.5
Ascorbic acid	25	30-50	30-50	50	80
Vitamin D (IU)	200	200	200	200	200

## CONCEPT OF DIETS

The food stuffs have been arranged into four groups each of which make a major contribution to the diet in accordance with the dietary concept.

### 1. Milk group

For children 3 or more 8oz glasses; for teenagers 4 or more glasses, for adults 2 or more glasses of milk. Cheese, ice cream, and other milk products can supply part of the milk recommended.

### 2. Meat group

Two or more servings of meat, fish, poultry eggs, or cheese. Dry beans, peas and nuts are alternatives, although they cannot substitute entirely for meat, fish, or poultry eggs.

### 3. Vegetables and fruits

Four or more servings including some dark green or yellow vegetables, citrus fruits or tomatoes and some raw vegetables.

### 4. Bread and cereals

Four or more servings of enriched or whole grain breads and cereals.

## Balanced Diet

It may be defined as one which contains various food-stuffs like energy yielding foods, body building and protective foods in correct proportions so that an individual is assured of obtaining the minimum requirements of all the nutrients. The components of balanced diet will differ, with age, sex, physical, physiological and economic status.

Balanced diet at high cost will include liberal amounts of costly foods such as milk, eggs, meat, fish and fruits and moderate quantities of cereals, pulses, nuts and fats. Balanced diet at moderate cost will include moderate amounts of cereals, pulses, nuts and green leafy vegetables. Balanced diet at low cost includes small amount of milk, eggs, meat, fish and fats and liberal amounts of cereals, pulses and green leafy vegetables.

## Balanced diet for adolescents

A large number of diet and nutrition surveys have been carried out on the nutritional status of children and adolescents. The results have shown that a majority of the adolescents consume inadequate diets and are malnourished. The main causes are a) inadequate food production b) poverty and c) lack of nutrition education. The balanced diet (ICMR report) for normal adolescents at moderate cost include cereals 420g, pulses 70g, green vegetables 250g, fruits 100g, milk 400ml, meat, fish and eggs 80g, sugar or jagger 30g and peanuts 50g.

Additional nutrients are required for pregnant and lactating women for nourishing the baby. The additional dietary allowances required during pregnancy and lactation are cereals 100g, fruits 50g, milk 300 to 500ml, meat and eggs 40g per day. The balanced diet for school children include additional fruits, milk and eggs to render required energy. In the case of children due to protein caloric malnutrition the disorders like kwashiorkor and marasmus are also reported in the developing countries.

## Check your progress

- I. The deficiency of \_\_\_\_\_ vitamin leads to disease known as beri-beri characterized by partial paralysis associated with polyneuritis.

2. \_\_\_\_\_ mineral plays a special role in nerve and muscle activity and also regulates acid-base balance.

---

### 28.5 SUMMARY

---

1. Water soluble vitamins like B and C and fat soluble vitamins such as A, D, E and K are the potent organic compounds essential for normal health and growth.
2. Major elements like Calcium, Phosphorus, Sodium etc., and tracer elements like iron, copper, iodine etc., are involving in different physiological activities.
3. The nutritive requirements for children, adolescents, pregnant and factating women and different based on caloric value and need.

---

### 28.6 CHECK YOUR PROGRESS - MODEL ANSWERS

---

1. Thiamin (B<sub>1</sub>)
2. Sodium

---

### 28.7 MODEL EXAMINATION QUESITONS

---

- I. Answer the following in about 30 lines.**
1. What are Vitamins? Give an account of fat soluble vitamins and their deficiency symptoms.
  2. What are macroelements ? Explain the nutritional importance, soures and deficiency disorders of phosphorus and calcium.
  3. What is balanced diet ? Mention the nutritional requirements and balanced diets for pregnant women.
- II. Answer the following in about 10 lines.**
1. Discuss the importance of Vitamin E and its sources.
  2. Explain the significance of iron in nutrition.
  3. Mention the importance of iodine in the metabolism.
  4. Elucidate the balanced diet for adolescents at moderate cost.

---

# UNIT 29 OSMO REGULATION

---

## Contents

- 29.1 Objectives
- 29.2 Introduction
- 29.3 Permeability of Plasma Membrane to Water
- 29.4 Osmoregulation and Water Balance in Hypotonic Environment.
- 29.5 Water and Salt Balance in terrestrial animals
- 29.6 Ionic Regulation
- 29.7 Summary
- 29.8 Check Your Progress - Model Answers
- 29.9 Model Examination Questions

---

## 29.1 OBJECTIVES

---

This unit is about the osmotic principles, governing osmotic transfers, mechanism of osmoregulation. At the end of this unit you will be able to elucidate

- ionic regulation and
- water balance in animals living in different habitats.

---

## 29.2 INTRODUCTION

---

The universal solvent of living systems is water. Water moves in or out of the cell until the concentration of solute is equalized between the inside and the outside of the cell. Similarly, different ions and molecules are moving across the cell membrane with reference to concentration gradients. There are different processes such as diffusion, osmosis and active transport through which the substances can be transported.

### 1. Diffusion

It is an extremely slow process. However, diffusion across the membranes is of utmost physiological importance. This process is some times, referred to as passive transport to distinguish it from active transport. A crystal of sodium chloride placed in a volume of water dissolves to form a solution of sodium chloride. Ions of sodium and chloride break loose from the crystal and move independently throughout the water until it gets saturated. This movement from higher to lower concentration of solute is called diffusion. Diffusion stops when the distribution throughout the medium is even. Then there is no more net movement of any component of the solution and the system is considered to be in equilibrium

### 2. Osmosis

Osmosis is the diffusion of water or a solvent through a membrane in response to a concentration gradient. Many cell membranes behave like semipermeable and selectively permeable, because they are relatively much more permeable to water (solvent) than to solutes (salts).

The principles governing osmotic transfer, have been studied with artificial, natural and living cell membranes. An osmometer is a device used to measure osmotic pressure. It must have

a semi-permeable membrane which allows solvent (water) but not the solute to pass. Natural Membranes such as peritonium of intestine, epidermal layer of an onion bulb, egg shell membranes can be used to study this osmosis. Artificial membranes like cellophane can be employed.

If osmosis is allowed to proceed, it leads to the development of an actual hydrostatic pressure, the osmotic pressure. The osmotic pressure is directly proportional to the osmotic activity of the solution and is expressed in terms of atmospheres or millimeters of mercury.

---

### 29.3 PERMEABILITY OF PLASMA MEMBRANE TO WATER

---

Cells act as osmometers to the extent that they act as systems attaining equilibrium for water. Experiments indicate that cells are generally highly permeable to water. For example, when a sea urchin egg is placed in sea water diluted with distilled water it swells. Diluted sea water is said to be hypotonic to the sea urchin egg. Swelling continues with dilution until the membrane bursts and cytolysis occurs. When the egg is placed in sea water concentrated by evaporation, it shrinks and the shrinkage increases, as the medium becomes more concentrated. Such a medium is said to be hypertonic to sea urchin egg. The egg in unaltered sea water does not swell or shrink and the sea water is said to be isotonic (Luke, 1948).

Osmosis depends on the difference in the energy contents of the two compartments that are in contact with the semi-permeable membrane. The term osmotic work is also used to refer to the transport of solute across a water-permeable membrane, particularly, when this is active transport in which the transport is by carrier mechanisms (known as pumps).

The cellular membranes such as skin, muscles, and nerves are electrically charged due to electrical potential difference of the two sides and the transport of anions and cations are through active transport or electro-osmosis. Electro-osmosis includes the movement of water and other ions across the charged membrane.

#### The Gibbs-Donnan Equilibrium

At equilibrium, conditions of unequal concentrations of ionic species on the two sides of biological membranes give rise to the often spectacular phenomena of bioelectricity. This situation is seen in nerve impulses and muscular contraction. The situation was first treated by Gibbs Donnan in 1911 and hence the term "Donnan equilibrium". In living cells, many ions like  $\text{Na}^+$ ,  $\text{K}^+$ ,  $\text{Cl}^-$  represent an osmotic imbalance with reference to the inside and to outside. For example in nerve fibres  $\text{Na}^+$  is more concentrated outside than inside under resting condition, thereby, getting the membrane polarized. During impulse transmission an active  $\text{Na}^+$  pump is operating until it reaches the Dorman's equilibrium condition where the membrane gets depolarized to trigger an impulse. Thus, for various physiological activities the Donnan's equilibrium must be reached through an electro-osmotic principle.

#### Osmo regulation and ionic regulation

A variety of mechanisms present the development of osmotic pressures and maintain an adequate internal osmotic concentrations for the various life processes of cells and organisms, the function of these mechanisms is together referred to as osmoregulation. Osmoregulation is not functionally separable from ionic regulation. Salts penetrate living membranes not as molecules but as ions. The anion and cation of a salt penetrate with different velocities. Even if the aqueous environment is isotonic with the internal body fluids, the body fluids usually have a different ionic composition from the external medium. The mechanisms that maintain differences in ionic composition are the matter of ionic regulation.

## Osmotic relations of cells

The living cells appear to behave very much like osmometers, that is, they swell in media of lower osmotic concentrations than that of their interior. Shrinkage is observed in solutions of osmotic concentration higher than that of their interior.

1. In the red blood cells of vertebrates and eggs of marine animals the swelling and shrinking have been studied extensively. In both cases, the environment of cells is isotonic.

The speed with which these cells swell or shrink in hypo and hypertonic media has been taken as an indication of the permeability of the cell membranes to water as shown in fig 29.1.

2. The cells of fresh water plant like *Elodea* are normally turgid with protoplast held firmly against the cell wall. If these plant cells are placed in a concentrated salt solution, they become plasmolyzed (see fig. 29.2) and the protoplast of each is shrunken to a vacuole. If the hypertonic salt solution is replaced by fresh water each cell regains water and becomes turgid. Thus cells plasmolyzed hypertonic solution return to their initial volume through deplasmolysis.

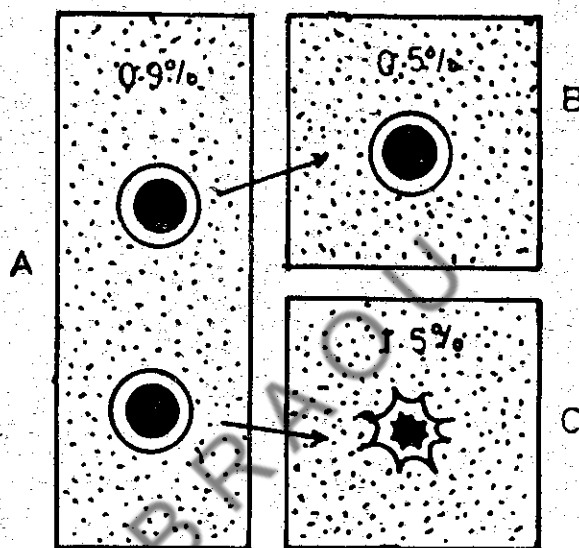

Fig 29.1 Schematic representation of osmotic effects on mammalian red blood cells A) Normal condition of RBC placed in 0.9% NaCl B) placed in hypotonic medium (0.5% NaCl) showing swelling and C) placed in hypertonic medium (1.5% NaCl) showing shrinking.

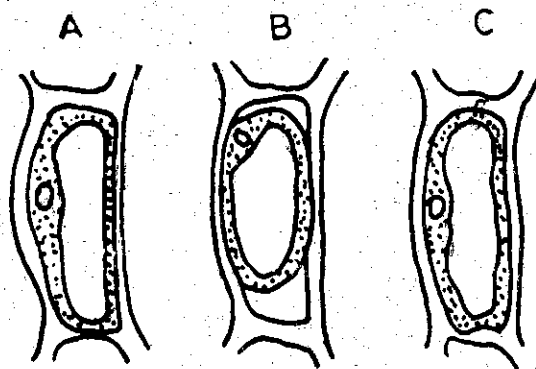

Fig. 29.2 diagrammatic representation of plasmolysis in *Elodea* plant cell exposed to different osmotic concentrations. A) Normal cell B) Plasmolysed cell C) Deplasmolysed cell.

3. In unicellular organism which lives in fresh water the osmoregulation is brought about by two mechanisms: a) formation of a highly impermeable cell wall and b) excretion of excess of water through special contractile vacuules. In the absence of such regulatory devices the cell would soon swell and burst.
4. The body cells of the higher metazoa that live in hypo or hypertonic media are not faced with great osmotic problems because a) only a relatively small number of cells are exposed to the external environment and b) they possess a well-regulated internal medium, (the body fluids) which is isotonic with body cells.

### General terminology

Animals that can withstand aquatic media that have wide range of salt concentrations are called **euryhaline species**. The term includes **anadromous species** which habitually migrate from sea to fresh water river; and **catadromous species** which migrate from fresh water to sea water. The most famous examples of these are the migratory species of eel and salmon.

Animals that survive only within a narrow range of salinities and that are bound to an environment of constant salt content are referred to as **stenohaline**. Stenohaline animals usually do not have osmoregulatory mechanisms.

Aquatic animals whose internal osmotic concentration change with that of the outside environment are called **poikilosmotic** (fig. 29.3) Stenohaline forms are usually poikilosmotic. This property proves fatal whenever the salt concentration of the external sea water changes. in the fig. 29.4 the straight line of spider crab *Maia* shows how the internal and external salinities are always the same, i.e., the crab is **poikilosmotic**. The curved line for shore crab *carcinus* shows how it maintains a high internal osmotic pressure even external medium is lower i.e., it is **homoiosmotic**.

Animals that maintain a more or less constant osmotic concentration of their body fluids despite as difference or changed concentration of the external medium are called **homoiosmosmotic**. Many of the euryhaline species are more or less homoiosmotic. The term "homoiosmotic" implies active osmoregulation.

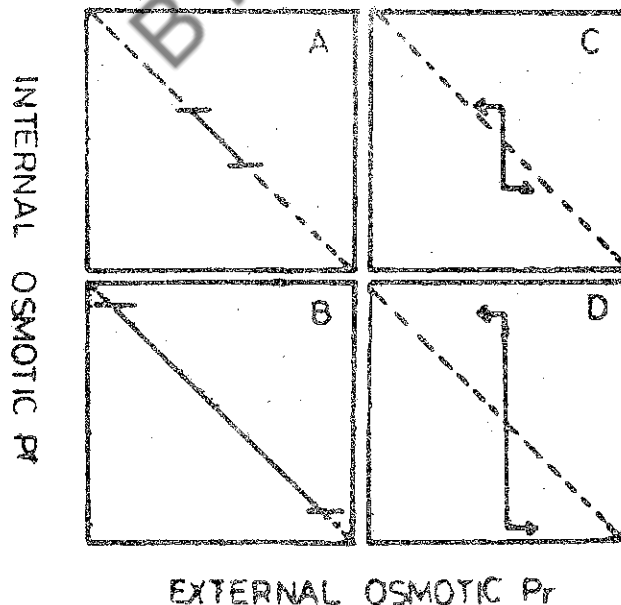

Fig 29.3 Diagrams to explain the terms relation to external and internal osmotic pressures of aquatic animals. A) euryhaline poikilosmotic type B) stenohaline poikilosmotic type C) euryhaline homoiosmotic type and D) stenohaline homoiosmotic type of organism.

Some species regulate their internal osmotic concentration only as long as the external medium is hypotonic. As soon as this medium becomes isotonic and hypertonic, the internal osmotic concentration simply follows that of external medium. In recent years, it has become customary to use the term "hypo-osmotic regulation" (Floncin 1958), when an animal can maintain a hypotonic body fluid, and the term "hyperosmotic regulation" to describe the ability to maintain hypertonic body fluids. Animals that can do one or the other are correspondingly called hypoosmotic regulation and hyperosmotic regulation.

#### 29.4 OSMOREGULATION AND WATER BALANCE IN HYPOTONIC ENVIRONMENT

In fresh water and marine animals whose blood is hypertonic to sea water (sharks, eels, skates and several species of crabs) face the problem of osmotic entry of water and loss of internal salt through filtration. Without protective devices, these animals would either swell or lose so much salt that their internal fluids would not support the normal functioning of the body. The following are the most important devices and mechanisms employed in hyperosmotic regulation.

1. A significant adaptation to life in fresh water is the low internal salt content of the body fluids and body cells.
2. Many fresh water forms have a highly impermeable body walls so that water can enter only slowly. Some forms have an absolutely impermeable body wall and their exchange membranes do not come in contact with water. Examples are aquatic insects, reptiles, birds and mammals.
3. The osmotic entry of water leads to the development of internal hydrostatic pressure as long as the organism stays in hypotonic environment. The consequence of high internal pressures is the production of large volumes of urine. With the loss of urine a volume regulation and salt concentration are achieved.
4. Many fresh water forms have well-developed kidney tubules by which an active reabsorption of salts is achieved. Thus, the excretion of a dilute urine is a special adaptation characteristic

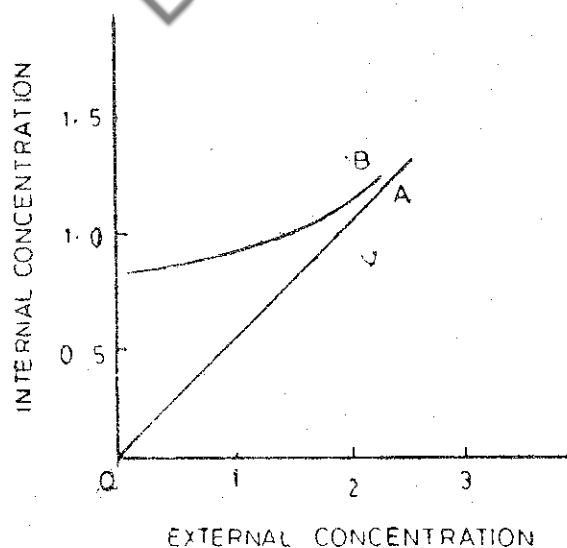

Fig 29.4 Diagram to show the effect of internal and external salt concentrations on two different species of crab A) *Maia* and B) *Carcinuces*.

- of fresh water animals. Examples, Nereis, lamellibranchs, crabs, and teleost fishes. Fresh-water teleost and elasmobranch fishes have nephridia.
- To make up for such loss of salt into the hypotonic medium, euryhaline and fresh-water animals actively absorb and accumulate salts from dilute solutions against concentration gradients. The salt uptake through gills and body surface is very common (Fig. 29.5).
  - The euryhaline but poikilosmotic animals like Sipunculids, Mytilus, Doris, Onchidium etc., take up water or lose water until the body fluids are isotonic or nearly isotonic with external medium. In this case, the animals behave as Osmometers and swell, shrink depending on whether the outside is hypotonic or tonic.

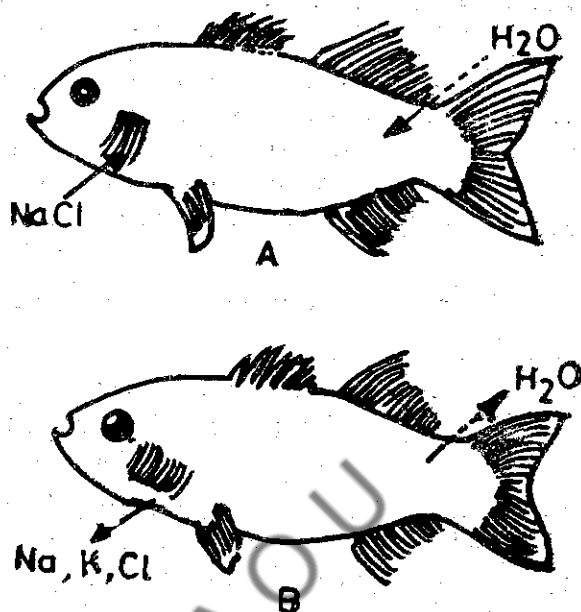

Fig 29.5 Schematic representation of main paths of ion and water movements in osmoregulation of fresh water and A) marine B) teleost fishes.

- Poikilosmotic animals adapt to hypotonic aqueous environment by excreting salt. This lowers the osmotic concentration of the body fluids to make them isotonic with the outside medium. Example: *Aplysia* and some polychaetes.
- An interesting regulator mechanism is found in turbellarians, when the salinity decreases, the worm swells considerably due to formation of large water vacuoles within the cells of the intestine. This is only in part due to excretion of salts.
- Salt conservation in hypotonic media is also aided by the acquisition of salts contained in the food. Internal relative concentration of  $\text{Na}^+$  and  $\text{K}^+$  ions is achieved by selective absorption and excretion.
- The body wall of aquatic animals plays a vital role in osmoregulation due to its mechanical resistance and extension. The osmotic influx of water can proceed only until the internal hydrostatic pressure is equal to the difference of osmotic pressure.

### Osmoregulation and water balance in a hypertonic environment

The animals like marine teleost fishes, cyclostomes, marine crabs, prawns, brine crimps and the larvae of several species of dipteran insects live in a hypertonic aquatic environment exhibit following regulating mechanisms:

- If the body surface and gills are semipermeable that is permeable to water and impermeable to salts, the influx of salt through body surface takes place.

2. Salts accumulate continuously through food uptake. Since pure water is not available, to dilute acquired salts, these animals must conserve water and actively excrete salts.
3. The marine forms swallow sea water and actively excrete salts through gills.
4. The kidneys of marine teleosts produce urine that is hyposmotic to their blood.
5. Teleosts, which migrate from the sea into fresh water rivers (eel and the salmon) stop swallowing water a few hours after entering freshwater. The salmon go so far as to even stop feeding.
6. Almost nothing is known about osmoregulation in migratory cyclostomes
7. the crabs produce urine that is hypertonic to their blood. They achieve osmotic balance by a) taking in hypertonic fluid and b) losing salts more rapidly than water.
8. The brine shrimps can maintain considerably hypotonicity in their body fluids, by drinking sea water and excreting the surplus salts.

---

## 29.5 WATER AND SALT BALANCE IN TERRESTRIAL ANIMALS

---

The problem of water and salt balance in terrestrial organisms closely resemble those of marine forms. Both are surrounded by a medium that contains a lower concentration of water than body fluids. Both obtain salts readily through their food and both must, somehow conserve water and excrete salts. The following are the regulatory mechanisms met within the terrestrial organisms.

1. Terrestrial animals have a body wall that is rather impermeable to water to conserve water. The evaporation of water vapour through respiratory membranes is reduced since the organs of respiration are enclosed within the body.
2. In many homothermic animals the skin possesses sweat glands; which help in water balance, osmo and thermoregulation by producing sweat.
3. The kidneys of terrestrial animals can reabsorb 99% of the water filtered into the tubules. The distal renal tubule actively transport ions into the lumen. The accumulated salt osmotically draws water into the lumen. The amphibian kidney simply stops urine production altogether or reduced to a minimum when the animals stay on land (Reuy, 1965). Urine synthesis is also temporarily reduced in certain mammals like camel and the rabbit.
4. Another water conserving device in insects, birds and mammals is the excretion of relatively dry nitrogenous faecal waste- matter after efficient reabsorption of water.

---

## 29.6 IONIC REGULATION

---

The relative and absolute concentrations of inorganic and organic ions, within body cells differ considerably from those of the body fluids even though the total concentrations of all ions combined are rather similar in both fluid compartments. There are usually two major differences between intra and extra - cellular media.

1. The intracellular medium contains more potassium and less sodium and chloride than the extracellular fluid.
2. the intracellular fluid contains higher concentrations of organic ions in particular of free amino-acids than the extracellular fluid.

## Regulation of inorganic ion concentration

The concentrations of intra- and extra-cellular sodium, potassium, calcium, magnesium and chloride ions of some representative cell types are compared in table 3.1.  $K^+$  and  $Na^+$  ions represent the major amount of intracellular cations. This amount must be equal to that of intracellular anions. However, the electrochemical equilibrium does not explain the proportion of  $K^+$  and  $Na^+$  in the cell.

It is now well-established that the maintenance of unequal concentrations of  $K^+$  and  $Na^+$  ions in cells require the continuous expenditure of energy. Many physiologists have reported the presence of sodium pump which operates against the concentration gradient and against an electrochemical gradient. sodium pump is localized within or just beneath the cell membrane (Hodgkin 1964).

Compound that interferes with oxidative metabolism inhibit the sodium extrusion mechanism. It significantly reactivates the pump even when metabolism remains impaired (Caldwell 1960). The efflux of  $Na^+$  ions appear to be coupled with an influx of  $K^+$  ions.

**Table 29.1 Inorganic ions in the body fluids and in tissue cells of various species (mM/Kg H<sub>2</sub>O or mM/litre)**

Organism	Tissue	Na+	K+	Ca++	Mg++	Cl-
<b>Mollusca</b>						
Anodonta	Serum	15.4	0.38	5.3	0.35	10.5
	Muscle	5.18	10.5	5.9	2.45	10.6
Mytilus	Blood	474.0	12.0	11.09	52.6	553.0
	Muscle	79.0	152.0	7.3	34.0	94.0
Loligo	Blood	456.0	22.2	10.6	54.4	578.0
	Nerve	50.0	400.0	0.4	10.0	40.0
<b>Vertebrata</b>						
Rana	Serum	537.0	9.2	5.87	18.0	542.0
	Muscle	137.0	113.0	2.2	10.8	12.1
Rattus	Serum	150.0	6.4	3.3	16.7	119.0
	Muscle	16.0	152.0	3.5	1.6	5.0

In contrast to the active regulation of the ratio of internal cations,  $Na^+$  and  $K^+$  the inorganic anions  $Cl^-$  and  $HCO_3^-$  (chloride and bicarbonate) passively follow the electrochemical gradients established by the active transport of cations.

## Regulation of Organic Ion Concentration

There is an ample evidence that amino acids are actively transported into cells by specific carrier mechanism. The concentrations of amino acids appear to be regulated whenever one analyses healthy cells of the same kind. But, in crustacean muscle cells, it has been found that the concentration of certain amino acids varies in accordance with the outside osmotic concentration. The precise mechanism by which changes in the external osmotic concentration effect a change in the internal amino acid pool are not known.

## Ionic Regulation of Organisms

In general, that ionic composition of body fluids is similar to that of sea water. In fact, the body of fluids or many marine organisms contain inorganic ions in the same proportion in

which they occur in sea water. Sea water contains far more sodium than any other action. this is followed by magnesium, potassium and calcium. Of the anions, chlorids is the most prominent which is followed by sulphate.

The chloride concentration is some what higher and sulphate is correspondingly lower than that of sea water in coelentrates, arthropods, molluscs, and chordates. Magnesium is concentrated more in some gastropods, cephalopods and bivalves. Potassium ions are more accumulated than in sea water in the body fluids of most molluscs (*Loligo*). The regulation of the specific ionic composition of body fluids depends on a number of mechanisms.

1. The permeability properties of the body wall.
2. The active inward and outward transport of ions in gills and nephrdia (kidneys).
3. Passive transport due to electrical potentials across the membrane.

Active transport across the membrane presupposes an asymmetry of cells that constitute the membrane. For instance, for sodium ions to be carried outward, the 'inner' membranes must carry sodium into the cell while the 'outer' membranes carry it out. A good example of the complexities of transcellular transport is shown in fig. 29.6 which illustrates some of the ion-transport mechanisms of the vertebrate kidney tubules.

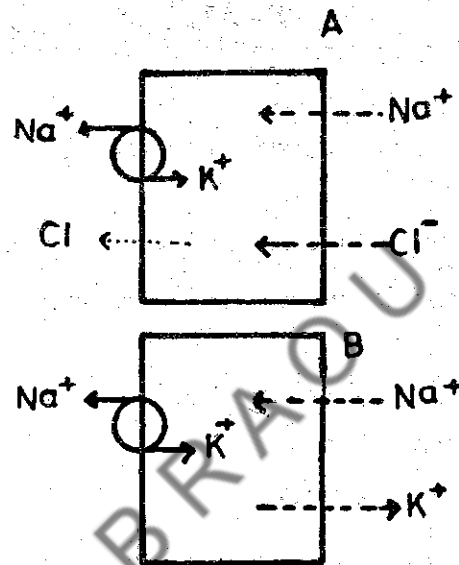

Fig 29.6 Proposed mechanism by which a coupled Na<sup>+</sup> and K<sup>+</sup> pump causes Na<sup>+</sup> reabsorption with associated Cl<sup>-</sup> in the proximal A) and distal B) segments of mammalian kidney tubules.

### Check Your Progress

1. Animals that can withstand aquatic media that have wide range of salt concentrations are called \_\_\_\_\_ Species.
2. Animals that survive only within a narrow range of salinities and that are bound to an environment of constant salt content are referred to as \_\_\_\_\_.
3. Aquatic animals whose internal osmotic concentration change with that of the outside environment are called \_\_\_\_\_.

### 29.7 SUMMARY

1. Atoms and molecules move continuously through various processes such as diffusion, osmosis and active transport.

2. The membranes are selectively permeable and semi-permeable to certain solutes.
3. A variety of mechanisms maintain an adequate internal osmotic concentration for various life processes of organisms collectively referred to as osmoregulation.
4. The mechanisms that maintain differences in ionic composition are known as ionic regulation.
5. Osmoregulation in hypotonic, hypertonic environments and terrestrial animals is discussed with reference to water balance.

---

## 29.8 CHECK YOUR PROGRESS - MODEL ANSWERS

---

1. euryhaline
2. stenohaline
3. poikilosmotic

---

## 29.9 MODEL EXAMINATION QUESTIONS

---

### I. Answer the following in about 30 lines

1. What is osmosis? Explain various mechanisms of osmoregulation in hypotonic medium with examples.
2. Describe the osmoregulation and water balance in terrestrial organisms.
3. Mention different osmotic principles. distinguish between poikilosmotic and homoiosmotic animals.

### II. Answer the following in about 10 lines

1. Cell is an osmometer - Discuss.
2. Distinguish between stenohaline and euryhaline.
3. Mention the devices for inorganic ions regulation found in animals.
4. Describe the significance of ionic regulation in animals.

---

# UNIT - 30 RESPIRATION

---

## Contents

- 30.1 Objectives
- 30.2 Introduction
- 30.3 Respiratory Pigments
- 30.4 Oxygen Transport
- 30.5 Carbon Dioxide Transport
- 30.6 Regulation of Respiration
- 30.7 Summary
- 30.8 Check Your Progress - Model Answers
- 30.9 Model Examination Questions

---

## 30.1 OBJECTIVES

---

The objective of this unit is to explain the mechanism of transportation of respiratory gases involving Bohr effect and chloride shift. At the end of this unit you will be able to describe the

- the role of blood pigments in respiration
- regulation of respiration and respiratory disorders

---

## 30.2 INTRODUCTION

---

You have already studied the basic facts relating to respiration of mammals in your second year course. As you are aware respiration originally stood for taking up oxygen from air and giving off carbon dioxide in exchange. This concept implies that during respiration oxygen is utilized for oxidation of carbohydrates, proteins and lipids to release energy. Respiration, therefore, consists of two phases. The first phase consisting of gaseous exchange between the blood and the environment via the lungs, is referred to as **external respiration**. The second phase consisting of the oxidative energy yielding reactions of the cells is called as **internal respiration**.

Oxygen of the inhaled air diffuses into blood through the walls of the alveoli and the capillaries. Likewise, CO<sub>2</sub> from the blood diffuses into the alveoli. Oxygen is relatively insoluble in plasma (about 0.3ml/100ml). Therefore, only a part of it is carried in solution in plasma; most of the oxygen is transported by **haemoglobin**, a respiratory pigment present in the erythrocytes(RBC). Most of the carbon dioxide on the other hand, is transported by the plasma in the form of soluble bicarbonates. To explain the mechanism of respiration, this lesson discusses the respiratory pigments, transport of respiratory gases, regulation of respiration and common respiratory disorders found in man and other animals.

---

## 30.3 RESPIRATORY PIGMENTS

---

Most animals possess some pigments in their blood which have special affinity to oxygen to increase the oxygen carrying capacity of the blood. Such pigments are called the **respiratory pigments**. These pigments are of four types--haemoglobin, chlorocruorin, haemoerythrin and

haemocyanin. The first two pigments are similar with their molecular structure resembling that of chlorophyll. Haemoglobin is red and chlorocruorin is green. The remaining two pigments unlike haemoglobin, have no "haem" part in their structure, although their names include it.

### Haemoglobin

This pigment is red and occurs most widely among animals. It is a complex compound formed of two separate constituents, the haem and globin. Haem is an iron-containing pigment which is constructed over a porphyrin ring. At the centre of this ring is the ferrous iron, and this ferrous ion is combined with the globin part of the entire haemoglobin(Hb) molecule. Oxygen can loosely combine with this ferrous iron which remain ferrous in both the oxidized and the unoxidized conditions. Each iron atom of the haemoglobin picks up one oxygen molecule. The haemoglobin when combined with oxygen is called the oxyhaemoglobin represented by the formula  $HbO_2$ . Certain other gases combine with Hb to produce a stable compound such as carboxyhaemoglobin through their combination with carbon monoxide, and drain off the oxygen permanently; and whenever this happens the oxygen carrying capacity of the blood is lost and the individual would die. It is for this reason that CO is regarded as a poisonous and fatal gas.

Haemoglobin is found in practically all the vertebrates. The invertebrate haemoglobin is sometimes given a different name as of erythrocrorin. But not all the vertebrates have the same haemoglobin which may be mixtures of two or three types. The differences among them may be due to different globins. Human haemoglobin with a molecular weight 68,000, is bright red when oxygenated and dark red when free of oxygen.

### Properties of Haemoglobin

Since all vertebrates including man carry haemoglobin in their blood, it has, therefore, been the best studied pigment. Human blood contains nearly 150gm haemoglobin per litre and exhibits the following properties.

1. Haemoglobin readily combines with and dissociates from the Oxygen. The iron atom of Hb combines with the one molecule of  $O_2$  to form oxyhaemoglobin.



2. The quantity of  $O_2$  combining with Hb depends upon the pressure of  $O_2$ . The increased pressure results in the increased fixation of oxygen and begins to decline when it reaches close to the saturation point.
3. The Hb and  $O_2$  equilibrium is also greatly influenced by the partial pressure of  $CO_2$ , and with the rise in  $CO_2$  level the frequency of  $HbO_2$  is reduced.
4. The equilibrium between Hb and  $O_2$  also depends on temperature; and with the increase in temperature, the saturation of Hb is lowered.
5. The quantity of electrolytes in plasma also affects the stability of Hb  $O_2$ . If the electrolytes are present at a low  $O_2$  tension, the  $HbO_2$  gives up its  $O_2$  more easily.

### Chlorocruorin

It closely resembles haemoglobin in its structure. The basic difference between them lies in the exchange of one vinyl group for a formyl group in one of the four pyrrole rings that make up the haem molecule. The pigment is green in both the 'oxygenated' and 'reduced' form; the absorption spectra are similar to those of haemoglobin but shifted towards longer wavelengths. The molecular weight is large and is of the order of 3,000,000. It occurs only in polychaete annelids such as serpulidae and sabellidae in colloidal solution in the blood. As in the haemoglobin, one molecule of oxygen combines with each haem.

### Haemoerythrin

It is not a haem-protein, even though the name suggests that it is so (Gr. haem-blood). It is purple when oxygenated and colourless when 'reduced'. It is contained in the cells (Coelomocytes) that circulate with the coelomic fluid. Haemoerythrin is a protein with a molecular weight of the order of 100,000. It is associated with several iron atoms. It is found in sipunculida, and brachiopoda.

### Haemocyanin

It is the characteristic blood pigment of gastropod and cephalopod molluscs, and of crustaceans, arachnids and xiphesura (*Limulus*). It is always present in colloidal solution and is never enclosed in blood cells. Its molecular weight is greater than 1,000,000. Haemocyanin is the only blood protein in the cephalopods. Oxygenated pigment is blue and the 'reduced' pigment is colourless. The protein carries copper atoms that combine with oxygen (one molecule of O<sub>2</sub> per Cu atom)

There are a few more respiratory pigments in addition to these four; for example, the bivalve mollusc *Pinna* contains a brown pinnaglobin, which carries manganese.

---

## 30.4 OXYGEN TRANSPORT

---

Haemoglobin is the principal molecule responsible for transport of both O<sub>2</sub> and CO<sub>2</sub> in the blood. It is the Hb contained within the erythrocytes that accounts for all of the "extra" oxygen content of the blood and significant portion of the "extra" CO<sub>2</sub>. Normally, about 94-98% of the O<sub>2</sub> transported from the lungs to the tissues is carried in reversible combination with the haemoglobin molecule. This may be represented in simple terms by the following equation:

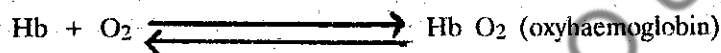

The combination of haemoglobin with oxygen is due to its innate affinity to O<sub>2</sub>. The association of Hb with O<sub>2</sub> is unstable. The degree of association of O<sub>2</sub> with Hb to form Hb O<sub>2</sub> or dissociation of oxyhaemoglobin to release O<sub>2</sub> is determined by the partial pressure of O<sub>2</sub> (P<sub>O2</sub>).

Haemoglobin can combine with gases other than oxygen : for example, it combines reversibly with carbon monoxide

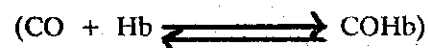

forming carboxyhaemoglobin. Carbonmonoxide is known for its toxic effect and cause what is known as carbon monoxide poisoning, and the person may die of anoxia. It is an essential component of coal gas and exhaust fumes of automobiles. The affinity of Hb to CO is about 300 times higher than that of O<sub>2</sub>.

Four factors, viz., partial pressure of O<sub>2</sub> and CO<sub>2</sub>, temperature and ionic strength influence the equilibrium of haemoglobin-Oxygen, i.e.,  $\text{Hb} + \text{O}_2 \rightleftharpoons \text{Hb O}_2$ .

### 1. PO<sub>2</sub> ——— Oxygen Dissociated Curves

The quantity of oxygen which can be held by Hb depends on the partial pressure of oxygen (P<sub>O2</sub>). The relationship between the two can be graphically represented by a curve called oxygen haemoglobin dissociation curve (Fig 30.1). This curve is sigmoid (S-shaped) in nature, and it envisages the salient features concerning the uptake of dissociation of varying pressures of oxygen. An essential feature of oxyhaemoglobin dissociation curve (commonly referred to as oxygen dissociation curve) is that Hb takes up O<sub>2</sub> when the partial pressure of the latter is high and oxyhaemoglobin (HbO<sub>2</sub>) dissociates when the P<sub>O2</sub> is low.

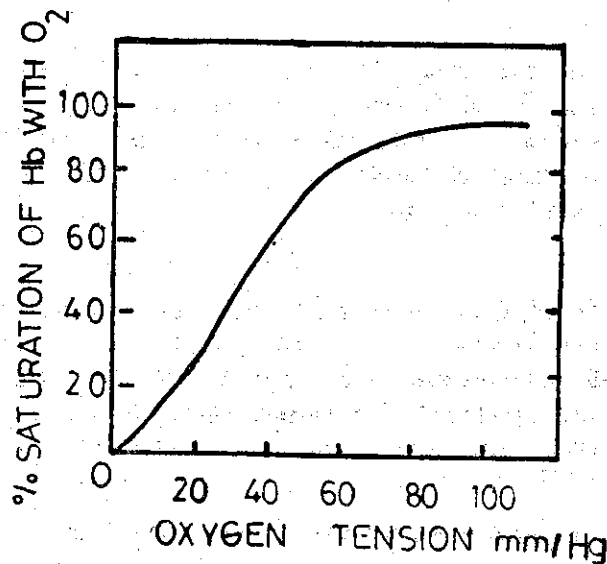

Fig.30.1 Graph showing the relationship between  $P_{O_2}$  and the formation of  $HbO_2$  - "Oxyhaemoglobin - dissociation curve".

The Hb is completely (about 98% saturation) oxygenated by an oxygen tension of 100mm Hg. However, when the  $O_2$  tension falls below 60mm Hg the  $HbO_2$  dissociates rapidly. This is indicated by the steeper slope of the curve at low  $O_2$  tension (Fig. 30.1); when the  $P_{O_2}$  is zero Hb  $O_2$  loses all its  $O_2$ . The Hb gets completely oxygenated in the alveoli of the lungs where the  $O_2$  tension is 100mm Hg and later donates the  $O_2$  to the tissues where the  $O_2$  tension is low and where  $O_2$  is needed most.

When fully saturated each gram of Hb combines with approximately 1.34ml of  $O_2$ . Assuming Hb concentration to be 14.5% g of blood, the total oxygen that could be carried as  $HbO_2$  would be

$$14.5 \times 1.34 = 19.4 \text{ mldr blood.}$$

The oxygen dissociation curve depicted in figure 30.1 is that of normal, average blood, PH 7.4 and  $P_{CO_2}$  40mm Hg at sea level. However, several factors can shift the oxygen dissociation curve to the right or to the left. A shift of the dissociation curve to the right results in greater release of  $O_2$  from  $Hb O_2$  at a given oxygen tension. In other words, a shift to

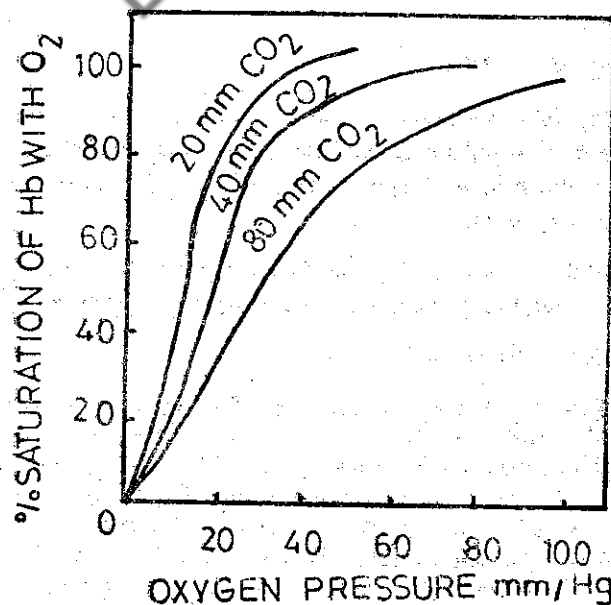
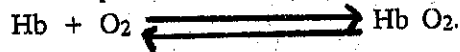

Fig. 30.2 Graph showing the effect of  $PCO_2$  on oxyhaemoglobin-dissociation curve. Note that the curve shifts to the right with the increase in  $PCO_2$ .

the right decreases the affinity of Hb to O<sub>2</sub>. Conversely, a shift to the left increases the affinity of Hb to O<sub>2</sub>; accordingly, it results in a decreased release of O<sub>2</sub> from the Hb at a given O<sub>2</sub>.

## 2. PCO<sub>2</sub> Bohr Effect

Partial pressure of carbon dioxide also determines the equilibrium



The dissociation of oxyhaemoglobin at four different tensions of carbon dioxide has been depicted in fig. 30.2. It shows that oxyhaemoglobin releases O<sub>2</sub> more rapidly at higher concentrations of CO<sub>2</sub>. In effect, this rapid dissociation of Hb O<sub>2</sub> is due to the acidity produced by the CO<sub>2</sub>. Thus a fall in P<sup>H</sup> of blood below 7.4 shifts the oxygen dissociation curve to the right. This is known as the Bohr effect. Bohr effect is of great biological importance. The cells and tissues of the body respiring at a rapid rate have high levels of CO<sub>2</sub>. This causes a rapid release of O<sub>2</sub> in these tissues. Conversely, the uptake of O<sub>2</sub> and the formation of Hb O<sub>2</sub> in the lungs is facilitated by the removal of CO<sub>2</sub> by exhalation.

## 3. Temperature

Like all other chemical reactions the rate of dissociation Hb O<sub>2</sub> into Hb and O<sub>2</sub> increases with the rise of temperature (Fig.30.3).

Thus, an active tissue which has a relatively high PCO<sub>2</sub>, low P<sup>H</sup> and raised temperature sets free more O<sub>2</sub> from Hb for its respiratory process.

## 4. Electrolytes

The electrolyte level in plasma also alters the equilibrium.



At low PO<sub>2</sub> oxyhaemoglobin liberates O<sub>2</sub> more easily in the presence of electrolytes than in their absence. This feat is of great physiological importance to the tissue capillaries where the electrolyte or ionic strength is high and O<sub>2</sub> tension low; and therefore more O<sub>2</sub> is liberated from the HbO<sub>2</sub>.

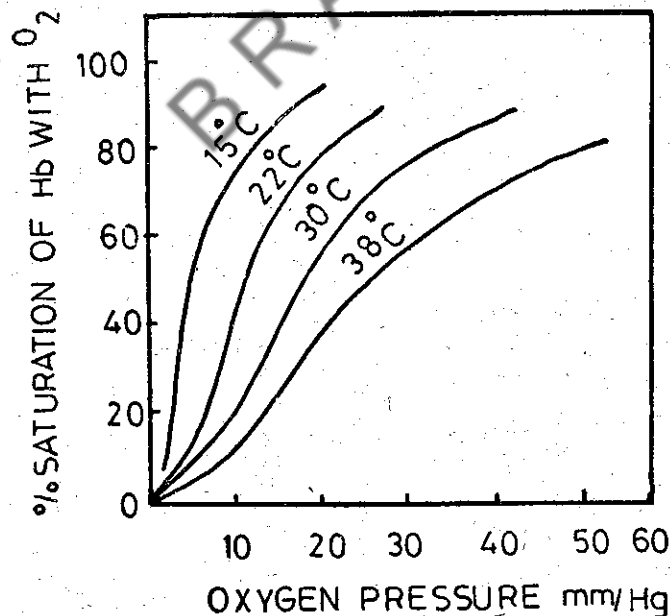

Fig. 30.3 Graph showing the effect of temperature on oxyhaemoglobin-dissociation curve. Note that the curve shift to the right with the increase in temperature.

Yet another factor which influences O<sub>2</sub> dissociation curve is 2,3 diphosphoglycerate (DPG), a metabolic intermediate in Embden-Meyerhof pathway of glycolysis. It stabilizes the

haemoglobin; and therefore, its affinity to oxygen is greatly reduced and HbO<sub>2</sub> rapidly releases O<sub>2</sub> and the oxygen dissociation curve shifts to the right.

Finally, it should be obvious that the amount of O<sub>2</sub> transported in blood will be dependent on the Hb content of blood. This may happen in anaemic persons. One cause of a shift of the oxygen dissociation curve to the left is an increased content of foetal haemoglobin (HbF) in the erythrocytes. An increased affinity to O<sub>2</sub> is a characteristic of HbF, which is advantageous to the foetus.

### 30.5 CARBON DIOXIDE TRANSPORT

Carbon dioxide is transported through the blood in the following ways:

1. A small amount (5%) in the form of simple solution in plasma;
2. A major part (85%) as bicarbonates of sodium and potassium;
3. About 10% in combination with Hb in the form of carbaminohaemoglobin.

#### Chloride Shift

CO<sub>2</sub> reacts with water in the blood to form carbonic acid, although this reaction is very slow in the absence of catalytic activity. It is the enzyme **carbonic anhydrase** present in erythrocytes that catalyses the rapid attainment of equilibrium in the above mentioned reaction. Carbonic acid rapidly and spontaneously dissociates into hydrogen ion and bicarbonate ion because it goes to about 99.9% completion.

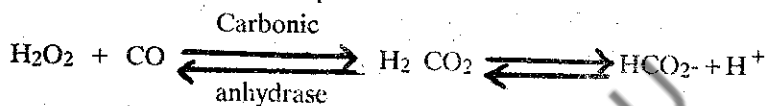

Haemoglobin acts as a buffer in blood that removes the free hydrogen ion from blood to form a protonated haemoglobin, "freeing" an equimolar quantity of bicarbonate ion as depicted in the reaction.

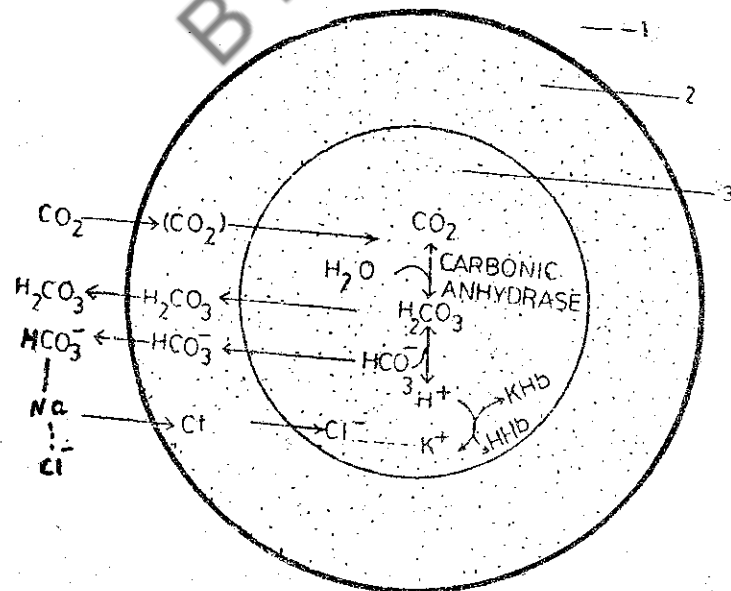

Fig. 30.4 Diagrammatic representation of "the chloride shift" for the transportation of CO<sub>2</sub> in blood.  
1. Plasma 2. Erythrocytic cell wall 3. Interior of erythrocyte.

This reaction, of course, occurs only within the red cell which is highly permeable to potassium ion but even more readily permeable to bicarbonate anion. As the bicarbonate anion diffuses out of the erythrocyte into the plasma, another ion must enter the erythrocyte in equimolar quantities in order to maintain electrical neutrality across the erythrocyte membrane. This is chloride ion, and the exchange between bicarbonate and chloride ions across the erythrocyte membrane is designated as **Chloride shift** (fig 30.4). It accounts for the greater chloride content in venous erythrocytes than in arterial erythrocytes, where the  $\text{CO}_2$  tension is less. The conversion of  $\text{CO}_2$  to bicarbonate ion accounts for about 70% of the  $\text{CO}_2$  transport. When carbonic anhydrase activity is inhibited, such as acetazolamide, the  $\text{CO}_2$  transport from the tissues is inhibited.

In addition to being transported in simple solution and as bicarbonate ion,  $\text{CO}_2$  can combine in a rather loose covalent structure with the alpha-amino groups of the N-terminal valine residues of all 4 chains of the haemoglobin molecule. The carbomino-haemoglobin formed by the interaction of  $\text{CO}_2$  with the amino terminal of the haemoglobin molecule is independent of  $\text{PCO}_2$ . The concentration of  $\text{HbO}_2$  rises when the  $\text{PCO}_2$  is low and when  $\text{PO}_2$  is high. Similarly, the concentration of carbaminohaemoglobin rises when  $\text{PO}_2$  is low and when  $\text{PCO}_2$  is high. This means that saturation of Hb affects its  $\text{CO}_2$  content. This is known as **Haldane effect**. It has a quantitatively greater importance in promoting  $\text{CO}_2$  transport than the Bohr effect has in promoting  $\text{O}_2$  transport.

---

### 30.6 REGULATION OF RESPIRATION

---

The normal rate of respiration in a adult man is 15-18 per minute and the rate and depth of respiration are adjusted to the requirement of the body. There is an efficient mechanism for the regulation of breathing, which may be divided into two parts- a) nervous regulation and b) chemical regulation.

#### 1. Nervous Regulation

A group of nerve cells in the brain stem (Medulla and pons) control the respiratory movements which together constitute the respiratory centre. The respiratory centre consists of four centre, namely (1) Apneustic centre, (2) Pneumotaxic centre, (3) Inspiratory centre and (4) Expiratory centre.

The apneustic centre present in the brain sends impulses simultaneously to the inspiratory centre and the pneumotaxic centre. The inspiratory centre discharges impulses to the respiratory muscles for normal inspiration. This is followed by the stimulation of expiratory centre through the vagus nerve and pre-pneumotaxic centre resulting in rhythmic expiration. Thus rhythmical respiratory activity, which is characteristic of normal respiration, is modulated by the nervous control.

#### 2. Chemical Regulation

The respiratory centre is highly sensitive to alteration in the chemical composition of blood. Changes of  $\text{CO}_2$  tension,  $\text{O}_2$  tension,  $\text{H}^+$  ion concentration alter pulmonary ventilation profoundly. A slight rise of  $\text{CO}_2$  tension increases respiration. During acidosis respiration rises, while during alkalosis it falls. The alteration in  $\text{O}_2$  tension has, however, an insignificant effect on breathing.

#### Respiratory Disorders

Improper aeration of blood due to deranged respiration, if continued for some time in an intact animal, produces a series of pathological manifestations and ultimately death. Some of the common disorders of respiration are the following.

#### 1. Asphyxia

Improper aeration of blood followed by pathological manifestations are collectively called asphyxia. This is due to excess of  $\text{CO}_2$  and each of oxygen and vasoconstriction causes a

systemic rise of blood pressure, convulsions, and the animal opens its mouth widely as if gasping for breath. The animal takes a few gasping breaths at the end and of 4-5 minutes dies.

**2. Hyperpnoea**

It means increased breathing without discomfort. Any rise in the quantity of air breathed per minute is called hyperpnoea.

**3. Dyspnoea**

It means **distressed breathing**. Whenever breathing increases so much as to give a feeling of discomfort, that condition is called dyspnoea.

**4. Orthopnoea**

The patient feels more comfortable in the sitting position than in a prostratic position. This condition is called orthopnoea.

**5. Apnoea**

This means cessation of breathing. Respiration or breathing may be temporarily or permanently stopped.

**6. Anoxia or Hypoxia**

This is a condition in which the take of oxygen in the body leads to anoxaemia.

**Check your progress**

1. Exchange between carbonate and chloride ions across the erythrocyte membrane is designated as \_\_\_\_\_
2. Improper aeration of blood followed by pathological manifestations are collectively called \_\_\_\_\_
3. The patient feels more comfortable in the sitting position than in a prostratic position. This condition is called \_\_\_\_\_

---

**30.7 SUMMARY**

---

1. Respiration involves two phases-external and internal respirations.
2. Respiratory pigments like haemoglobin are involved in the transportation of gases.
3. Oxygen dissociation curves are constructed to show the relationship between partial pressure of O<sub>2</sub> and oxyhaemoglobin.
4. Oxygen displacing effect of CO<sub>2</sub> called **Bohr effect** is verified on the basis of CO<sub>2</sub> tension.
5. CO<sub>2</sub> in the form of bicarbonate is exchanged between chloride-ion through a process called **chloride shift**.
6. The respiratory disorders such as asphyxia, hyperpnoea and dyspnoea are common.

---

**30.8 CHECK YOUR PROGRESS - MODEL ANSWERS**

---

1. Chloride shift
2. asphyxia
3. Orthopnoea

---

### 30.9 MODEL EXAMINATION QUESTIONS

---

**I. Answer the following in about 30 lines each:**

1. Explain how the transportation of respiratory gases takes place.
2. Give an account of respiratory pigments and their importance.
3. Describe the oxygen dissociation curves with suitable diagrammatic illustrations.

**II. Answer the following in about 110 lines each:**

1. Mention the properties of haemoglobin.
2. Explain the chloride shift with an illustration.
3. Show the effect of temperature on oxyhaemoglobin dissociation curves.

BRAOU

---

# UNIT - 31 CIRCULATORY SYSTEM

---

## Contents

- 31.1 Objectives
- 31.2 Introduction to Circulatory System
- 31.3 Blood Coagulation
- 31.4 Factors Involved in Blood Coagulation
- 31.5 Origin, Conduction and Regulation of Heart beat - Cardiac cycle
- 31.6 Summary
- 31.7 Check Your Progress - Model Answers
- 31.8 Model Examination Questions

---

## 31.1 OBJECTIVES

---

This unit deals about the types of blood vessels, modes of circulation, different groups of blood, coagulation and about the heart beat. At the end of this unit you will be able to explain

- The origin, conduction and regulation of heart beat, and
- Cardiac cycle

---

## 31.2 INTRODUCTION TO CIRCULATORY SYSTEM

---

The circulatory system is often termed as the system of internal transport. It is a system in which nutrients and oxygen are carried to all the tissues of the body. It removes the waste products of metabolism, carries hormones from the endocrine glands to their target organs and stabilises body temperatures. It includes the heart, the blood vessels and lymph vessels, in addition to the blood, lymph, cerebrospinal fluid and tissue fluid.

In the very lowest forms of animals like the amoeba and the hydra, there is no transport system and the digested food is absorbed by the tissues directly. In higher forms blood vascular system is developed consisting of elastic pipes and connected with them is a contractile pumping organ, the heart, which keeps the blood in circulation. In certain invertebrates like the crab, cockroach, prawn, scorpion the blood pumped out of the heart leaves the blood vessels and flows into a space or cavity in which lie the organs and tissues. The blood pumped by the heart freely flows between the organs and the tissues and is brought back to the heart (fig.31.1). This type of circulation is called **Open type of blood vascular system**. In vertebrates and higher invertebrates (some forms), the blood returns to the heart after traversing the organs without leaving the blood vessels. This is called **Closed type of circulation** (fig.31.2)

The circulatory system of vertebrates including human beings contain three types of blood vessels - arteries, veins and capillaries. Arteries carry blood from the heart to the tissues of the body. They have an outer coat of connective tissue, a middle coat of smooth muscle cells, and inner coat of endothelium and connective tissue. The outer coat makes the artery resistant to internal pressures while permitting it to expand and contract with each heart beat. The arterial walls are innervated by two sets of nerves one set cause the smooth muscles to contract, the other cause the smooth muscles to relax. With these two action, size of the

arterial lumen is regulated for passage of blood. The aorta is about 25 mm in diameter near the heart and the wall is 3 mm thick, in man.

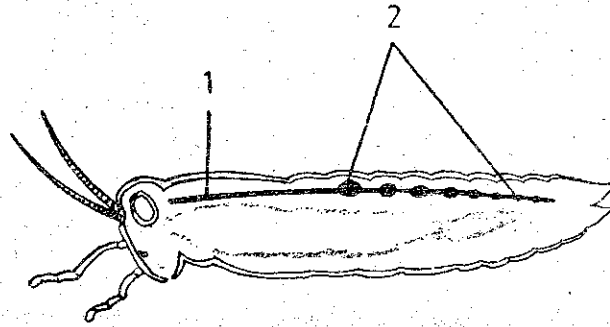

Fig. 31.1 Open type of circulation. 1. Aorta 2. Hearts.

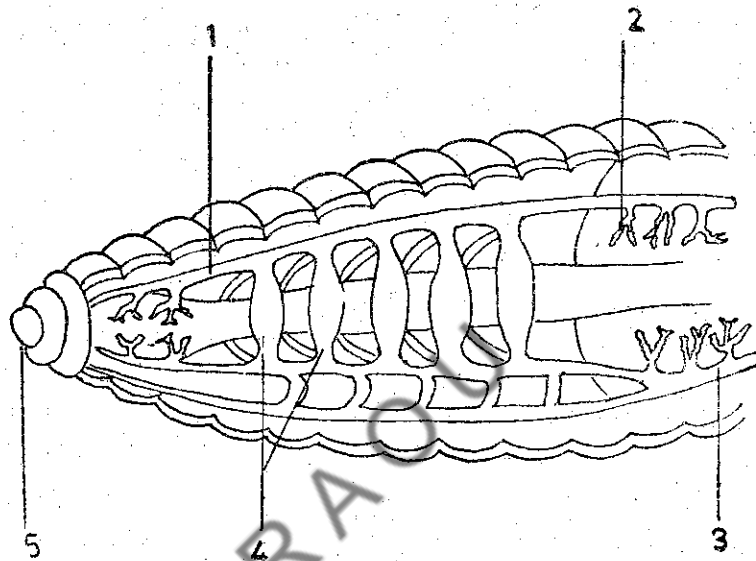

Fig. 31.2 Closed type of circulation 1. Dorsal blood vessel 2. Capillaries 3. Ventral blood vessel 4. Aortic loops 5. Mouth.

Veins return blood from the tissues to the heart. The walls are thin. The outer coat has fewer elastic fibres, the middle thin muscular layer and no internal elastic membrane (most veins). They have valves to prevent the back flow of blood.

Capillaries connect the arteries and veins. They are microscopic, thin walled vessels located in the tissues. Only the walls of the capillaries are thin enough to permit the exchange of nutrients, gases and wastes between blood and tissues. The walls contain single layer of cells the endothelium, continuous with the endothelial lining of the artery and vein on either side. Some of them are so small that the red cells are bent in passing through them. It has been worked out that each cubic centimetre of blood is exposed to 7000 square centimetre of capillary surface. The number of capillaries in muscle tissue is about 2,40,000 per square centimetre. Each capillary bed has certain "thorough fare" channels through which some blood flows continuously from arterioles (smallest arteries) to the veinules (smallest veins). Small muscular precapillary sphincters located at the arteriolar end of capillaries branching off the thorough fare channels open or close other parts of the capillary bed to meet the varying metabolic requirements of the tissue. These sphincters, smooth muscles of the arteries and arterioles regulate the supply of blood to the organs and their parts. Blood flows into capillaries in "spurts" due to contraction and relaxation of muscles in the arterioles and the precapillary

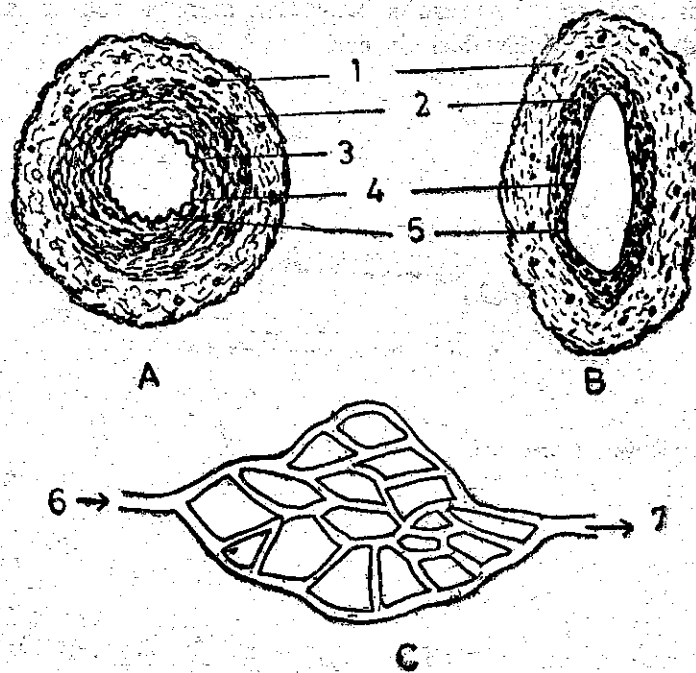

Fig. 31.3 A cross section of an artery. B. Cross section of a vein C. Diagram of a capillary network.  
 1. Outer coat 2. Middle coat 3. Internal elastic membrane 4. Inner coat 5. Endothelium 6. Arteriole  
 7. Venule.

sphincters. This activity is under the nervous control, responding to stimuli, reaching them through the sympathetic nervous system. Local conditions in the tissues control the precapillary sphincters. For example low oxygen tension in the tissue causes the muscles to relax and this increase the flow of blood through the capillary bed and oxygen supply to the tissue is increased.

Blood is the liquid connective tissue. It consists of living cells and is capable of metabolic changes. Its function is to convey materials from one part of the body to another

The volume of blood depends upon body weight, a person weighing 70 kilograms has about 5 litres of blood. It transports nutrients and oxygen to cells and removes wastes from them. It transports hormones. It has a role in regulating the amount of acids, bases, salts and water in cells. It is important in regulating body temperature, cooling organs such as the liver and muscles where an excess of heat is produced and heating the skin where heat loss is greatest. Its white cells are a major defence against bacteria and other disease organisms and its clotting mechanism helps prevent the loss of this valuable fluid.

Blood appears to be a homogeneous crimson fluid but it is composed of a yellowish liquid plasma in which float the red blood corpuscles, white blood corpuscles and blood platelets. The latter are small cell fragments important in initiating the clotting process, that are derived from large cells in the bone marrow. The formed elements make up about 45 percent of whole blood, the remaining 55 percent is plasma. The loss of water when there is heavy sweating will reduce the volume to 50% plasma. When lot of water is taken in, the plasma volume may increased to 60%. The specific gravity of the plasma is 1.03 and of the formed element is 1.09. By centrifuge method the plasma and formed elements can be separated. Blood is always mixed as it is in circulation in the blood vessels with the phenomenon that the blood cells do not separate. The description of blood has been detailed chordate, which you might have been quite familiar.

---

### 31.3 BLOOD COAGULATION

---

Blood whenever it comes out of the vessels, quickly changes from a fluid state into a thick jelly like material, which is known as a clot and the process of separation of clot from the plasma (the serum) is known as coagulation or clotting. Blood drawn from a blood vessel into a test tube changes from a liquid to semisolid gel in about six minutes (roughly 4-10 minutes).

In man and other vertebrates, and in many invertebrates as well, blood loss is prevented by a series of chemical reactions in which a solid clot is formed to plug the broken vessel. Coagulation or clotting is essentially a function of the plasma, not of the blood cells, and involves the enzymatic conversion of **fibrinogen**, a soluble plasma protein, into **fibrin**, an insoluble protein. This process can be separated under following steps:

1. Liberation of thromboplastin.
2. Conversion of prothrombin into thrombin.
3. Conversion of fibrinogen into fibrin.
4. Role of blood platelets.

In the first step thromboplastin arises only at the time of clotting by the combination of certain factors like phospholipid by rupturing of the platelets,  $Ca^{++}$  ions and antihæmophilic factor.

In the second step, in the presence of  $Ca^{++}$  ions the accelerator globulin the prothrombin is converted into thrombin by the thromboplastic activity of thromboplastin.

In the third step proteolytic enzyme thrombin, converts the soluble plasma protein fibrinogen into insoluble protein fibrin, in the presence of cation and the fibrin stabilizing factor. These insoluble fine threads separate from the blood plasma and settle down in the form of a fibrous net.

In the fourth step the blood platelets are presumed to contain thromboplastin. It is released when blood platelets rupture. The rupture of blood platelets occurs when capillaries or blood vessels are damaged and blood flows out. This also liberates a number of other factors which activate the process of clotting or coagulation.

---

### 31.4 FACTORS INVOLVED IN BLOOD COAGULATION

---

1. **Factor I : Fibrinogen** - soluble protein of the plasma. It is converted into fibrin due to enzyme thrombin.
2. **Factor II** : It is a homogeneous protein in the plasma. Prothrombin. It is synthesized in the liver when there is sufficient supply of vitamin 'K'.
3. **Factor III** : Tissue thromboplastin - it is also known as thrombokinase and is obtained from the brain, muscles, lungs or other fixed tissue.
4. **Factor IV**: Calcium ions - These are essential for Coagulation of blood, half of its quantity is in ionised state.
5. **Factor V**: Proaccelerin. It is also called Ac globulin or labile factor. It is found in traces in plasma. It activates prothrombin and makes blood platelets to release thromboplastin.
6. Existence of Factor VI is denied.

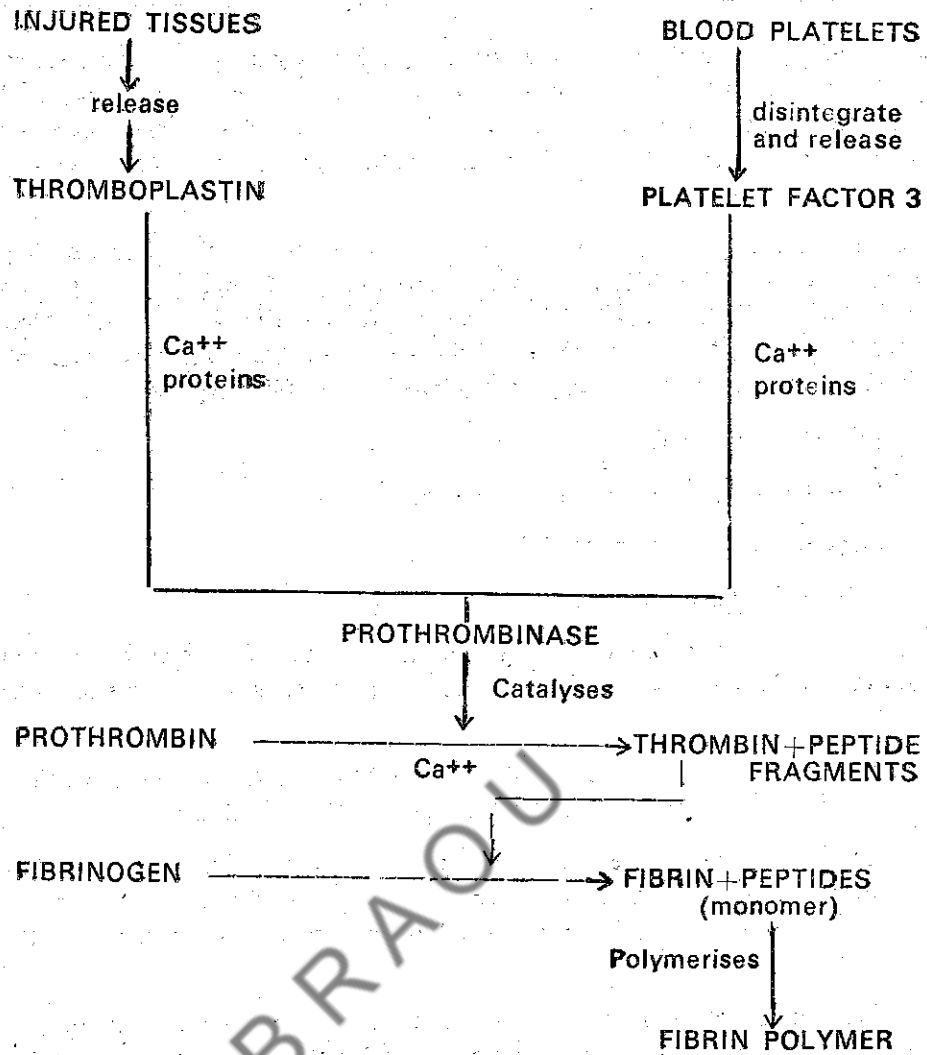

7. **Factor VII:** Proconversion favours the conversion of prothrombin into thrombin. It is also known as proserum prothrombin conversion accelerator.
8. **Factor VIII:** Antihæmophilic globulin or platelet cofactor 1. It helps the release of platelet thromboplastin by accelerating their disruption at the site of damaged tissue. It is absent from serum but present only in the plasma.
9. **Factor IX:** Plasma thromboplastin component or Christmas factor. It is a globulin in inactive stage in the plasma, but is activated by the active thromboplastin antecedent factor (P.T.A). It helps in the formation of tissue thromboplastin.
10. **Factor X Stuart factor:** It is primarily inactive but is activated during coagulation by the presence of Factor VII, VIII and IV.
11. **Factor XI P.T.A.:** It is primarily inactive but is activated at the time of clotting by the presence of Hegeman's factors. It activates factor IX and participates in thromboplastic activity.
12. **Factor XII:** Hegeman factor. It starts action when it comes in contact with some rough surface or the damaged wall of the blood vessel. It activates P.T.A.
13. **Factor XIII:** Fibrin stabilising factor. It helps in the conversion of the soluble fibrin into insoluble fibrin, in the presence of  $\text{Ca}^{++}$  ions.

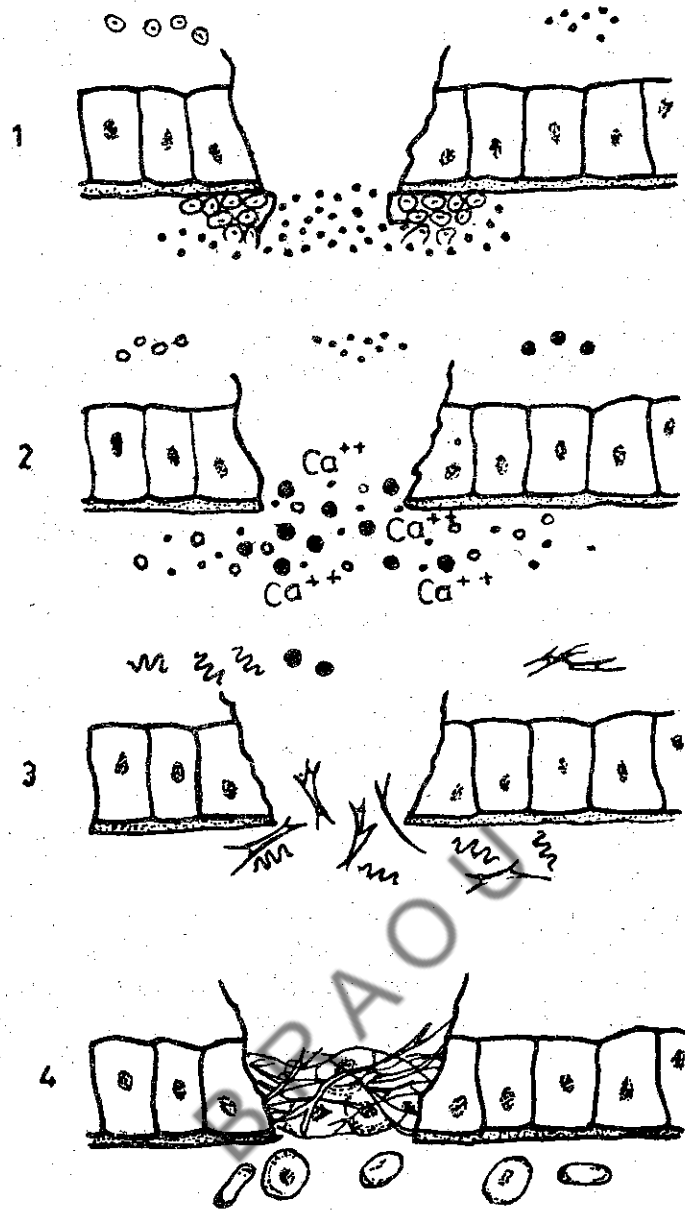

Fig. 31.4 Mechanism of blood clotting:

1 Platelets + Damaged cells  $\xrightarrow[\text{Factors in blood}]{\text{Clotting}}$  Thromboplastin.

2 Prothrombin  $\xrightarrow[\text{Ca}^{++}]{\text{Thromboplastin}}$  Thrombin

3 Fibrinogen  $\xrightarrow{\text{Thrombin}}$  Fibrin

4 Formation of clot.

The importance of coagulation is realised by the study of those cases, where blood fails to clot or it coagulates so slowly as to put them in danger of fatal haemorrhage. This is known as **Bleeder's disease** or **Haemophilia**. It is due to a deficiency of AHF and therefore the platelets do not readily liberate thromboplastin. This disease is often found in males.

The blood contains an inactive enzyme known as prothrombin which is kept in check by another substance in blood called **antiprothrombin** or **heparin**. Thus the blood flowing normally in blood vessels does not coagulate due to the presence of heparin.

The blood that flows during menstruation does not coagulate, either because its fibrinogen has been removed in the uterus or because it has already clotted and the fibrin has subsequently been destroyed by proteolytic enzymes.

**Thrombus** is a condition where the clot adheres to the vessel wall at its site of formation. It is an intravascular clot. An **embolus** is a piece of thrombus which is carried by circulation to some other place to come in another vessel. Roughening of the lining of the blood vessels is supposed to be the reason for intravascular clotting as it liberates thromboplastin. In sufficient thrombin inactivation also may contribute to the process.

### 31.5 ORIGIN, CONDUCTION AND REGULATION OF HEART BEAT-CARDIAC CYCLE

The rhythmic contraction of cardiac muscles is known as **heart beat**. Contraction of the heart is **systole** and relaxation of the heart is **diastole**. This activity takes place in a definite order. The action of the heart takes place in the following states.

**STATE 1.** Simultaneous contraction of both the auricles with the blood passing from the auricles into ventricles which are relaxing.

**STAGE 2.** Simultaneous contraction of ventricles with the result blood is forced into aorta and the pulmonary trunks. Along with it the auricles start relaxing.

**STAGE 3.** In this stage both ventricles and auricles are relaxing. The stage is called the **general pause**. During this stage blood enters the auricles from various vessels.

A continuous and steady supply of oxygen is essential for the cardiac muscle. When the heart works it progressively increases its output upto a critical point. After reaching this point, the output falls but the heart still demands more oxygen and if this is not controlled it may terminate in death. The rate of heart beat increases in case the temperature of the blood is higher. If there is variation of ions of  $Ca^{++}$ ,  $K$ , and bicarbonate the heart beat is seriously affected. If any alteration in the acidity of blood is produced the heart beat rate is affected.

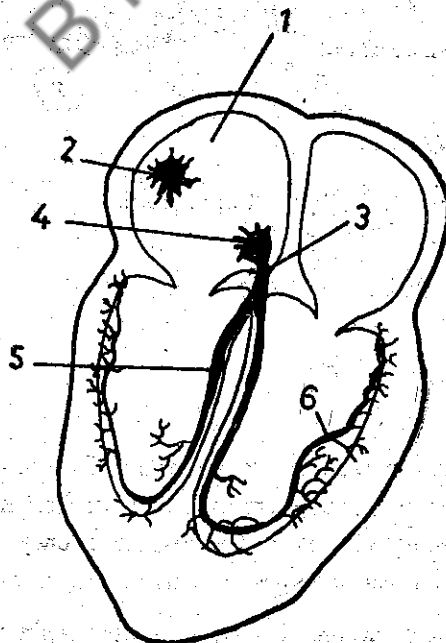
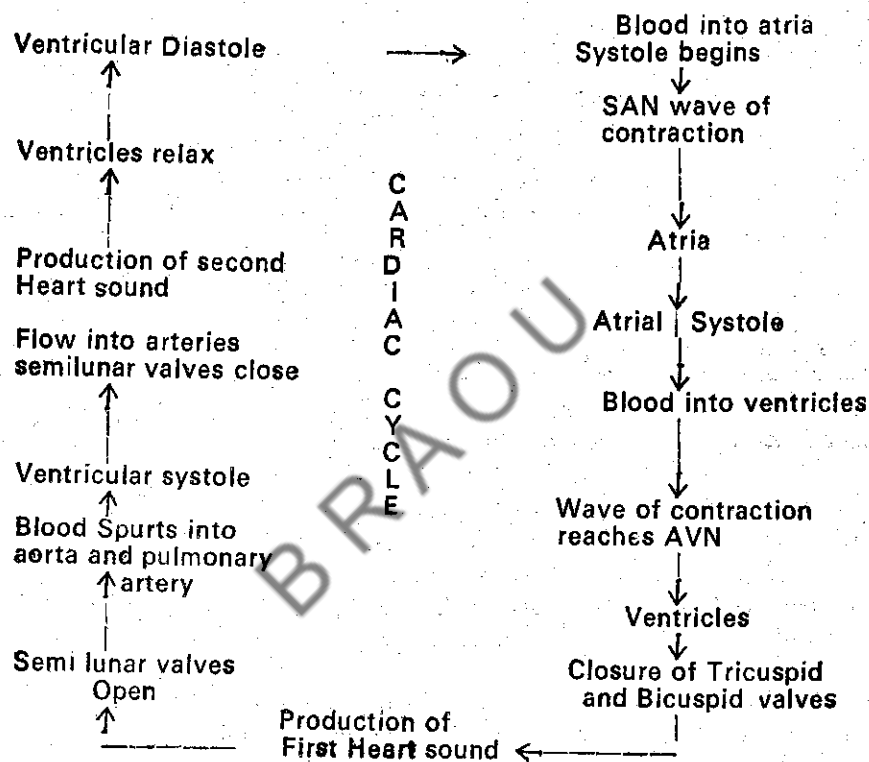

Fig. 31.5. Conduction of contractions of heart. 1. Right atrium. 2. S-A node 3. Bundle of HISA. 4. A-V node 5. Bundle branch 6. Purkinje system.

There is a tiny island of tissues in the upper region of right auricle, where the heart beat originates. It is called the **Sinoauricular node or sinoatrial node (SAN)**. It is believed to be derived from the wall of sinus venosus, located near the opening of large vein. This node acts as a pace maker of the heart. The impulses generated radiate as a wave and make each muscle fibre to contract. Between the two ventricles and just beneath the auriculoventricular septum is found another specialised mass of tissue called as **Auriculo Ventricular Node (AVN)**. The **Bundle of HIS** continues from AVN and Splits into two branches to form the **Purkinje system**. These two branches extend over the two ventricles. The impulse from the SAN contracts the auricles and from the atria it activates AVN and spreads over the ventricles through the Bundle of HIS and Purkinje system.

The complete sequence of events during one complete heart beat is called as **Cardiac Cycle**. The duration of the same is about 0.8 seconds. The duration of ventricular systole and diastole is 0.3 and 0.5 seconds respectively. Action of the heart in pumping of the blood follows a cyclic pattern.



The heart beat is automatic, but is regulated by the centre in the medulla oblongate. This cardiac centre has two parts **cardio-inhibitor** and **cardio-accelerator**. The former sends impulses to SAN by vagus nerve to decrease the heart beat and the latter sends sympathetic nerve to SAN, to accelerate the heart beat. All emotions affect heart beat, and impulses may reach the centre from any part of the body.

Adrenalin and thyroxin influence the heart beat independent of nervous control. Adrenalin acts directly on SAN. Thyroxin increases the oxidative metabolism of body cells and causes rapid contraction of heart.

CO<sub>2</sub> lowers pH of blood and increases the heart beat rate. Acidity accelerates the heart beat but alkalinity retards it. Alkaloids like Muscarin, Atropine and Digitalin increase the force of the heart beat. Histamine produces dangerous fall in blood pressure.

Blood pressure is defined as the pressure that the blood exerts against the walls of its containing vessels. During the peak period of ventricular contraction pressure in the arteries reaches a maximum. This is the **systolic pressure**. During the relaxation of the ventricle, blood pressure falls down. It reaches a minimum just before the beginning of the next systole. This **minimum** is called the **diastolic pressure**. In human being the systolic pressure is about 120 mm Hg. and diastolic pressure about 75 mm Hg. Heart beat rate for a normal person is 72 per minute. Blood pressure is measured by Syhygmomanometer (fig. 31.6).

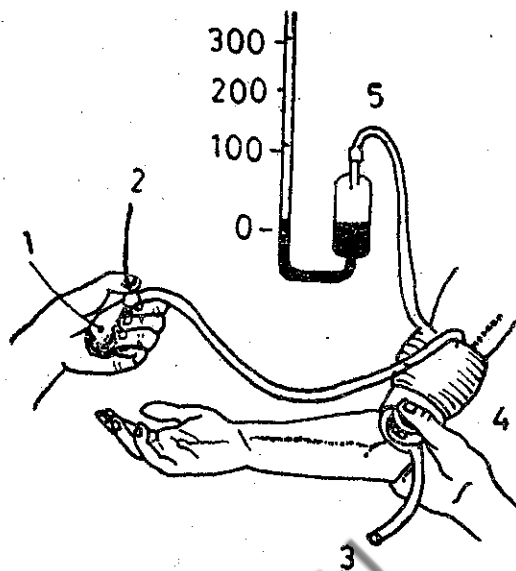

Fig. 31.6 Method of measuring blood pressure in man. 1. Pump 2. Screw for releasing air pressure 3. Stethoscope tube 4. Cuff 5. Manometer.

The beating heart produces characteristic sounds which can be heard by placing the ear against the chest or by using a stethoscope. The first sound which marks the starting ventricular systole, is followed quickly by a second which is highly pitched louder, sharper and shorter in duration marking the end of ventricular systole. The sound is '**Lubb-dub**'. The quality of the sounds indicates the state of valves. When the semilunar valves are injured, a soft hissing noise '**Tub-Shh**' is heard in the place of second sound. Damage to the bicuspid or tricuspid valve affects the quality of the first heart sound.

The amount of blood pumped by the heart is called **cardiac output**. It is about 5 litres per minute at rest and 30 litres per minute during vigorous exercise. Under basal conditions and strenuous exercise following are the sharing percentages of cardiac output.

	Basal conditions	Exercise
Liver	27%	3.3%
Kidney	22%	3.3%
Brain	14%	4.2%
Skeletal muscles	15%	70%

#### Check your progress

- The blood pumped by the heart freely flows between the organs and the tissues and is brought back to the heart. This type of circulation is called \_\_\_\_\_.
- Factor II, Prothrombin is synthesized in the liver when there is sufficient supply of vitamin \_\_\_\_\_.

---

### 31.6 SUMMARY

---

1. Circulatory system is a transport system.
2. There are three types of blood vessels.
3. Several factors help in coagulation of blood
4. Heart beat originates due to wave of contraction.
5. Heart beat is controlled by the nerves and hormones.
6. Blood pressure is defined as the systolic and diastolic components.
7. The patterns of cardiac output are mentioned.

---

### 31.7 CHECK YOUR PROGRESS : MODEL ANSWERS

---

1. Open type of blood vascular system
2. 'K'

---

### 31.8 MODEL EXAMINATION QUESTIONS.

---

- I. Answer the following in about 30 lines each.**
1. Outline the origin and regulation of heart beat.
  2. What are different blood vessels?
  3. How blood coagulates?
- II. Answer the following in about 10 lines each.**
1. Describe an artery.
  2. What are heart sounds?

BRAOU

---

# UNIT 32 NERVOUS SYSTEM

---

## Contents

- 32.1 Objectives
- 32.2 Introduction
- 32.3 What is a Synapses?
- 32.3.1 Types of Synapses
- 32.4 Structures of A Neuro-Neuronal Synapses
- 32.5 Structure of Neuromuscular Junction
- 32.6 Mechanism of Synaptic Transmission
- 32.7 Neurotransmitters
- 32.8 Summary
- 32.9 Check Your Progress - Model Answers
- 32.10 Model Examination Questions.

---

## 32.1 OBJECTIVE

---

This unit is to know the mechanism of transmission of nerve impulse from one nerve cell to another. At the end of this unit you will be able to explain

- different types of synaptic transmissions
- certain chemical substances which act as neurotransmitters

---

## 32.2 INTRODUCTION

---

Having studied about the structure of a nerve cell and about the nature of nerve impulse and nerve impulse transmission across a nerve cell (i.e. axon) it is known that neurones (Nerve cells) conduct information along their axons in the form of impulses. In this unit, you will come to know about the transmission of nerve impulse from one neuron to another neuron and is called **neuro- neuronal transmission**. If the transmission is between the nerve cell and an effector cell (usually muscle fibre) it and is called **neuromuscular transmission**. The transmission of nerve impulse from one neuron to another neuron or one neuron to muscle fibre occurs through a synapse.

The conduction and generation of impulses are confined to a nerve cell, where as communication from cell to cell (nerve cell) is achieved through transmission at specialized regions of the cell called synapse.

---

## 32.3 WHAT IS A SYNAPSE ?

---

The term synapse is coined by **Charles Sherrington(1898)**. Synapse is a small 'gap' present between two neurons. In other words, the junction present between the two neurons is known as a synapse.

A synapse may be defined as 'anatomically demonstratable site, at which one nerve cell(presynaptic neuron) can influence another separate nerve cell(postsynaptic neuron)".

### 32.3.1 Types of Synapses

Basing on their location synapses are of two types:

#### 1. Central Synapses

They occur in central nervous system. In this type the synapse is usually between two nerve cells. There are so many types of central synapses like axo-axonal type (present in giant nerve fibres of earthworm), axo-somatic type (present in cerebellar region of vertebrates, (Fig.32.1) etc.

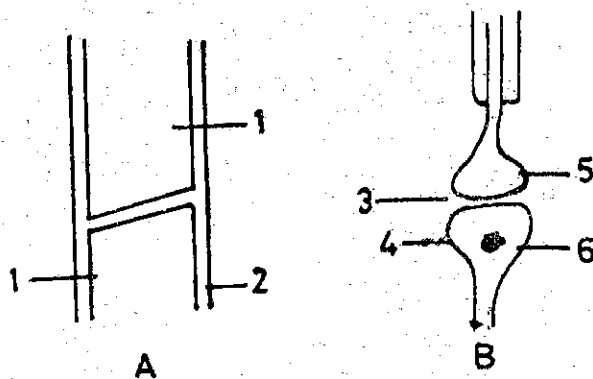

Fig. 32.1 Central synapses: A. Axo-axonal B. Axo-somatic 1. Axon 2. Myelin sheath 3. Synapse 4. Soma 5. Presynaptic neuron 6. Postsynaptic neuron.

#### 2. Peripheral Synapses

They occur at the periphery, mainly with the effector organs.

Eg. Synapse with a muscle fibre (Fig.32.2).

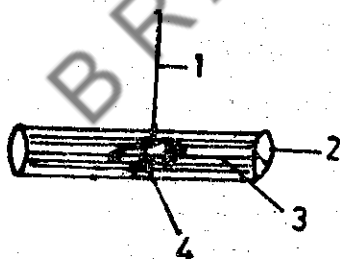

Fig. 32.2 Peripheral synapse-End plate type. 1. Axon(presynaptic) 2. Muscle 3. Muscle fibres 4. End plate.

### 32.4. STRUCTURE OF A NEURO-NEURONAL SYNAPSE

As studied earlier, synapse (Fig. 32.3) is a junction between two nerve-cells. Accordingly the two neurons are called presynaptic neuron and post synaptic neuron. Synapses may be formed between any part of one neuron and any part of another neuron. Detailed structure of a synapse can be studied only under electron microscope. It is clear from the electron microscopic observations that there is no glia at the synaptic region.

The membranes of the two nerve cells are separated by a space called **synaptic cleft**. The width of synaptic cleft varies from  $100 \text{ \AA}$  to  $400 \text{ \AA}$ . In some synapses fine fibrils called

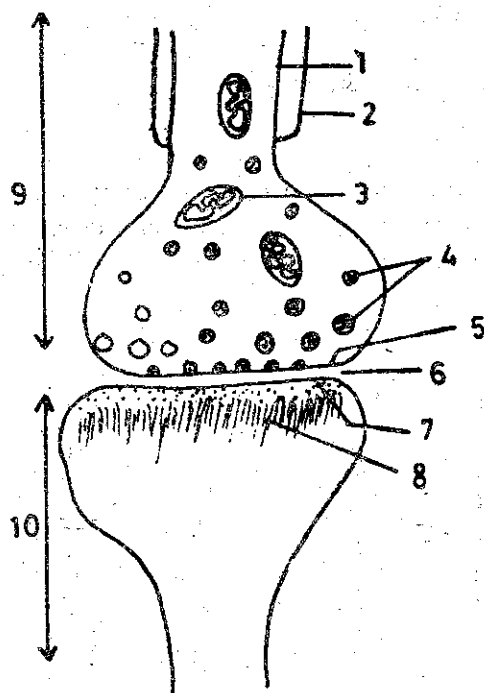

Fig. 32.3 Structure of a synapse (Neuro-neuronal). 1. Axon terminal 2. Myelin sheath 3. Mitochondria 4. Synaptic vesicles 5. Presynaptic membrane 6. Synaptic cleft 7. Postsynaptic membrane 8. Subsynchronous web 9. Presynaptic neuron 10. Postsynaptic neuron.

synaptic filaments are present between pre and postsynaptic membranes. **Subsynchronous web or reticulum** is present underneath the postsynaptic membrane in some vertebrates.

The most important feature that is seen at the presynaptic region is the presence of **synaptic vesicles**. Synaptic vesicles are membrane bounded and contain chemical substance which act as transmitters. During nerve impulse transmission the synaptic vesicles discharge these transmitter substances into the synaptic cleft. Besides the synaptic vesicles, large mitochondria are present at the presynaptic nerve terminal.

### 32.5 STRUCTURE OF NEUROMUSCULAR JUNCTION

Here, the nerve ending makes a junction (Fig 32.4) called the **neuromuscular junction** with the muscle fibre. The nerve fibre, branches and forms branching nerve terminals called **end plates** which invaginate into the muscle fibre, but lies entirely outside the muscle fibre plasma membrane. There is also a space between the nerve terminal and the muscle fibre membrane as in neuro-neuronal synapse. The structure of the synapse in neuromuscular junction is same as that of neuro-neuronal synapse. But in neuromuscular junction the synaptic cleft is thrown into folds which form **secondary synaptic clefts**.

#### Characteristics of a Synapse

Synapses exhibit some characteristic functions. Some of the very important characteristics are as follows:

1. Synapse transmits impulse from one neuron to other or neuron to effector organs (muscle or gland cells).
2. Unidirectional impulse transmission i.e. synapses can transmit impulses only in one direction.
3. The rate of transmission of nerve impulse across a synapse is slow compared to the nerve axon. This is called **synaptic delay**.

## 32.6 MECHANISM OF SYNAPTIC TRANSMISSION

To explain the conduction of impulse along the synapse, two theories have been put forwarded. They are: **Electrical transmission** and **Chemical transmission**. DuBois-Reymond (1877) was the first to suggest the transmission could be either electrical or chemical. But chemically mediated synapses are most frequently seen.

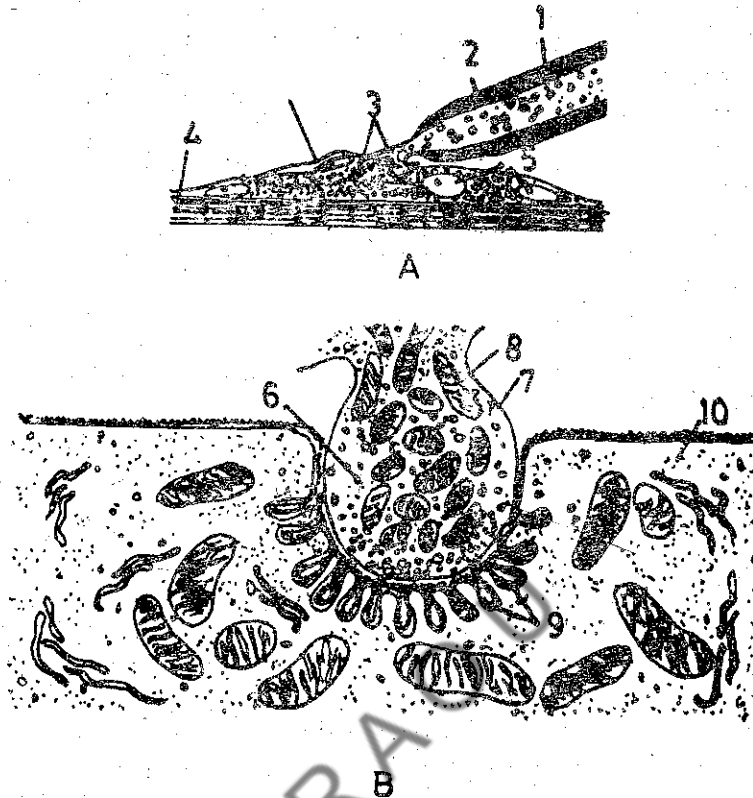

Fig. 32.4 Structure of neuro-muscular junction A. Longitudinal section through the end plate. B. Electron micrographic appearance of the contact point between one of the axon terminals and the muscle fibre membrane. 1. Axon 2. Myelin sheath 3. Terminal nerve branches 4. Myofibrils 5. Muscle nuclei 6. Synaptic vesicles 7. Axon terminal in synaptic trough 8. Mitochondria 9. Subneural clefts.

### I. Electrical Transmission

This type of transmission of nerve impulse occurs in giant synapses of cray fish and in some synapses of mammals. These synapses are called **electrical synapses**. In electrical synapses, the synaptic cleft is very narrow compared to chemical synapses. That means, the pre and post synaptic membranes are in much closer proximity. Hence, the current passes easily from the presynaptic membrane to post synaptic membrane.

The nerve impulse (current) that reaches the post synaptic membrane depolarizes directly and excite the post synaptic neuron. Thus the wave of depolarization or nerve impulse is triggered in the second neuron i.e. post-synaptic neuron.

### II. Chemical Transmission

The works of Elliot (1904), Dixon (1914), Lowry (1921) etc. led to the chemical transmission theory. Majority of the synapses are **chemical synapses**.

According to chemical transmission theory, the nerve impulse conduction across the synapse is mediated by a chemical substance **Transmitter**. The chemical transmitter is synthesized and

stored in the synaptic vesicles at nerve terminal. When the nerve fibre is stimulated, the nerve impulse travels all along the length of the axon and reach presynaptic terminal. Due to the nerve impulse, the chemical transmitter substances stored in the synaptic vesicles at presynaptic nerve ending are liberated into synaptic cleft (Fig. 32.5). These chemical substances then produces a change (depolarization or hyperpolarization) in the postsynaptic membrane thus triggering a nerve impulse in the second neuron. In the case of neuromuscular junction, the chemical transmitter brings about contraction of the muscle fibre.

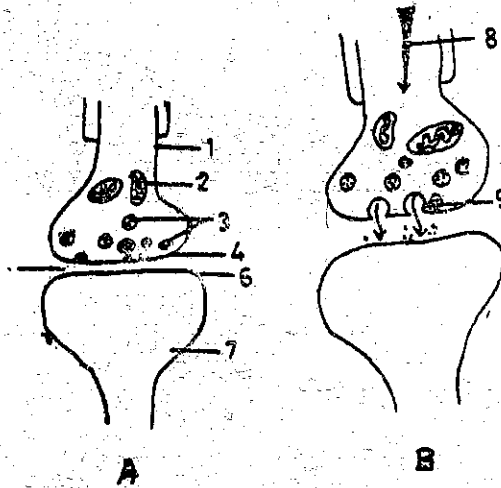
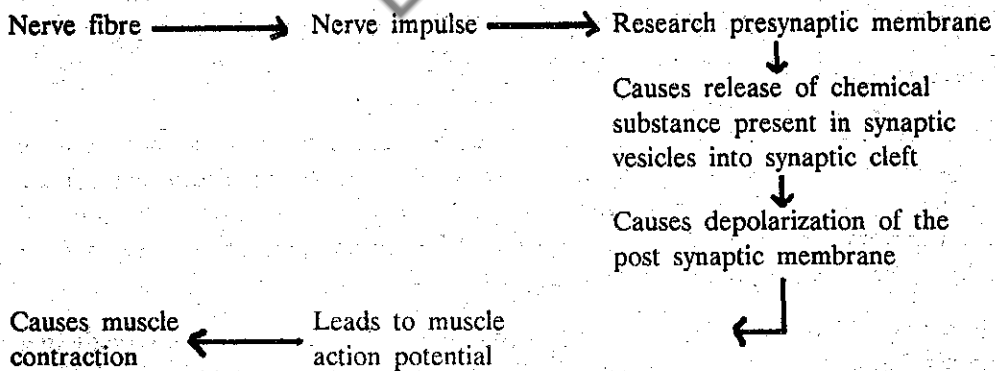

Fig. 32.5 Diagrammatic representation of the release of neurotransmitter into synaptic vesicles. A. Before nerve impulse B. After nerve impulse. 1. Presynaptic nerve ending 2. Mitochondria 3. Synaptic vesicles 4. Presynaptic membrane 5. Synaptic cleft 6. Post synaptic membrane 7. Post synaptic neurone 8. Direction of nerve impulse. 9. Synaptic vesicles releasing chemical substances into synaptic cleft.

Initial work (Dixon, Dale) on chemical transmission indicated that the **acetylcholine** is the chemical transmitter. But later studies confirmed that other chemical substances like noradrenaline, serotonin etc. are also act as chemical transmitters (Neurotransmitters).

#### Schematic representation of chemical transmission across neuromuscular junction



### 32.7 NEUROTRANSMITTERS (Synaptic transmitters)

Many chemical substances act as neurotransmitters. Neurotransmitters help in conduction of information in nervous system. They also bring changes in the effector organs. Some of the important neurotransmitters are as follows:

### 1. Acetylcholine

Most of the synapses have acetylcholine (Ach) as the transmitter substance. Ach is the transmitter substance liberated at the neuromuscular junction of vertebrate skeletal muscle and at some central synapses in a variety of animal groups. Acetylcholine mainly presents at the para sympathetic nerve endings. The nerves that contain Ach at their nerve terminals are called **cholinergic nerves**.

Ach is synthesized in two steps in the nerve cells:

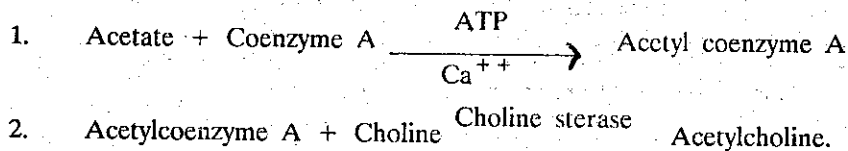

Upon stimulation, the Ach stored in synaptic vesicles at presynaptic nerve endings released into synaptic cleft. The Ach released then causes depolarization in postsynaptic membrane, thus exciting muscle fibre. Ach released into synaptic cleft is quickly hydrolysed by an enzyme acetylcholinesterase.

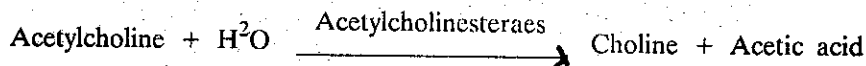

Ach usually has an excitatory effect. It also shows inhibitory effect. For example, when the vagus nerve is stimulated the heart is inhibited. This is due to the release of Ach at Vagus nerve terminal.

### 2. Adrenaline and Noradrenaline

Adrenaline and noradrenaline are also called as **epinephrine** and **norepinephrine** respectively. They together constitute **sympathin**. They are mainly present in the sympathetic nerve endings. Noradrenaline acts as a transmitter at the neuromuscular junctions of mammalian smooth muscle and also at certain central synapses in invertebrates.

Adrenaline and noradrenaline are synthesized from the tyrosine. The neurones employing adrenaline as transmitter are called **Adrenergic nerves**. In most instances noradrenaline cause inhibition, though it is probable that they cause excitation in some areas.

### 3. Dopamine

Dopamine is synthesized from tyrosine.

The effect of dopamine is usually inhibition.

### 4. 5-Hydroxytryptophan

It is also called as **serotonin**. It is almost certainly an excitatory transmitter in the central nervous system of molluscs. It is synthesized from tryptophan.

Certain other amino acids like gamma aminobutyric acid (GABA) and glycine act as excitatory and inhibitory neurotransmitters respectively.

**Check your progress**

Match the following.

- |                                    |     |                     |
|------------------------------------|-----|---------------------|
| 1. Gap present between two neurons | ( ) | a. neurotransmitter |
| 2. Acetyl choline                  | ( ) | b. inhibitor        |
| 3. Dopamine                        | ( ) | c. synapse          |

---

## 32.8 SUMMARY

---

1. Synapse is a functional gap between two neurons.
2. There are central and peripheral synapses.
3. Synapse exhibits some characteristic functions.
4. Synaptic transmission is either electrical or chemical. In chemical transmission, a chemical transmitter mediates the nerve impulse conduction across the synapse.
5. Acetylcholine, adrenaline, noradrenaline, dopamine, serotonin and certain amino acids act as either excitatory or inhibitory neurotransmitters.

---

## 32.9 CHECK YOUR PROGRESS - MODEL ANSWERS

---

1. c.
2. a.
3. b.

---

## 32.10 MODEL EXAMINATION QUESTIONS

---

- I. Answer the following in about 30 lines each:
  1. What is a synapse ? Describe the structure of a synapse.
  2. Describe the structure of neuromuscular junction. Add a note on neurotransmitters.
  3. Describe the theories of synaptic transmission.
- II. Answer the following, about 10 lines each:
  1. Describe the structure of a neuro-neuronal synapse.
  2. Describe the structure of neuro-muscular junction.
  3. Describe briefly the process of chemical transmission.
  4. Write a brief note on neurotransmitters.

---

## Unit – 33 MUSCLE CONTRACTION

---

### Contents

- 33.1 Objectives
- 33.2 Introduction
- 33.3 Structure of Vertebrate Skeletal Muscle
  - 33.3.1 Histological Structure of the Muscle Fibre
- 33.4 Physiology of Contraction
- 33.5 Summary
- 33.6 Check Your Progress
- 33.7 Model Examination Questions.

---

### 33.1 OBJECTIVES

---

The objective of the unit is to know about the muscle contraction in vertebrate animals. At the end of this unit you will be able to describe

- different types of muscles and
- histological structure of muscle fibre
- Physiology of contraction

---

### 33.2 INTRODUCTION

---

#### Different Patterns of Muscle

From the flatworm to the human being all animals have muscles that are similar in their elongate, cylindrical or spindle shape and in their content of contractile protein filaments. The cnidarians have cells that can contract. Most of the invertebrates have only smooth muscles where as arthropods have only striated muscle.

All the movements of higher animals are accomplished through the contraction of muscles; they are the biological molars, that convert chemical energy into mechanical energy and translate the signals from the central nervous system into movements. Muscles consist of large number of elongated cells, usually referred to as muscle fibres. When these fibres are suitably activated they develop tension and shorten.

Muscles are characterised by extraordinary power of contraction on being excited. There are different types of muscular tissues found in vertebrates

#### 1. Skeletal Muscles

They are known as **striated** muscles. Their activities are under **Voluntary** control.

#### 2. Smooth Muscles

These are **nonstriated** found in the wall of visceral organs. They are not under the control of the will of the animal - **Involuntary** muscles.

#### 3. Cardiac muscles

These are striated involuntary muscles, confined to heart only.

The details of the above three types of muscles have been discussed else where.

How does a muscle contract? Physiologists have done work on skeletal muscle to explain this phenomenon. Let us now briefly discuss about the skeletal muscle before we take up muscle contraction.

### 33.3 STRUCTURE OF VERTEBRATE SKELETAL MUSCLE

A typical skeletal muscle of a vertebrate is an elongated mass of tissue consisting of millions of individual muscle fibres. They are bound together by connective tissue fibres. The two ends of a muscle are attached to a two different bones, and its contraction makes one bone to move towards the other and it acts as lever system. The end of the muscle that remains fixed when the muscle contracts is called the **Origin**. The end that moves is called **Insertion**, the thick part in between is the **Belly**.

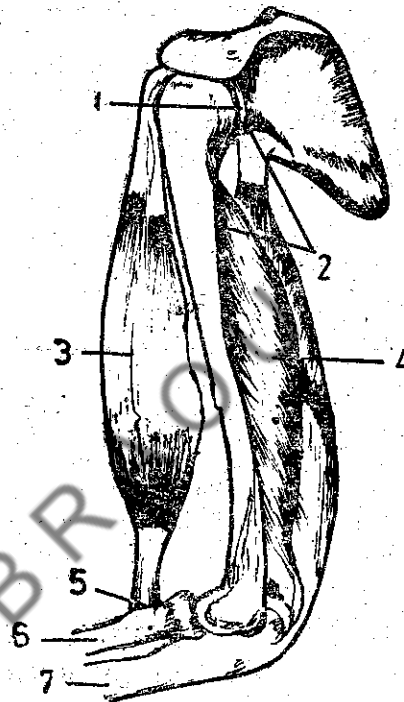

Fig. 33.1 Skeletal muscle. 1. Ball and socket joint 2. Origins 3. Belly of biceps (Flexor) 4. Bell of biceps (Extensor) 5. Insertion 6. Radius 7. Ulna

Units of muscles are the muscle fibres, each of them contain muscle cell, these fibres are in bundles are called **fasciculi**. The connective tissue which covers it is called **perimysium**. The entire muscle bulk is covered by **epimysium**. The space between the muscle fibres is covered by **endomysium**. Under the light microscope the skeletal muscles looked like packed cylinders with transverse bands. The muscle fibre of skeletal tissue are cylindrical and multinucleate.

#### 33.3.1 Histological Structure of the Muscle Fibre

The cell membrane around the muscle fibre is called as **sarcolemma** and cytoplasm inside is called **sarcoplasm**, it is traversed by several long myofibrils which are arranged along the axis of the fibre.

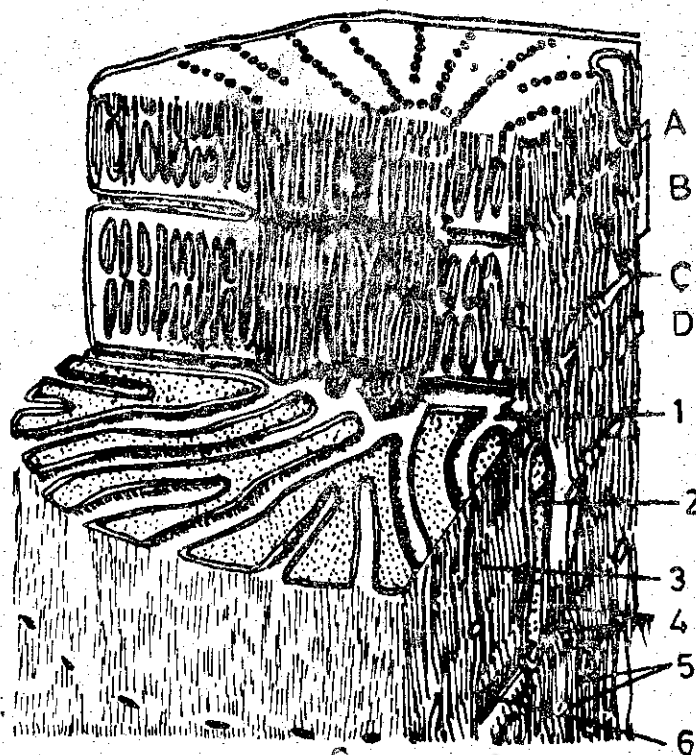

Fig.33.2 Structure of striated muscle fibre. A I band B. A band C. Z line D.H band. 1. T system  
2. Mitochondrion 3. Sarcomere 4. Triad 5. Filaments 6. Myofibril.

Each myofibril is about one  $\mu$  in diameter. It contains light and dark bands. The light bands are non-refractive under polarised light, they are called **isotropic bands**. They are referred to also as I bands. Each 'I' band is bisected at its midpoint by a thin dark line- **Z band** are Kravse' membrane. The portion between two Z-bands is called **sarcomere**.

The dark bands are doubly refractive and are termed as **anisotropic bands**, **A bands** or **Q bands**. Each A band is bisected at the mid point by a thin paler line known as **Hensen's line** or **H-band**. A narrow dark line or **M band** passes through middle of H -band on the lines of **N line** in the mid region of I band. Myosin filaments are thickened at in M Bands.

The ultrastructure of myofibril shows myofilaments, which contains serially repeated segments. Each sarcomere has two types of myofilaments. One is thin myofilament containing actin. Another one is thin myofilaments, are myosin myofilaments containing protein myosin.

The actin filaments are attached to second band at one end and are free at the other. The free ends extend towards H band and inter digitate with myosin filaments. Each actin filament is composed of globular subunit of 'C' actin molecule, arranged in linear fashion forming two longitudinal filaments woven round each other in a helix. Associated with these are found proteins tropomyosin and troponin ( $\text{Ca}^{++}$ -binding protein). Myosin myofilaments extend throughout the length of A bands. They are thicker in the middle and long. They contain myosin protein. Its molecules are tadpole like. Each myosin molecule is differentiated into (1) - light meromyosin (rod like tail) shaft of the myofilament parallel in arrangement, forming a bundle in the axis myofilament. (2) Heavy meromyosin (globular-head) - projecting out from the surface of myosin and corresponds to the cross bridges. It is formed of S1, S2 sub Units. S1 contains Calcium ( $\text{Ca}^{++}$ ) activated ATPase and like sites for binding ATP and actin.

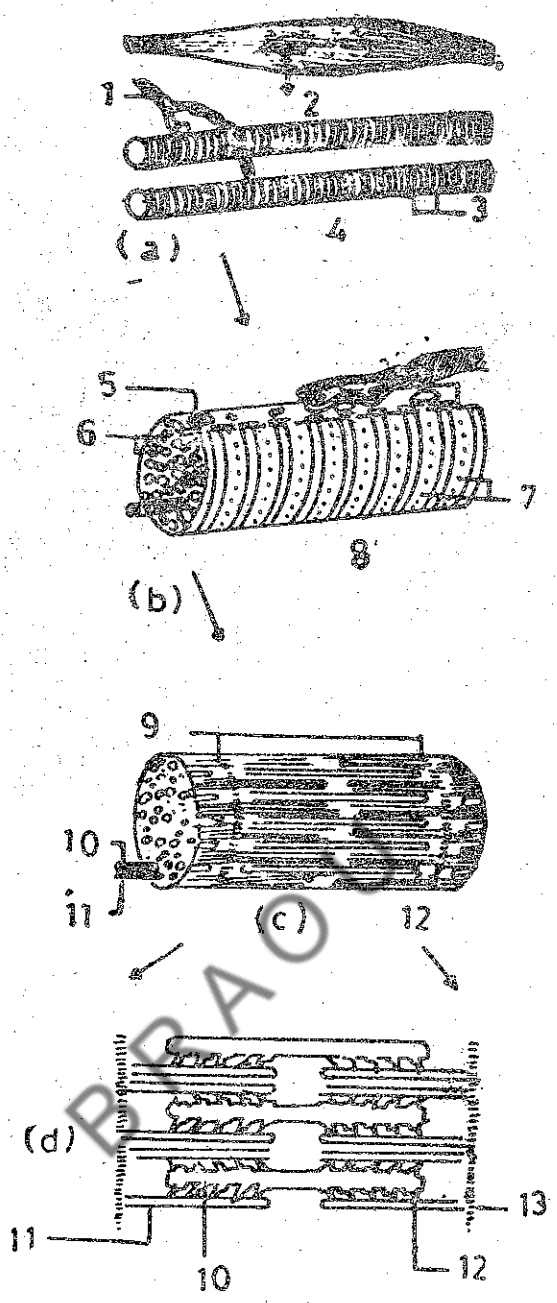

Fig.33.3 Details of muscle fibres 1. Motor neuron 2. Skeletal muscle 3. Striations 4. Muscle fibres 5. Nucleus 6. Myofibrils 7. Opening to T system 8. A single muscle fibre (with portion cut away) 9. Sarcomere 10. Thick filament 11. Thin filament 12. A myofibril 13. Cross bridge 14. Z line

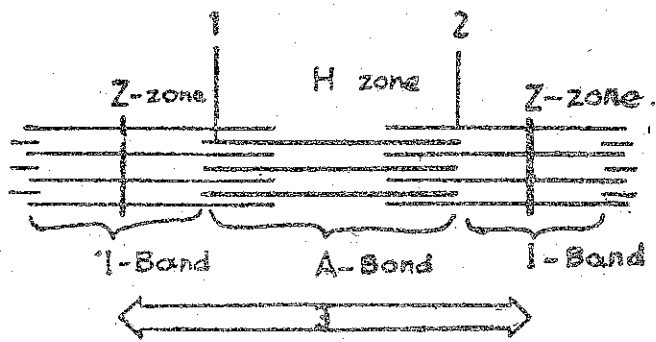

Fig. 33.4 Arrangement of thick and thin filaments. 1. Thick filament 2. Thin filament 3. Sarcomere

The I bands represent those regions of actin filaments which do not overlap with myosin. The H bands, the middle region of A band which are without actin filaments at M band the myosin filaments are interconnected by fine strands.

### 33.4 PHYSIOLOGY OF CONTRACTION

The process of muscle contraction is closely associated with protein filaments of the myofibrils. Sarcomere is the unit of contractility. During contraction the thin actin filaments slide further and further among thick myosin filaments and result in the contraction of sarcomere. This action causes the muscle to shorten in length. During contraction I bands shorten. But the length of 'A' band remains constant.

Hansen and Huxley said that the thin actin filaments slide over with thick myosin filaments among the inner spaces towards centre of sarcomere into the 'A' and 'H' bands. This is brought about by the interaction of cross bridges of myosin with the actin filament. This can be explained in five stages. In the first stage, the cross bridge or S1 meromyosin binds to a globular unit of actin filament. In the second stage the linkage is broken by the energy received from ATP, which dissociates by Ca activated ATPase enzyme of the myosin. In the third stage new linkage is formed between the same meromyosin head (S1) and the next 'G' actin unit. In the fourth stage, due to the repeated making and breaking of linkages between actin and myosin filaments, the actin filaments are pulled towards the centre of sarcomere. In the fifth stage the first bridge returns to the starting configuration in preparation for a new cycle.

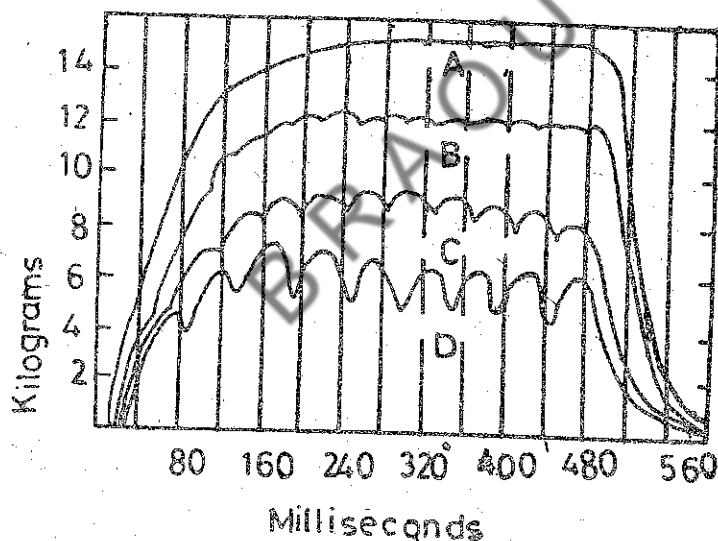

Fig. 33.5 Complete and incomplete tetanus. 1. Kilograms 2. Milliseconds A. 113 per second B. 35 per second C. 23 1/2 per second D. 18 per second

At certain stage of contraction the ends of two adjacent actin filaments may touch each other and I bands will reach the minimum length.

Although the individual muscle fibre is the structural unit of skeletal muscles, it is not the functional unit. All motor neurons leading to the skeletal muscles have branching axons. Each of which terminates in a neuromuscular junction with a single muscle fibre. Nerve impulse passing down a single neuron which thus trigger contraction in all the muscle fibres at which the branches that neuron terminate. This minimum unit of contraction is called the motor unit.

The fibre can be maintained in the contracted state so long as it is stimulated frequently enough. Such sustained contraction is called **tetanus**. Tonus is a mild state of tetanus. It is a state of sustained partial contraction present in all normal skeletal muscles as long as the nerve to the muscles are intact.

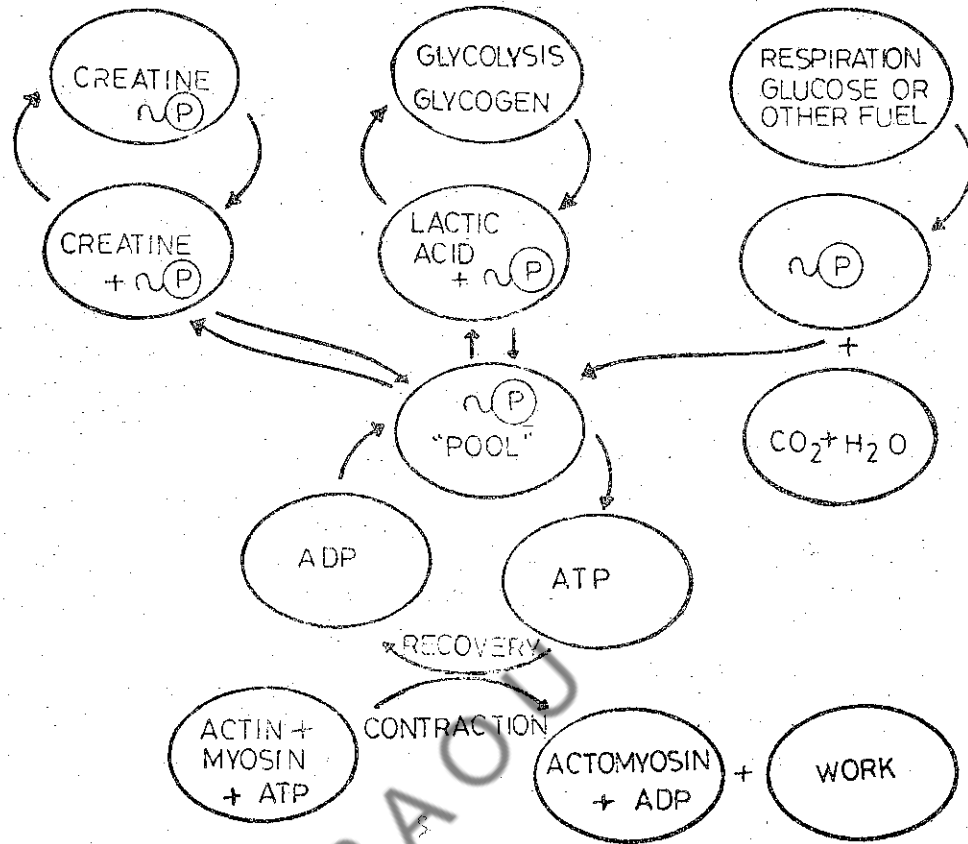

Fig. 33.6 The chemistry of muscle contraction

A muscle that has contracted many times exhausts its stored organic phosphate and glycogen and accumulates lactic acid is called **fatigue**. This phenomenon makes the muscle unable to control any more.

The activity of muscle indicates break down and reconstruction of chemicals, in the presence of catalysing enzymes. In this process potential energy is converted into kinetic energy. The potential energy is from ATP, stored in the myosin filaments. During contraction ATP decomposes into ADP and  $PO_4$  and liberates 12 calories, of energy, which is transferred to the myosin to move the actin. This energy transfer to the muscle is direct. The amount of ATP in the muscle is not sufficient enough to continue contraction. Hence there is need for restoration. Creatin phosphate - energy rich compound also liberates 12 calories, of energy with one  $PO_4$  group. It donates its  $PO_4$  group to ADP to change into ATP. This happens only when the ATP is exhausted. There is 3rd source of energy that is during the process of cell respiration: Conversion of glucose into carbon dioxide and water. The energy liberated by the glycolysis is stored in ADP and creatin which are converted into ATP and creatin phosphate which in turn supply energy for muscle contraction.

#### Cori cycle

When excess of lactic acid accumulates in the muscles due to inadequate supply of oxygen, it diffuses in to the blood. Major part of this blood lactate is then taken up the liver where it is converted into glycogen. The liver glycogen is converted into glucose which enters the

blood and is transported to the muscles. In muscles this glucose is then converted into muscle glycogen. This cycle is called 'Cori Cycle'. Its steps are as follows:

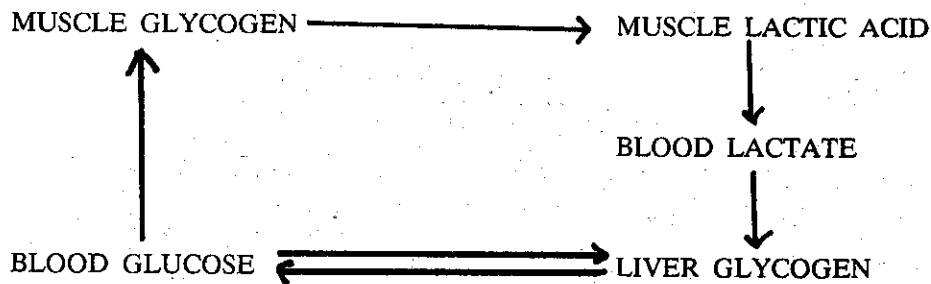

Electric events occur during muscle contraction. Resting potential (-70 mv) is distributed. The potential difference along two surfaces of sarcolemma comes to 0.0 mv (depolarisation). The potential difference reaches to +35 mv which suggests that the inner surface of sarcolemma is positive by 35 mv (reverse polarisation). A potential difference of -70 mv (resting potential) is set in repolarisation. By insertion of micro-electrodes into the muscle fibre, the electrical and mechanical properties have been demonstrated. The main difference is that in muscle the action potential is accompanied by contraction. In other words the electrical energy of action potential is somehow converted into mechanical energy of contraction.

#### ATP Coupling Theory

ATP is very important for muscle contraction. By keeping the muscle block in the glycerin solution, we can make the structural and contractile proteins present in the muscle to get dissolved in the glycerin. At that stage the muscle is unable to contract. The muscle block which is made non-contractile by artificial means is referred as **muscle model**". If this model is kept in the Press Juice of the normal muscle (juice made available by subjecting the normal muscle to different atmospheric pressures) the model contracts. But if the model is kept in Press Juice of decomposed ATP is never contracts. This proves that for the muscle contraction ATP is necessary. Let us briefly discuss the various chemical changes that takes place during muscle contraction.

In the first phase of contraction the terminal cisternae present in Z band release  $Ca^{++}$ . The released  $Ca^{++}$  along with the ADP and in the presence of magnesium makes actomyosin complex. Due to the formation of this complex the inactive ATPase present in active site of the cross bridges present in myosin become activated (fig.33.7 A).

The released active ATPase acts on the  $Mg^{+}$  - ATP complex present in the muscle mass and decomposes the ATP, releasing the energy (fig.33.7 B).

The cross bridges start vibrating by utilizing the released energy. In a muscle block a pair of actin filaments are arranged on either side of the myosin filament. The vibrations of the cross bridges that are bound to one actin filament will be opposite to the vibrations of the cross bridges that are bound to the opposite actin filament. Due to this the actin filament slides over the myosin filament. So that the H band will become narrower (fig.33.7 C).

When once the cross bridges vibrate the actomyosin complex is dissociated and the cross bridges come to their original position. Then in the next phase the cross bridge bind the next active site of the myosin to form actomyosin complex and repeat the vibration cycle (fig. 33.7 D).

Due to repeated sliding movements of the actin filament over the myosin, the muscle block and then the entire muscle filament itself becomes highly contractile. This phase of muscle contraction is referred as **"active state"** of contraction.

After certain period of contraction the "active state" ends and the muscles starts relaxation.

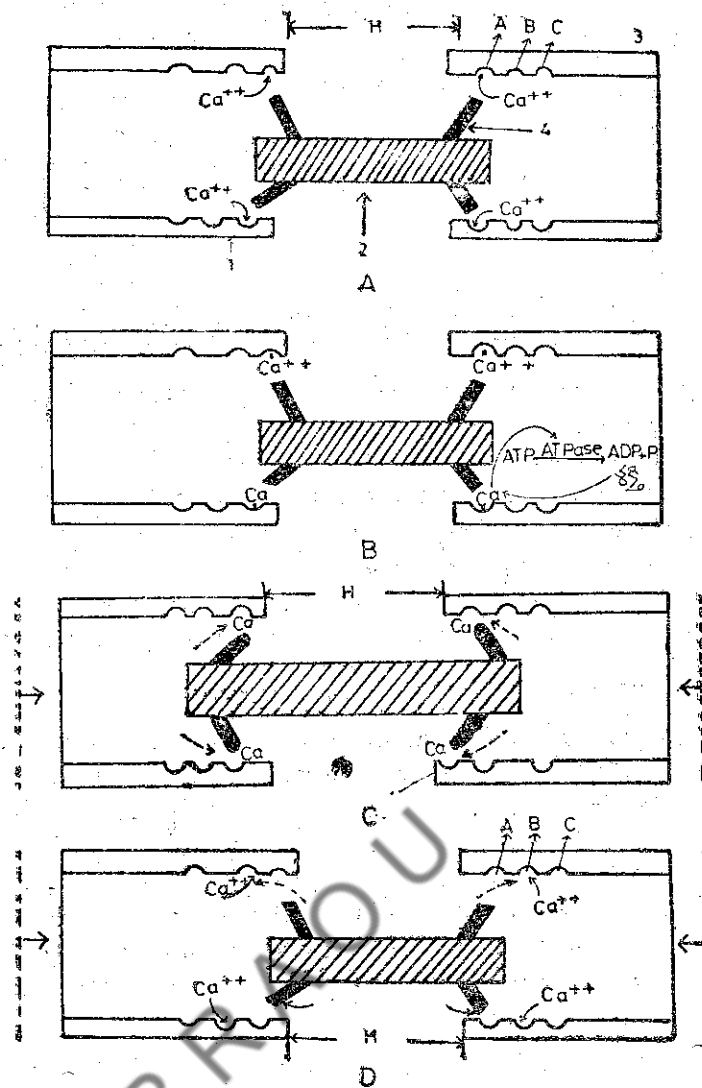

Fig. 33.7 The chemical changes during muscle contraction

### Check Your Progress

1. The liver glycogen is converted into glucose which enters the blood and is transported to the muscles. In muscles this glucose is then converted into muscle glycogen. This cycle is called \_\_\_\_\_.
2. Each 'A' band is bisected at the mid-point by a thin paler line. It is known as \_\_\_\_\_.

### 33.5 SUMMARY

1. Patterns of muscles in vertebrates
2. Structure of skeletal muscle
3. Histology of muscle fibre
4. Physiology of muscle Contraction is explained by a sliding mechanism in which the thin actin filaments are displaced with respect to the thick myosin filaments due to the action of the cross-bridges between these structures.

---

### 33.6 CHECK YOUR PROGRESS - MODEL ANSWERS

---

1. Cori's cycle
2. Hensen's line or H - band

---

### 33.7 MODEL EXAMINATION QUESTIONS

---

**I. Answer the following in about 30 lines:**

1. How a vertebrate muscle contracts?
2. Outline the structures of skeletal muscle?
3. Write briefly about the mechanism of contraction of a muscle laying stress on ATP coupling theory.

**II. Answer the following in about 10 lines.**

1. Describe a myofibril.
2. What is Hansen & Huxley theory?
3. Describe Cori cycle.

BRAOU

---

# UNIT - 34 REPRODUCTION

---

## Contents

- 34.1 Objectives
- 34.2 Introduction
- 34.3 Endocrinological Control of Testicular Functions
- 34.4 Endocrinological Control of Ovarian Functions
- 34.5 Female Reproductive Cycle
- 34.6 Elementary Idea of Implantation, Gestation and Birth
- 34.7 Summary
- 34.8 Check Your Progress - Model Answers
- 34.9 Model Examination Questions

---

## 34.1 OBJECTIVES

---

This unit is to know the mode of reproduction in mammals.

At the end of this unit you will be able to explain:

- the role of endocrines in functioning of testis, ovary
- reproductive cycle of females
- a comprehensive account on implantation and birth.

---

## 34.2 INTRODUCTION

---

Reproduction involves transmission to next generation of genetic material that results in the offspring having the characteristic of species and of an individual within the species. The genetic material is carried to chromosomes in highly specialised cells called gametes. Male gametes are spermatozoa, produced in the testes, and ova in the ovaries. The fusion of spermatozoon with an ovum combines the genetic material from the male and female parents (fig 34.1)

Hormones play an important role in reproduction - due to the secretion of male and female hormones secondary sexual characters, maturation of gonads, rhythmicity of sexual cycle, detachment of the foetus and lactation take place. The details of structure of testes and spermatogenesis has been elucidated elsewhere.

---

## 34.3 ENDOCRINOLOGICAL CONTROL OF TESTICULAR FUNCTIONS

---

The anterior lobe of pituitary gland, in case of the males secretes two hormones 1. **Follicle Stimulating Hormone (FSH)**: It promotes development of seminiferous tubules and maturation of sperms. 2. **Luteinising Hormone (LH)** or Interstitial cells stimulating hormone: it stimulates the activities of interstitial cells and helps in production of testosterone (fig 34.2)

Male sex hormones are **androgens**. It is a collective term including testosterone. 15 - Hydroxytestosterone and 6 - Hydroxytestosterone. Testosterone transforms the boy into a man, that is secondary sexual characters in the male. The release of these hormones is controlled by LH. The out put of FSH is inhibited by a peptide hormone inhibin produced

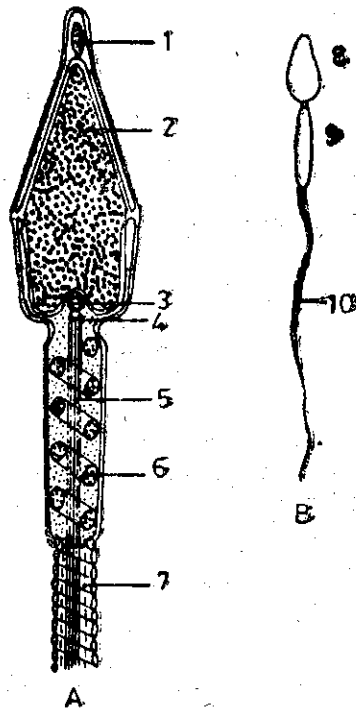

Fig. 34.1 Mammalian sperm A. Under Electron microscope B. Under light microscope 1. Acrosome 2. Nucleus 3. Proximal centriole 4. Distal centriole 5. Axial filament 6. Mitochondrial spiral 7. Thick fiber 8. Head 9. Middle piece 10. Tail

by the sertoli cells. In case, the testes are removed the inhibitory influences are lost. Malnutrition causes a fall in the production of testosterone by inhibiting the production of FSH and LH by the anterior pituitary.

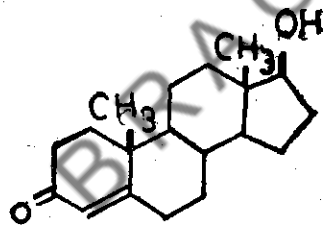

Fig. 34.2 Testosterone

### 34.4 ENDOCRINOLOGICAL CONTROL OF OVARIAN FUNCTIONS

The anterior part of the pituitary gland secretes FSH, which increases the size of the Graffian follicles induces the secretion of estrogens, formation of ovum, and the oestrous cycle. LH which is responsible for maturation of ovarian follicle, secretion of progesterone, stopping the oestrus cycle and implantation of fertilised ovum. The description of the female organs and Oogenesis has been given elsewhere.

Female sex hormones are called estrogens.. These include four steroids - Estrone, and Estradiol, B-estradiol, and Estriol. These are synthesized by the follicles cells of Graffian follicles, the interstitial cells of the ovary and the placenta. Their synthesis is increased by FSH. Estrogens control the menstrual and reproductive cycles, by inducing proliferation of endometrium and increase in secretion of mucus by cervical glands. Contractility and motility of the musculature of fallopian tubes is increased by estrogens. They also control the development of secondary

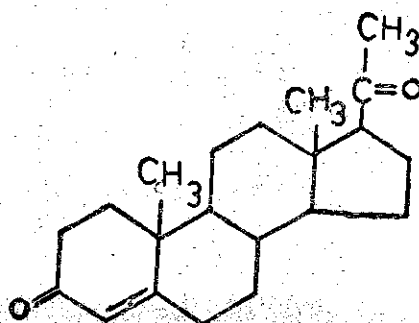

Fig. 34.3 Progesterone

sexual characters. They are lipotropic in nature. They help in the growth of uterus and mammary glands during pregnancy. They act against the progesterone in the uterine mucosa. They have indirect effect on gonads. They stimulate the secretion of adrenocorticotrophic hormone from the anterior pituitary.

The details regarding the functions of testes and ovary of a mammal have also been outlined elsewhere.

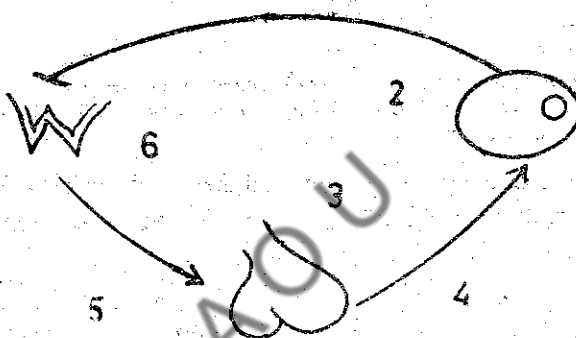

Fig. 34.4 Control Mechanism of female sex hormones. 1. Estrogens 2. Follicle 3. Pituitary gland 4. FSH and LH 5. GnRH 6. Hypothalamus

### 34.5 FEMALE REPRODUCTIVE CYCLE

In all mammals except primates, breeding season is differentiated into one or more oestrous cycles. But in primates it is the menstrual cycle showing the changes in uterine mucosa along with changes in the ovarian follicle. The formation of corpus luteum is immediately after the liberation of ovum. The ovary is stimulated by FSH and with this reaction LH is secreted. Estradiol, a steroid sex hormone stimulates the growth of uterus. The myometrium, and endometrium become thick, vascular and grow in length, stimulating the fallopian tube and vagina. Increase in estradiol inhibits FSH, and stimulates the production of LH. This is the follicular phase.

In the luteal phase lactogenic hormone of the pituitary brings about the rupture of the Graffian follicle, ovulation of ovum and formation of corpus luteum and helps in the production of progesterone. It adds to the effect of estradiol.

If fertilisation of ovum does not occur corpus luteum gradually disintegrates. Level of luteal hormone declines, and the blood along with broken down tissues is discharged from the vagina. This fluid is called menstrual discharge and phenomenon as menstruation.

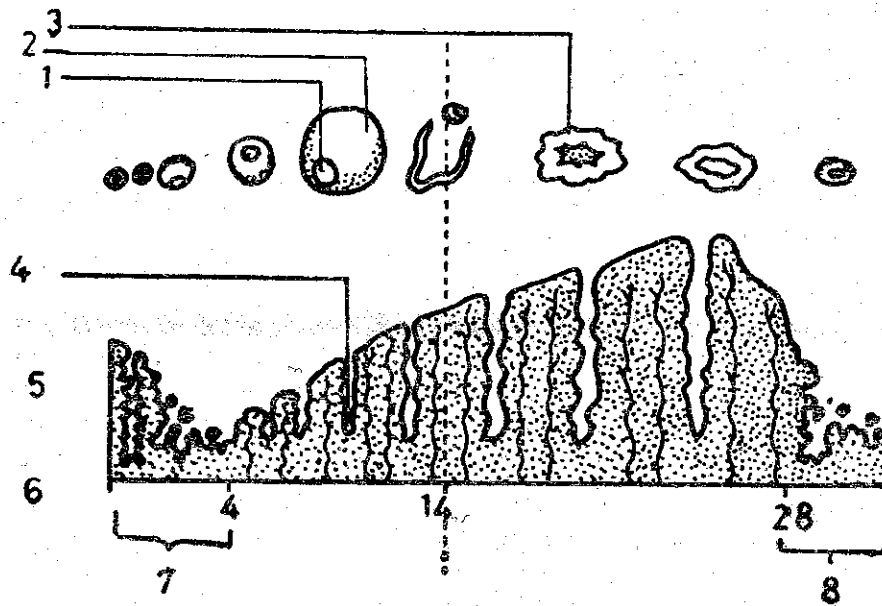

Fig. 34.5 Events occurring in the ovary. 1. Egg. 2. Follicle 3. Corpus luteum 4. Exocrine gland 5. Lining of uterus 6. Days 7 and 8. Menstrual flow.

### 34.6 ELEMENTARY IDEA OF IMPLANTATION, GESTATION AND BIRTH

If fertilisation takes place in fallopian tube the developing embryo travels down the tube, reaches the uterus in 2 or 3 days. Due to repeated mitotic divisions a hollow ball of cells is formed called the blastocyst. Approximately after one week of fertilisation the blastocyst embeds itself in thickened wall of uterus, in a process called **implantation**. With successful implantation, pregnancy is established. When the rudimentary systems are developed in the embryo it is called **foetus**. The gonadotropic hormones increase produced by placenta which also produces progesterone prolactine, or lactogenic hormones maintains the corpus luteum,

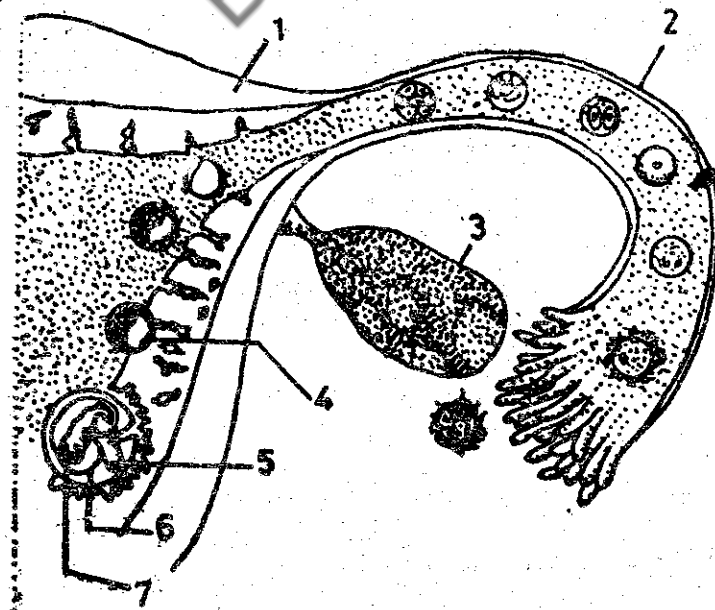

Fig. 34.6 Implantation of the embryo. 1. Wall of uterus 2. Fallopian tube 3. Ovary 4. Blastocyst 5. Yolk sac 6. Amnion 7. Embryo

prevents further growth of Graffian follicles inhibiting FSH. The placenta has two main functions as an endocrine gland and in the transfer of the substances between the mother and foetus. 3 peptide hormones are produced by placenta. Human chorionic gonadotrydine (HCG), human chorionic thyrotrophin (HCT), and human placental lactogen (HPL), in case of human beings.

The development of embryo till the birth of child is called the gestation period. The human gestation period is normally 280 days.

At the end of the gestation period the birth of the child takes place. This process is called parturition. Repeated contractions of myometrium and decrease of progesterone of placenta and release of mytocin from the post lobe of pituitary help in this process. The corpus luteum also secretes relaxin which stimulates relaxation of pelvic ligaments towards the end of pregnancy. After the child birth the first suckle makes the progesterone to disappear and produce the lactogenic hormone by the anterior part of pituitary, this action helps in lactation.

#### Check Your Progress

1. Gestation
2. Parturition

---

### 34.7 SUMMARY

---

1. Physiology of reproduction in mammals - significance.
2. Hormones of testes - function, role.
3. Hormones of ovary - function, role
4. Reproductive cycle of female, mammalian example
5. Implantation - elementary idea, role of hormones
6. Birth - parturition, role of hormones.

---

### 34.8 CHECK YOUR PROGRESS - MODEL ANSWERS

---

1. The development of embryo till the birth of child is called the gestation period.
2. At the end of the gestation period the birth of the child takes place. This process is called Parturition.

---

### 34.9 MODEL EXAMINATION QUESTIONS

---

#### I. Answer the following in about 30 lines:

1. What is female reproductive cycle?
2. Describe the endocrinological control of ovary.

#### II. Answer the following in about 10 lines:

1. Male sex hormones.
2. Female sex hormones.

---

# UNIT - 35 BIOLOGICAL RHYTHMS

---

## Contents

- 35.1 Objectives
- 35.2 Introduction
- 35.3 Biological Rhythms
  - 35.3.1 Circadian Rhythms
  - 35.3.2 Lunar Rhythms
  - 35.3.3 Seasonal Rhythms
- 35.4 Summary
- 35.5 Check Your Progress - Model Answers
- 35.6 Model Examination Questions

---

## 35.1 OBJECTIVES

---

The objective of this unit is to know about Biological Rhythms. At the end of this unit you will be able to explain about kinds of rhythms such as

- circadian rhythms
- Lunar rhythms and
- season of rhythms

---

## 35.2 INTRODUCTION

---

The behaviour of animals or plants that is repeated at different definite intervals is called Biological rhythm. It is a physiological mechanism for measuring time, hence it is called **Biological clock** or **periodicity**. The rhythmic events occur throughout the world. The day and night due to sunset and sunrise, the moving of moon through its monthly cycle, the tides, the seasons have great effect on animals and plants. Temperature, light, humidity, weather and other factors in the environment vary accordingly with each cycle change.

Organisms adapt behaviourally as well as physiologically to these rhythms of nature, to gather food and also to produce offspring. These rhythmic adaptations occur at the level of cells, organs as well as at the level of the whole organism. They exploit the most favourable aspects of the day or month, or season or tide, they can even anticipate them.

Many animals alter their behaviour on a daily basis. For example fruit flies hatch in greatest numbers just at dawn. Cycles of approximately 2-4 weeks are known. Some animals like fishes come on the beaches to spawn at the time of full moon and new moon, that is, at intervals of about two weeks. This behaviour seems to be triggered by the phase of the moon, and or the height of the tides. The human menstrual cycle is a 28-30 days cycle which was also considered as a phenomenon with the phase of the moon.

Migration, reproduction, hibernation in animals happen to take place in specific seasons. The length of the day also affects the rate of reproduction.

## 35.3 BIOLOGICAL RHYTHMS

Biological rhythms can be broadly classified into three categories 1) Circadian rhythms 2) Lunar rhythms 3) Seasonal rhythms

### 35.3.1 Circadian Rhythms

Many animals and plants exhibit a 24 hour cycle in their activities. It has been referred to as diurnal periodicity, which may create slight confusion as opposed to nocturnal periodicity. Photosynthesis is cited as an example. Daily rhythms are called circadian rhythms (Latin, Circa about: and dies day:). The period of circadian rhythm, the number of hours from the beginning of the activity on the next is called free running.

Many plants exhibit other more specialised reactions to the alternation of day and night, such as the opening and closing of flowers and the folding of leaves. A very large number of lower animals exhibit changes in their activities from day to night. It is often a phenomenon of simple photokinesis variation in activity occurs in higher animals. For example mice come out chiefly at night when they are less likely to be detected by their enemies. Most of the predaceous animals are nocturnal as they can capture their prey under the cover of darkness. In an environment such as woods are set of animals is active during the day and the other active only during the night.

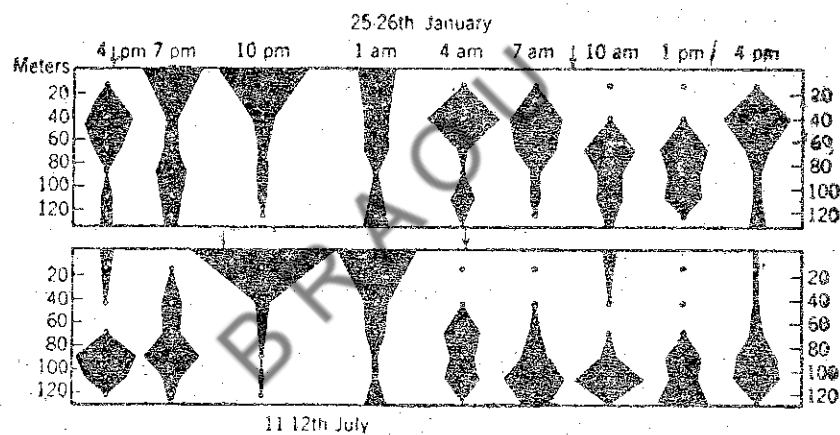

Fig. 35.1 Diurnal Vertical Migration of *Calanus*.

The circadian rhythms have been observed in zooplanktons, polychaete annelids, many insects (Lepidoptera, Diptera, Hymenoptera, Neuroptera, Coleoptera, Orthoptera, Odonata etc); most birds, and certain mammals.

Welsh (1938) and Part (1941) indicated that certain internal physiological processes have become attuned to a 24 hour cycle, in certain animals.

Females of the copepod *Calanus* ascent in the evening and descend in the morning in the Clyde sea. The depth to which these animals migrate is associated with the variations in time of sunset and sunrise and the intensity of the noon sun during January and July. The males and the various young stages of the same species show quite different behavioural patterns in response to light.

Many animals move from the surface to deeper levels in the soil at regular periods each day. Others can act from under the grant litter at definite times during the diurnal cycle and ascend the vegetation. Many other insects move regularly from lower levels in the herbs and

shrubs to higher positions in the trees at sunrise and return at sunset, others migrate in the reverse manner. These changes have effect on prey-predator relations. Phytoplanktons of Dal lake(Srinagar) exhibit diurnal rhythm in reverse order; they are abundant in the surface layer during day time and at depth of 2.5 metres at midnight.

### 35.3.2 Lunar Rhythms

It is a biological rhythm in which the maxima and minima appear once or twice in every lunar month at the same time. If the rhythm occurs once in 15 days it is called **Semilunar rhythm**; if it occurs once in 30 days it called **Lunar**. This cycle, rhythm or clock controls many living activities. It is also called **Tidal rhythm**, **Tidal cycle** or **Tidal clock**.

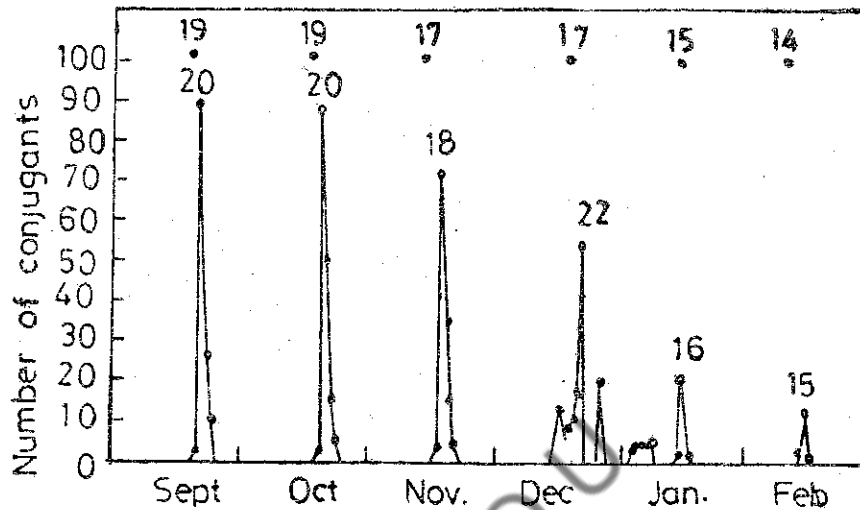

Fig. 35.2 Average daily number of conjugants of *Conchothirus lamellidens*

Fluctuations in the abundance of conjugants produced in *Conchothirus lamellidens* (a ciliate) on the gills of *Lamellidens marginalis* (a fresh water mussel) an ectoparasite is a good example of lunar rhythm. The distant peaks occurred regularly on the days following the new moon. *Dictyota* (a marine algae) produces its gametes at the time of full moon spring tide. *Leuresthes tenuis* (a fish) exhibits a semilunar cycle in its spawning. The gonads of sea urchins expand during the period of the full moon in the Red Sea. The Palolo Worm comes to the surface in great numbers on the last quarter of the moon during October and November producing a luminiscence and discharging eggs and sperms into waters of south Pacific Islands.

The Bermuda Fire Worm (a polychaete) shows display of fire works in the shallow water early in the evening at the time of full moon. Change of local suntime to zonal time at Bermuda was indicated by the appearance of these fire worms 19 minutes after the scheduled time of their appearance.

The grunion fish (*Leuresthes tenuis*) spawns on Malibu Beach near Los Angeles, California, on three or four days after the spring tides from April to June. By the receding of the waves females are left over to bury themselves tail first in the sand. The males then circle around them and fertilise the eggs. For two weeks the eggs are left undisturbed to develop in the warm moist sand. When the next spring tide occurs, the rising tide takes away the hatched young larvae.

Gravitational fluctuations of moon also influence the activity of the fish populations. Many sportsmen have confirmed opinion that these fluctuations influence the success of their fishing.

### 35.3.3 Seasonal Rhythms

They are also called **Seasonal periodicities**, **Annual rhythms** or **Circannual rhythms**. They occur on a yearly (seasonal) basis. Examples of annual rhythms include courtship, nest building and migration of birds; emergence and swarming of insects such as termites; hibernation of mammals and other animals; germination, growth and flowering of plants. The physiological basis of these rhythms varies but in general they are induced by hormonal changes brought about by seasonal changes in temperature and or day length.

The amount of day light per day, known as the **Photoperiod** has a marked influence on the time of flowering of plants, the time of migration of birds, the time of spawning of fish, and the seasonal changes of colour of certain birds and mammals. The effects of the photoperiod on vertebrates appear to be mediated by some neurohormonal mechanism involving the hypothalamus, the pituitary and the pineal. Chicken farmers have found that using artificial illumination in the hen house, and thereby extending the photoperiod, stimulates the hens to lay more eggs.

Shortday and longday are misnomers in view of the work done by many plant physiologists on flowering of plants. For example a cocklebur - graving at the latitude of Michigan, will flower only after it is kept in the dark for 8 hours. If it is illuminated by a flash of light at any time during this period, it fails to flower. These short day plants were really Long Night plants. Some stimulus presumed to be a hormone, is passing from the leaf to the meristems. Spinach bloom successfully on a short day schedule as long as the night periods are interrupted by a brief exposure to light. These long day plants are really Short Night plants. They can bloom only if the nights are not too long.

Eels, Salmon, birds, mammals and insects are considered to be triggered by the photoperiod. Each bird has an internal rhythm (endogenous), adjusted to a definite day length and a bird migrates to such area where that particular day length is available (Example : Tree Swallow).

The larva of pink cotton ballworm found in southern U.S.A goes in a **Diapause** (A stage in which morphological growth and development of an animal is suspended, retarded to develop resistance of extremes of climate) in the months of September and October and remain in this stage during winter. Emergence from diapause begins after spring when the days are slightly longer. In grass hopper, diapause occurs in the egg stage. Kharpa beetle shows low diapause below 30°C. Long days with high temperature and short days with low temperatures are associated in the induction of diapause in *Crapholitha*.

Two theories have been put forward to understand the biological rhythms.

(i) **Theory of exogenous periodicity or rhythm** explains that subtle periodic changes are taking place in the planet, such as magnetic field. These geophysical factors vary cyclically synchronise the organisms' behaviour.

(ii) **Theory of endogenous periodicity or rhythm** explains that animals have internal biological clocks that determine the timings of changes in physiological and behavioural state. Outside stimuli make them to reset their clocks. They also anticipate changes. The rats and rabbits come-out of their burrows when earth quake occurs.

There are daily cycles in a vertebrate such as heart beat, number of W.B.C in blood circulation, excretion of urinary substances.

Air travel and space exploration has made man conscious of circadian rhythm. It take several days to coordinate the rhythms of sleep, digestion with local day-night cycle.

Internal rhythms in honey bee exhibits a time sense too. Many birds, insects and crustaceans make long journeys and employ the sun as an aid to navigation. In doing so, they use internal rhythms to allow for the changing position of the sun in the sky.

**Check your progress**

1. The behaviour of animals or plants that is repeated at different definite intervals is called \_\_\_\_\_.
2. \_\_\_\_\_ is a stage in which morphological growth and development of an animal is suspended or retarded to develop resistance of extremes of climate.

---

**35.4 SUMMARY**

1. Definition of biological rhythms and their role in the life cycle of different living creatures-biological clocks.
2. Circadian rhythms
3. Lunar periodicity (Rhythm)
4. Seasonal periodicity (Rhythm) - Photoperiodicity - Illustration of these manifestations with examples.
5. Theories regarding the Biological Rhythms.

---

**35.5 CHECK YOUR PROGRESS - MODEL ANSWERS**

1. Biological rhythm
2. Diapaus

---

**35.6 MODEL EXAMINATION QUESTIONS**

- I. Answer the following in about 30 lines:
  1. What are seasonal rhythms ?
  2. What are circadian rhythms?
  3. What is a "Biological clock" ?
- II. Answer the following in about 10 lines:
  1. What are Lunar periodicities ?
  2. What is photoperiodism ?

animal against a particular antigenic determinant on a specific antigen molecule will react with it or another very similar structure. Carbohydrates, lipids, nucleic acids and proteins all can serve as antigens. Lipids and nucleic acid are however weak antigens. An antigen must be a foreign substance to elicit an immune response. High molecular weight substance are better antigens. Shape, size and physical state of the antigens also matters.

### Antibodies

Immunoglobulins present in the serum are a heterogenous group of antibody molecules which are always proteins. A great deal of work has been done to understand their structures and it's biological activities. Five classes of immunoglobulins have been described on the basis of their size, chemical composition and functional properties. They are immunoglobulin G (Ig G), Ig M, Ig A, Ig D and Ig E. Ig G is the major immunoglobulin component of the serum making up 80 percent of the total and having a molecular weight of 150,000 in human. The next major component (10%) is Ig M with a molecular weight of 900,000. Ig G consists of one basic unit where as Ig M consists of five such units. Each basic unit consists of two identical heavy and two identical light protein chains giving a Y shaped structure with two branches. Thus two antigen molecules can bind one antibody molecule thus forming a complex. Antigens bind to antibodies reversably by non-covalent interactions. Ig G combats microorganisms and toxins, Ig A exists mainly in the seromucous secretions defending the external body surfaces. Ig M is produced early in the immune response and is very effective bacterial agglutinator. Ig E although present in small amounts is of importance in certain parasitic infections and is responsible for the symptoms of atopic allergy.

---

### 36.3 IMMUNE RESPONSE

---

The purpose of immune response is to defend the host against infection. Non-specific immune mechanisms (e.g. phagocytosis) are enhanced by the development of an adaptive immunity which is specific and has memory.

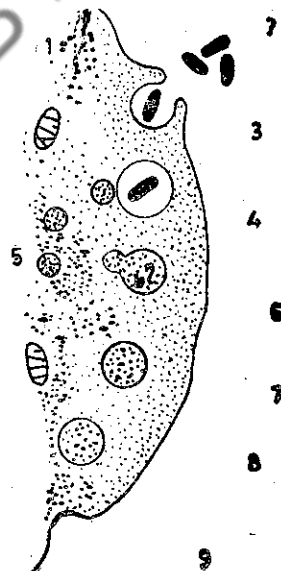

Fig.36.2 Action of a phagocytic cell. 1. Cytoplasm of phagocyte 2. Bacteria 3. Phagocytosis 4. Phagosome 5. Lysosomes 6. Digestive vacuole 7. Digestive vacuole 8. Residual body 9. Elimination

When antigen enters the body, two different types of adaptive immunological reactions may occur. (1) The synthesis and release of free antibody which acts by combining with the antigen and its elimination by phagocytosis, (2) The production of 'sensitized' lymphocytes which become effector cells and bring out the elimination of the invading organism.

The small lymphocyte is the cell which is responsible for both types of immune responses. The primitive lymphoid cells from the bone-marrow appear to differentiate into two types of small lymphocyte populations. 1. 'T' lymphocytes which are processed by or in some way dependent on the thymus and responsible for cell-mediated immunity. 2. 'B' lymphocytes which are bursa dependent and concerned in the synthesis of circulating antibody. In human beings and other mammals there is no bursa and differentiation of B cells seem to take place in haemopoietic tissue of the bone marrow itself.

Both 'T' and 'B' lymphocytes on appropriate stimulation by antigen proliferate and undergo morphological changes. The B- lymphocytes develop in to the plasma cell series which can synthesis and secrete antibody. It has a well-developed rough surfaced endoplasmic reticulum. T-lymphocytes are transformed to lymphoblasts. They do not contain rough surfaced endoplasmic reticulum. However they do elaborate a series of soluble factor which largely act through the macrophage in establishing cell-mediated immunity. A sub-population of antigen-activated T-lymphocytes become cytotoxic and kill the cell carrying the antigen to which they are seen sensitised. It is mentioned earlier that macrophages are phagocytic cells. They, however are also essential for adoptive immune response. In general when antigen is taken up by macrophages,

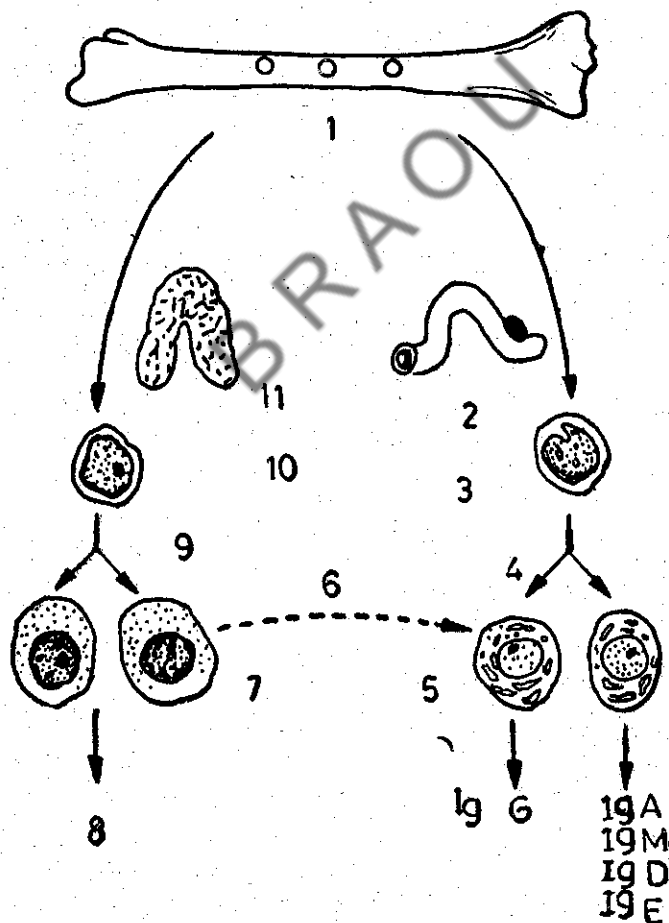

Fig.36.3 'T' lymphocytes and 'B' lymphocytes in the two branches of immune system. 1. Bone marrow stem cells 2. Bursa processing 3. B-lymphocyte 4. Antigen 5. plasma cells 6. Cooperation 7. Lymphoblasts 8. Cell-mediated reactions 9. Antigen 10. T-Lymphocyte 11. Thymus processing.

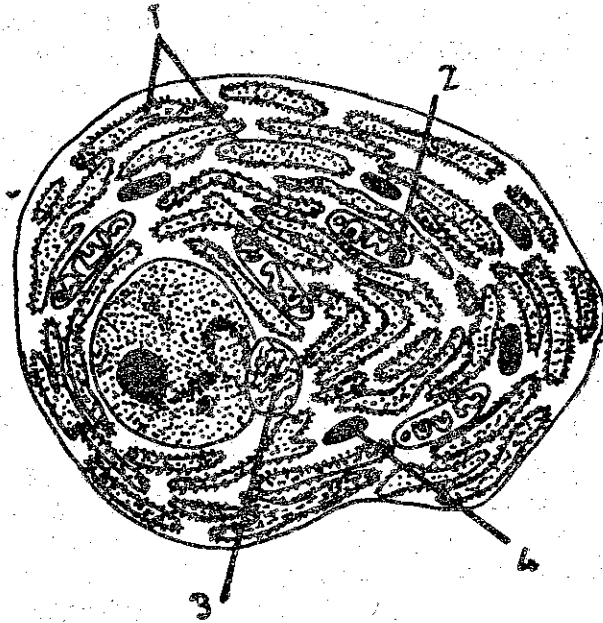

Fig. 36.4 Immunocyte. 1. Endoplasmic reticulum with attached ribosomes 2. Mitochondrion 3. Golgi apparatus 4. Immunoglobulin secretion (Russel body).

a proportion is degraded by phagocytic digestion while part is fixed on cell surface and presented to lymphocyte. This way there is a cellular cooperation between macrophages, T-cells and B-cells to bring out immune responses. Some antigens cannot stimulate B-cell to produce antibodies unless there is help from T-cells. These antigens are T-dependant antigens.

The complex cellular interactions which form the basis of the immune response take place with in the organised architecture of peripheral or secondary lymphoid tissue which includes the lymph glands, spleen and unencapsulated tissue lining the respiratory, alimentary and

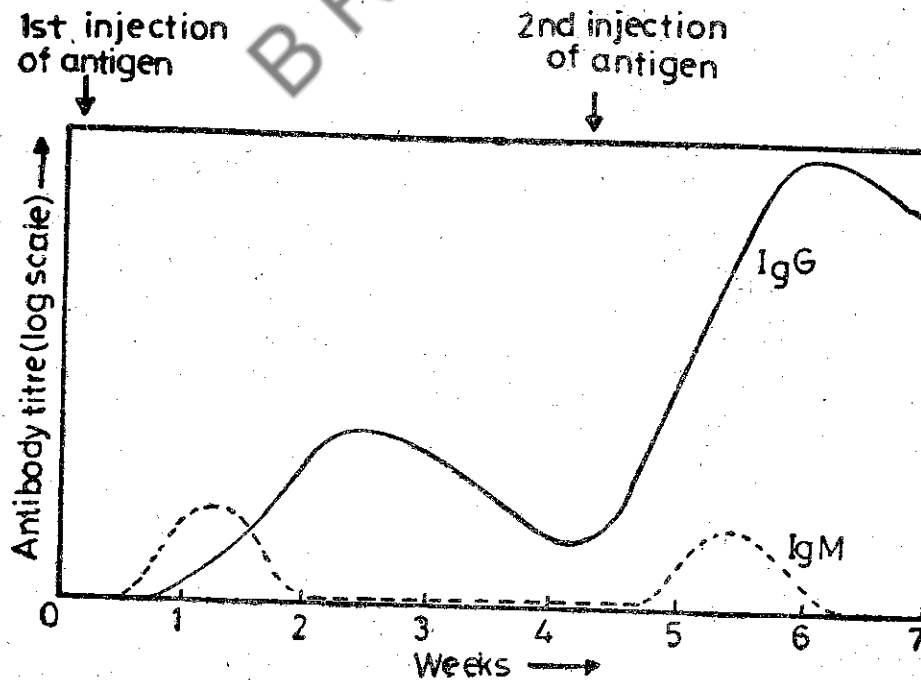

Fig.36.5 Synthesis of Ig M and Ig G antibody classes in the primary and secondary responses to antigen.

genitourinary tracts. Lymph node acts as a filter for lymph draining the body tissue and containing antigens. The T and B cells in the lymph node are separated into different anatomical compartments. Antigens are trapped by lymphocytes in this organ and get sensitized. Similarly spleen which serves as a blood filter has T and B cell areas where antigens interact with the small lymphocyte population.

When an antigen enters into the body and stimulates the immune response say by forming antibodies, this response is known as primary response. When the same animal is exposed to the same antigen after sometime the production of antibodies is very high. This is secondary response. In the primary response some of the sensitized lymphocytes produce antibodies and other remain as antigen sensitive memory cells which respond vigorously in the next challenge. Thus there is memory in the immune response.

#### **Hypersensitivity/Allergy**

When an individual has been immunologically primed, further contact with antigen leads to secondary boosting of the immune response. However the reaction may be excessive and lead to gross tissue damage (hypersensitivity) if the antigen is present in relatively large amounts or if the humoral and cellular immune status is at a heightened level. We may note that these inappropriate reactions are indeed are basically the same which the animal employs to combat any infectious agent. The tissue damage is due to the release of pharmacologically active agents such as histamine which are formed under certain conditions of antigen-antibody combination. The term allergy refers to the hypersensitivity which is associated with the development of the immune response to a foreign substance.

There are two main forms of hypersensitivity reaction, immediate and delayed. The immediate or antibody-mediated form appears rapidly and depends on the production of pharmacologically active mediator substances activated by antigen-antibody interaction. The delayed or cell mediated form appears more slowly, usually after 24 hrs and depends on immunologically activated lymphoid cell which, on reaction with antigen, appear to release substances known as lymphokines having a variety of effects on other cells and effects on blood vessel permeability. The hypersensitivity reactions have been grouped into four categories depending on the mode of their action of which anaphylactic reactions are of serious nature, resulting in death some times. Injection of a drug such as penicillin or the bite of an insect can cause this. Also hay fever and asthma are expression of anaphylactic reaction to an antigen by a sensitized person but localised, in this case, respiratory mucous membrane.

---

### **36.4 BLOOD GROUPS**

---

As early as 1667 attempts have been made to replace human blood lost by hemorrhage, when the transfer of animal blood into human veins was tried. Those transfusions were futile and often fatal. The transfusion of blood from one person to another was some times successful but occasionally led to agglutination (clumping) of the patients' red cells. Antigen-antibody reaction is not to be confused with clotting which is caused by the reaction of thrombin and fibrinogen.

This mystery was for the first time was solved in 1900 by Landsteiner. He found that blood of different persons differs chemically. When the donor's and recipient's blood are incompatible, agglutination occurs. He described the A, B, O groups. Today, there are more than 20 blood group systems expressing more than 160 distinct antigens.

The four chief blood groups, designated O, A, B and AB are distinguished by the presence of agglutinogens (a type of antigen) A or B in the red cells and by agglutinins (a type of

immunoglobulin isoantibodies) a or b in the plasma. The characteristic of the blood groups and the types of transfusion possible are summarized below in a tabular form.

### The Human Blood Groups

The Human Blood Groups				
Blood group	Agglutininogen in Red cells (Antigens)	Agglutinin in plasma (Antibodies)	Can give blood into groups	Can receive blood from group
O	None	A & B	O, A, B, AB	O
A	A	b	A, AB	O, A
B	B	a	B, AB	O, B
AB	A & B	None	AB	O, A, B, AB

Normally, of course, no blood agglutinates itself, because the corresponding agglutininogen and agglutinin (A & a for example) are not present together.

Red cells contain, in addition to the A and B agglutinogens, a second pair known as M and N, inherited independently of the A & B pair, providing additional means of identifying blood.

What happens when bloods of different groups are mixed together in a transfusion? This is given in the following table

D o n o r	Recipient				
		Oab	Ab	Ba	ABo
	Oab	-	-	-	-
	Ab	+	-	+	-
	Ba	+	+	-	-
	ABo	+	+	+	-

Plus indicates agglutination. Minus is no agglutination. The capital letters refer to antigens in the corpuscles and small letters refers to antibodies in the plasma. Group O is **Universal Donor** i.e., can give blood to a recipient of any group. Group AB is universal recipient i.e., can receive blood from a donor of any group.

The Rh factor was discovered in 1940 by Landsteiner and A.S. Weiner from guinea pig, immunised with the blood of a monkey *Macaca Rehesus*. Guinea pigs produced antibodies when blood of rhesus monkey was injected into them. The red cells of the rhesus monkey agglutinated. It confirmed the phenomenon that the red cells of all monkeys of this species contain a particular antigen, which has been designated Rh. With this guinea pig serum, when human blood was tested, some persons blood clumped and some one's blood did not. It indicated that some persons were Rh<sup>+</sup> (Rh positive antigen), and some persons Rh<sup>-</sup> (Rh negative antigen). The former one is a dominant factor and the later one is a recessive tract.

If Rh- negative woman marries with Rh<sup>+</sup> man, she becomes sensitized simply by carrying a positive child within her body. Some of the cells from the embryo may mix up into her own blood stream during prenatal development. The first child is usually normal. In the second pregnancy the antibodies of the mother pass through the placenta and cause damage to the cells of the foetus. This disease is called erythroblastosis foetalis, which consists of an anemia due to breakdown of RBC in foetus-haemolysis and consequent jaundice as the blood vessels in the liver become clogged with the broken cells and bile is absorbed by the blood. It may

cause death before birth or death within a few days after the birth. It is also known as haemolytic disease. About 85% of the white population of western Europe and North America is Rh positive.

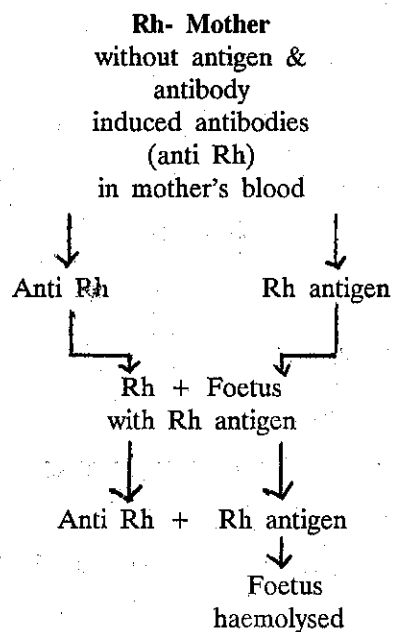

#### Check your progress

1. When a person can withstand repeated exposure to a disease without taking it, he is said to be \_\_\_\_\_ to that disease.
2. If Rh<sup>-</sup> woman marries with Rh<sup>+</sup> man, she becomes sensitized simply by carrying a positive child within her body. The first child is normal. In the second pregnancy the antibodies of the mother pass through the placenta and cause damage to the cells of the foetus. This disease is called \_\_\_\_\_

---

### 36.5 SUMMARY

---

1. Definition
2. Innate/specific responses
3. Antigen
4. Antibody
5. Cell mediate immunity
6. Humoral immunity
7. Allergy/Hypersensitivity
8. Blood groups

---

### 36.6 CHECK YOUR PROGRESS - MODEL ANSWERS

---

1. immune
2. erythroblastosis foetalis

---

## 36.7 MODEL EXAMINATION QUESTIONS.

---

**I Answer the following in about 30 lines each:**

1. What are non-specific defence mechanisms?
2. What are immunoglobulins?
3. What are specific defence mechanisms?

**II. Answer the following in about 10 lines each:**

1. What are antibodies?
2. What is transfusion of blood?

---

## 36.8 GLOSSARY:

---

1. **Antibody** : A protein produced in response to the presence of some foreign substance in the blood of tissues.
2. **Antigen** : A foreign substance usually protein that elicits formation of specific antibodies within an organism.
3. **A.T.P.** : Phosphorylated chemical (Adenosine Triphosphate) important for energy transfers with in the cells.
4. **Artery** : A blood vessel that carries blood away from the heart.
5. **Ascorbic Acid** : Same as Vitamin C
6. **Blood Group** : Type of blood
7. **Blood** : Liquid connective tissue
8. **Balanced Diet** : Diet containing essential nutrients in proper proportion.
9. **Biotin** : One of the B-Vitamins.
10. **Bomb Calorimeter** : An instrument used for determining the gross energy content of a material.
11. **Bran** : The pericarp or seed coat of grain removed during processing.
12. **Capillary** : A small, thin walled vessel especially the smallest vessel of the circulatory system.
13. **Caloric** : The amount of energy as heat required to raise one gram of water  $1^{\circ}$  C.
14. **Carotene** : An yellow organic compound; precursor of Vitamin A.
15. **Dermatitis** : Inflammation of the skin.
16. **Emaciation** : An exclusively thin condition of the body.
17. **Foetus** : In Mammals, the young in the later stages of Intra-Uterine development.
18. **Gastrointestinal** : Pertaining to stomach and intestine.
19. **Goitre** : An enlargement of the thyroïd gland caused by iodine deficiency.
20. **Harmone** : A complex substances secreted by an endocrine gland, directly into blood.

21. **Haemorrhage** : Copious loss of blood through bleeding.
22. **Immune Response** : Production of antibodies in response to antigens.
23. **Jejunum** : Middle portion of small intestine which extends from duodenum to ileum.
24. **Lymph** : A lymphoid gland in most young and many adult vertebrates, disappears in Man at puberty, located in lower throat and upper part of thorax.
25. **Luminescence** : Emission of light.
26. **Myofibril** : A contractile fibril found with in muscle cell.
27. **Neuritic** : Pertaining to the nerves.
28. **Oogenesis** : The process of the formation of an egg.
29. **Oedema** : Swelling of a part or the entire body due to accumulation of excess water.
30. **Plasma** : The liquid portion of the blood.
31. **Parturition** : Birth of young.
32. **Photoperiod** : Duration of day light.
33. **Phytoplanktons** : Microscopic floating plants.
34. **Predator** : An animal which lives by devouring other organisms.
35. **Pasture** : Forages which are harvested by grazing animals.
36. **Sphincter** : A smooth muscle ring in the wall of a tubular organ of surrounding a circular opening.
37. **Skeletal Muscle** : Elongated mass of tissue containing many muscle fibres bound together by connective tissue fibres.
38. **Spermatogenesis** : The process of the formation of sperm.
39. **Thymus** : A lymphoid gland in the most young and many adult vertebrates, disappears in Man at puberty, located in lower throat and upper part of thorax.
40. **Tetany** : A syndrome involving sharp flexion of wrist and angle joints, cramps and convulsions.
41. **Vein** : A blood vessel which carries blood towards the heart.
42. **Zooplanktons** : Microscopic floating animals.

### 36.9 SUGGESTED READINGS

1. Review of physiological chemistry - Harold A. Harper
2. General and comparative physiology - P.S Verma, V.V. Agarwal B.S. Tyagi
3. Anderson, L. and Browe (1975) - Nutrition and family health service
4. Cullison, A.E, (1978) - Feeds and Feeding
5. Robinson, C.H. (1982) - Normal and therapeutic Nutrition
6. Taylor, C.M. and pyre, G (1985) - Animal nutrition
7. Essential Immunology - I.M. Roilt
8. Immunology - D.M. Weir
9. Immunology - N.H. Eisen

10. Understanding Immunology - A.J. Cunningham
11. Biology - Kimball
12. Biology - Ville
13. Ecology - Varma
14. Ecology - Clark
15. Biology - B.V. Roberts
16. Animal physiology - Goel & Sastry
17. Essentials of Animal Physiology - S.C. Rastogi.

BRAOU

**ANDHRA PRADESH OPEN UNIVERSITY**  
**SYLLABUS - PAPER - III**  
**GENERAL ZOOLOGY**  
**(CYTOLOGY, GENETICS, EVOLUTION,**  
**ZOOGEOGRAPHY, ECOLOGY & ANIMAL PHYSIOLOGY)**

**THEORY**

**CYTOLOGY**

- Historical account of Cytology : Methods of study : Ultra structure of the cell.
- Structure and function of cell organelles : Plasma membrane : Endoplasmic reticulum : Golgi Complex.
- Structure and function of cell organelles; Mitochondria; Lysosomes; Centrioles; Ribosomes; Nucleus.
- Chromosomes; Morphology, Ultra structure, Molecular compounds and Special types of chromosomes.
- Cell division : Amitosis, Mitosis, Meiosis, Cell cycle
- Fertilization; Gametogenesis; Parthenogenesis

**CLASSICAL GENETICS**

- Historical account; Importance of Genetics and its application.
- Mendal's laws of inheritance.
- Linkage and Crossing over
- Sex determination
- Sex linked inheritance.
- Chromosomal aberrations, Gene mutations : Spontaneous and induced.
- DNA, Replication of DNA, RNA; Genetic Code, Elementary knowledge about Protein synthesis
- Fine structure of gene; Classical definition, Modern definition; Cistron, Muton and Recon and Operon Concept.
- Human genetics : Gentic traits in man, Human sysndromes, Inborn errors of metabolism

**EVOLUTION**

- Origin of Life (brief account); Organic evolution : Theories (Darwinism, Lamarcism, Mutation theory) : Evidences (Embryologica, Palaeontologica, Physicological and biochemical).
- Synthetic theory of Evolution - Mutations, Genetic recombinations, Genetic drift, Natural selection and Isolation.
- Adaptations : Aqustic, Desert, Volant adaptions; Commensalism; Mutalism : Symbiosis, Parasitism; Colouration and Mimicry
- Evolution of Man (briefly) and horse.

**ZOOGEOGRAPHY**

- Zoogeographical realms with special reference to Oriental fauna

**ECOLOGY**

- Introduction of Ecology; Various branches and its relation to other sciences, Fundamental concepts of Ecosystem taking terrestrial, Pond and Estuarine as examples, Food chains, Energy flow, Trophic levels.
- Ecological factors; physical factors - temperature, light, Water; their effects on organisms; Adaptations of organisms; Adaptions of organisms to these factors.

# ANDHRA PRADESH OPEN UNIVERSITY

Faculty of Science

ZOOLOGY

COURSE - III

(Cytology, Genetics, Evolution, Zoogeography,  
Ecology and Animal Physiology)

ASSIGNMENT - 3

N.B.

1. Do not copy the answer directly from any of the books.
  2. As far as possible try to answer the questions independently in your own words.
  3. If it is necessary to quote from any source give the correct reference.
  4. Use your own foolscap pages for writing the assignments.
  5. Leave sufficient margins for the comments of the evaluator.
  6. Completion of this assignment should not take more than two hours time.
- 

**I. Answer the following questions in about 30 lines:**

1. Give an account of 'Operon Concept' with reference to regulation of gene action.
2. In what respects Darwinism and Lamarckism agree to differ?
3. Write briefly about the mechanism of contraction of a muscle lapsing stress on ATP coupling theory.

**II. Answer the following questions in about 10 lines:**

1. Types of chromosome based on Centromere location.
2. Describe the mechanism of DNA replication and mention its significance.
3. Describe briefly the process of Chemical transmission.

BRAOU  
LIBRARY

BRAOU

**Dr. BRAOU  
LIBRARY**

**ANDHRA PRADESH OPEN UNIVERSITY  
LIBRARY**

Call No. <sup>591</sup> 200

Accession No. 21503

Author D. B. R. A. O. U.

Title Zoology -  
Fishery Science.

This book should be returned on or before the date last marked below:

--	--	--	--

BRAOU

No. 57470  
P. A. V.  
ZOOLOGY  
LIBRARY  
1980

BRAOU

# ZOOLOGY

FISHERY SCIENCE

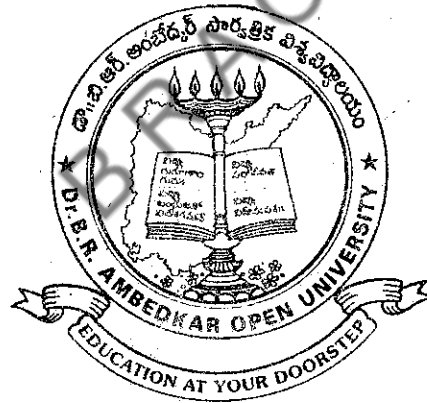

**DR. B.R. AMBEDKAR OPEN UNIVERSITY**  
**HYDERABAD**  
**1992**

21503  
1-12-93

# COURSE TEAM

**Editor**  
Dr. C.V. Reddy  
**Writers**  
Dr. M. Babu Rao  
Dr. K. Gopal Rao  
Dr. G. Sai Prasad  
Sri A.T.S. Janak

**Associate Editor:**  
Dr. (Mrs.) Girija Neti

**Dr. BRAOU  
LIBRARY**

**Cover Design & Graphics**  
M. Ramesh

<b>Dr. B R A O U LIBRARY</b>	
<b>A.</b>	21503 .. ..
<b>Date ..</b>	1-12-93 .. ..
<b>Call No. ..</b>	571 200 .. ..

BRAOU

**A  
Hyderabad**

First Published in 1985

Copy Right - 1985 Dr. B.R. Ambedkar Open University.

All rights reserved. No part of this book may be reproduced in any form without permission in writing from the University.

This text forms part of Open University Course.

Further information on Open University courses may be obtained from the Director (Academic),  
Dr. B.R. Ambedkar Open University, Hyderabad - 500 482, A.P.

Phototypesetting at Shri Gopala Kwik Graphics & Printed at Shri Gopala Kwik Graphics, Hyderabad.

## P R E F A C E

This book deals with the various aspects of Fish Culture as per the syllabus for the third year of the Zoology course offered by the Dr. B.R. Ambedker Open University. These topics generally cover the 'Special' subject to be studied in the third year of three year degree course in B.Sc. The syllabus is divided into 20 units each unit generally covers a specific area of the subject. The units are prepared by specialists of the various fields of the Department of Fishery Science, A.P. Agricultural University. The language and presentation are so oriented to enable the student to read and understand them without much difficulty. Each unit starts with a statement of its objectives followed by synopsis and the actual presentation of the unit and has at its end assignments intended to test the students comprehension of its subject matter, meanings of technical terms with which the student may not generally be familiar are given at the end of each unit under the head 'Glossary'.

Unit-I deals with the Fishery institutes in India. Unit-II is about the migration of Fishes. Unit-III gives a brief idea about the anatomy of Fish.

The rest of the units deal with the introduction of fish culture. It covers the aspects of the history, present status, fishery resources, selection of species for culture, taxonomy and identification of cultivated fishes and prawns.

In biology of cultivated organisms, food and feeding habit, age and growth, breeding habits, life history of important fishes and prawns are covered.

In another unit, the subject of seed production is dealt, in which collection of seed from natural resources and bundh breeding, induced breeding, hatchery systems and seed transport is discussed.

The study relating to farm pond construction, comprises of three units describing site selection, design and constructivity of ponds, water and soil quality, food chain and productivity as well as pond management.

Various aspects of culture systems deals with fresh water aqua culture systems.

In fish nutrition and health monitoring aspects, nutritional requirements and supplementary feeding, fish diseases, their causes, symptoms and control are discussed.

Fishery technology comprises the aspects of preservation, processing and transportation, fish byproducts, crafts and gear used in fishing.

The fishery extension activities includes promotion of fish culture, extension methods and extension programmes.

The above course material, covering various aspects of fish culture in a brief way, has been included in this book, with a hope that the student will be acquainted with the different aspects of 'Fish Culture' both in Inland waters and coastal waters with special reference to cultivable fishes and prawns.

To improve this work, useful suggestions are welcome so that in the coming editions the improvements will be incorporated.

BRAOU

## CONTENTS

Unit-1	:	Fishery Institutes in India	1
Unit-2	:	The migration of Fishes.	4
Unit-3	:	Anatomy of a bony fish.	7
Unit-4	:	Introduction of Fish Culture, History, Present status and Fishery resources.	12
Unit-5	:	Selection of species for culture, Taxonomy and identification of cultivated Fishes and Prawns.	20
Unit-6	:	Food and Feeding. Age and growth and breeding habits of important fishes and prawns.	34
Unit-7	:	Life history and identification of eggs, larva and juveniles of cultivated fishes and prawns.	39
Unit-8	:	Seed production - Collection of seed from natural resources and bundh breeding.	50
Unit-9	:	Seed production - Induced breeding, hatchery systems and seed transport.	57
Unit-10	:	Farm pond - Site selection, Design and Construction of Pond.	68
Unit-11	:	Farm Pond Water and soil quality, food chain and productivity.	76
Unit-12	:	Farm Pond - Pond management.	89
Unit-13	:	Freshwater Aquaculture systems.	107
Unit-14	:	Coastal Aquaculture and Mariculture systems	121
Unit-15	:	Fish nutrition and health monitoring - Nutritional requirements and supplementary feeding	135
Unit-16	:	Fish Diseases - Causes, symptoms and control.	141
Unit-17	:	Fishery Technology - Preservation, Processing and Transportation.	153
Unit-18	:	Byproducts.	163
Unit-19	:	Crafts and Gears.	174
Unit-20	:	Promotion of Fish culture, Extension methods and Extension Programmes.	200

BRAOU

# **UNIT - 1 FISHERY INSTITUTES IN INDIA**

Fish is a valuable, nutritious and easily accessible source of food, which is rich in proteins and vitamins. India has an abundant marine and inland fish resources. It has a coastal line c,4,667 K.M. long. Offering considerable scope for the establishment of Fisheries.

In order to study the distribution and bionomics of marine fishes and to know about the fisheries management a detailed research activity coupled with fisheries. Administration is required. Hence the following research laboratories are established for this purpose.

1. Central Marine Fisheries Research Institute  
(C.M.F.R.I.) - Ernakulam - Kerala.
2. Central Institute of Fisheries Technology.  
(C.I.F.T.) - Cochin - Kerala
3. National Institute of Oceanography - Panaji - GOA.
4. Central Inland Fisheries Research Institute  
(C.I.F.R.I.) Barrackpore, West Bengal.
5. Central Institute of Fisheries Education  
(C.I.F.E.) - Bombay
6. Zoological survey of India - Calcutta.

## **1. CENTRAL MARINE FISHERIES RESEARCH INSTITUTE (C.M.F.R.I.) ERNAKULAM - KERALA**

This Institute is carrying out research on various aspects of Fish fisheries, prawn fisheries, Molluscan fisheries etc. It has its branches at various coastal towns in India. Such as Madras Mandapam, Visakhapatnam, Kakinada, Bombay Veeraval etc.

## **2. CENTRAL INSTITUTE OF FISHERIES TECHNOLOGY (C.I.F.T.) COCHIN - (KERALA)**

This Institute was started at Cochin in 1957 to carry out research work on fishing craft and Gear. In 1958, it started the processing division also. Later it started Biochemistry and Microbiology division, Engineering division, Extension, information and statistics division.

### **Headquarters - Cochin**

The crafts division is carrying out investigations towards evolving cheap construction materials for fishing boats. And also methods for protecting them from marine deterioration etc.

The Gear division is carrying out work on the merits and demerits of various natural and synthetic fibres for fabrication of fishing gear. They are also working on several methods for preservation of gear different types of gear.

The processing and packing division undertaking methods for processing of factory wastes, preparation of various fish byproducts like, fish oil, fishmeal, fish flour etc.

### **OTHER RESEARCH CENTRES**

#### **VEERAVAL RESEARCH CENTRE (GUJARAT)**

This centre was set up in 1962.

#### **KAKINADA RESEARCH CENTRE : (A.P.)**

This centre was also set up in 1962 to introduce commercial trawling from small and medium size boats for exploitation of prawn resources of this region. To evolve standard designs of trawl nets and other boards.

#### **BURLA RESEARCH CENTRE (ORISSA)**

This centre was set up in 1963 to develop suitable gear and methods for reservoir fishing.

#### **PANAJI RESEARCH CENTRE (GOA)**

This centre was established in 1964. With a view to introduce trawling for commercial exploitation of the prawn resources.

#### **BOMBAY RESEARCH CENTRE (MAHARASHTRA)**

This centre was established in 1958 to tackle and specific problems relating to freezing and frozen storage of fishes.

#### **CALICUT RESEARCH CENTRE (KERALA)**

This centre was set up in 1962 to tackle the problems of the fish curing industry.

### **3. NATIONAL INSTITUTE OF OCEANOGRAPHY PANAJI (GOA)**

In this institute research work is being carried out on various aspects such as Biological, Physiological, Chemical, Geological aspects. They also carry out Marine Biological expeditions, of late they are conducting expeditions to Antarctica.

### **4. CENTRAL INLAND FISHERIES RESEARCH INSTITUTE (C.I.F.R.I.) BARRACKPORE, WEST BENGAL**

In this institute research work is being carried out on various aspects of inland fisheries.

### **5. CENTRAL INSTITUTE OF FISHERIES EDUCATION (C.I.F.E.) BOMBAY**

This institute is one of the pioneer institutes in India in the field of Fisheries Education. This institute was established at Bombay in 1961. Its head quarters also at Bombay.

This Institute has training centres at Barrackpore (West Bengal), Kakinada (A.P.) and Chinhet (U.P.). This institute conducts specialised courses on all aspects of fisheries and these courses relate mainly to train to personnel of all states fisheries departments, and Fisheries organisations. It also started M.Sc. (Fisheries Management)

#### **ZOOLOGICAL SURVEY OF INDIA:**

Its head quarters is at Calcutta. It has branches in almost all states. They are carrying out taxonomical work. Identification of new specimens. And lot of research work is going on.

Zoological survey of India was started by Govt. of India in 1916. Now ZSI is under Dept. of Science & Technology. And it has ten Regional Stations.

#### **1. Northern Regional Station, Z.S.I.**

Dehradun (U.P.)

2. Eastern Regional Station, Z.S.I.  
Shillong (Meghalaya)
3. Western Regional Station, Z.S.I.,  
Poona (Maharashtra)
4. Central Regional Station, Z.S.I.,  
Jabalpur (M.P.)
5. Desert Regional Station, Z.S.I.,  
Jodhpur (Rajasthan)
6. Southern Regional Station, Z.S.I.,  
Madras (Tamilnadu)
7. Gangetic Plains Regional Station, Z.S.I.,  
Patna (Bihar)
8. High Attitude Zoology Field Station Z.S.I.,  
Solun (H.P.)
9. Estuarine Biologist  
Hillpatna Berhampur (Orissa)
10. Freshwater Biologist  
Hyderabad (A.P)

The ZSI functions as the guardian of National Zoological collections of India. It even identifies zoological specimens for Govt. departments, and all other institutes. It is carrying out faunistic surveys in different parts of India and research work in systematic Zoology. Animal Ecology, Zoogeography, Animal population and Behavior and Marine Fauna. It publishes zoological journals monographs and books and advises on matters regarding wild life.

ZSI has a collection of over 8,00,000 identified specimens.

ZSI carries out periodical faunistic surveys throughout India.

They are carrying out research on several aspects connected with medical, veterinary, agricultural and allied problems including pollution. ZSI is recognised by Inter University board for Ph.D programme.

---

## UNIT - 2 THE MIGRATION OF FISHES

---

Migration is the movement of animals from one place to another. The cycle of migrations usually consists of the following:

1. Spawning migrations: i.e. The movement of fishes from the feeding or over wintering grounds to the spawning grounds.
2. Feeding migrations: a movement away from the spawning or over wintering grounds to the feeding ground.
3. Wintering migrations: a movement away from the spawning or feeding grounds to the over wintering grounds.

In some species the migrations are performed only by the adult fishes, while the young won't show any movements. e.g.: many species of the salmon family. In other species. The young make migrations along with adults. e.g: In the shad *caspiatosa brashnikovi* (Borodin) both the adults and young pass from the over wintering grounds out of the southern caspian into the Northern Caspian in which the spawning and feeding grounds of this fish are distributed.

Generally the start of the migration depends on both the state of the fish itself and the environmental changes. The time at which the migration starts evolves as an adaptation which ensures favourable conditions for both the fish and for the future offspring.

The spawning, feeding and wintering migrations are mutually related. In many cases part of the migration course is performed passively and part actively, as happens for example, in the larvae of the common eel in them from the west of central America to the coast of Europe. This movement is at first performed passively together with the water of the atlantic current, but on approaching the coast. The elvers start to migrate actively to the rivers. In nature. We observe that in many fishes the males or part of the males always live in the rivers, while the females lead a migratory mode of life. This phenomenon has been recorded for Salmon, barbels, and certain other fishes.

The basic factor is the evolution of the migration cycle of migratory, primarily fresh water, fishes in the insufficient food supply in the rivers.

For primarily marine fishes, which lead a migratory life, the conditions for the development of the eggs are more favourable in the rivers than in the sea. So the fish is adopted to spawning in flowing water.

The migration is an adaptation towards increasing the abundance of a species eg. the shad *caspiatosa brashnikovi* in the caspian sea of which the type that performs considerable migrations from the south to the north caspian is considerably the more abundant form. There is also a similar pattern in the oceanic lessing, *cluppa hareugus*. The most abundant forms are the Norwegian and sakhalin - Hokkaido herrings which performs the longest migrations, ensuring the largest feeding areas as for them. (Svetovidov 1953) In many fishes (Salmon, white fish) the change to a migratory mode of life was made easy because of the dilution of the sea which occurred in the northern hemisphere. However the existence of migratory fishes in the subtropical, tropical and equatorial zones indicates that the dilution of the sea is not the only cause for the invitation of the migratory mode of life.

The length and character of the migration course which the fish performs is most closely related to the structure and condition of the migrating fish. The larger, stronger, and fatter fish is able to cover the greater distances and to swim for a long time against a fast current. This principle is observed both for different species, and for different forms of the same species.

eg: *Caspiatosa Resslereri* - perform longest migration where as large eyed shad pryank - does not enter the rivers.

The same is also observed in the various forms of a single species. eg: the autumn chum salmon, *Oncorhynchus keta autumnalis*. This is longer than the summer form. The autumn forms will migrate in the estuary of the Amur upto 1500 km, summer forms upto 400-500km.

In performing their migration, some times over many thousands of kilometers, fishes successfully locate the spawning grounds by means of their same organs. Nearly all fishes migrate in shoals. The migrating shoal of fish usually has a definite shape, which ensures the most favourable hydrodynamical conditions for movement. (Shuleikin 1953).

A fundamental method of studying the migrations of fishes is by marking them. Various types of marks are used. eg. gilbert mark, peterssen mark, lea hydrostatic tag, and internal metallic mark (for marking herrings)

Hydro acoustic instruments are very important for the study of migrations and the distribution of fishes.

**SPAWNING MIGRATIONS:-** The spawning migration is a movement away from the overwintering or feeding grounds to the spawning ground.

There are two types of spawning migrations namely Andromous and Catadromous migrations

**ANADROMOUS MIGRATIONS:-** In this type many migratory fishes and cyclostomes feed in the sea, but enter the rivers to spawn. Eg. Lampreys, Sturgeonl, Salomon, Some shads, cyprinoids etc.

**CATADROMOUS MIGRATIONS:-** In this case some migratory fishes feed in the rivers, but pass out into the sea to spawn eg. Freshwater eel etc. The most complex catadromous spawning migrations are those of the American & European eels.

The migration may be against the current or contranant, or else with the current or denatant. In some fishes apart of the spawning migration is contranant and part denatant.

In some fishes, such as certain sturgeons, the Atlantic salmon, *salmo salar*. There are winter and spring roces, which differ in the time of their approach to the rivers. Thus the salmon which enters the rivers of the white sea is represented by two forms. One enters the rivers in the autumn. The other group enters the rivers in the summer.

The time of onset of the spawning migrations varies greatly from species to species. Many white fishes start their spawning migrations in the autumn the majarity of cyprinoids in the spring. The length of the migrations upriver varies from a few to several thousand kilometers. During the migrations especially against the water current has to use more energy & as a result the fat content will down and the fish will deteriorate.

In connection with the change in osmo-regulation and the cessation of feeding in the rivers, very great changes take place in the size of the intestinal tract of migrating fishes. This is particularly well expressed among the salmon family.

The amount of energy depended by migrating fishes in order to reach their spawning grounds is very great. And also when they leave the sea-water there is a change in the vitamin content of the flash of migratory fishes.

Many marine and some fresh water fishes perform vertical spawning migrations, rising from the deep layers to the surface. Thus many deep water fishes of the order scopeli former rise to spawn, in the upper layers. Among freshwater fishes the clearest example of a vertical spawning migration is that of the Lake Baikal comphoridae.

**FEEDING MIGRATIONS:-** The feeding migration consists of a movement away from the spawning or over wintering grounds to the feeding grounds. In many fishes the feeding migration

even begins in the egg stage. The transport of the pelagic eggs and free embryos from the places where they were spawned to the feeding grounds is a passive feeding migration. Passive feeding migrations are found in migratory marine, and fresh water fishes. An example of a passive feeding migration is the transport of the eggs and larvae of the migratory shad and the Aral sea barbel from the spawning grounds to the feeding grounds of the fry. Marine fishes also perform passive feeding migrations. The eggs and larvae of the cod and the larvae of the herring are transported by the Atlantic current from the coast of Norway to their feeding grounds in the Barents sea.

Passive feeding migrations have also evolved among freshwater fishes.

Among marine fishes the Norwegian herring, *Clupea harengus* is the best example for feeding migrations.

Besides horizontal feeding migrations, many marine fishes perform regular vertical movements in search of food. The mackerel rises into the surface waters where there is a rich development of plankton there.

Feeding migrations are also often clearly expressed in fishes of inland waters. eg. The bream and the white eyed bream in the Aral sea, after spawning move into great depths. Where they find rich food.

**OVERWINTERING MIGRATIONS:-** The overwintering migration is a movement away from the feeding to the wintering grounds. It only occurs in those fishes which have a wintering ground. The winter form of the migratory fishes move from the feeding grounds in the sea to the wintering grounds in the rivers, where they concentrate in deep pits and overwinter in a somewhat inactive state and usually not feeding.

eg: sturgeons, atlantic salmon, Aral Sea barbel, (these are among migratory fishes)

Among semi-migratory fishes overwintering migrations take place in the adult stage, sea roach, loach, pike-perch. Some marine fishes also perform overwintering migrations.

eg: flat fishes, *Engraulis encrasicolus*

The overwintering migration is also expressed in many fresh water fishes eg. grass-carp, *Ctenopharyngodon idella*.

All the types of migrations - spawning feeding, and overwintering - are links in a single migration cycle.

---

# UNIT - 3 ANATOMY OF A BONY FISH

---

## Contents

- 3.1 Objectives
- 3.2 Introduction
- 3.3 Digestive System
- 3.4 Respiratory System
- 3.5 Nervous System
- 3.6 Urinogenital System
- 3.7 Summary
- 3.8 Check Your Progress - Model Answers
- 3.9 Model Examination Questions

---

## 3.1 OBJECTIVES

---

The objectives of this unit is to know about the anatomy of a bony fish, particularly, to study in detail about the importance of digestive, respiratory, nervous and urinogenital systems.

---

## 3.2 INTRODUCTION

---

As fish is very nutritious and as it contains lot of proteins and vitamins, it is very essential to study its anatomy. So, that one can know its habits, and thus can try to grow it in captivity. Fish-food, its digestion, respiration, nervous activity and reproduction are interlinked. So, to know about these systems in fish will help a person to grow fish in larger quantities in captivity.

---

## 3.3 DIGESTIVE SYSTEM

---

The **mouth** is terminal and lies at the anterior end of the body. Teeth are absent. Muscular tongue lies on the floor of the buccal cavity. The pharynx is perforated at its sides by four pairs of gill-slits. Behind these and at the junction of pharynx and oesophagus, there are pharyngeal teeth, which filter mud and other substances.

The stomach consists of two parts, an anterior tubular part known as **cardiac stomach**, having longitudinal folds for its inner lining and a posterior globular part called **pyloric stomach**, with thick muscular walls. This thick part is also called **gizzard**. A small **caecum** lies behind the cardiac stomach. The gizzard is followed by the **duodenum**. At the junction of these two there will be blind glandular tubular processes called the **pyloric caeca** and these are characteristic of teleostei. Duodenum is followed by **ileum**. This is longer and coiled and is devoid of spiral valve. Behind ileum is **rectum**, which opens to the outside through anus.

The **liver** contains three incompletely divided lobes. The **gall - bladder** lies in the lower margin of the right lobe and the **bild duct** leads from it into the **duodenum**. The **Pancreas** is diffused and lies in the mesentery. The **spleen** lies towards the outer side of the stomach.

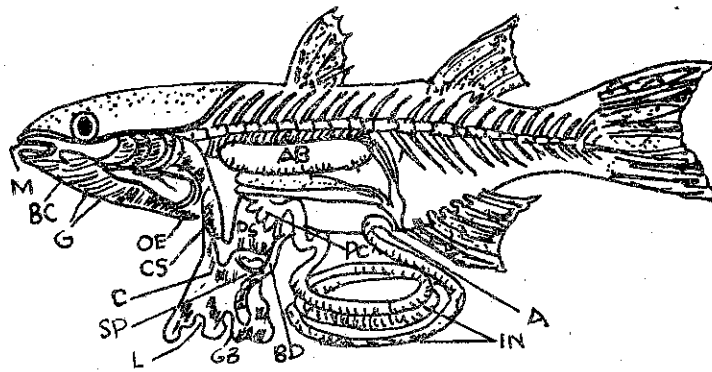

Fig 3.1. Digestive System

A, anus; AB, air-bladder; BC, buccal cavity; BD, bile duct; C, Caecum; CS, cardiac stomach; G, gills; GB, gall-bladder; IN, intestine; L, liver; M, mouth; OE, oesophagus; PC, pyloric caeca; PS, pyloric stomach; SP, spleen;

### 3.4 RESPIRATORY SYSTEM

Respiration takes place by gills. There are four pairs of pharyngeal gills. The partitions between the gill-slits are narrow and the filaments project freely into the cavity beneath the operculum. The mucous membrane lining the gill-pouches is thrown into a number of horizontal folds which are richly supplied with blood capillaries.

**MECHANISMS OF RESPIRATION:** First water is sucked into the mouth by depression of the floor of the buccal cavity. Next the mouth is closed and the cavity of the pharynx is enlarged. The water from the buccal cavity passes through the gill-slits bathing the gills. As the water passes through the gills, interchange of respiratory gases takes place. Oxygen dissolved in the water passing to the blood and carbondioxide from the blood to the water. The oxygenated blood is taken to the various parts of the body and the water passes out.

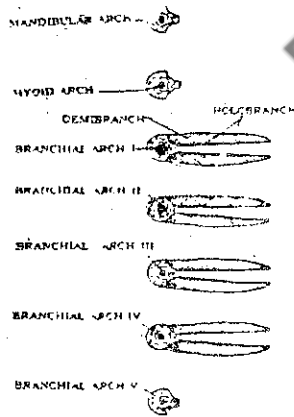

Fig. 3.2 Arrangement of Gill Arches

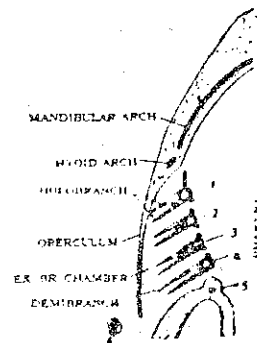

Fig 3.3 Relation of gills to branchial chamber

### 3.5 NERVOUS SYSTEM

The nervous system of all chordates is divided into three units as 1. Central Nervous system (CNS) 2. Peripheral Nervous System and 3. Autonomic Nervous System

The central nervous system comprises of Brain and spinal cord, while the peripheral nervous system comprises of cranial nerves which arise from brain, and spinal nerves which arise from the spinal cord, whereas the Autonomic nervous system consists of sympathetic and parasympathetic nerves.

**CENTRAL NERVOUS SYSTEM: (CNS)** This consists of Brain and spinal cord.

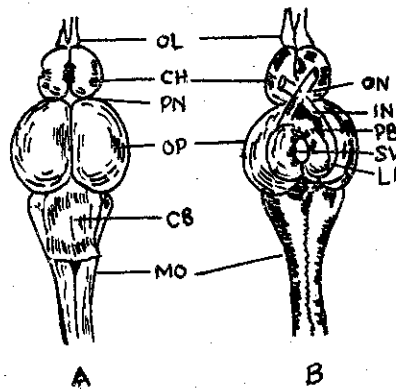

Fig 3.4 BRAIN

#### 1. DORSAL VIEW; 2. VENTRAL VIEW

CB, cerebellum; CH, cerebral hemisphere; IN, infundibulum; LI lobes inferioris; MO, medulla oblongata; OL, olfactory lobe; ON, optic nerve; OP, optic lobes; PB, pituitary body; PN, pineal body; SV, Saccus vasculosus.

This is divisible into five regions as proencephalon, Diencephalon, Mesencephalon, Metencephalon, and Myelencephalon.

**PROCENCEPHALON:** This is the anterior most region and it consists of olfactory lobes and cerebral hemispheres.

**DIENCEPHALON:** This is the second region. This contains pineal body on the dorsal side, and pituitary gland on the ventral side.

**MESENCEPHALON:** This is the third region and it comprises of optic lobes.

**METENCEPHALON:** This is the fourth region and it consists of Cerebellum

**MYELENCEPHALON:** This is the fifth region, and it consists of Medulla Oblongata.

**SPINAL CORD:** This is continuation of the brain and is a hollow nervous cord. It runs all through the length of the body on the dorsal side and lies inside the neural canal of the vertebral column. Thus it is well protected.

#### **PERIPHERAL NERVOUS SYSTEM:**

This consists of ten pairs of cranial nerves arising out of brain and a large number of paired spinal nerves arising from spinal cord.

**CRANIAL NERVES:** Ten pairs of cranial nerves arise from brain as given below:

1. **OLFACTORY NERVES:** These are sensory nerves. Their fibres pass from olfactory capsules to the olfactory lobes.

2. **OPTIC NERVES:** These nerves are also sensory. They arise from the Ventral surface of the Diencephalon and are distributed over retina.

3. **OCULOMOTOR NERVES:** These are motor nerves. They arise from the ventral surface of the midbrain and innervate the superior, inferior and internal recti muscles and the inferior oblique muscles of the eye ball.

4. **TROCHLEAR OR PATHETIC NERVES:** These are also motor nerves. They arise from the dorsal surface of the midbrain between the optic lobe and the cerebellum. They innervate the superior oblique muscles.

5. **TRIGEMINAL NERVES:** These are mixed nerves (i.e., partly sensory and partly motor). These are large nerves. Each one is having four branches, namely, ophthalmicus superficialis, ophthalmicus profundus, Maxillaria and the Mandibularia. The first two are sensory and they innervate the skin of the snout whereas the last two are mixed nerves. They innervate Maxilla and Mandibular regions.

6. **ABDUCENS:** These are motor nerves. They arise from medulla oblongata and innervate the external rectus muscle of the eye- ball.

7. **FACIAL NERVES:** These are mixed nerves, and having several branches and they innervate the lateral-line sense organs.

8. **AUDITORY NERVES:** These are sensory nerves. They arise from auditory capsule and innervate the ear.

9. **GLOSSOPHARYNGEAL NERVES:** These are mixed nerves. They arise from medulla. It innervates the first gillclefts.

10. **VAGUS NERVES:** These arise from medulla. And each one is divided into three main branches as branchial, supplying 2nd, 3rd and 4th gills, lateral, supplying lateral line, and visceral supplying dorsal muscles, stomach, intestine and heart.

**SPINAL NERVES:** There will be many pairs of spinal nerves and they supply to all visceral organs.

**AUTONOMIC NERVOUS SYSTEM:** This consists of sympathetic and parasympathetic nerve fibres and glia. They all will be connected with spinal nerves and innervate all visceral organs.

### 3.6 URINO GENERAL SYSTEM

The kidneys are mesonepharic and they lie dorsal to the air- bladder and ventral to the vertebral

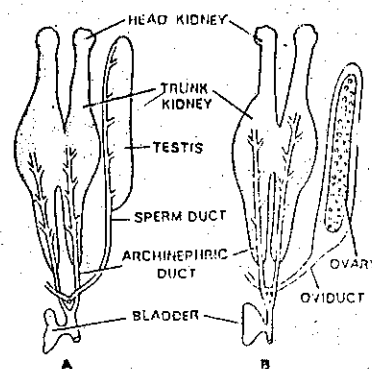

Fig. 3.5 Urinogenital organs. A-Male; B-Female.

column. They are fused behind. The anterior part of the kidney is non-renal in function, whereas its posterior part is excretory in function. The two ureters unite into a single tube which will be dilated into a urinary bladder near the urinogenital sinus, which opens to the outside.

**MALE REPRODUCTIVE SYSTEM:** In the male there are two elongated testes, extending on either side of the posterior part of body cavity. From each testis arises Vas deferences. And the two Vasa deferentia join behind to form a common duct which opens into the urinogenital sinus.

**FEMALE REPRODUCTIVE SYSTEM:** The female fish has a pair of ovaries which are compact massive sacs lying in the posterior part of the body cavity. The ovarian sacs are continued as oviducts, which open into the urinogenital sinus.

Both ova and sperms are discharged into the water and fertilization takes place outside the body of the animal. The eggs contain a large amount of yolk.

### Check Your Progress

1. The pharynx of a fish is perforated at its sides by \_\_\_\_\_ pairs of \_\_\_\_\_.
2. Tubular processes called \_\_\_\_\_ are \_\_\_\_\_. These are characteristic of \_\_\_\_\_.
3. Central Nervous system is well developed in \_\_\_\_\_ fishes.
4. In fishes sexes are \_\_\_\_\_ and Fertilization is \_\_\_\_\_.

---

### 3.7 SUMMARY

---

The digestive, respiratory, nervous and urinogenital systems are well developed in a bony fish. All these systems are inter connected and play a vital role in the life of a fish. A fish can grow hale and healthy only when all its metabolic activities are normal and its systems function well. That is why one should know in detail about all its systems.

---

### 3.8 CHECK YOUR PROGRESS : MODEL ANSWERS

---

1. Four, gill slits.
2. Pyloric Caeca, Duodenum
3. Teleost
4. Separate, External

---

### 3.9 MODEL EXAMINATION QUESTIONS

---

1. Describe the digestive system of the bony fish
2. Write an account of the mechanism of respiration in fish
3. Describe the brain of a bony fish with labelled diagram.
4. Write an account of urinogenital system in a bony fish.

---

# UNIT - 4 INTRODUCTION TO FISH CULTURE, HISTORY, PRESENT STATUS AND FISHERY RESOURCES

---

## Contents

- 4.1 Objectives
- 4.2 Introduction
- 4.3 Role of Fish Culture
- 4.4 Historical Background
- 4.5 Capture and Culture Fisheries
- 4.6 Aquaculture
- 4.7 Present Status
- 4.8 Fishery Resources of India
- 4.9 Fishery Resources of Andhra Pradesh
- 4.10 Fish Production
- 4.11 Important Aquaculture Technologies Developed in India
- 4.12 Requirements for the Development of Aquaculture
- 4.13 Summary
- 4.14 Check Your Progress - Model Answers
- 4.15 Model Examination Questions

---

## 4.1 OBJECTIVES

---

This Unit deals with the role of Fish culture, its historical background and patterns of development. At the end of this unit you will be in a position to:

- define Aquaculture and its types and present status,
- know about the fishery resources, production, and some significant aquaculture technologies developed in India.

---

## 4.2 INTRODUCTION

---

Fish culture improves the nutritional standards of the people. It generates income and employment opportunities. Fish occupies an important place in Indian mythology, history and tradition. Fish culture is an ancient practice in India. Fish culture is appropriately redesignated recently as 'Aquaculture' to indicate the farming of a variety of aquatic organisms such as prawns, molluscs, sea weeds, algae in addition to fishes. Aquaculture in India has become an integral part in rural development. Fresh, brackish and marine water resources of India and Andhra Pradesh are vast and varied. India is foremost in the world prawn production. In inland fish production, India occupies the second position in the world. In total fish production from inland and marine sources, India is ranked eighth in the world. Total fish production of Andhra Pradesh was 0.237 million tonnes in 1980. Significant aquaculture technologies developed in India are the induced

breeding of cultivated craps to produce quality seed, composite fish culture, brackish water prawn and fish farming, controlled spawning of prawns, and mollusc culture systems including techniques for production of cultured pearls. Organized research, trained personnel, extension programmes infrastructure and financial assistance to entrepreneurs are pre-requisites for the rapid development of aquaculture in the country.

---

### 4.3 ROLE OF FISH CULTURE

---

Fish is a rich source of animal protein and fish culture is an efficient protein food production system from aquatic environment. The main role of fish culture is its contribution in improving the nutritional standards of the people. In addition, it generates income and promotes employment opportunities.

Fish culture helps in utilizing water and land resources which otherwise would have remained unproductive. Fish farming is suitable for self-employment and it creates alternative employment to the people in rural areas who are seasonally unemployed. It provides inducement to establish other subsidiary industries.

It represents the production of aquatic wealth and propagation of fish culture is of great significance to India.

---

### 4.4 HISTORICAL BACKGROUND

---

Fish occupies an important place in Indian mythology, history and tradition. One of the incarnations of God in Indian mythology was in the form of fish 'Matsyavathara'. Profuse reference to fish are available in the great epics of the country. Fish remains, indicative of their use as food by the people, were obtained in excavations at Mohenjodaro and Harappa of Indus Valley Civilization (2500 B.C.-1500 B.C.). Songs of the Sangam Age (1st -4th Century A.D.) refer to the fishes, their trade and the fishermen community. Traditionally in India, fishing has been the principal avocation for the livelihood of a segment of the population-'fishermen' - living on the banks of rivers, lakes and in the coastal region.

The people of Egypt were probably the first in the world to culture fish (2500 B.C.). Fish farming was widespread in China since 2000 B.C. In India fish culture is an ancient practice. Fish culture in reservoirs was mentioned in Arthashastra (about 300 B.C.) by Kautilya. Methods of fattening the fish in ponds were described by King Somewara in Manasoltara (1127 A.D.). Traditional pond fish culture existing in the eastern states of India particularly Bengal, Bihar and Orissa, has gradually spread to other regions by the end of the 19th Century.

In spite of its distinct tradition, fish culture in India received scant attention. Concerted efforts to promote fish culture, and organized researches on culture systems were initiated only after Independence of the country. Later on, the five year plans began to cater to the specific needs of fish culture.

Important events that took place in the history of fisheries in India were the enactment of 'Indian Fisheries Act,' 1897, and declaration of Exclusive Economic Zone (EEZ) in the open seas upto 200 nautical miles, through an act of Parliament in 1976. The Indian fisheries act delegated the responsibility of development, management and conservation of fishery resources to the states. Declaration of EEZ by India to explore, exploit, manage and conserve the living and nonliving resources (fish, minerals, oil etc) from her seas, is providing vast opportunities for development of fishing and farming in a big way.

The history of fish culture shows that it originated and developed under different social and economic conditions. In India and China, pond culture was undertaken to produce an essential item in the peoples' diet. Brackish water culture was developed in some parts of India as a stage in land reclamation which involved raising the land level for agricultural purposes.

In Thailand, brackish water culture was originated as a multiple use of salt pans. In Indonesia, it was started by convicts who were forbidden to practice other professions. Fish culture in Europe began mainly in association with monasteries. In Africa, fish culture was initiated by colonial administrations to improve the nutrition of the natives. In North America, fish culture was developed since the start of this century with the main emphasis on the production of sport fishes.

In spite of such clear differences in patterns of development, present day interest in fish culture has a common orientation towards the establishment of viable enterprises irrespective of social and economic differences. A new 'fish farmer' community comprising various cross sections of the society is coming up in India, with the adoption of fish culture as its main or subsidiary avocation. Low lying lands are being converted into fish ponds and fallow coastal areas which were considered earlier as waste lands are fast becoming valuable prawn farming centres.

---

#### 4.5 CAPTURE AND CULTURE FISHERIES

---

Fisheries can be categorised into two types viz., capture fisheries and culture fisheries. Capture fisheries comprise the exploitation of aquatic organisms without stocking the seed. Recruitment of the species occur naturally. Capture fisheries is carried out in the seas, rivers, estuaries, large lakes and reservoirs.

In culture fisheries, the seed, is stocked, nursed and reared in confined waters and then the crop is harvested. The main principle of culture fisheries is to achieve sustained higher yield from a unit of water-spread area. Culture fisheries is conducted in ponds, tanks and other enclosures which are fertilized and supplementary feeds are provided to the cultivated organisms.

In capture fisheries, yield decreases with steady increase of fishing pressure. Overfishing destroys the fish stocks. Pollution and various environmental factors are causing fluctuations in the yield. Capture fisheries require huge investments and with increasing energy costs it is becoming more expensive.

In order to overcome these difficulties and to increase production, considerable attention is being given to the culture fisheries. Comparatively low capital investment, intensive nature of the culture operations, and the fact that it could be developed as a cottage industry for large scale adoption point to the advantages of culture fisheries.

Culture fisheries is conducted in fresh, brackish and marine waters. Fishes constitute the majority of the organisms cultured. With the development and expansion of a new culture systems in coastal and marine waters, farming of a wide variety of aquatic organisms such as prawns, molluscs, sea weeds and other algae have come under the domain of culture fisheries. To indicate the farming of a variety of aquatic organisms, culture fisheries recently has been assigned a more comprehensive name "Aquaculture."

---

#### 4.6 AQUACULTURE

---

Aquaculture is defined as propagation of aquatic organisms by controlling atleast one stage of the aquatic organisms life before harvest, for the purpose of increasing its production.

Aquaculture conducted in freshwater is known as 'Fresh water aquaculture', in brackish water as 'coastal aquaculture', and farming in the sea is termed 'Mariculture'. Aquaculture includes the culture of aquatic organisms for food production, culture to improve the natural stocks, culture of sport fish, culture of ornamental fish, integrated organic waste recycling systems, and culture of organisms for industrial purposes such as pearls.

There are four general types of aquaculture. The first type is to raise the seed in hatcheries for releasing them into the sea, lakes or reservoirs with expectation that natural stocks will be

supplemented and commercial catches improved. The United States, and Canada produce a large number of salmon, cod fingerlings and release them into the sea. Controlled stocking of lakes with major carp fingerlings was attempted in India, and in U.S.S.R. Stocking of lakes and reservoirs is regularly practiced resulting in increased fish yield.

The second kind of aquaculture involves the capture of young ones from natural sources and then culturing them in confinement with fertilization and feeding. Brackish water fish and prawn culture, Oyster and mussel culture, presently followed in India, belongs to this category.

The third type of aquaculture involves raising of the young from eggs obtained from wild parents, and then rearing the young ones, until they reach marketable size. Japanese shrimp culture is an example of this kind of aquaculture.

The last and most sophisticated method involves the maintenance of brood stock, production of eggs and young ones, and raising of young ones until they attain harvestable size under controlled conditions. Major carps culture, extensively followed in the fresh water ponds in India, belongs to this category.

---

#### 4.7 PRESENT STATUS

---

Finfish and shellfish are good sources of animal protein and are adequate as the principal sources of dietary protein. Fish contains protein 15-25% with essential amino acids, and mineral matter 1-2%. Fish is a good source of Vitamins-A, D and B-Complex. Fish proteins occupy an important place in human nutrition, as they have high digestibility, biological value and growth promoting value. Prawns contain 17.8% and molluscs 13% protein. About 56% of the people in India eat fish. However per capita consumption of fish in India is low. It is only 4.13 kg, per annum, while per capita requirement has been estimated to be about 11kg.

Recent estimates indicate that the total world production by aquaculture is over 5 million tonnes, of which fish production is 3.7 million tonnes. The present aquaculture production is playing an important role in the food and nutrition of many countries. In China, for example it constitutes 40% of the finfish and shellfish produced. In India it accounts for about 38% of the total fish production. In Indonesia, it forms about 22% of the total catches landed. Considering the area available for aquaculture in the world, it is suggested that production through aquaculture can be increased to 20-25 million tonnes annually.

According to an analysis, increasing world population by the year 2000, even at the present rate of consumption, would require about 100 million tonnes of fish. However, the world fish production has remained at a relatively stable level of about 75 million tonnes. It is believed that the required quantity of fish can not be met by increased catches from wild stocks. The recent trend, therefore is to turn to aquaculture as a means of complementing the production from commercial capture fisheries.

Another significant aspect of aquaculture is that it can be developed and managed, to meet the national requirement, for local consumption and for export in freshwater, estuarine and coastal areas located within the national jurisdiction. International conflicts are rather minimum with regard to rights and ownership in culture fisheries.

Aquaculture operations can be programmed to meet off-season demands. Thus it can contribute to the stabilization of market conditions. Through aquaculture, fish can be grown to the size preferred by the consumers.

Techniques of aquaculture are expanding rapidly. With the development of new techniques aquaculture is sometimes referred to as 'three dimensional' culture in which the entire water column is utilized for production.

Aquaculture has become an integral part of rural development. Fish culture is being given importance in all the rural community development schemes and applied nutrition programmes in India.

Government agencies and financial institutions are providing assistance to the entrepreneurs in rural and coastal areas. Aquaculture paves the way to combine aquafarming with agriculture, cattle, piggery, poultry and duckery systems. Integrated aquaculture-agriculture-animal husbandry systems have demonstrated that these systems are simple, easily understood by the farmers and make a substantial contribution in improving the farmers' earnings.

Aquaculture systems can be conducted from small-scale to commercial level operations generating new job opportunities. Manpower requirements vary with the type of culture techniques adopted. It is estimated that composite fish culture technology of carps if adopted in 0.6 million hectares of presently cultured freshwater in India has the capability to 0.43 million persons annually.

---

#### **4.8. FISHERY RESOURCES OF INDIA**

---

Fresh and brackish waters constitute the inland aquatic resources. The ocean and seas around the country comprise the marine resources of India.

Freshwater resources of the country are vast and varied such as rivers, tributaries, riverlets, streams, reservoirs, lakes, canals, tanks and ponds.

The rivers of India are broadly classified into the Ganga system, Brahmaputra system, Indus system, Peninsular East Coast system and West Coast system. The Ganga, the Brahmaputra and the Indus are the Himalayan riverine systems. They are perennial and fed by the melting of snow. The East Coast system of peninsular India consists of the Mahanadi, Godavari, Krishna and Cauvery rivers. The West coast system includes Narmada, Tapi and other small rivers. The rivers of the East and West Coast systems are rain fed. The Ganga riverine system is the largest in India. The riverine system in the plains is characterized by the occurrence of warm water fisheries and those in the high altitude by cold water fisheries. The total length of the major rivers and their tributaries is about 29, 000 Kilometers.

Reservoirs are the impoundments on the rivers, and nearly 3 million hectares of water spread, is available in this way.

About 1.6 million hectares of culturable freshwater in the form of tanks and ponds exist in India, of which 0.6 million hectares are currently utilized and 0.4 million hectares are readily available. The remaining water area needs reclamation.

Brackishwater resources of India are the estuaries, creeks, lagoons, backwaters, bheries, saline swamps and lakes. Total extent of brackish water areas in the country is 2 million hectares. The major estuarine systems in India are the Hooghly- Matlah estuary of the river Ganga in west Bengal, the Mahandi estuary in Orissa, the Godavari and Krishna estuaries in Andhra Pradesh. The cauvery estuary in Tamilnadu and the Narmada and Tapi estuaries in Gujarat. Important brackish water lakes are the Chilka in Orissa, and Pulicat in Andhra Pradesh and Tamilnadu.

India has a long coastline of 6100 Kilometers. The continental shelf area upto 200 meters is 4, 14, 868 Sq. Kilometers. The Exclusive Economic Zone covers 2 million Sq. Kilometers of ocean surface.

---

#### **4.9 FISHERY RESOURCES OF ANDHRA PRADESH**

---

Andhra Pradesh is a maritime state situated along the east coast, in the southern part of India. It is bordered by the Bay of Bengal in the East. The Godavari, Krishna and Pennar are the major rivers in the state draining into the Bay of Bengal. The river Godavari is the second largest river in the Indian Union. It flows in a south-eastern direction for about 1500 Kilometers.

About 114 major and minor reservoirs and lakes are present, among which prominent are the Nagarjunasagar, Tungabhadra, Srisailem, Sriramsagar, Koisagar and Kinnarsani reservoirs. Kolleru lake, one of the largest natural freshwater lakes in the country is located in the Krishna

and West Godavari districts. Construction of river valley projects in the state resulted in a well developed net work of canals and drains.

There are 45, 528 perennial and seasonal tanks in the states. According to an estimate 0.3772 million hectares of freshwater areas are available in Andhra Pradesh.

Brackish water resources in Andhra Pradesh include open estuaries, tidal creeks, canals, flats, and saline swamps. These resources cover about 0.2 million hectares. In a survey conducted by the Fisheries department, the Government of Andhra Pradesh has indicated 64, 000 hectares of potential brackish water areas, of which 17, 000 hectares could be immediately developed for coastal aquaculture.

Andhra Pradesh has a 942 Kilometers long coastline. The Continental shelf area upto 200 meters depth is 31, 044 Sq. Kilometers.

---

#### **4.10 FISH PRODUCTION**

---

The world total annual fish production rose from 21.1 million tonnes in 1950 to 73.5 million tonnes in 1976. During the past few years, world production was stabilized near about 75 million tonnes (1982). Japan is first among the fish producing countries of the world.

India's total fish production was 0.817 million tonnes in 1950. It increased to 2.4 million tonnes in 1976. India's rank in the world fish producing countries varied between seventh and ninth position, standing eighth at present. Inland fish production contributed about 0.75 million tonnes in the total fish production of India. In inland fish production, India ranked second in the world.

Prawn production in India was 0.232 million tonnes in 1977. India is foremost in the world prawn production.

India exported 78, 175 tonnes valuing Rs. 361.36 crores of marine products exported are frozen prawns, lobster tails, frog legs, cuttle fish and dried fish. Frozen prawns continue to have a dominant share in India's marine products export. About 55, 000 tonnes of frozen prawns were exported by the country during 1982- 83. India exports the marine products mainly to Japan, U.S.A., France, Netherlands, Singapore, Hongkong, Australia, Kuwait, Sri Lanka, and Mauritius.

Total fish production of Andhra Pradesh was 0.237 million tonnes in 1980, out of which about 0.116 million tonnes (48.7%) from marine waters, and about 0.121 million tonnes from inland water were produced. Andhra Pradesh accounted for about 8.8 to 10.8% of India's total production during the last five years. The total prawn production of Andhra Pradesh was 12, 100 tonnes in 1977. During 1980, the prawn production of the state declined to 11, 300 tonnes.

---

#### **4.11 IMPORTANT AQUACULTURE TECHNOLOGIES DEVELOPED IN INDIA**

---

Significant scientific developments have taken place in the field of aquaculture mainly due to the researches conducted by the central Inland Fisheries Research Institute, Barrackpore, Central Marine Fisheries Education, Bombay (Indian Council of Agricultural Research), Agricultural Universities and Fisheries Departments of various state governments.

Achievements in freshwater aquaculture in India include the production of quality fish seed of cultivated carps by induced breeding through administration of fish pituitary hormone, designing and setting up of indoor hatchery systems; standardization of nursery and rearing ponds management methodologies; transportation of fish seed to long distances, in oxygen packing; development of composite fish culture technology of Indian major carps and exotic carps which

increased the fish production in ponds to 10, 000 k.g. per hectare per year, methods of integrating fish culture with agriculture, pig and duck rearing; culture of air-breathing fishes; testing of recirculatory and cage culture systems and culture as well as breeding of freshwater prawns.

Researches on coastal aquaculture are recent. Significant developments are the brackish water prawn and fish culture; prospecting of cultivated prawn and fish seed from natural sources; successful controlled spawning of commercially important prawns; indoor prawn hatchery systems; culture of live food organisms and development of compound feeds to rear prawn larvae, and pen culture of brackish water prawns and fishes.

Mariculture systems developed are the culture of edible oysters; mussel culture; clam culture, techniques for production cultured pearls and farming of pearl oysters; culture of agar and algin yielding sea weeds.

Various technologies are being evolved to utilize different ecosystems for aquaculture. Many of the systems have been tested extensively and they are being already adopted by the fish culturists over India.

---

#### 4.12 REQUIREMENTS FOR THE DEVELOPMENT OF AQUACULTURE

---

There is an urgent need for more research on aquaculture systems to intensify culture operations to suit conditions in different regions of India. Development of low cost technologies, introduction of new species, controlled breeding of cultivated organisms for assured seed supply, nutritional aspects, hybridisation, disease control and engineering aspects of aquaculture are the major fields which need immediate attention.

Inadequate availability of finance including credit facilities is a major constraint. The present pattern of ownership and control of water bodies resting with multiple a genesis, and short term leasing policies have stood in the way of long-term development efforts by entrepreneurs.

Organisation of extension programmes is a basic requirement for success of aquaculture in the country. There is an immediate need for the trained fishery scientists, technicians and extension personnel. Education and field training facilities are to be developed

The necessary infrastructure has to be built. Storage and marketing facilities are needed to stabilize the price structure to benefit both the producer and consumer.

It is estimated that nearly 8.5 million tonnes of fish are required to feed half of India's present population. The total fish production of the country is only about 2.4 million tonnes. There is thus a huge shortage of fish in India. However, through aquaculture and by judicious utilization of aquatic resources, the requirements of India can be fully met.

#### Check Your Progress

- (1) Fish is a rich source of \_\_\_\_\_ and \_\_\_\_\_
- (2) What is an Aquaculture ?
- (3) What are the factors which help in the proper development of Aquaculture?

---

#### 4.13 SUMMARY

---

The necessity of fish culture in view of its rich protein content is explained. The historical background of the fish is given in detail. The types of capture and culture fisheries are explained. Aquaculture is also explained at length. The fishery resources of India and Andhra Pradesh are given because of the vast water bodies available in India. The fish production in the world, India Andhra Pradesh are explained.

---

#### 4.14 CHECK YOUR PROGRESS-MODEL ANSWERS

---

1. Vitamins and Proteins.
2. Aquaculture is the study of Aquatic Organisms.
3. For the proper development of Aquaculture, low cost technologies, introduction of new species, nutritional aspects, hybridisation etc. are required.

---

#### 4.15 MODEL EXAMINATION QUESTIONS

---

I. Answer the following in about 30 lines.

1. Write about the history of fish culture in India.
2. Describe the present status of aquaculture.
3. Explain the fishery resources of India and Andhra Pradesh.

II. Answer the following in about 10 lines.

1. Role of Fish culture.
2. Capture and culture fisheries.
3. Fish production of India.
4. Freshwater aquaculture technologies.
5. Requirements for aquaculture development.

BRAOU

---

# UNIT-5 SELECTION OF SPECIES FOR CULTURE, TAXONOMY AND IDENTIFICATION OF CULTIVATED FISHES AND PRAWNS

---

## Contents

- 5.1 Objectives
- 5.2 Introduction
- 5.3 Selection of Species for Culture
- 5.4 Biological Criteria
- 5.5 Economic Criteria
- 5.6 Taxonomy of Culturable Fishes
- 5.7 Taxonomy of Culturable Prawns
- 5.8 Identification of Important Culturable Prawns
- 5.9 Summary
- 5.10 Check Your Progress - Model Answers
- 5.11 Model Examination Questions

---

## 5.1 OBJECTIVES

---

This unit deals with the basic qualities required of fishes and prawns selected for culture. The taxonomic position and the identifying characters of the culturable fishes and prawns have also been dealt in the unit. After going through this unit you will know about fishes and prawns selected for culture and their taxonomic position.

---

## 5.2 INTRODUCTION

---

The criteria for selection of culturable species can be broadly divided into two viz., Biological and Economic. Biological criteria for selection of culturable species. Economic criteria for selection of culturable species. Taxonomy and systematic position of culturable fishes & prawns. There are twenty four important culturable varieties of food fishes. Eight species of culturable prawns have also been identified. Identifying characters of culturable fishes and prawns have been discussed.

---

## 5.3 SELECTION OF SPECIES FOR CULTURE

---

The aim of fish culture or prawn culture is to produce maximum quantity of fish and prawn. Though several species of fishes and prawns are available, only a few species are suitable for culture in fresh and brackish waters. Such of the species are selected which are fast growing, non-predatory and efficient converters of natural food resources of a water body, both from the point of view of production and economics. Therefore the selection of culturable species plays an important role in fish or prawn farming. In other words the production of a confined water body mainly depends on the selection of species. The criteria for selection of species can be broadly divided into two viz, Biological and Economic.

---

## 5.4 BIOLOGICAL CRITERIA

---

1. The species selected should effectively utilise food and grow fast to reach marketable sizes within the period. Therefore quick growing varieties of species should be selected.
2. There should be compatibility among the species selected for culture, intended to be stocked in the same pond. Hence species having different feeding habits and behavior should be selected to avoid serious competition among the different species.
3. The species selected should be hardy enough to withstand the fluctuations of environmental conditions such as oxygen content, pH, temperature, turbidity, etc. They should be able to survive under temporary bad water conditions and hardships of transport.
4. The selected species should be resistant to various diseases.
5. They should be non-predatory.
6. The species selected should have high percentage of survival.
7. There should be high food conversion efficiency among the selected varieties of species.
8. The seed of culturable varieties of species selected should be available in sufficient quantities.
9. They should accept supplementary or artificial feed.
10. The selected varieties of species should be able to breed by the induced method of breeding.

---

## 5.5 ECONOMIC CRITERIA

---

1. The species selected should have a good market demand.
2. They should have consumer preference.
3. Regional and seasonal predominances should be taken into consideration.

---

## 5.6 TAXONOMY OF CULTURABLE FISHES

---

Class	Osteichthyes
Sub Class	Actinopterygii
Order	Gonorynchiformes
Suborder	Chanoidei
Family	Chanidae

1. *Chanos chanos* (Forsk.)  
(Milk fish)  
Marine and Estuarine

Order	Cypriniformes
Sub order	Cyprinoidei
Family	Cyprinidae

Fresh water fishes

2. *Cirrhina mrigala* (Hamilton)  
(Mrigala)
3. *Catla catla* (Hamilton)  
(Catla)
4. *Ctenopharyngodon idellus*  
(Grass carp) (Valenciennes)

		5. <i>Cyprinus carpio</i> (Var communis) (Common carp)
		6. <i>Hypophthalmichthys molitrix</i> (Silver carp) (Valenciennes)
		7. <i>Labeo calbasu</i> (Hamilton) (Kalabans or Kalhans)
		8. <i>Labeo rohita</i> (Hamilton) (Rohu)
		9. <i>Tortor</i> (Hamilton) (Mahaseer)
<b>Order</b>	<b>Siluriformes</b>	
<b>Family</b>	<b>Siluridae</b>	
		10. <i>Wallago attu</i> (Schneider) (Fresh water shark) Fresh water fishes
<b>Family</b>	<b>Saccobranchidae</b> (Heteropneustidae)	
		11. <i>Heteropneustes fossilis</i> (Bloch) (Cat fish or Singhi) Fresh water fishes
<b>Family</b>	<b>Clariidae</b>	
		12. <i>Clarias batrachus</i> (Linnaeus) (Cat fish kor Magur)
<b>Order</b>	<b>Channiformes</b>	
<b>Family</b>	<b>Channidae</b>	
		13. <i>Channa marulia</i> (Hamilton) (Giant snake headed murrel)
		14. <i>Channa punctata</i> (Bloch) (Green snake headed murrel)
		15. <i>Channa striata</i> (Bloch) (Stripped snake headed murrel)
<b>Order</b>	<b>Mugiliformes</b>	
<b>Family</b>	<b>Mugilidae</b>	
		Brackish water fishes
		16. <i>Etroplus suratensis</i> (Bloch) (Pearl spot)
		17. <i>Mugil cephalus</i> (Linnaeus) (Grey mullet) Marine fish entering brackish water and rivers
		18. <i>Mugil corsula</i> (Hamilton) (Fresh water grey mullet) Fresh water fish entering estuaries and brackish waters.
		19. <i>Mugil dussumieri</i> (Valenciennes) (Grey mullet or Parshey) Marine fish entering estuaries, migrating into fresh waters.
		20. <i>Mugil tade</i> (Forsk.) (Green-black mullet) Marine fish entering estuaries and brackish waters.

Order	Perciformes	
Family	Centropomidae	21. <i>Lates calcarifer</i> (Bloch) (Cock-up or Bhatki) Marine fish entering fresh waters.
Family	Cichlidae	22. <i>Tilapia mossambica</i> (Peters) (Tilapia or American koi) Fresh water fish occurring in estuaries.
Family	Anabantidae	23. <i>Anabas testudineus</i> (Bloch) (Climbing perch or koi)
Family	Osphronemidae	24. <i>Osphronemus goramy</i> (Lacepede) (Gouramy)

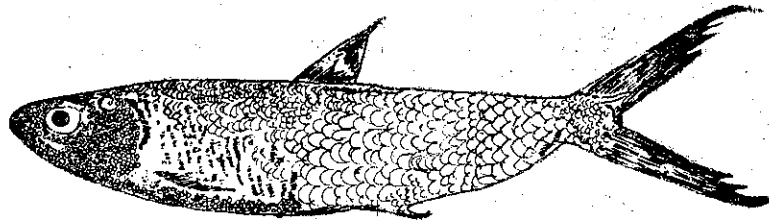

Fig. 5.1. MILK FISH (*Chanos chanos*)

1. **Chanos chanos** (Milk fish) : The milk fish is the most common species in the brackish water systems in South-east Asia. Body compressed, beautifully shaped, scales small, and toothless, single dorsal fin inserted in front of the pelvics, caudal fin prominent with subequal lobes. Body-bright silvery, greenish along the back, metallic greenish, blue on top of the head.

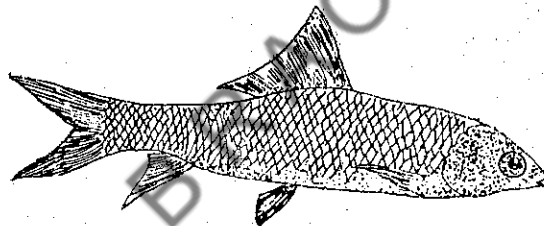

Fig. 5.2. MRIGAL (*Cirrhinus mrigala*)

2. **Cirrhina mrigala** (Mrigal) : This carp resembles *Labeo rohita* in general shape but is somewhat more slender. It has a wider mouth and thinner lips. The head is small, having a blunt snout,

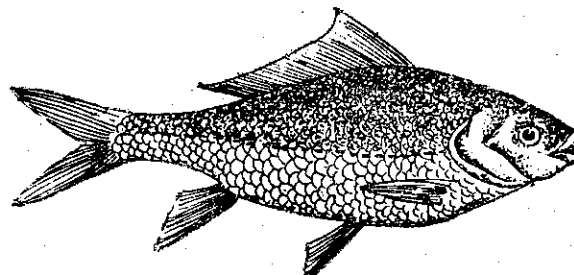

Fig. 5.3. CATLA (*Catla catla*)

with subterminal mouth and non-fringed lips. The dorsal profile is slightly more convex than the ventral profile. A single pair of short rostral barbels are present. The caudal fin is sharply forked. The dorsal fin is nearer to the snout than to the caudal base. Body silvery, dark grey along back, sometimes with coppery tinge, pectoral, ventral and anal fins orange tinged with black. Found in rivers and tanks.

3. **Catla catla (Catla)** :Body broad, deep and stout, moderately compressed, head broad, large upturned mouth, prominent lips, lips non-fringed and devoid of barbels. Thin skin covers the lower lip which has a continuous transverse fold doubling the lip outwards. Dorsal profile more convex than the ventral profile. Dorsal fin has no osseous ray. All fins are elongated. Colour greyish above silvery on sides, fins dark, sometimes black, scales with pink or coppery centre except those of ventral region which are whitish. Found in rivers.

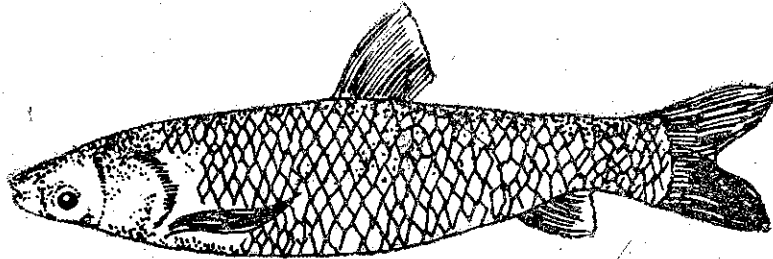

Fig. 5.4. GRASS CARP (*Ctenopharyngodon idellus*)

4. **Ctenopharyngodon idellus (Grass carp)** : Body elongated and moderately compressed. Head board with short round snout, upper jaw slightly longer than lower jaw, no barbels, short dorsal fin rays (10). Dorsal fin originates slightly in advance or opposite to that of ventral fin, scales of moderate size. Mouth is inferior. In colour it is dark grey above and silvery on the belly. It is a fresh water fish. It is an exotic fish introduced in India.

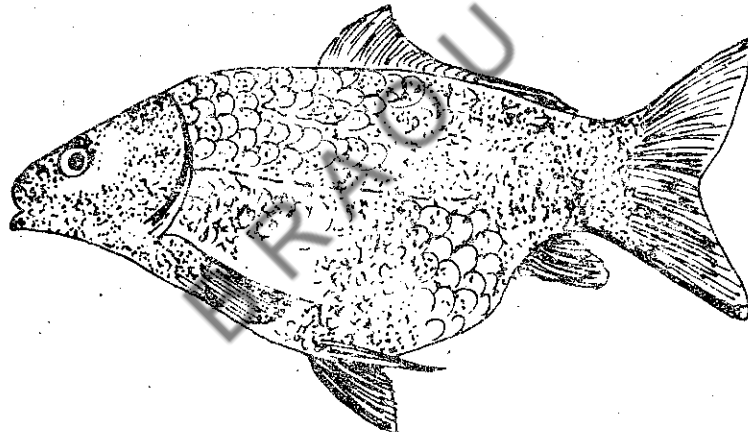

Fig. 5.5 COMMON CARP (*Cyprinus carpio*)

5. **Cyprinus carpio (Common carp)** :Head small with protrusible inferior mouth. There are

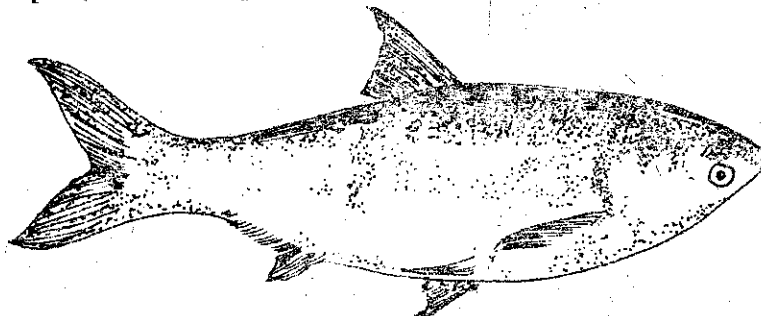

Fig. 5.6. SILVER CARP (*Hypophthalmichthys molitrix*)

two pairs of barbels. Dorsal fin has three osseous, strong, posteriorly serrated spines. Body oblong and moderately compressed. Abdomen not keeled. As the scales are a golden tinge, the fish assumes gold colour. Fins are pink. There are several varieties of common carp. But three varieties are known in India viz., Scale carp, Mirror carp and Leather carp, of which scale carp is the most widely available and Leather carp the least. It is an exotic fish introduced in India. Found in fresh waters.

6. **Hypophthalmichthys molitrix (Silver carp)** :Body oblong, slightly compressed, head pointed and broad snout bluntly rounded, lower jaw slightly protruding, small eyes, very small scales, origin of dorsal fin behind ventral fin midway between tip of snout and base of caudal. Abdomen keeled from anus to thorax, mouth superior. It has a very shining, silky, silvery white body. Found in fresh waters. It is an exotic fish introduced in India.

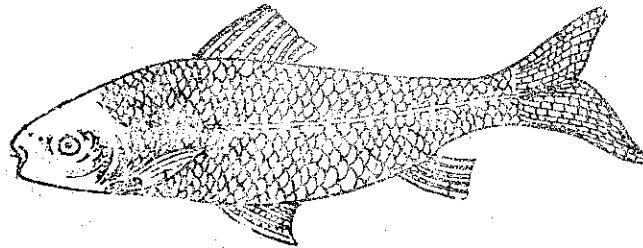

Fig. 5.7. ROHU (*Labeo rohita*)

7. **Labeo rohita (Rohu)** :Body elongated, rather roundish, head is small, mouth terminal, lips thick and fringed, dorsal profile more arched than ventral profile, barbels-a short and thin maxillary pair, rostral pair rarely present. Dorsal fin originates midway between snout and caudal base. Scales with buff, orange or reddish centre and dark margin. Bluish or brownish grey above. Fins diffusely banded grey and red or blackish. Found in fresh waters.

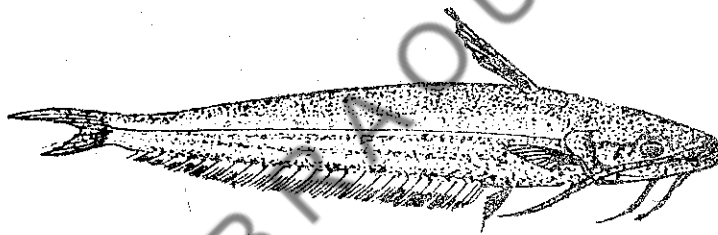

Fig. 5.8. FRESH WATER SHARK (*Wallago attu*)

8. **Wallago attu (Fresh water shark)** :It is often referred to as a 'fresh water shark' on account of its large mouth, toothed jaws and predatory habits. The body is laterally compressed with a straight back. Head is very large, trunk small and tail disproportionately long and tapering. It is found in rivers and lakes.

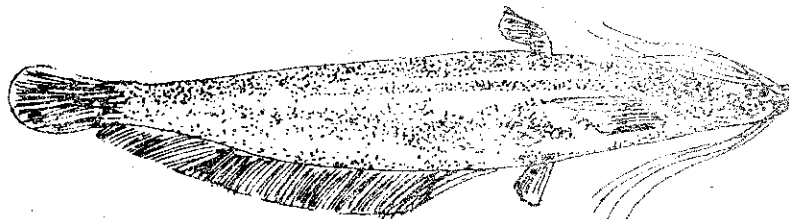

Fig. 5.9. SINGHI (*Heteropneustes fossilis*)

9. *Heteropneustes fossilis* (Cat fish or Singhi) : Head flattened, body elongated and laterally compressed. Dorsal fin short, without spine. Barbels long, four pairs. The fish is noted for its accessory air breathing organs, which are a pair of lung like sacs, arising from the gill chamber and embedded in the body muscles. It is found in estuaries and fresh waters.

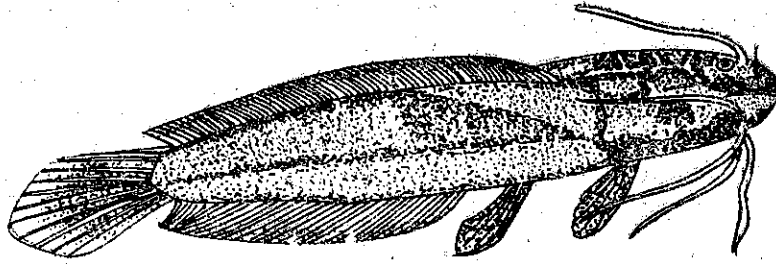

Fig. 5.10. MAGUR (*Clarias batrachus*)

10. *Clarias batrachus* (Cat fish or Magur) :Head is 5.5 times in total length of the body. There are two depressions on head, one of it situated behind the eyes and the other towards nare. There are four pairs of barbels. Maxillary pair of barbels reach middle or base of pectoral fin. Pectoral spine finely serrated. Dorsal fin is longer than anal fin and spineless. Caudal fin is free and rounded. No adipose fin. Colour uniform brown or greyish black. It is found in fresh and brackish waters.

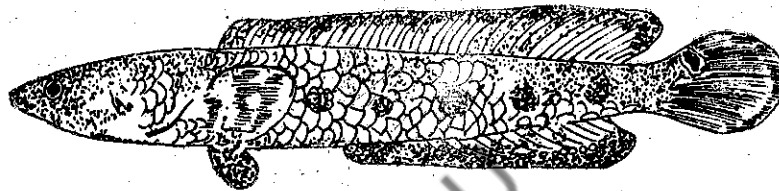

Fig. 5.11. GIANT SNAKE HEADED MURREL (*Channa marulia*)

11. *Channa marulia* (Giant snake headed murrel) :It is largest among the species of murrels. Body is cylindrical and compressed posteriorly. Length of the body is seven times the height. Cleft of the mouth extends beyond the margin of eye. Villiform teeth are present on jaws. Vomer and palatine are arranged in several rows. Colour of the back is greyish, abdomen is orange. There are black bands on lateral line, and white spots on posterior region of the body, dorsal, anal and caudal fins. Found in rivers, streams, reservoirs, tanks, etc.

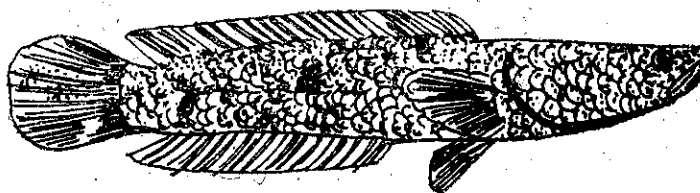

Fig. 5.12. GREEN SNAKE HEADED MURREL (*Channa punctata*)

12. *Channa punctata* (Green snake headed murrel) :Head compressed. Body cylindrical. Length is 5 to 7 times more than depth. Lower jaw longer, maxillary reaching hind border of the eye. Conical teeth are present on jaws and palat variable in colour, usually greenish brown above, yellow below, the colour may be purplish, a very dark variety covered with black spots is known. Found in stagnant fresh water bodies.

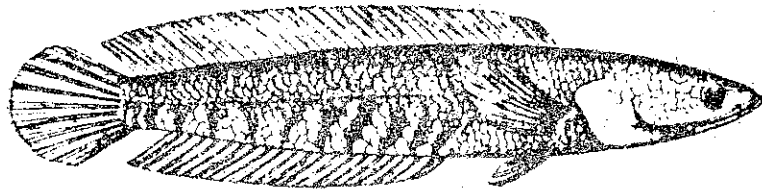

Fig. 5.13. STRIPED SNAKE HEADED MURREL (*Channa striata*)

13. *Channa striata* (Striped snake headed murrel) :The body is cylindrical and compressed posteriorly. Head compressed. The lower jaw larger. Cleft of the mouth is oblique and extends beyond the posterior margin of the eye. Teeth are present on jaws and palat. Length of the body is 6-8 times more than the height. Above the lateral line the colour is dark grey with greenish tinge or pale green and below the lateral line the dark colour is restricted by parallelly arranged vertical bands. The colour between the bands and on the vertical side is milky white, the dorsal and anal fins are slightly darker in colour than the body, dark patches on the membrane between rays. Pectorals and ventrals are pale. The caudal is dark with two distinct pale vertical bands at its base. It is found in fresh waters, prefers, stagnant muddy waters.

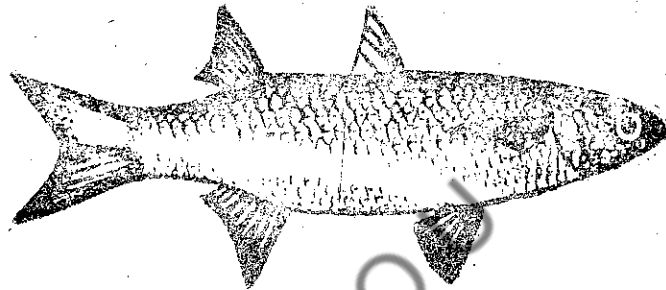

Fig. 5.14. GREY MULLET (*Mugil cephalus*)

14. *Mugil cephalus* (Grey mullet) :The head and body are covered with large scales. There are two dorsal fins. Snout rounded pectoral high, no socketted teeth in mouth, no detached finlets behind anal and 2nd dorsal fins. Found in coastal waters, migrating into estuaries and rivers.

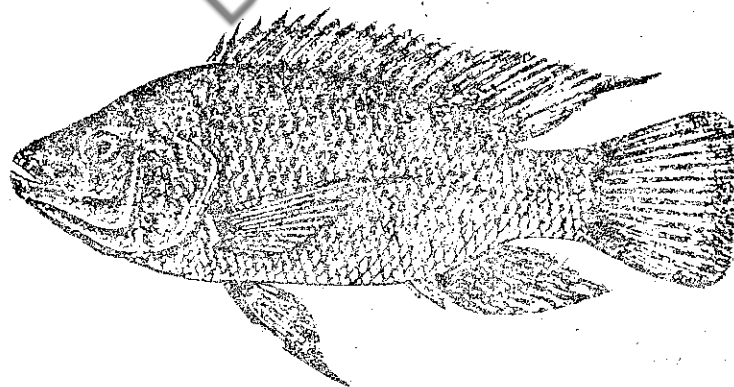

Fig. 5.15. TILAPIA (*Tilapia mossambica*)

15. *Tilapia mossambica* (Tilapia or American koi) :Body compressed. In young dark spot is present near the posterior end of the dorsal fin which may disappear in adults. This fish has

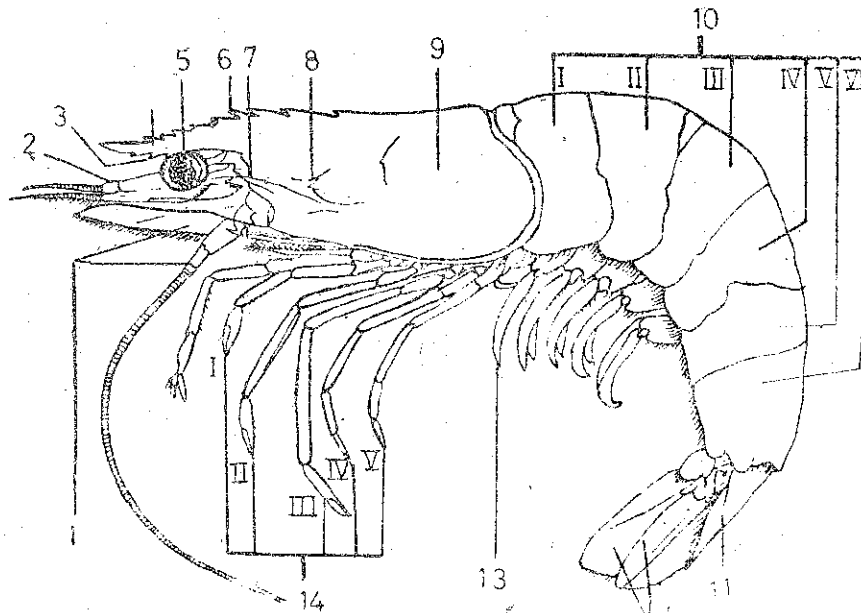

Fig. 5.19. Drawing of a prawn showing the parts of the body. 1. Antenna 2. Antennule 3. Ventral rostral spine 4. Rostrum 5. Eye 6. Dorsal rostral spine 7. Antennal spine 8. Hepatic spine 9. Carapace 10. Abdominal segments 11. Telson 12. Uropod 13. Pleopods 14. Pereiopods (1-3 Peraiopods chelate)

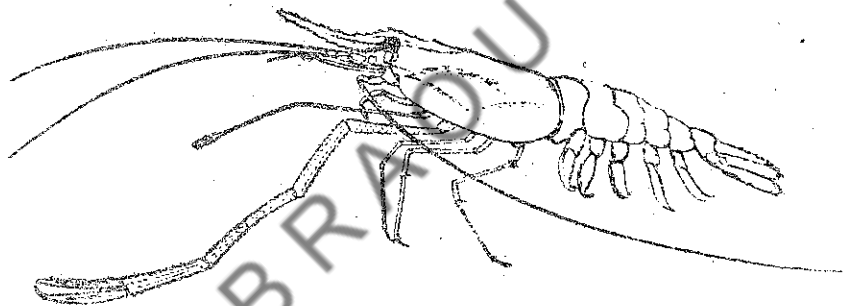

Fig. 5.20. GIANT FRESH WATER PRAWN (*Macrobrachium rosenbergii*)

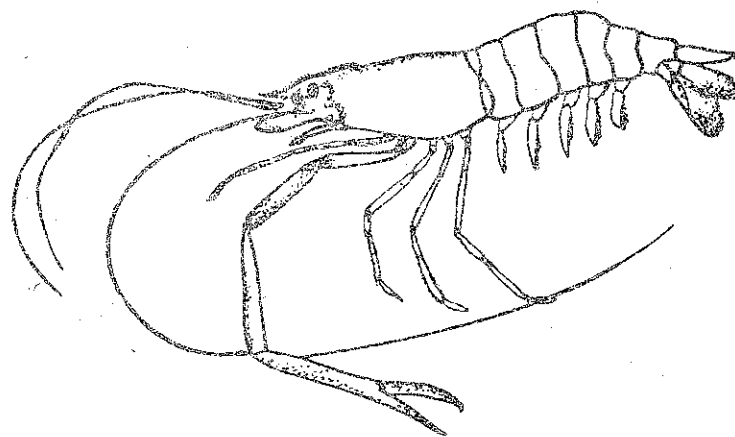

Fig. 5.21. FRESH WATER PRAWN (*macrobrachium malcolmsonii*)

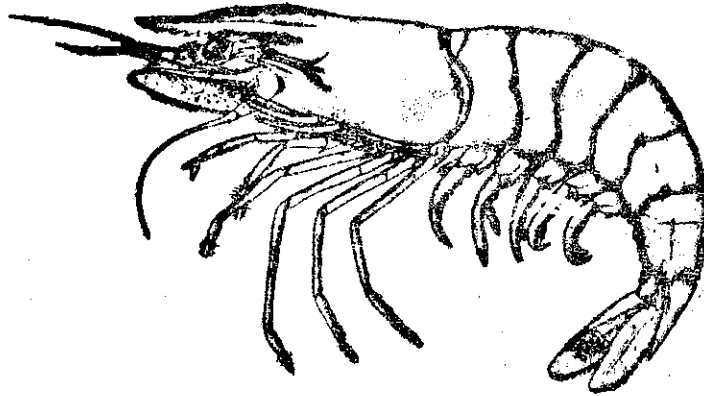

Fig. 5.22. TIGER PRAWN (*Penaeus monodon*)

spine (first spine) on the carapace. Carapace with well defined antennal and hepatic spines. The hepatic carina is horizontally straight. Gastro-orbital carina occupying the posterior 1/3 distance between post orbital margin of carapace and hepatic spine. Exopodite absent on 5th periopod. Body with transverse bands. The colour of live prawn often depends on the area of collection. Generally dark brown with emphasis on black (in estuarine or brackish waters) or reddish in clear deep waters. Antennae dark and light colour. Pleopods are brown to blue with distinct yellow bands at their bases, banded appearance on the rostrum, posterior part of telson yellow with reddish tinge consists of two lateral lobes closely meeting along the median line.

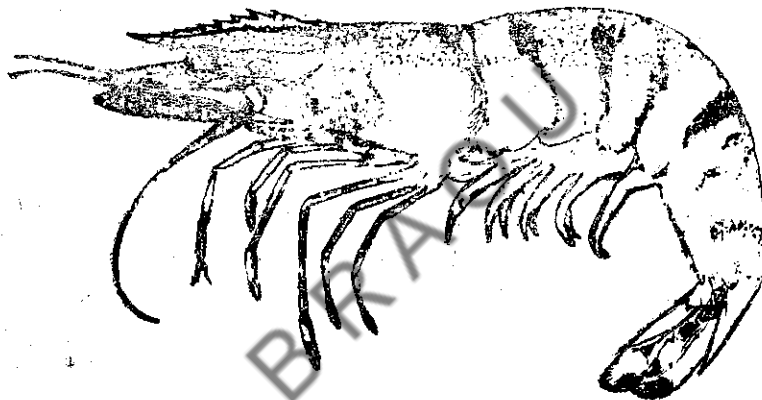

Fig. 5.23 WHITE PRAWN (*Penaeus indicus*)

4. ***Penaeus indicus* (White prawn)** :This species shows large variations in rostral length, in young forms, it is slender, elongated and surpasses the tip of antennal scale. In adults, the length is reduced and thickened at the base. It has a clear double curve with 7-9 by 4-6 teeth. The post rostral crest is not markedly elevated but is triangular in profile and faintly canaliculate. The adrostral sulcus just reaches the first rostral (epigastric) tooth and is shallow. The gastro-orbital carina is well defined. No bands on the body, the colour is creamy white with dispersed light pigmentation.
5. ***Penaeus semisulcatus* (Banded prawn)** :Carapace and abdomen uniformly smooth, rostrum straight, short as compared to *P. monodon*. The rostral formula 6-8 by 1-3 with the first (epigastric) rostral tooth on the mid dorsal surface of the carapace. The adrostral carine extends a little beyond epigastric tooth. The post rostral carine distinctly grooved. Gastro-orbital carine occupying posterior 2/3 distance between cervical sulcus and anterior margin of carapace. Hepatic carina considerably inclined anteroventrally. Exopod present on 5th

pereiopod. No external spinules on the lateral lobe of petasma. The colouration varies slightly from place to place, with an emphasis on green, the transverse bands may be red and white or pale brown with darker bands alternating, legs have reddish or yellow or pale blue colour towards ventral side.

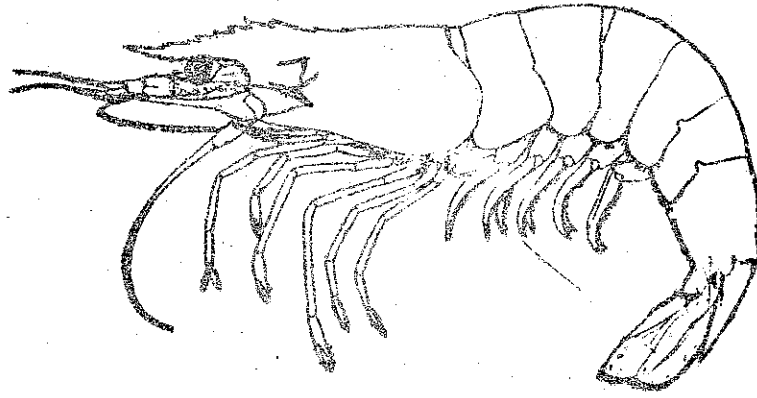

Fig. 5.24 BANDED PRAWN (*Penaeus semisulcatus*)

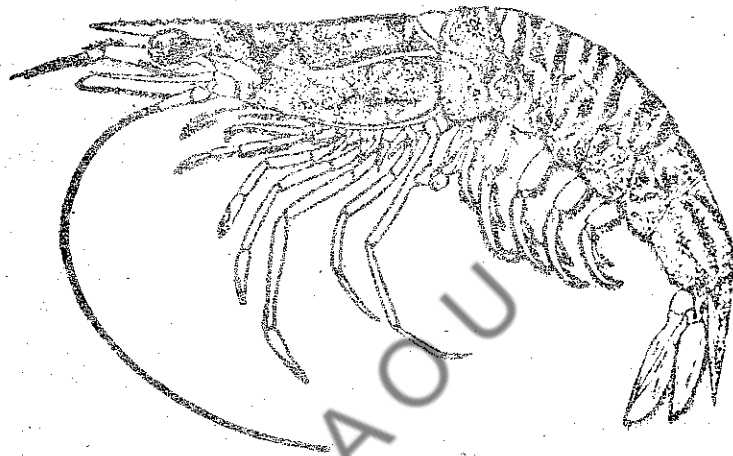

Fig. 5.25 *Metapenaeus monoceros*

6. ***Metapenaeus monoceros*** : Body covered with short tomentum, rostrum nearly straight giving a knife like appearance reaching nearly to, or a little beyond, the tip of antennular peduncle, rostral formula 9-12, post-rostral crest continues to the posterior border of carapace. The 2nd to 6th abdominal terga, usually the last also are carinated mid dorsally, the last 3 strongly so. In adult males the 5th pereiopad has the proximal end of merus notched on its outer side with a spine. No exopodite on the 5th pereiopod. Petasma with large distal lobes distally with no lateral projections. Body gives a strongly speckled appearance due to light pigmentation. General colour emphasis on body varies from grey to green.

#### Check your Progress

1. \_\_\_\_\_ is commonly known as milk Fish. It is a most common brackish water fish.
2. The Scientific name of fresh water shark is \_\_\_\_\_
3. The giant fresh water prawn is known as \_\_\_\_\_
4. The largest Indian prawn is known as \_\_\_\_\_ It' scientific name is \_\_\_\_\_

---

## 5.9 SUMMARY

---

This unit dealt with selection of fishes and prawns useful for culture. Even their biological and economical criteria are taken into consideration.

A detailed taxonomical account of both important cultivable fishes and prawns are given.

---

## 5.10 CHECK YOUR PROGRESS - MODEL ANSWERS

---

1. *Chanos Chanos*
  2. *Wallago attu*
  3. *Macrobrachium rosenburgii*
  4. Tiger Prawn, *Penaeus monodon*
- 

## 5.11 MODEL EXAMINATION QUESTIONS

---

I. Answer the following in about 30 lines :

1. Describe the criteria for selection of culturable fishes and prawns.
2. List out the important culturable fishes and prawns in confined waters.
3. Write the taxonomic position of culturable fishes and prawns.
4. Write the identifying characters of Catla, Rohu, mrigal, Common carp, Grass carp and Silver carp.
5. What are the identifying characters of *Penaeus monodon*, *P. indicus*, *Macrobrachium rosenburgii* and *M. malcolmsonii*?

II. Answer the following in about 10 lines.

Write the identifying characters of the following:

1. Milk fish
2. Fresh water shark
3. Singhi
4. Magur
5. Giant snake headed murrel
6. Tilapia
7. Pearl spot
8. Grey mullet
9. Climbing perch
10. Gouramy.

---

# UNIT-6 FOOD AND FEEDING, AGE AND GROWTH AND BREEDING HABITS OF IMPORTANT FISHES AND PRAWNS

---

## Contents

- 6.1 Objectives
- 6.2 Introduction
- 6.3 Biology of Rohu - Distribution
  - 6.3.1 Food and Feeding Habits
  - 6.3.2 Age and Growth
  - 6.3.3 Length-Weight Relationship
  - 6.3.4 Breeding Habits
- 6.4 Biology of other Cultivable Fishes
  - 6.4.1 *Chanos Chanos*
  - 6.4.2 *Channa marulius*
- 6.5 Biology of Tiger Prawn *Penaeus mondon*
- 6.6 Biology of other cultivable prawns
  - 6.5.1 *Metapenaeus monoceros*
  - 6.5.2 *Macrobrachium rosenfergii*
- 6.7 Summary
- 6.8 Check Your Progress - Model Answers
- 6.9 Model Examination Questions

---

## 6.1 OBJECTIVES

---

This unit deals with the biological aspects like food and feeding, habits, age and growth, length and weight relationship and breeding habits of important cultivable and prawns. After going through this unit you will be able to

- Define age and growth, length and weight relationship.
- describe the important Cultivable fishes and prawns.

---

## 6.2 INTRODUCTION

---

Distribution, and feeding habits, age and growth, length-weight relationship and breeding habits of rohu, *Labeo rohita* (Hamilton). Biology of other cultivated species of fishes, viz., milk fish, *Chanos chanos* (Forsk.) and *Channa marulius* Hamilton-Buchanan. Biology of tiger prawn, *Penaeus monodon* (Fabricius). Biology of other cultivated prawns monoceros (Fabricius) and *Macrobrachium rosenfergii* (de Man).

### 6.3. BIOLOGY OF ROHU, *Labeo rohita* (Hamilton) DISTRIBUTION

This fish is common in the plains of Northern India. However, because of successful transplantations carried out since the beginning of the 20th century and the wanderings of the fish aided by the occurrence of extensive canal systems, rohu has now spread over the whole of Peninsular India.

#### 6.3.1 Food and Feeding Habits

Rohu fry start feeding on plankton from the 5th day after hatching. A strong positive selection was observed for all the zoo planktonic organisms and for smaller phytoplankters like desmids, *Cosmarium* and *Closterlum*, Phytoflagellates like *Euglena* and *Volvox* and algal species and *zygotes*.

The food consists of vegetable debris, animalcules, water fleas and sand or mud upto 20 mm. length of the juveniles. From 20mm. length onwards rohu feeds on unicellular and filamentous algae also. The zoo planktonic organisms consumed include cladocerans, copepods, insect larvae, rotifers and nauplii. Among crustaceans there is a strong preference for *Cyclops* and among rotifers, *Keratella* is consumed heavily. In the case of adults, phytoplankton is preferred over zooplankton.

The fish mainly feeds on mid surface waters although it explores other zones of environment. The nibbling type of mouth with soft fringed lips, sharp cutting edges and absence of teeth in buccopharyngeal region indicate that this fish subsists on soft aquatic vegetations which do not require seizure or crushing.

The intensity of feeding is high throughout in the juveniles. Feeding intensity of adults is affected by maturation and spawning. The maturing fishes showed considerable increase in the feeding intensity. Mature fishes show a slackening in feeding. Spent fishes again feed actively. This increase and decrease in feeding is more prominent in the females than in the males. Males exhibit better feeding than females during spawning months and on the whole feeding is better in the males throughout the year than the females. However, the females feed more actively during post-spawning months than the males.

#### 6.3.2 Age and Growth

The age of rohu is determined from its scales. The scales of rohu showed growth rings in the form of carved out grooved rings which are found to be annular and hence suitable for age determination. Rohu was found to attain an average length of 310 mm, 500 mm, 650 mm, 800 mm, 850 mm, 890 mm, 920 mm, 940 mm, and 960 mm., at the end of the first to the tenth year of life. Thus the growth increment was 310 mm., 190 mm., 150 mm., 90 mm., 60 mm., 50 mm., 40 mm., 30 mm., 20 mm., and 20 mm., at the end of the first to the tenth year of life respectively.

The seasonal growth of *L. rohita* is very much influenced by the feeding intensity and spawning cycle of the fish. Ecological factors of the water like conductivity, alkalinity and temperature also have an influence on the growth of *L. rohita*.

#### 6.3.3 Length Weight-relationship

The length-weight relationship in this fish can be expressed by the equation :

$$\text{Weight} = C \cdot \text{length}^n$$

In which 'C' is a constant and 'n' is for coefficient of growth rate.

The increase in weight in relation to length is not appreciable upto 150 mm. length. It is conspicuous between 150-200 mm. length and well marked above 200 mm. length. Females are

heavier than males upto the length of 500 mm., and males were heavier than females at higher length.

The growth of rohu spawn was influenced by the qualitative difference in food supply, such as the type of zooplankton and algae present in the pond. Growth and survival of spawn when stocked in nurseries depend on the kind and dose of fertilizers used, supplementary feeding and density. Inorganic fertilizers such as ammonium sulphate, urea etc., have been found to enhance the survival and growth of spawn.

#### 6.3.4 Breeding Habits

*Labeo rohita* like other major carps, breeds naturally in rivers and reservoirs and in artificially constructed bundh type tanks where fertile conditions are stimulated during the spawning season. Large-scale natural spawning occurs in flooded sections of rivers during the southwest monsoon months. Spawning grounds are located in the middle reaches of rivers where flooded water inundates vast adjoining riparian lands.

Breeding commences in the morning in rohu. The courtship is short-lived. The coiling of the two partners exerts pressure on the abundance of the mating pair, resulting in the extrusion of ova and exudation of milt. All eggs are not laid at one place and at one time, but at intervals during which the pair keeps on moving.

Fertilization is external. The fertilized eggs are abandoned by the parents. A thick blanket of eggs is left behind on the spawning sites. The spent fish swim aimlessly for a while and commence their homeward journey along with receding water. Heavy monsoon flood, capable of inundating vast shallow areas which form the breeding grounds of fish, stimulates spawning and is believed to be a primary factor responsible for spawning.

---

### 6.4 BIOLOGY OF OTHER CULTIVABLE FISHES

---

Besides the major carps, there are other species of cultivable fishes some of them are freshwater some of them are thrive in varied degree of salinity (brackishwater) and some of them are carnivorous (Cat fishes, murels etc.)

#### 6.4.1 *Chanos chanos* (Forsk.)

This is commonly known as Milk fish. It grows upto a length of 1500 mm. This is a marine and estuarine fish, suitable for cultivation in fresh and brackish water ponds. It does not mature or breed in confined waters. It spawns in the sea near the coast. Eggs pelagic, 12 mm. in diameter, embryos hatch out within 24 hours. Larvae are 12 to 15 mm. length, occurring periodically in great quantities along sandy coasts and in estuaries. In India they occur from March to August and also from October to December. Fingerlings occur in estuarine waters of South India.

Fry and fingerlings are stocked in ponds and reservoirs. Fry reach a length of 50 to 70 mm. at the end of the first month and 120 to 150 mm. at the end of the second month. It reaches an average length of 40 cm. and an average weight of 450 gm. within one year.

The fry and fingerlings feed on the phytoplankton (Bacillariophyceae, Myxophyceae and remnants of Chlorophyceae). Adults feed on diatoms, copepods, larval bivalves, fish eggs etc. In rearing ponds it feeds on the green bottom growth called "lab lab". This substance represents a biological complex consisting of decayed green and blue green algae diatoms, protozoa bacteria and detritus. When it attains upto 450 gms in weight it takes a comparatively large portion of fresh filamentous algae and parts of higher plants. In freshwater ponds and tanks *Chanos* feeds on vegetable planktonic and epiphytic organisms and on decayed macro-vegetation.

#### 6.4.2 *Channa marulius* (Hamilton Buchanan)

This fish attains a length of 1200 mm. This is also a river fish, suitable for cultivation in confined waters. It breeds in ponds. The breeding period is from April to June. Fertilized eggs measure about 1.5 mm. in diameter and are brownish in colour. Fry become independent of parental care after about six weeks. *C. marulius* feeds on small fishes, frogs, tadpoles, water insects. It has cannibalistic habits. It is a quick growing species. Two month fry measure about 12 cm.

---

### 6.5 BIOLOGY OF TIGER PRAWN, *PENAEUS MONODON*

---

This species occurs along both the coasts and more common by along the northeast coast of India. It is widely cultured in brackish waters. This species grows to a maximum size 330 mm.

The major food items are higher plant matter, algae (*Lyngbya*, *Spyrogyra*, *Chaetomorpha*, *Enteromorpha*), diatoms (*Coscinodiscus*, *Biddulphia*, *Gyrosigma*, *Chaetoceros*, *Asterionella*, *Cocconeis*, *Thalassiothrix*), Copepods (*Acartia*, *Calanus*, *Pseudodjaptonus*, *Labidocera*) Isopods Amphipods, Decapods, Gastropods (*Nassa*, *Pyrgulina*, broken shells), sand, detritus, semidigested matter, pieces of moults, fish eggs, fish scales.

The monthly growth rate of this species in natural waters is about 25-30 mm., whereas under culture conditions the observed growth is at a lower rate. In the initial months the growth rate was less (15 mm. in length and 2.5 gm in weight per month) but in the later months, more (26 mm. in length and 9 gm in weight per month). Growth is fastest in the summer medium during the monsoon and poor in winter. Lower salinity and temperature adversely effect the growth in this species.

Under pond conditions the species does not mature. As in other estuarine penaeid prawns, this species also shows catadromous migrations, i. e., the post larval forms enter the estuaries and after a period of growth the young prawns return to the sea for breeding. Two peaks are observed in the incursion of post larval prawns into the estuary : November-January and April-June. High temperature, salinity, dissolved oxygen and feeding are important parameters in inducing maturity and spawning in this species.

The fertilized egg is released directly into the water and further development follows.

---

### 6.6 BIOLOGY OF OTHER CULTIVABLE PRAWNS

---

#### 6.5.1 *Metapenaeus monoceros* (Fabricius)

This species occurs in the coastal areas and the estuaries of the southwest and West coasts of India. It attains a maximum length of 180 mm.

It mostly feeds on crustaceans, algae, foraminifera, small molluscs and organic detritus.

The growth rate ranges between 5 mm to 15 mm. per month in the different size ranges during its growth.

It attains maturity and breeds in the sea. The breeding season is in November and December. Late mysis and post larval stages of this species migrate into backwaters and estuaries all along the coastline of India.

#### 6.5.2. *Macrobrachium rosenbergii* (de Man)

This species occurs in the freshwater zones of the rivers of the East and West Coasts. Though a freshwater prawn, it migrates into the estuaries for breeding and spawns in areas where salinity fluctuates between 5 and 20‰. After the young grow into a size of 2-3 cms, they migrate up to the estuary to freshwater habitats. They attain a length of 320 mm.

The rate of growth ranges between 20 to 30 mm. per month during different stages of growth. It is an omnivorous feeder, feeding on detritus, animal and vegetable matter. It attains maturity in culture conditions, and normally breeds in estuaries. It is suitable for cultivation in ponds and tanks.

**Check Your Progress.**

1. \_\_\_\_\_ breeds in rivers and reservoirs.
2. Lab Lab

---

**6.7 SUMMARY**

---

The biology of Rohu, Chanos, (fishes) and prawns such as *Penaeus*, *Metapenaeus* are dealt in detail. Determination of Age and growth of fishes, the length-weight relationship are described.

---

**6.8 CHECK YOUR PROGRESS - MODEL ANSWERS**

---

1. *Labeo rohita*
2. The green bottom growth in rearing ponds is called "lab lab". This substance represents a biological complex consisting of decayed green and blue green algae diatoms, protozoa bacteria and detritus.

---

**6.9 MODEL EXAMINATION QUESTIONS**

---

**I. Answer the following in about 30 lines.**

1. Biology of Rohu
2. *Biology of Tiger Prawn*

**II. Answer the following in about 10 lines.**

1. Biology of Milk fish
2. Biology of *Macrobrachium rosenbergii*

---

# UNIT - 7 LIFE HISTORY AND IDENTIFICATION OF EGGS, LARVA AND JUVENILES OF CULTIVATED FISHES AND PRAWNS

---

## Contents

- 7.1 Objectives
- 7.2 Introduction
- 7.3 Life history-Eggs and Larval Stages of Rohu
- 7.4 Life History. Eggs and Larval Stages of Introduced Cultivable fishes.
  - 7.4.1 Common Carp
  - 7.4.2 Silver Carp
  - 7.4.3 Gross Carp
- 7.5 Life history Eggs and Larval stages of Murrel
- 7.6 Life history Eggs and Larval stages of Cultivable Prawns
  - 7.6.1 *Penaeus indicus*
  - 7.6.2 *Metapenaeus monoceros*
  - 7.6.3 *Metapenaeus brevicornis*
- 7.7 Summary
- 7.8 Check Your Progress - Model Answers
- 7.9 Model Examination Questions

---

## 7.1 OBJECTIVES

---

In this unit you learn about the life history, eggs, larval stages and their specific characters useful for identification of important cultivable fishes and prawns.

---

## 7.2 INTRODUCTION

---

Life history, eggs and larval stages of rohu, *Labeo rohita* (Hamilton). Life history, eggs larval stages of introduced cultivable fishes. Life history, eggs and larval stages of Murrel, *Channa punctate* (Bloch). Life history, eggs and larval stages of cultivable prawns.

---

## 7.3. LIFE-HISTORY, EGGS, AND LARVAL STAGES OF ROHU, LABEO ROHITA (Hamilton)

---

Rohu attains maturity towards the end of the second year of life. It spawns only once a year and the spawning duration is short. The spawning season of rohu generally coincides with the southwest monsoon.

Fertilization eggs of rohu are round, transparent, demersal, nonadhesive and red in colour. The yolk sphere contains no oil globule. Fully fertilized eggs are 5mm. in diameter. The newly hatched larva measures 3.5-4.5 mm. It has a transparent, laterally compressed body and is characterized by the presence of gill slits, pectoral fin and median fin fold. The yolk is gradually tapering, with a prominent anterior bulbous portion and elongated and narrow posterior blunt end, having slight pinkish hue on its, dorsal part. The hatching has faint yellowish-brown eyes and shows irregular movements occasionally coming up or otherwise lying laterally at the bottom.

Post larvae, just after absorption of yolk measure 6.5 mm. to 7.5 mm. Rudiments of dorsal, anal and pelvic fins appear on the 30th, barbels on the 21st day and liver on the day after hatching. The airbladder originates 2 1/2 days after hatching.

The characteristics of the different growth stages of rohu larva after hatching are as follows :

#### After 24 hours of hatching

Average size of larva 5.5 mm. A few black chromatophores seen on the head above eyes. Embryo pale yellow in colour. Anal distinct. Auditory concretions clear. Yolk sac sharply ending distally to a point. Striations seen in the caudal. Pectoral without rays. Notochord turned upwards only at the very end.

#### After 36 hours of hatching

Average size about 5.9 mm. Lower lip clear. Pectoral fin prominent. Anterior profile of yolk sac more or less straight. A few black chromatophores on dorsal margin of the yolk sac throughout its length, a few on the dorsal fin. No chromatophores on caudal region. Dorsal and ventral sides of embryo pale yellow in contrast to the deep yellow colour of the caudal region posterior to the anus. Notochord slightly upturned at the tip. Mouth appears as a slit.

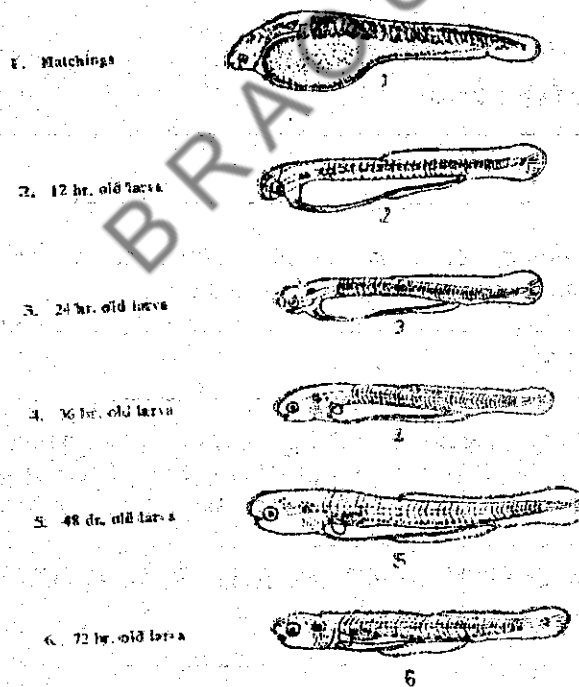

Fig. 7.1 Larval development of *Labeo rohita*

#### **After 48 hours of hatching**

Average size 6.2 mm. yolk sac convex anteriorly. Embryo yellow in colour. Air bladder distinct. Pectoral fin prominent. A few black chromatophores on the head behind the eyes and in the auditory region. No chromatophores on the ventral side of the air bladder. Black chromatophores in a row from the area posterior to the auditory concretions upto the base of the caudal fin. Large black chromatophores on head prominent. Ventral embryonic fin originates in advance of the dorsal fin fold. Head dark and body faint yellow.

#### **After 72 hours of hatching**

Average size 7 mm. Pale yellow in colour. Black chromatophores on the head with a few in between the eyes. Dorsal profile of embryo bright yellow till the anal region. Caudal region above the notochord yellow.

The characteristics of rohu post larvae after three days of hatching are as follows :

#### **4th day after hatching**

7.6 mm. in length. Yolk sac completely absorbed on the 4th day after hatching. Lip margins gently fimbriated. Distinct black chromatophores seen behind the eyes on the head region. Opercular outline distinct. Notochord bent at the tip. Crescent shaped semicircular area below notochord in the caudal region formed of black chromatophores in rows; the area of the semicircle well defined. Dorsal and ventral fin folds persistent. Commencement of caudal rays.

#### **6th day after hatching**

10-10.5 mm in length. Lower jaw bigger and upturned ; gape of the mouth 1.7 mm. Eye 1 mm. Nostrils prominent. Dorsal fin with 9 rays, anal with faint rays, pelvic fin bud seen. Air bladder divided into 2, the anterior part globular and posterior in the form of elongated triangle. Dorsal side of body yellow. Chromatophores form two crescents on the two lobes of the caudal fin separated by a small colourless area. Caudal rays 22.

#### **7th day after hatching**

11 mm. in length. Lips thick. Notochord sharply bending upward. Ventral embryonic fin fold, stretching from abdominal region upto anus; dorsal embryonic fin fold visible as far forward as opposite to the anus. Two black chromatophore clusters at the caudal peduncle and two crescent shaped patches on caudal fin; caudal fin with 22 branched rays ; caudal fin less deeply forked ; pelvic fin with 2-3 rays ; dorsal with 2-11 rays.

#### **8th day after hatching**

12.5 mm. in length. Dorsal fin with 14 rays with sparsely distributed yellow pigment near base of the rays. Anal with 7 rays. Ventral embryonic fold ending in the anal region. Caudal with 22 rays. To dark crescentic areas at the base of the caudal fin and a few black chromatophores on the embryonic fold connecting the caudal fin with the anal fin. Pelvic fin with fin rays. Body golden yellow, dorsal half more predominantly. Prominent black chromatophores on the head. Black chromatophores scattered all over the body exhibiting no pattern.

#### **12th day after hatching**

19 mm. in length. Maxillary barbels present. Body golden coloured on the dorsal side and dirty yellow ventrally. Dorsal fin with 3- 13 rays. and 1 fin with 7 rays, except for the anterior one, the rest are branched. Ventral fin with 7 rays, except two anterior ones, the rest are branched. Caudal fin rays 34, a broad triangular black band on the caudal peduncle across its entire with the apex facing the head.

1. Fourth day after hatching



2. Fifth day after hatching

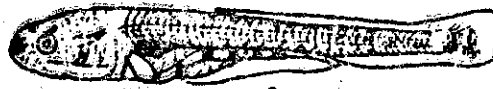

3. Sixth day after hatching



4. Seventh day after hatching



5. Tenth day after hatching

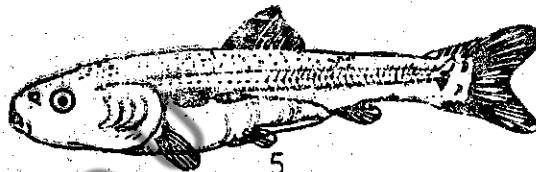

6. Fifteenth day after hatching

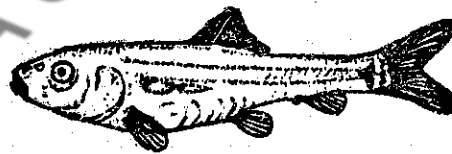

Fig. 7.2 Post-larval development of *Labeo rohita*

#### 15th day after hatching

23 mm. in length. Anal fin with 2-5 rays. Caudal rays 36. Basal  $\frac{2}{3}$  of the dorsal fin pigmented. Black chromatophore band in caudal region, posteriorly prolonged from the centre passing through the origin of caudal rays and dividing the fin into two.

#### 18th day after hatching

25 mm. in length. Body dirty yellow above lateral line and yellowish white below it. Scales present but not clear near the caudal peduncle and in the abdominal region. Black chromatophores on the anterior margin of the dorsal fin in the form of dotted line. Ventral fin with 9 rays. 32 caudal rays. Two prominent greyish crescents, one on each half of the caudal fin lobes behind the dark triangular areas on the caudal peduncle.

#### 20th day after hatching

26 mm. in length. Body golden coloured. Scales prominent and fully covering the body. Two dark bands one above and one below the lateral line along the body upto the caudal region. Dorsal fin with 3-13 ray. Caudal rays 34. Rays covered with orange pigment dots. A black band along the entire width of the caudal peduncle concave posteriorly and irregular in shape along the anterior margin. Behind this band two faint crescentic areas separated by two colourless streaks.

#### 25th day after hatching

30 mm. in length. Body golden coloured with coppery reflection from operculum. Barbels prominent. Upper margin of eye faintly orange. Dark band in caudal peduncle quite prominent. Upper lobe of caudal fin larger and pointed compared to somewhat round edge of smaller lower lobe.

---

### 7.4 LIFE HISTORY, EGGS AND LARVAL STAGES OF INTRODUCED CULTIVABLE FISHES

---

Of the exotic food fishes, the following are more important from the point of fish culture : Common Carp, *Cyprinus carpio Linnaeus*, silver carp, *Hypophthalmichthys molitrix* (Valenciennes), grass carp, *Ctenopharyngodon idella* (Valenciennes), tilapia.

#### 7.4.1 Common Carp (*Cyprinus carpio Linnaeus*)

Fertilized eggs of common carp are small, spherical, demersal and adhesive. Diameter of the developing egg varies from 1.0 to 2.0 mm. The perivitelline space surrounding the egg is narrow. Yolk is, usually yellow to light brown in colour. Embryos hatch out within 2 days to 7 days depending on the water temperature. The newly hatched out larva is 4.0-5.6 mm. in length and has a prominent yolk mass. The newly hatched out larva adheres to the leaves of aquatic plants by means of cement glands and remains in this condition until the yolk is partially absorbed. The yolk is absorbed within 2 to 6 days depending on water temperature, after which the postlarvae measuring 6-7 mm. start normal movement and commence taking nourishment from the environment. If suitable food is available the growth is rapid and fins get differentiated. Within 12 to 15 days of yolk absorption, all fins develop the full complement of rays.

#### 7.4.2. Silver Carp; *Hypophthalmichthys Molitrix*

Freely oozing viable ova of silver carp are pale bluish in colour. Fertilized eggs are demersal and round and ashy grey in colour. Within 5 minutes of fertilization, eggs start swelling and during the next half an hour, the process of water hardening is completed. The fully swollen fertilized eggs measure 4.2 to 4.76 mm. in diameter.

The length of the newly hatched larva of silver carp is 5.0 to 5.5 mm. The length of yolk sac is 3.33 mm. Height of the body 1.25 mm. Height of yolk sac 1.09 mm. Number of myotomes are 42 to 44 in number of which 14 to 16 are located behind the anal level. Yolk sac is fully absorbed by the end of the second day of hatching and, thereafter, post larvae start feeding from the environment. The post larvae measure 7.42 to 7.53 mm. in total length and 1.21 mm. in height of body.

#### 7.4.3 Grass Carp : *Ctenopharyngodon Idella*

This fish lays eggs in stages. Eggs are pelagic and undergo development as they float downstream. Ovarian eggs are of yellow and deep golden brown in colour. Fertilized eggs get fully swollen

in half an hour and measure about 4.58 mm. in diameter. Newly hatched out larva measures 4.5 to 6.0 mm. in length. Length of yolk sac 2.84 mm. Maximum height of body 2.90 mm. and maximum height of yolk sac 0.78 mm. Yolk mass is conspicuous and of a pale brown colour. Of the 45 myotomes, 14 are posterior to the anal level. Two day old post larva, just after absorption of yolk sac is 6.98 mm. in total length and 0.99 mm in maximum height of body.

---

## 7.5 LIFE HISTORY, EGGS AND LARVAL STAGES OF MURREL - CHANNA PUNCTATUS

---

Fertilized egg is round, non-adhesive, buoyant, free and straw yellow in colour. The yolk is capped by a distinct blastodisc and contains an oil globule liable to disintegration to smaller 5 to 6 globules, unequal in size. Perivitelline space is of medium width. Diameter of the egg is 1.2 mm. and that of the yolk is 0.9 mm.

The development after fertilization is as follows :

### 10 hours after Fertilization

Anteroposterior axis is distinguishable, cephalic portion being broader. Fore brain region discernible. Invasion of the yolk complete.

### 14 hours after Fertilization

The embryo with 6 somites is embedded all over its length in the yolk mass. Optic cups are clear. Height of the embryo is 1.0 mm.

### 16 hours after Fertilization

9 mesodermal somities present. Notochord is more discrete and the fore, mid and hind brain regions are also defined. Cephalic portion is broadened.

### 17 hours after Fertilization

The somites range from 13 to 15 in number. Ectodermal thickening to form lens of the eye is indicated. Tip of the tail is from the yolk at the vast somite. Embryonic fin fold appears. Kupfer's vesicle is visible. Cephalic region is depressed. Height of embryo 1.1 mm.

### 20 hours after Fertilization

22 somites. Embryonic fin fold on the ventral side extends upto the 10th somite. The lens is now fully formed in the eye. Olfactory placode indicated. Kupfer's vesicle gets diminished. Blood circulation can be seen over to yolk into the rudimentary heart lying anterior to the yolk sac. The heart beats very rapidly. Some dendritic melanophores appear over the yolk.

### 22 hours after Fertilization

Somites are 24 in number. The embryo encircles the yolk and covers practically the entire capsule. Tail is free. Olfactory pits and auditory vesicles are now well pronounced. Some melanophores appear above the neural chord, over the trunk and caudal regions. Heart beat is very rapid. Kupfer's vesicle disappears.

### 24 hours after Fertilization

Twisting movement of the embryo is vigorous and lashes the tail vigorously against the capsule, thereby springing up the head which suppresses the wall and brings the embryo out.

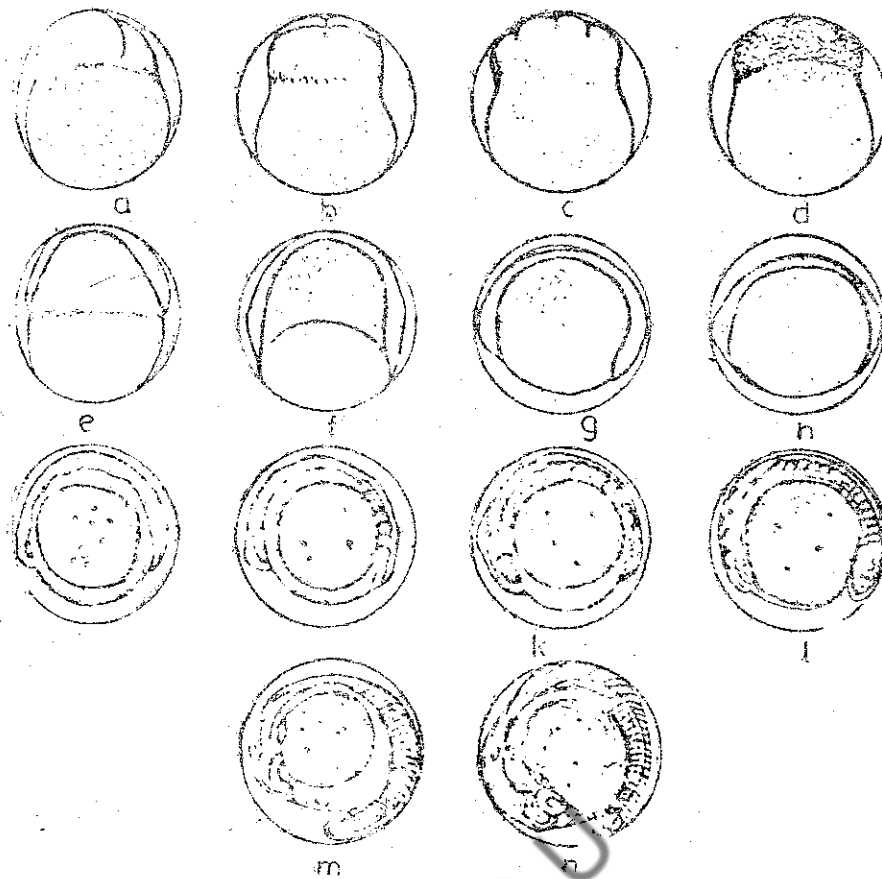

Fig. 7.3 Embryonic development of *C. punctatus*.

- |                   |                   |                   |                 |
|-------------------|-------------------|-------------------|-----------------|
| a) 2-celled stage | b) 4-celled stage | c) 8-celled stage | d) morula stage |
| e) 3 hours old    | f) 5 hours old    | g) 5 hours old    | h) 8 hours old  |
| i) 10 hours old   | j) 14 hours old   | k) 16 hours old   | l) 18 hours old |
| m) 20 hours old   | n) 22 hours old   |                   |                 |

The newly hatched larva is dull brown in colour. 2.7 mm long 1.1 mm height. The fin fold originates dorsally at the second myotome, runs ventrally the region of the vent and goes upto the yolk sac. Third and fourth ventricles of the brain are very prominent. Eight dendritic melanophores appear at the caudal region. Linear melanophores appear at the caudal region. Linear melanophores appear prominently on the lateral side of the body.

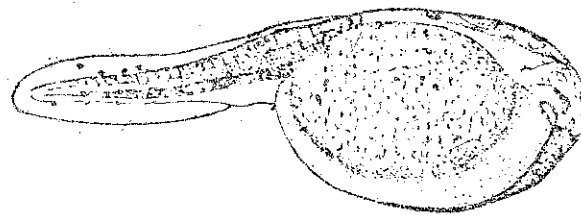

Fig. 7.4 Hatching of *C. punctatus*.

Larval development is as follows :

**3 hours after hatching**

Length 3.1 mm and height 1.4 mm. The heart is two-chambered. Circulation can be seen around the notochord in addition to the brain and yolk. Blood corpuscles are reddish yellow showing formation of haemoglobin. The anal opening is marked by a slight invagination.

**8 hours after hatching**

Length 3.5 mm. and height 1.1 mm. Myotome count is 31. Bulge of the yolk is reduced. Some more melanophores appear on the ventral side of the notochord and the dorsal side of the body. Circulation is conspicuous at the optic region. Some pigments are interconnected along the intermyoformal septa.

**15 hours after hatching**

Length 4.2 mm and height 1.0 mm. Auditory capsule moves closer to the eye. Pigments over the iris are now denser. Mesenteron is seen as a blind tube and nephridial duct are conspicuous. Location of pectoral fin is marked by a thickened conical patch.

**24 hours after hatching**

Length 4.3 mm. and height 1.0 mm. Myotome count is 32. Buccal invagination appeared. Pectoral bud is now well pronounced. The air sac is differentiated as small tube below the pectoral fin bud. Eye fully pigmented.

**36 hours after hatching**

Length 4.4 mm. The pectoral fin is a round membranous flap and is being actively used for free movement. Mouth is formed as a terminal opening. Vent formed. Rudimentary gill opening and narial pits differentiated. A thick band of melanophores run from the post orbital region to base of the pectoral.

**2 days after hatching**

Length 4.6 mm. The pectoral fin is paddle shaped with undulating dorsal margin. Larvae move horizontally in schools. Lower jaw well developed. Trunk region is a little constricted at the nape. Only a vestige of the yolk is seen.

**3 days after hatching**

Length 5.0 mm. Pectorals which are moving vigorously, have been vascularised with a distinct semicircular vessel running across them. Opercula are membranous. Yolk is fully absorbed.

**6 days after hatching**

Length 5.2 mm. Yellow pigments are seen on the dorsal side giving a band like appearance. A similar yellow band is seen on the lateral aspect.

**8 days after hatching**

Length 5.3 mm. There is an yellow band on the dorsal line with a diamond shaped broadening at the nape. Laterally there is another band of the same colour between two dark lines. A broad lemon yellow path occur at the tail ventrally. Rudiments of two fin rays are seen in the caudal.

**11 days after hatching**

Length 6.1 mm. Colour bands are more distinct. Caudal fin rays five in number and hypurals are indicated as basal thickenings.

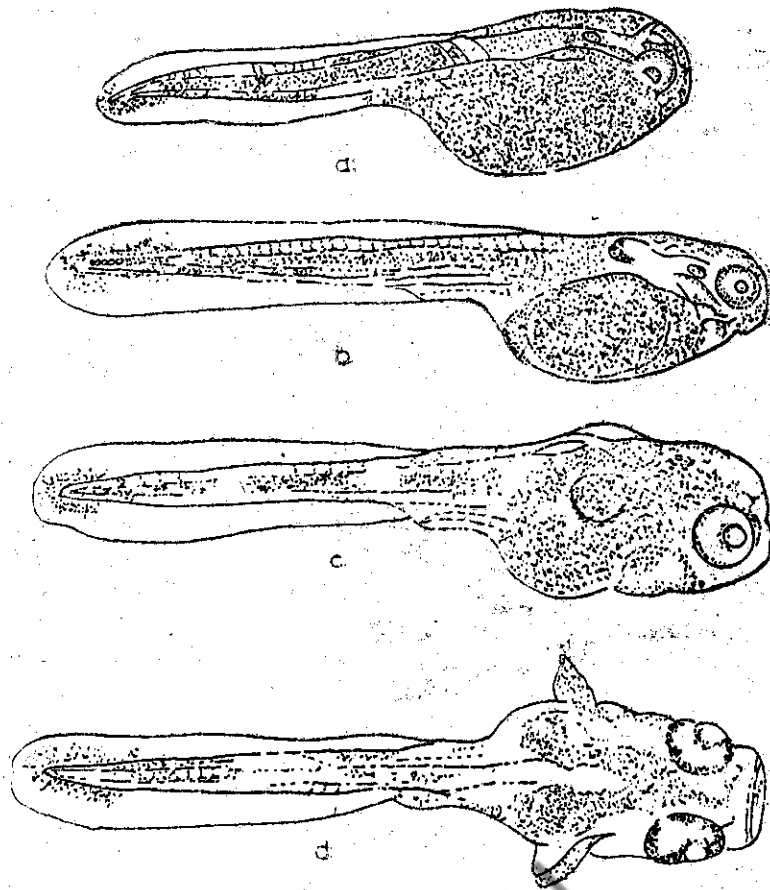

Fig. 7.5 Larva of *C. punctata*

a) 8 hours old

b) 24 hours old

c) 36 hours old

d) two days old

#### 18 days after hatching

Length 6.3 mm. Dorsal contour of the head is convex. Basal thickenings appear in the dorsal and ventral fin folds. Eight caudal rays can be distinguished, the middle ones showing articulation. The caudal fin is dark along the margin with bright yellow blotch in the middle. Silver and greenish pigments appear on the orbital rim and also on the post-orbital region.

#### 20 days after hatching

Length 7.2 mm. The fry assumes nearly the adult characteristics except the colour pattern. Rays start forming in all the fins from the 18th day onwards. There are 14 rays in the caudal, 19 in the anal, 25 in the dorsal and 17 in the pectoral at this stage. The fry has characteristic iridescent lemon yellow and dull longitudinal blotch bands. Aerial respiration is noticed. The fry move actively in schools.

The ventral fins are differentiated on the 23rd day when the fry measure 14 mm. Scales appear on the body by the 26th day when they are 18 mm long.

---

## 7.6 LIFE HISTORY, EGGS AND LARVAL STAGES OF CULTIVABEL PRAWNS

---

Generally the penaeid eggs hatch and metamorphose through four distinct stages:

1. Nauplius	4 to 5 stages
2. Zoea	3 stages
3. Mysis	3 stages
4. Post larva	6 to 7 stages

A brief account on *Penaeus indicus*, *Metapenaeus monoceros* and *Metapenaeus brevicornis* is given below:

#### 7.6.1. *Penaeus Indicus*

The species prefers higher salinity. The post larvae range in size from 5 to 10 mm in length. Post larvae are transparent white in colour excepting for pink colouration at the tip of the rostrum and the tip of the telson. Antennular peduncle tipped by light reddish colouration. Light yellowish colour on eye stalk. A few branched brownish chromatophores tinged with yellow present on the mid carapace on and on few of the mid abdominal segments and telson. A single dorsal tooth is present on the rostrum. The rostrum extends slightly beyond the eye in the first post larvae. A well developed super orbital hepatic spine is present. A median dorsal and lateral spine is present on the 5th and 6th abdominal segments. Anal spine is also present. Post larvae swim fast, moving along edges and surface. In swimming position, a prominent middorsal abdominal bend is very characteristic. In juveniles body remains transparent while upto length of 25 mm. Red spot at the tip of the rostrum continues to be present. On the uropod end telson a few dark reddish brown spots occur. The length of the rostrum is 6-8 mm. The elongated slender rostrum is the principal identifying character.

#### 7.6.2 *Metapenaeus Monoceros*

Identifying characteristics for different larval stages are :

Nauplius I	:	One pair of setae
Nauplius II	:	One pair of setae but plumose in appearance
Nauplius III	:	Three pairs of setae
Nauplius IV	:	6 pairs of setae with rudiments of maxillipedes
Nauplius V	:	7 pairs of setae with rudiments of maxillipedes and maxilla
Protozoen I	:	Appearance of abdomen and carapace.
Protozoen II	:	Appearance of stalked eye and rudiments of pereopods
Protozoen III	:	Appearance of uropod, abdominal spine and line
Mysis I	:	Presence of pleopod buds.
Mysis II	:	Pleopod buds with one segment.
Mysis III	:	Pleopod buds with two segments.

The late mysis measures 3-3.5 mm. in length. The size range of post larvae is 3.75-4.00 mm. Rostrum is very small falling short of the middle of the eye-stalk. The tip of the rostrum is acutely pointed. Two principal teeth are borne at the base of rostrum and one smaller tooth in front of the first principal one. A dorsal spine on 6th abdominal segment only. Post larvae have characteristic brown colour. Reddish pigmentation on the ventral side of abdomen and on entire telson. In later post larvae on the sides of the carapace bluish brown spots concentrate to form a band. A 'M' shaped bluish black patch is also seen on the dorsal side of abdomen at this stage.

#### 7.6.3 *Metapenaeus Brevicornis*

The size range of the post larvae is 3.0 - 3.5 mm. Rostrum is shortest. It just touches the border of carapace. Brownish in colour. In juveniles rostrum shows only slight increase in length exceeding the tips of the eyes while the basal elevation is more pronounced. Dorsal teeth are seven in number. Rostral length is 2.2 mm. Deep yellow coloration on carapace. Black red bands along the latero-ventral aspect of abdomen. Red spots on the uropods and telson.

### Check Your Progress

1. Write about 4th day after hatching post larva of rohu, *Labeo rohita*.
2. Characteristic of one day old larva of *Channa Punctata*.

---

### 7.7 SUMMARY

---

Life history of Rohu, *Cyprinus*, *Hypophthalmichthys*, *Ctenopharyngodon*, *Chang*, are described in detail.

Similarly the life history of some important cultivable prawns are also explained.

---

### 7.8 CHECK YOUR PROGRESS - MODEL ANSWERS

---

1. 7.6 mm in length yolk sac completely absorbed on the 4th day after hatching. Lip margins gently fimbriated. Distinct black Chromatophores seen behind the eyes on the head region. Opercular outline distinct. Notochord bent at the lip. Crescent shaped semicircular area below notochord in the caudal region formed of black chromatophores in rows ; the area of the semicircle well defined. Dorsal and ventral fin folds persistent. Commencement of caudal rays.
2. Length 4.6 mm. The pectoral fin is paddle shaped with undulating dorsal margin. Larvae move horizontally in schools. Lower jaw well developed. Trunk region is a little constricted at the nape. Only a vestige of the yolk is seen.

---

### 7.9 MODEL EXAMINATION QUESTIONS

---

#### I. Answer the following in about 30 lines :

1. Give a comparative account of the post larvae from 4th day to 15th day after hatching of (a) Catla (b) Rohu
2. Write an account of larval morphology of murrel, *Channa punctata*.
3. Write an account of larval morphology of introduced cultivable fishes.
4. Write an account of post larval morphology of cultivable prawns.

#### II. Answer the following in about 10 lines :

1. Embryonic history (before hatching) of *Channa punctata*
2. Comparative account of hatching of (a) Catla (b) Rohu
3. Larval characteristics of *Metapenaeus monoceros*

---

# UNIT - 8 SEED PRODUCTION - COLLECTION OF SEED FROM NATURAL RESOURCES AND BUNDH BREEDING

---

## Contents

- 8.1 Objectives
- 8.2 Introduction
- 8.3 Riverine Carp Spawn Collection
- 8.4 Riverine Fish Seed Resources
- 8.5 Riverine Spawn Collection Technique
- 8.6 Spawn Collection Gears
- 8.7 Spawn Collection Method
- 8.8 Hydrobiological characters in relation to spawn availability
- 8.9 Bundh breeding
- 8.10 Spawning
- 8.11 Collection of Egg
- 8.12 Improving village tanks
- 8.13 Summary
- 8.14 Check Your Progress - Model Answers
- 8.15 Model Examination Questions

---

## 8.1 OBJECTIVES

---

This unit deals with the traditional methods of collection of fish seed from the natural resources like river, bundhs etc. Natural habitat of the Indian major carps is the river and their original spawning grounds are the flooded rivers. This unit also deals with the recent seed prospecting investigations and to evolve the methods of collection of seed through scientific means.

---

## 8.2 INTRODUCTION.

---

The carp fishes normally breed in rivers during monsoon months under the natural conditions. Along with the fish seed of economic importance, uneconomic species which are mixed also are collected. Traditional methods of collection of carp spawn and fry from the natural resources like rivers, bundhs are still in practice. Inadequate scientific knowledge about the method of seed collection, spawn collection nets and seed transport resulted in a huge loss of valuable seed. Based on the scientific knowledge seed prospecting investigations were initiated in various river system in India. These investigations help in identifying the seed collection centre, use of spawn collection net etc. Bundhs are natural or artificially constructed tanks where riverine conditions are simulated, to breed the fish.

---

### 8.3 RIVERINE CARP SPAWN COLLECTION

---

Availability of fish seed in large quantities is a primary requisite to develop fish culture in India. Indian major carps *Catla (Catla catla)*, rohu (*Labeo rohita*) and mrigal (*Cirrhina mrigala*) are preferred for cultivation in freshwater ponds and tanks throughout the country. Natural habitat of these Indian major carps is rivers, and their original spawning grounds are the flooded rivers. Since a long time traditional methods of collection of carp spawn and fry from those natural resources were built up, particularly in Bengal, which soon spread to other states of eastern India. Fish seed trade even today depends on this resource.

Despite intensive collection of riverine carp spawn, inadequate scientific knowledge with regard to the method of collection, spawn collection nets, and seed transport result in a huge loss of valuable seed.

With a view to providing scientific basis, seed prospecting investigations were initiated in various river systems in India. Attempts were made to standardise the spawn collection nets, to evolve methods of collection and to ascertain factors responsible for fluctuations in the availability of fish seed in relation to time and place.

It has been estimated that fish seed collected from riverine resources contributed 91.6% to India's total fish seed production of about 3660 millions. It has also been estimated that about 6000 million fish seed are required to fulfill the stocking needs of cultivable freshwater areas in the country. In order to meet this huge deficiency of fish seed and to achieve self sufficiency, there is an immediate need to exploit the riverine resources and to locate additional fish seed collection centres.

---

### 8.4 RIVERINE FISH SEED RESOURCES

---

India comprises five major river systems namely the Ganga, Brahmaputra, Indus river system in the north, Peninsular east coast and west coast river systems in the south. Ganga, Brahmaputra and Indus are Himalayan river system which are fed by melting of snow, biologically very productive and they have richest fish fauna. The Indian major carps originally belong to the Ganga riverine systems. The east coast system of Peninsular India with Mahanandi, Godavari, Krishna and Cauvery and the west coast system consisting Narmada and Tapi rivers are rain fed. Gangetic major carps were transplanted into the rivers of the east coast system where they have established.

The Ganga river system fish seed in the form of eggs, spawn, fry and fingerlings are collected in huge quantities. This river system alone contribute about 89% of the total fish seed produced in the country. The first appearance of spawn in India occurs in river Kosi during May and June due to early floods caused by melting snow. Spawn is collected in large scale from the main Ganga river and its tributaries like Gomati, Padma and Bhagirathi. It was observed that productive centres in Ganga are not giving consistently good results year after year and it was noticed that indiscriminate exploitation of spawners and juvenile fishes are causing decline in spawn abundance. Fry and fingerlings are collected from Yamuna, Ganga, Sona rivers by cast and drag nets.

Large scale collection of carp eggs and spawn is made from the tributaries of Brahmaputra river. Good spawn collection centres were located on the river Sutlej of Indus river system. Spawn collected from Narmada in Madhya Pradesh contains 20 to 25% of Indian major carps. Mahanadi is a major source of fish seed which has been considerably exploited over the year.

Godavari and Krishna rivers with their tributaries mainly draining Andhra Pradesh are sufficiently rich in carp fisheries. Spawn collected from river Godavari at Rajahmundry consists of about 20% of major carps. Fry and fingerlings of major carps are collected during the post monsoon

months from the canals and paddy fields in Godavari and Krishna delta areas. Kolleru lake is also a good source of major carp fry and fingerlings. Carp fry and fingerlings collected from these resources are utilised to stock in ponds.

## 8.5 RIVERINE SPAWN COLLECTION TECHNIQUE

### Site selection

A premonsoon survey should be conducted in a given stretch of river. The survey is conducted to ascertain the topography of the terrain and bank features in the vicinity of a site. This will facilitate to determine the operational area to be available and for operation of nets. Survey should reveal the likely current pattern of the river at different stages of flooding, evolution of fish fauna and abundance of major carps during the monsoon season; Location of tributaries, rivulets and nallah's which form connecting links between river and breeding ground are to be noted.

River meandering in plains results in a serpentine course. The bends and curves of various shapes in the river course often have a fast eroding bank on one side called 'erosion zone' and a flat gently sloping bank exactly opposite called 'erosion zone' and a flat gently sloping bank exactly opposite called 'shallow zone'. Both these zones are unsuitable for spawn collection. Better spawn collection sites are generally located on the sides of the sloping bank where the current just diverges casting off spawn to the sides as if by centrifugal force. At these sites the spawn collection nets are fixed and operated.

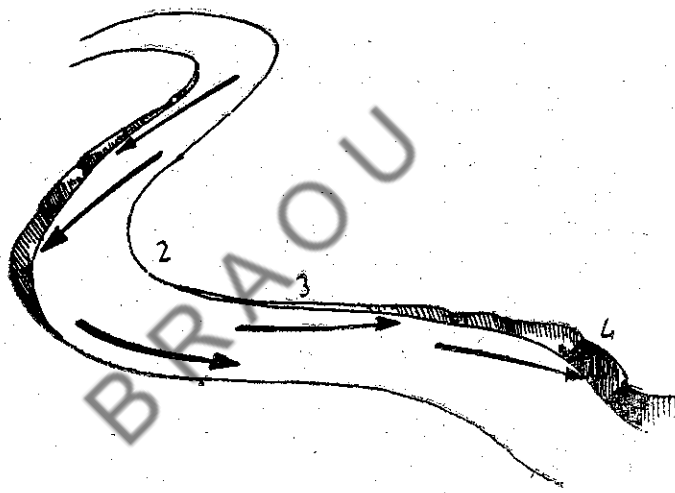

Fig 5.1 River meandering showing spawn collection site.

1. Erosion Zone    2. Shadow Zone    3. Suitable collecting ground    4. Erosion Zone

## 8.6 SPAWN COLLECTION GEARS

The net used for collection of spawn is known as shooting net. The net is a funnel shaped finely woven netting. This is operated in shallow margins of flooded river. Mouth of the net will face the current. At the narrow cod end of the net there is a stitched in ring of split bamboo or cane. At the time of operation a rectangular open piece of cloth 'gamcha' is attached to the cod end of the net. Gamcha is a receptacle into which the spawn moving along with the marginal current are collected. This receptacle is periodically scooped, sieved through a nonmetallic strainer to

remove larger organisms and debris. The spawn thus collected are stored in hapas or specially prepared mud pits.

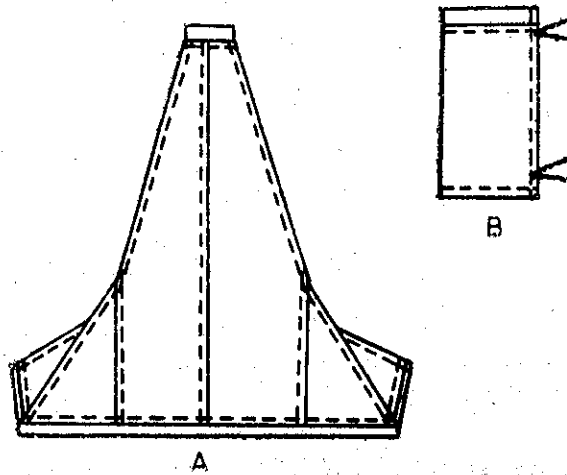

Fig. 5.2 A. Spawn collecting net B. Receptacle

Shooting nets used at various places are appreciable different from one another in form and dimensions. The 1/1" meshed midnapore type is considered as a standard net for the time being for country wide operations until a suitable and efficient net is designed.

Based on the various experiments conducted it has been proved that 14 m. nets of monofil 1/18" meshed nylon and 1/12 meshed cotton are the best with 200% efficiency in turbidities less than 600 ppm and velocity around 30 cm/sec. Nylon net appear to be quite suitable for continuous operation. The newly designed shooting net is similar to trawl net and has the following measurements. Length 300cm, with 300cm, ring diameter 30 cms, height at mouth 60 cms, height at ring end 29 cms.

This net along with the double walled receptacle for automatic sieving of spawn enhances spawn realisation.

---

## 8.7 SPAWN COLLECTION METHOD

---

After the premonsoon survey and the site of selection it is necessary to establish the exact spot from where maximum available spawn can be collected. To know the exact spot of availability a trial net is spread at 4 or 5 different spots separately to determine the site. The trial netting can be done with the help of boats.

After determining the site of availability of spawn the nets should be commissioned into operation. The arrangement of shooting net at the selected site should be in such a way that the axis of the net shall be in line with the current direction. The bamboo poles are planted firmly in the selected spot and the net is stretched over it. The anterior end of the gamcha is tied round the cod end ring where the spawn gets collected. The tail piece of net are scooped one after the other in quick succession every 15 minutes to 2 hours depending upon the intensity of collection. The collected spawn are scooped into containers half filled with river water. The collection is then passed through a round meshed mosquito netting to an improvised trough of muslin cloth. The lower third of the trough is kept immersed in water.

The spawn thus collected is measured depending upon their bulk. The collection is measured in 200 ml, 100 ml, 50 ml, 30 ml, 20 ml 5 ml, measuring cups.

The yield of spawn collection centre can be estimated from the catch per net hour by a unit net during a season. This is also called Index of spawn quantity. The total spawn yield of a given centre can be estimated from the net holding capacity of that area and the catch per net hour.

The importance of a spawn collection centre increases if the quantity of spawn is associated with the quantity of spawn.

Spawn catch can be categorised into major carp spawn, minor carp spawn and others.

---

## 8.8 HYDROBIOLOGICAL CHARACTERS IN RELATION TO SPAWN AVAILABILITY

---

Availability of spawn is correlated with the flood which plays a significant role. Normally each river experiences 3 or more floods during the monsoon season. Carp fishes breed in rivers which are associated with the floods. During the flood there would be sudden rise in water level which reaches the peak and slowly recedes. Age of the spawn and current velocity of the river at the spot shall help in identifying the breeding ground.

undesirable and uneconomic fish seed occur during the first flood in the river. Major carp spawn appears in subsequent flood. The spawn can be collected at any time of the day but night catch yields more spawn. The increase of water level to its peak or lowering of water level in the flood facilitates the spawn catch. The fish seed are washed off due to sudden rise in the water level which runs through the breeding ground where the spawn is produced

Current velocity stimulates the spawn to swim against the current. With the increase in current velocity the spawn migrates across the current or takes shelter. The spawn gets washed off when the current velocity of water increases beyond 0.36 - 0.42 Km. per hour. A shooting net arranged in the river gets a heavy catch at low current of 1 - 3 km./hour. Other hydrobiological factors like turbidity, pH, temperature, air plankton and dissolved oxygen has no relevance to spawn collection.

---

## 8.9 BUNDH BREEDING

---

The required fish seed can be collected from natural resource like the bundhs also. The bundhs are special type of tanks where riverine conditions are simulated and are naturally formed or artificially constructed. These tanks are filled in with water through out the year and are perennial in nature. Some tanks retain water only during the monsoon and are seasonal in nature. These bundhs receive rain water along with the washing from their catchments which are located at a higher level. Bundhs provide large shallow marginal areas which serve as spawning grounds for the fish.

Bundhs are of two types : (1) Perennial bundhs known as wet bundh (2) Seasonal bundhs known as dry bundh:

1. Extensive upland area from where the rain water carrying silt enters the main pond.
2. These have extensive shallow marginal areas which serve as ideal spawning grounds.
3. Gritty nature of soil suitable for breeding of fishes.
4. Increase in oxygen content of water which is due to vast and shallow area of the pond. The removal of old water of the pond in wet bundhs on account of in flow of fresh rain water and.
5. The temperature at spawning ground ranges from 22<sup>o</sup>C to 33<sup>o</sup> C in various environments.

---

## 8.10 SPAWNING

---

Spawning in both wet and dry bundhs usually occur after heavy showers when large quantity of rain water rushes into the bundh.

In wet bundh, during summer the deeper portion of the pond retains the water containing major carp breeders. After heavy showers, freshwater from catchment area rushes into the bundh in the form of streamlets. The major portion of the bundh gets submerged with water, excess flowing out through outlet which is protected by bamboo fencing made up of straw and mud. The spawning occurs in the shallow region of the bundh and the conditions required for natural breeding of carps in wet bundhs are not very exactly known.

In dry bundhs a set of major carp breeders in the ratio of 2:1 (2 males and one female) are introduced. Smaller fishes get stimulated early to breed followed by the bigger fishes. These fishes move about in search of spawning ground to the shallow area of the bundh.

Slight alteration in the structure of bundh was also done to improve breeding in the bundhs. Instead of rain water collecting in the bundh the water is stored in a reservoir located at a higher level. A series of small bundhs with inlets and outlets are constructed below the reservoir. The bundhs can thus be filled with rain water during monsoon and breeding operation can also be undertaken using the reservoir water. The reservoir is made use of in dry bundh system effectively.

Dry bundhs are considered to be one of the reliable means for mass breeding of grass carp and silver carp. Spawning may occur at night and during the bright sun in the forenoon. Mrigal and rohu occupies marginal area and breed in the morning. Catla occupy deeper water due to its big size and breed from noon till evening.

Fertilisation in major carps is external. The fertilised eggs are left behind by the parents. The eggs get drifted to the edges of the bundh or get washed down. In bundhs a large number of eggs settle down in shallow water giving a pale whitish appearance. The adult fish move to deeper areas.

---

## 8.11 COLLECTION OF EGG

---

The eggs are collected from the bundh with the help of nets made up of netting cloth. The eggs thus collected are released into improvised pits or in double walled hatching hapas or in cement cisterns. Each hatching pit of the size 448 cm X 244 cm X 46 cm is excavated on the bank with arrangement for supply of water. Each pit can accommodate 900,000 to 2,200,000 eggs of which 2.5% to 25% hatch successfully.

A double walled hapa consisting of outer hapa made of ordinary cloth measuring 182 cm x 91 cm x 91 cm and inner hapa made up of round meshed mosquito netting measuring 152 cm x 76 cm x 46 cm is fixed in the bundh. These hapas are laid perfectly in horizontal positions one within the other with a water depth of 23 to 30 cms. The hatchlings passing out into the outer hapa are retained for three days for conditioning before stocking. The survival rate ranges from 32 to 53%.

A cement hatchery of 2.40 m x 1.20 m x 0.30 m in size near the bundhs is much economical with survival of hatchlings to 197%.

The spawn collected from the rivers or bundhs comprises mixed species. These spawn is sieved through round meshed mosquito netting cloth on to a muslin cloth suspended in water. An attempt was made to segregate the spawn species wise based on the dissolved oxygen consumption. This showed that with the depletion of oxygen in the water the spawn started crowding at the surface. Mrigal spawn first moved to the surface followed by catla and rohu spawn.

The hydrobiological characters like pH, dissolved oxygen, alkalinity, chlorides, minerals have no significant part in spawning of carps in bundh breeding. Heavy monsoon flood, the sudden inflow of rain water washing the breeding ground, bring about successful spawning.

---

### 8.12 IMPROVING VILLAGE TANKS

---

Taking advantage of an adjacent drain, an ordinary tank can be converted into a fish breeding tank. The tank should be provided with similar conditions present in perennial bundhs. The tank should be filled with water. The water at the shallow spawning ground should be kept about 1 foot in depth by regulating the passage at the outlet end. Spawning of fishes occur in these tanks. In addition, gonadial development and sexual maturity in fish can be observed in such ponds. Depending on the location of fish culture the best economic method of seed procurement and stocking one of the various methods described above should be selected.

#### Check Your Progress

1. The net used for collection of spawn is known as \_\_\_\_\_ net.
2. Major Carps spawn is available in large quantities in \_\_\_\_\_ rivers.

---

### 8.13 SUMMARY

---

The collection of seed from natural resources and various techniques involved in the collections are explained here. Even the resources where the fish seed are generally available are also described.

The gears used in spawn collections of the methods applied are explained. Bundh breeding is also given.

---

### 8.14 CHECK YOUR PROGRESS : MODEL ANSWERS

---

1. Shooting net
2. Flooded.

---

### 8.15 MODEL EXAMINATION QUESTIONS

---

I. Answer the following in about 30 lines.

1. What are the different fish seed resources of Indian rivers?
2. Explain the riverine spawn collection technique adopted for collection of spawn.
3. What is a bundh ? Describe how the bundhs help in the breeding of carps ?

II. Answer the following in about 10 lines :

1. Dry bundh breeding.
2. Wet bundh breeding.
3. Spawn collection net.
4. River meandering.

---

# UNIT-9 SEED PRODUCTION - INDUCED BREEDING, HATCHERY SYSTEMS AND SEED TRANSPORT

---

## Contents:

- 9.1 Objectives
- 9.2 Introduction
- 9.3 Pituitary gland
- 9.4 Pituitary gland collection and preservation
- 9.5 Brood fish stock maintenance
- 9.6 Induced breeding Technique
  - 9.6.1. Selection of breeders
  - 9.6.2. Dosage of pituitary injection
  - 9.6.3. Preparation of pituitary gland extract and injection
- 9.7 Spawning
- 9.8 Estimation of Eggs
- 9.9 Induced breeding of Chinese silver Carp and Grass Carp
- 9.10 Breeding of Common Carp
- 9.11 Hatchery Systems
- 9.12 Modern Indian Hatchery System
- 9.13 Fish Seed transport
- 9.14 Summary
- 9.15 Check Your Progress - Model Answers
- 9.16 Model Examination Questions

---

## 9.1 OBJECTIVES

---

This unit describes about the recent scientific methods to breed the cultivated fishes in confined waters, to hatch their eggs in large scale and transport the fish seed to long distances. These technologies provide dependable source of quality fish seed to expand and intensify the fish farming in India. Expansion and intensification of fish farming depends on the availability of quality fish seed. The Indian Major carps and the Chinese carps introduced into India which are extensively cultivated in fresh water ponds, do not normally breed in confined waters though they attain gonadal maturity. These carp fishes normally breed in rivers during monsoon months and fish farmers had to depend on natural seed collected from rivers which are mixed with uneconomic species. Researches were initiated and developed a new technique known as induced breeding or Hypophysation to produce pure fish seed. The pituitary gland of fishes are collected, hormones extracted and injected to the selected Indian Major carp brood fish during favourable monsoon period and spawning is achieved. The Chinese carps after pituitary gland extract injection, are stripped and eggs are fertilised with milt by adopting either dry or wet

stripping method. Carp eggs thus produced are transferred to hatcheries for obtaining better survival. Fish seed are transferred to long distances under oxygen packing.

---

## 9.2 INTRODUCTION

---

The Indian Major carps, *Catla* (*Catla catla*), rohu (*Labeo rohita*), mrigal (*Cirrhina mrigala*) and the chinese carps introduced into India. Silver carp (*Hypophthalmichthys molitrix*), grass carp (*Ctenopharyngodon idella*) which are extensively cultivated in fresh water ponds do not normally breed in confined waters though they attain gonadial maturity.

India Major carps and Chinese carps, however, breed in the rivers during monsoon season. Indian major carps breed in the specialised environments, wet and dry bunds, where in fluviatile conditions are simulated during monsoon months.

The fish culturists therefore had to depend for the fish seed on collection from the river systems. Carp seed thus collected from rivers consist not only of preferred species but also uneconomic species.

The limitations and uncertainties in procuring the fish seed prompted the need for developing suitable methods to obtain the pure seed of cultivated Indian and Chinese carps.

Researches were initiated on this aspect and a major breakthrough in Indian seed production took place in the year 1957 when success was achieved in breeding the Indian major carps, rohu and mrigal, through hypophysation by H L Choudhuri and K. H. Alikunhi of Central Inland Fisheries Research Institute.

Since then this technique was improved by several Indian scientists. Successful induced spawning of chinese carps was achieved in 1962. This technique became a popular and dependable source of supply of quality seed of cultivated carps throughout India. The induced breeding technique also furnishes a practical tool for selective breeding and hybridisation.

The technique of spawning the fishes under controlled conditions by administering pituitary hormone injection is known as 'Induced breeding' or 'hypophysation'.

---

## 9.3 PITUITARY GLAND

---

Pituitary gland is an important endocrine gland in the fish. It is a small, round or pear shaped gland located on the ventral side of the brain immediately behind the optic chiasma in a concavity on the floor of brain-box known as sella tunica.

The pituitary gland of fish secretes a large number of hormones as in higher vertebrates. Important hormones are the gonad stimulating hormones-gonadotropin, growth stimulating hormone-somatotropin and the thyrotropic hormone-thyroxin. It is believed that teleostean pituitary contains both FSH and LH like gonadotropins. The release of gonadotropins is influenced by environmental factors like monsoon rains, temperature, photoperiod etc. Gonadotropins regulate the seasonal reproductive cycle of fishes.

---

## 9.4 PITUITARY GLAND - COLLECTION AND PRESERVATION

---

It is always preferable to collect the pituitary gland from freshly killed matured donor fish or from fishes preserved in ice. The glands may be collected from both the sexes of the same species as the recipient fish or closely related fishes.

In fish markets where severed heads of fish are sold, the pituitary glands can be collected from behind the head through foramen magnum after cleaning the brain tissue.

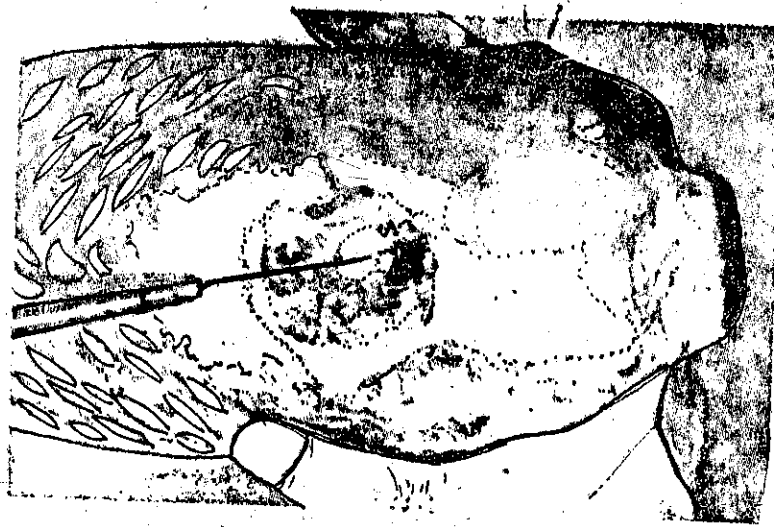

Fig 9.1. Collection of pituitary gland

Pituitary gland can also be collected by cutting and opening a portion of the scalp or brain case by a hand saw or sharp butchers knife. The exposed brain is lifted and the gland is removed with fine forceps without any damage to the gland.

The pituitary gland thus collected should be preserved immediately in absolute alcohol. The alcohol is frequently changed to keep the pituitary gland in good condition for longer period. The phials or glass bottles (amber coloured) may be kept in cool, shady place at room temperature or in the refrigerator. The hormones are insoluble in absolute alcohol. The absolute alcohol defattens and dehydrates the gland. The accurate weight of individual glands is noted, as this is essential for accurate determination of the dose of gland to be given according to the weight of the breeders.

The pituitary gland extract can also be preserved effectively in glycerine. Through this significant method commercial production of pituitary extract can be made and preserved for a long time. Pituitary extract is prepared in distilled water and preserved in pure glycerine. The concentration of the extract is 40 mg of pituitary gland in 1 ml. of distilled water and glycerine. The ratio between distilled water and glycerine is 1:2 at the time of preparation. The pituitary extract in distilled water and glycerine is kept in air tight bottles to allow the sediments to settle down. Then the preserved suspension is filtered through a filter paper and is taken into one ml. ampoules for storing. The glass ampeoules are then sealed and kept either in room temperature or in refrigerator. Thus each 1 ml. ampoule contains the extract of 40 mg pituitary glands.

---

## 9.5 BROOD FISH STOCK MAINTENANCE

---

Primary requirement for successful induced breeding programme is collection of adequate stock of good brood fishes. The potential brood fish collected from ponds and tanks are stocked and maintained in separate brood fish ponds at the rate of 2000 kg per hectare. This brood stock should be collected a few months (January onwards) prior to the commencement of the breeding season (June-July). To attain healthy growth and proper gonadial maturity the brood fish are fed with supplementary food comprising a mixture of powdered rice bran and oil cakes (groundnut, mustard). They are fed daily at the rate of 1% to 2% of body weight of the brood fishes.

Periodic examination of the fish should be carried on to determine the gonadal condition and health condition. Rough handling of matured fishes should be avoided, whenever they are metted, fishes should be given a prophylactic dip treatment in 1 ppm potassium permanganate. It is better to segregate males and females and maintain them in separate ponds.

---

## 9.6 INDUCED BREEDING TECHNIQUE

---

### 9.6.1. Selection of breeders

The sexes are separate in fishes. Gonadal maturity of the cultivated carps occurs during the monsoon season, and during this breeding season morphological characters like roughness of pectoral fin helps in identification of sexes.

A male brooder fish can be identified by the roughness of dorsal surface of the pectoral fin. The ripe male has flat abdomen and on slight pressure on the abdomen, a milky white secretion known as 'Milt' oozes out.

A female brooder fish can be identified by the smoothness of the pectoral fin. A fully ripe gravid female has a bulging abdomen with swollen reddish vent.

Healthy carp breeders of the age group of 2-4 years with weight ranging from 1 to 5 kg., are considered suitable for breeding purpose. A medium sized fish is preferred for easy handling and in view of having large number of eggs. The selected breeders are kept in hand net without causing any injury to it. The particulars regarding the weight of the brood fish are noted separately.

### 9.6.2. Dosage of pituitary injection

Proper determination of pituitary gland dosage to induce the fish to breed plays an important role. If the environmental conditions like rain, temperature etc., are favourable and the brooders are fully ripe, minimum dosage may be sufficient. If not slightly higher dosage may be required. It is always advisable to give a preliminary low dose to female breeder followed by a higher effective dose after 4-6 hours.

To the Indian major carps, preliminary dose of 2-3 mg. of pituitary gland per Kg body weight of fish is administered to the female breeder only. After 4-6 hours a second dose of 5-8 mg gland per Kg body weight is given to the female. A single dose of 2-3 mg. per Kg. body weight is administered to the male at the time of giving second injection of female.

The injection may be given at any time in the day or night. But it is preferable to inject the fishes in the evening or night when temperature is fairly low.

### 9.6.3. Preparation of pituitary gland extract and injection

The pituitary gland extract is prepared just before the time of injection. The quantity of pituitary glands required for injection is calculated on the basis of weight of brood fish. Pituitary glands taken out from the phials are kept initially on a filter paper for about a minute to allow alcohol to evaporate. Then the glands are macerated in a tissue homogeniser with a little quantity of distilled water. The homogenized gland extract is diluted by adding required quantity of distilled water. The dilution should not be too thick or thin. The dilution is generally made at the rate of 20-30 mg. of the gland in 1.0 ml. media. A maximum of 1.0 ml. and a minimum of 0.1 ml. suspension should be injected to a brood fish depending on the size of fish.

The gland suspension is then centrifuged by a hand or electric centrifuge. During the process tissue particles settle down at the bottom of centrifuge tube as sediments. The supernatant fluid containing the hormones is drawn into a hypodermic syringe for injection.

Intra muscular injection is found to be more effective and easier, Intra peritoneal injections given at the base of pelvic fin may damage the internal organs. The injection is administered at

the caudal peduncle region under the scale. First the needle inserted should be parallel to the body of the fish and then pierced into the muscle at an angle. The most convenient hypodermic syringe used for the purpose is a 2 cc one having graduations to 0.1 cc. division. The size of the needle for the spring depends upon the size of brood fish to be injected. The BDH needle No.22 is used for 1-3 kg. of carp brood fish. Needle No.19 is used for larger ones and needle No. 24 is used for smaller ones.

one set of brooders consisting of one female and two males, depending on the size and weight is usually introduced into each breeding hapa. Weight of the male breeders together should be equal or little more than that of the female.

The breeding hapa is a rectangular box like containers with ropes for tying to bamboo poles at four corners. All the sides of hapa are stitched and closed excepting a portion at the upper horizontal wall. Through this opening the brood fish are introduced or taken out as and when required. After introduction of the fish the opening of the hapa is closed tightly by lace to avoid the escape of the fish. The breeding hapa is made up of fine close meshed mosquito cloth preferably made up of nylon. This type of cloth facilitates proper circulation of water in the hapa. Four sizes of breeding hapas may be used for breeding different weight groups of Indian carps.

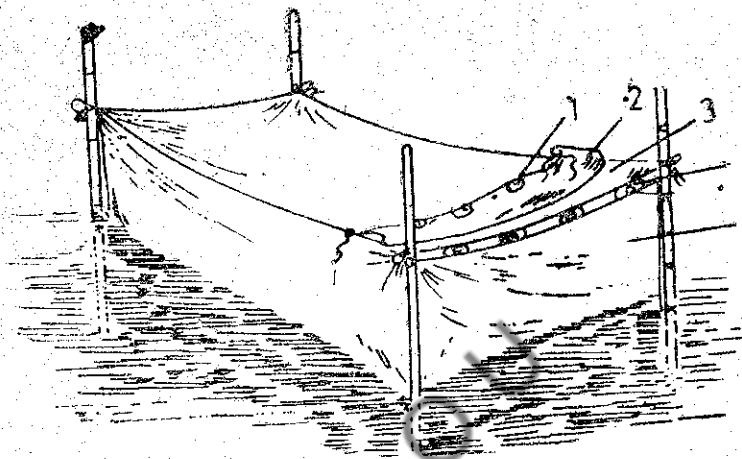

Fig 9.2 A breeding hapa showing a portion of the upper horizontal flap open (the open end), fixed in water with four bamboo poles 1. Button 2. Upper horizontal flap 3. Open end 4. Button hole 5. Vertical flap.

1. 3.5 x 1.5 x 1.0 m. for breeders weighing over 5.0 Kgs.
2. 3.0 x 1.5 x 1.0 m. - do - 3-5 kg.
3. 2.5 x 1.2 x 1.0 m. - do - 1-3 kg.
4. 1.8 x 0.9 x 0.9 m. - do - 1.0 kg.

The hapa is fixed in such a way that about 15 to 20 cm. of it remains above the water, care should be taken so that insects, crabs, minnows will not enter into the breeding hapa. A cement cistern as big as hapas can also be used with a water level of 30-35 cm. Tap or well water may be used but chlorinated water must be avoided.

## 9.7 SPAWNING

The carps breed within a wide range of water temperature at 24- 35<sup>o</sup>C but below 30<sup>o</sup>C is optimum. The spawning takes place 3-6 hours after second injection. The eggs are examined to

evaluate the percentage of fertilisation. The fertilised eggs are transparent and look like pearls due to swelling up of eggs. Unfertilised eggs become opaque and whitish. The carp eggs are nonfloating and nonadhesive in nature and round in shape. The size of the eggs of carp varies from 4 to 6.5 mm. in diameter.

---

## 9.8 ESTIMATION OF EGGS

---

The eggs are collected from the hapa by means of cup or tray or beaker and transferred to the buckets. the breeders are also removed from the hapa and their weights are noted. The difference in weights reveals approximately the number of eggs laid. The eggs are kept in a rectangular piece of close meshed mosquito net and allow the water to drain off. The eggs are measured in a beaker, mug or cup of known volume and transferred to hatcheries. Thus estimation of total quantity is made from total volume of the eggs measured. Percentage of fertilisation can be arrived at by counting the number of fertilized eggs from egg samples of 1 ml. measure.

---

## 9.9 INTRODUCED BREEDING OF CHINESE SILVER-CARP AND GRASS-CARP

---

The technique of hypophysation followed to induce the grass carp and silver carp is almost similar to that used for the Indian major carps. The Indian major carps breed naturally in the hapas after injection whereas the grass carp and silver carp have to be stripped and the ova artificially fertilised.

One set of breeders i.e., one female and two males are selected for breeding and administered with the pituitary extract injection. The female fish is given two injections and to the male fish, one injection at the time of the second injection to the female. Two split doses of pituitary gland at rate of 9-12 mg per Kg. body weight of the female and a single dose of 3-4 mg per kg body weight of male is administered respectively. After the second injection, the female brooder is examined periodically for every one hour. When the female is ready to release the eggs in response to gentle touch over the abdomen it is taken out from breeding hapa for stripping and fertilising the eggs.

The eggs are stripped and fertilised by two methods of stripping namely dry method and wet method. In the dry stripping process, the moisture over the body of the fish is wiped with dry cloth. The ova from the female is stripped into a dry basin and over the eggs, the milt is stripped from the male immediately. the basin is slowly shaken or the ova is gently stirred with a feather so that the milt comes in contact with all the ova. Later, freshwater is added and the fertilised eggs are washed repeatedly.

In wet stripping the water is taken into the basin and the ova from the female and the milt from the male are stripped simultaneously and put into the basin. After hardening of the fertilised eggs, they are taken out for hatching in hapas or glass hatchery.

---

## 9.10 BREEDING OF COMMON CARP

---

Common carp (*Cyprinus carpio*) generally breeds in confined water. Spawning takes place in shallow marginal, weed infested areas from January to March and from July to August. Common Carp is also observed to breed round the year. Controlled breeding of common carp is conducted to achieve better spawning and hatching. A set of selected brooders one female and two males are put together in breeding hapa. In order to ensure successful spawning sometimes the female fish is injected with pituitary gland extract at a low dose 2 to 3 mg per kg. body weight. Freshly washed aquatic weeds (*Hydrilla*, *Najas*, *Eichhornia* etc) are uniformly distributed inside the hapa. These

aquatic weeds act as egg collectors. The quantity of weed used is roughly double the weight of the female introduced. Each weed attached with 40,000 to 1,00,000 eggs are distributed into a single hatching hapa. After 4 or 5 days the weeds are taken out carefully.



Fig 9.3 Common Carp eggs attached to Eichhornia Sp.

## 9.11 HATCHERY SYSTEMS

Eggs are hatched generally in a hatching hapa. A hatching hapa consists of two rectangular hapas the outer and the inner similar to that of the breeding hapa. These two hapas are arranged or fitted one inside the other. The outer hapa is made up of fine meshed muslin cloth of the size of 2 x 1 x 1 m and the inner round meshed mosquito net hapa of size of 1.75 x 0.75 x 0.5 m with upper ends open. The hatching hapas are fixed in pond in such a way that 25 to 30 cm of the upper edge of th hapa remains above water.

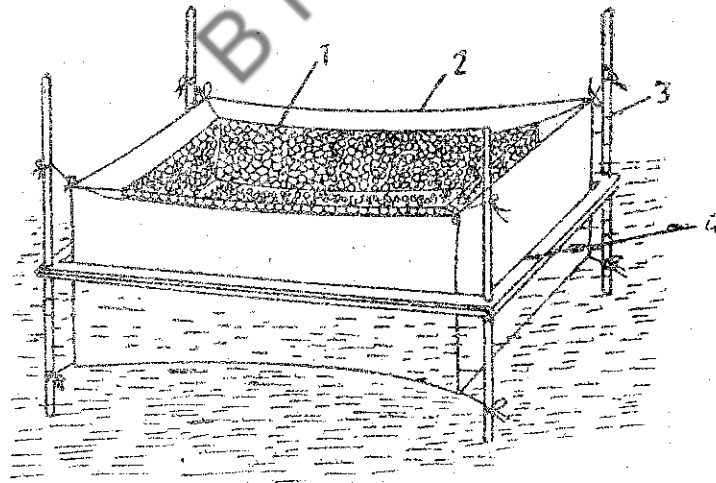

Fig.9.4 Floating hatching hapa.

1. Inner mosquito net hapa. 2. Outer hapa 3. Perpendicular arm 4. Rectangular frame.

About 75,000 to 1,00,000 eggs are uniformly spread on the stretched bottom of the inner hapa. Hatching of eggs varies according to water temperature. The eggs usually hatch out (incubation period) in 15-16 hours at a temperature ranging between 27 and 31°C. After hatching the larvae escape to the outer hapa through the meshes of the inner one. The egg shells and bad eggs are left behind in inner hapa. After hatching of all eggs the inner hapa is taken away along with egg shells. The hatchlings in the outer hapa are allowed to remain there undisturbed till the third day. On the third day the hatchlings are collected from the outer hapa when the yolk sac is mostly absorbed and the swan is ready to feed zooplankton. These hatchlings are collected, measured and counted in number and then stocked in nurseries for further raising. These hatchlings are measured in small perforated aluminium cups of known volume called spawn measuring cups. In this process percentage of hatchling and survival of hatchlings will be about 60% only.

## 9.12 MODERN INDIAN HATCHERY SYSTEM

Hatchling of carp eggs in the cloth hapa may sometimes result in heavy mortality of developing embryos and spawn due to natural hazards and fluctuating environmental conditions. In this method, obtaining large quantity of spawn poses problems. Efforts have been made to control these variables and evolve hatchery system which should be independent of the external environment and can ensure high efficiency in breeding and hatching. Different types of hatcheries such as glass jar hatcheries, earthen pot hatcheries, cemented hatcheries, galvanized iron jar hatcheries aluminium, polyethylene hatchery bins were developed and tested for breeding.

The glass jar hatchery complex is self-contained unit consisting of water supply system, breeding tanks, incubation and hatching jars and the spawnery. The water supply system consists of the overhead tank or reservoir which is pumped with water and is placed at 4 metre higher level. Breeding tanks are meant for spawn production and they receive water from aeration. Forty jars to accommodate twenty lakhs of eggs at the rate of 50,000 in each jar can be set up. The hatching glass jar with 6.35 litre capacity is cylindrical towards the bottom and accommodates

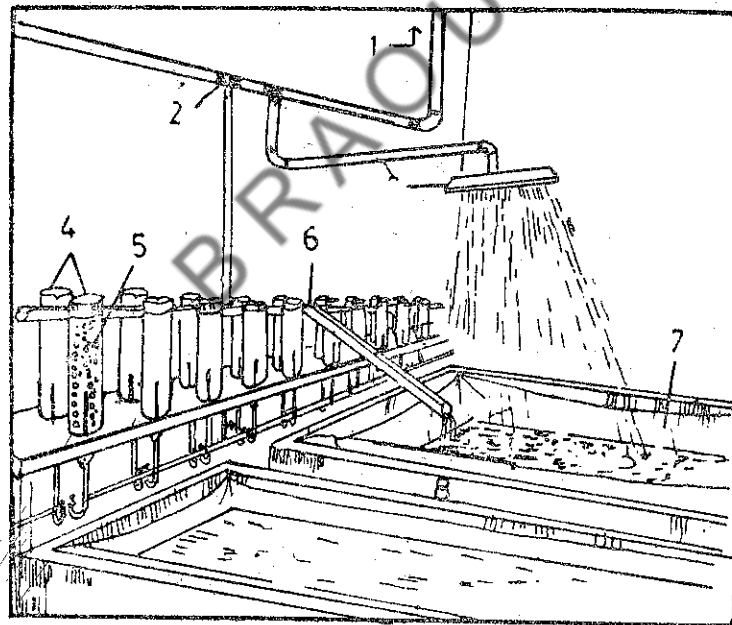

Fig. 9.5 The glass Jar complex hatchery

1. Over head tank
2. Water supply line
3. Shower
4. Glass Jar
5. Fertilized eggs
6. Open Conduit
7. Hapa (Spawnery)
8. Cement Cistern

50,000 eggs. The eggs are gently introduced into the jar. Flow of water in jars is regulated to ensure the proper circulation of eggs. Flow of water at the rate of 600 to 800 ml, per minute Indian major carps and 800 - 1000 ml. per minute for silver carps and grass carp is sufficient to keep the eggs in circulation. This arrangement for circulation of water provides more dissolved oxygen and increases the rate of hatching. The rate of flow of water may be increased after completion of hatching. This facilitates easy escape of hatching from jars through the outlet along with the flow of water leading to spawnery. The egg shells, dead, rotten eggs are left behind in the jars which are subsequently removed by disconnecting the jar from the tap.

The spawnery is a nylon hapa placed inside a cement cistern. To keep the water cool, to maintain temperature and aeration an overhead shower (to spray water over the developing hatchling in the spawnery) is arranged. The two spawneries can accommodate 10 lakhs of spawn in each. The spray of water is continued for about three days till the fry hatches out.

---

### 9.13 FISH SEED TRANSPORT

---

Traditional methods of carrying the seed in earthen pots taken as head load from the production centre to the market an ancient practice in the eastern states of India. This type of transport resulted in heavy mortality.

With a view to developing dependable methods of fish seed transport, investigations have been made. Studies have revealed that deficiency of oxygen and high carbon dioxide tension in the transport medium. The toxic effect of accumulated waste products like ammonia and other metabolites in the medium, over activity, exhaustion and injuries are the main cause of seed mortality during their transport.

There are two methods of packing and transporting the fish seed.

- (i) Open system - comprising open carriers, with or without artificial aeration, oxygenation, water circulation and
- (ii) Closed system - Sealed air tight carriers with oxygen. For long distance transport with both the systems of transport, spawn and fry are conditioned to make them live in a restricted area during transport. Various types of conditioning containers are used like temporary enclosures made of netting material, cloth hapa etc. The most common method of conditioning is to keep the seed in a cloth hapa fixed in ponds.

The period of conditioning depends on the size and health of the spawn, the fry, and the fingerlings. Generally major carp fry and fingerling need about 1 to 6 hours of conditioning for long distance transports. Fry conditioned for prior to transport in a limited volume of water (1.8 to 2.3 ml. of water per fry) at a minimum of 0.88 ppm. of oxygen was quite successful. During conditioning and transportation fry and fingerlings should not be handled with bare hands. The slime and scales covering the body if removed are vulnerable to fungal and bacterial infections.

Aluminium carriers called as 'hundreds' of variable size are being used. The smaller hundi is of 23 cms. diameter and 23 litres capacity can accommodate 50,000 fry and is meant for carrying as head load. The bigger hundi is of 23 cms. diameter and 32 litre capacity of can carry 75,000 fry and is meant for transport by rail. During transport, the hundi is shaken well periodically for aeration. Sometimes red soil is added to coagulate the suspended organic pollutants. The bottom sediments are periodically removed. If necessary water is partially changed. This type of open container can permit to transport of fry upto a duration of 30 hours.

Improved metal containers with wide mouth of 53 cms. diameter at the base, 20 cms. at the mouth and 38 cms. height are being used at present. The wide mouth of the container can be closed with perforated lid allowing air space above the surface of water. Though this is a cheap method, it involves constant vigilance and frequent renewal of water on long journeys. It is difficult to transport bigger fingerlings in these open containers.

In closed fish seed packing systems the course of oxygen supply is not the open air but oxygen supplied into space above the water.

Recently polythene bags were introduced to transport fry and fingerling. Polythene bags of 74 cms. x 46 cms. and 33 litres capacity are now widely used for transport of carp seed under oxygen.

The latest technique of transporting the fish seed is the use of the conventional kerosene tins which are remodeled with an open lid or similar tin carrier with galvanized sheet. Plastic bags of 45x65 cms. size made of 250 to 300 guage sealed at one end in the kerosene tin are used. This bag is kept into the tin container filled with 1/3 to half to half of the capacity of 6 - 9 litres if water and then the seedlings are kept and filled with oxygen after driving out the air from the bag. This bag is tied carefully to prevent leakage of oxygen.

Thus by adopting the modern technique of hypophysation the fish culture which wholly depend on the quality fish seed can be taken up on a large scale and the demand for fish seed is met while having the profit. The demand for fish seed can be solved only when the private sector comes in a big way into the field assisted by the banks with liberal loans.

#### Check Your Progress

1. \_\_\_\_\_ gland is an important structure especially used for induced breeding.
2. Hatching hapa.

---

#### 9.14 Summary

---

In this unit the details of pituitary glands and its use in Induced breeding techniques are explained in detail. Selection of breeders, usage of induced breeding technique in chinese silver carp, and grass carp are given. The methods to be adopted in seed transport are also given here.

---

#### 9.15 CHECK YOUR PROGRESS - MODEL ANSWERS

---

1. Pituitary gland
2. A hatching hapa consists of two rectangular hapas the outer and the inner similar to that of the breeding hapa. These two hapas are arranged or filled one inside the other. The outer hapa is made up of fine meshed muslin cloth of the size of 2x1x1 m and the inner round meshed mosquito net hapa of size of 1.75x0.75x0.5 m with upper ends open. The hatching hapas are fixed in pond in such a way that 25 to 30 cm. of the upper edge of the hapa remains above water.

---

#### 9.16 MODEL EXAMINATION QUESTIONS

---

##### I. Answer the following in about 30 lines

- i) What is induced breeding ? Explain the induced breeding technique followed to induce the Indian major carps.
- ii) Describe the hatchery systems followed for successful hatching of carp eggs.
- iii) How are fish seed packed and transported from place to place? Explain.

**II. Answer the following in about 10 lines.**

1. Pituitary gland collection and preservation.
2. Maintenance of brood fish stock.
3. Stripping methods in chinese carps.
4. Induced breeding technology in modern times.
5. Spawning and Estimation of egg.

BRAOU

---

# UNIT - 10 FARM POND - SITE SELECTION, DESIGN AND CONSTRUCTION OF POND

---

## Contents

- 10.1 Objectives
- 10.2 Introduction
- 10.3 Site Selection
- 10.4 Soil Type
- 10.5 Topography
- 10.6 Water Supply
- 10.7 Designing
- 10.8 Construction
- 10.9 Maintenance of the pond
- 10.10 Summary
- 10.11 Check Your Progress - Model Answers
- 10.12 Model Examination Questions

---

## 10.1 OBJECTIVES

---

This unit deals with the types of fish ponds. The vital considerations for the selection of a suitable site for the construction of ponds have been discussed. The points to be borne in mind while designing the farm and the various aspects of construction of ponds have been dealt. The maintenance of ponds has also been discussed in this unit.

---

## 10.2 INTRODUCTION

---

The production of table size fish and the fish seed mainly depend on the designing and construction of ponds. The basic principles involved in designed and construction of ponds meant for the culture of fishes and prawns are of very specialised nature and vary from region to region, depending upon several factors like topography, soil type, water supply etc. The basic requirements for the designing and construction of a fish farm are completely different from the agriculture and animal husbandry farms. Recent advances made in the fields of agricultural and irrigation engineering are being adopted in the designing and construction of fish ponds.

A fish culturist needs different types of ponds for rearing various sizes of fish. The number and sizes of ponds depend on the species of the fish to cultured. Atleast three different types of ponds viz., nursery, rearing and stock ponds are required for carp culture. These three kinds of ponds differ from each other in respect of size, area and depth of water.

The ponds which are small and shallow having an area of 0.02 ha to 0.08 ha (20 m x 10 m \_\_\_\_\_ 40 m x 20 m) with a depth of 1.2 m to 1.5 m are called as nursery ponds. These ponds are

used for raising fry from spawn (5.6 mm to 25-30 mm). The nursery ponds should preferably be seasonal in nature.

The rearing ponds are slightly larger in size than the nursery ponds. The size of rearing ponds vary from 0.08 ha to 0.10 ha (40 m x 20 m \_\_\_\_\_ 50 m x 20 m) with a depth of 1.5 m to 2.0 m. These ponds are used for rearing fingerlings from fry (25 - 30 mm to 100 mm and above). The rearing ponds may be seasonal or perennial.

The third type of ponds known as stock ponds are still larger than the rearing ponds. They differ in size from 0.2 ha to 2.0 ha with a depth of 2.0 m to 2.5 m. It is desirable that the stock pond is more than 0.5 ha in area. These ponds are utilised for stocking the fingerlings in order to obtain table size fish. They should be perennial.

The ponds should be rectangular in shape. The width of the ponds should not exceed 40 m. This will facilitate longer run for fish to achieve healthy growth and also smaller nets and lesser number of people are required to catch the fish. Larger ponds are difficult to manage particularly with regard to the controlling of aquatic weeds.

Existing ponds which conform to the above specifications could be used for carp culture. However when these are constructed especially for fish culture, ponds which can be filled in or drained out at will are the best but such ponds are difficult and expensive to construct in our conditions.

The factors to be taken into consideration for farm pond construction can be broadly divided into three viz., 1. Site selection, 2. Designing and 3. Construction.

---

### 10.3 SITE SELECTION

---

Economy of fish pond construction and the productivity of pond largely depend on the selection of a suitable site. Therefore great care should be taken to select the best possible site for pond construction. Site selection for the construction of ponds for carp culture involves three vital considerations viz., soil type, topography and water supply.

---

### 10.4 SOIL TYPE

---

The sub-soil of the pond should be such that it can hold water. Agricultural land should not be used for construction of fish ponds. Sites near river courses or dry river beds and tail ends of reservoirs should be avoided. Barren, slightly sandy, marshy or water logged areas should be chosen as suitable sites as such areas can be put to no other profitable use. Pond construction on predominantly sandy soils would however be extremely expensive and involve high operational cost and should therefore be avoided. Fish ponds may be considered as an intermediate step in the development and utilisation of non-agricultural land, through fish culture, for cultivation of agricultural crops in future.

Broadly soils can be classified into three categories viz., sand, silt and clay, depending upon the size of the grain of the soil. The permeability of cohesive soil is, in general very little. Sands drain readily while silt and clay are difficult to drain. Clayey soil has a very good capacity of retaining water and in this respect such soil is the best of all. Clay can be identified by its sticky and plastic properties and special odours. When dry, clay forms hard lumps which cannot be broken down and powdered between fingers. Clay is very absorbant and it tends to hold free water. Colour of clay may be black, white, red or yellow. On the contrary, a sandy soil if squeezed in hand when dry, will fall apart when the pressure is released, while moist, it will form a cast but will crumble when touched. Ponds should not be constructed over sandy soil because sand is too porous to retain water. If the selected site is poor in water retentivity, clay has to be brought from elsewhere and a clay coating and puddle core has to be provided to make the ponds retain water. Large quantities of cowdung and hay help in improving the water retention capacity of

poor soils. While soil fertility is important, the very idea of utilising poor and unproductive soils is defeated if fertile soils are selected for pond construction.

---

## 10.5 TOPOGRAPHY

---

The surface feature of the selected site is very important from the point of economy of construction. The ideal topography of a fish farm site is a gently sloping terrain of a wide valley, or a bowl shaped area with high lands on three sides and a narrow outlet on the fourth, as it would keep the cost towards excavation of earth to the minimum. Such a place can be chosen for constructing the farm, provided the desirable type of soil and suitable water supply are available. Such an area can be easily converted into a large pond by erecting an embankment for closing the outlet. Dressing up the bottom to bring it to a uniform depth and sealing the bottom to prevent leakage may be necessary. The type of farm to be constructed in a terrain would depend upon its topography. The site should be so selected that the earth available by excavation should, as far as practicable, balance with the earth required in filling or raising dykes or bunds. Thus prior to designing and construction. The site should be thoroughly surveyed to determine the topography and land configuration.

---

## 10.6 WATER SUPPLY

---

The availability of adequate supply of water is an important requisite for sites selection. There should be sufficient water to fill the ponds and maintain water level in such a way that it does not fluctuate more than 60 cm. Care must be taken to avoid excess supply of water. The dependable sources of water supply are lakes, reservoirs, springs, rivers, streams, canals, surface run off from rain-fall and wells. Any of these would be suitable provided control of the supply is possible and water is not contaminated. A source of water supply to fill the ponds against losses due to seepage and evaporation is therefore essential and should be ready at hand. Areas with sufficient rainfall, high water tables and water retentive soils do not need a stand by source of water supply. However it should be borne in mind that the annual average rate of evaporation alone is on the order of 2 m. Sky ponds must, however, be protected against over flooding during heavy rain.

Big tanks, reservoirs and lakes are perhaps the best source of water. Dams provide the cheapest water for the farm. The water of rivers, supplied by canals is also a satisfactory and dependable source.

Sometimes streams are satisfactory source of water for small ponds provided they meet the following requirements :

1. The flow is adequate enough to fill the pond and maintain a constant water level.
2. The stream is not subject to excessive flooding.
3. The watershed is well vegetated and the stream carries a light silt load and remains fairly clear even during the rains.

Run off from catchments depend on a number of factors such as intensity and duration of rainfall, area, the shape and the contour of the land, initial stage of wetness, losses from evaporation, transpiration by vegetation etc., So it would be difficult to find suitable formulae for calculating the run-off that would hold good for all catchment areas. Nevertheless it may be grossly assumed that for good clayey soils the drainage area required to maintain satisfactory water level in an acre pond could vary from 1.6 to 3.2 ha of pasture land and from 2.4 to 6.4 ha wood land where the pond contains from 1.25 to 1.75 m of water.

## 10.7 DESIGNING

The survey reports relating to type of soil, topography, water supply etc. should be studied before designing fish ponds. The whole design and layout of ponds and dykes will follow on the basis of these survey reports and maps. The design of a pond would include the slope, height and top width of the width of the dyke or bundh and provision of an outlet, in case of large ponds spill way. An impervious column of clay core in the centre will form a part of the design of the dyke when the selected soil is poor in clay content.

While designing a carp culture farm with nursery, rearing and stocking ponds, the following points should be borne in mind in addition to the study of survey reports and maps.

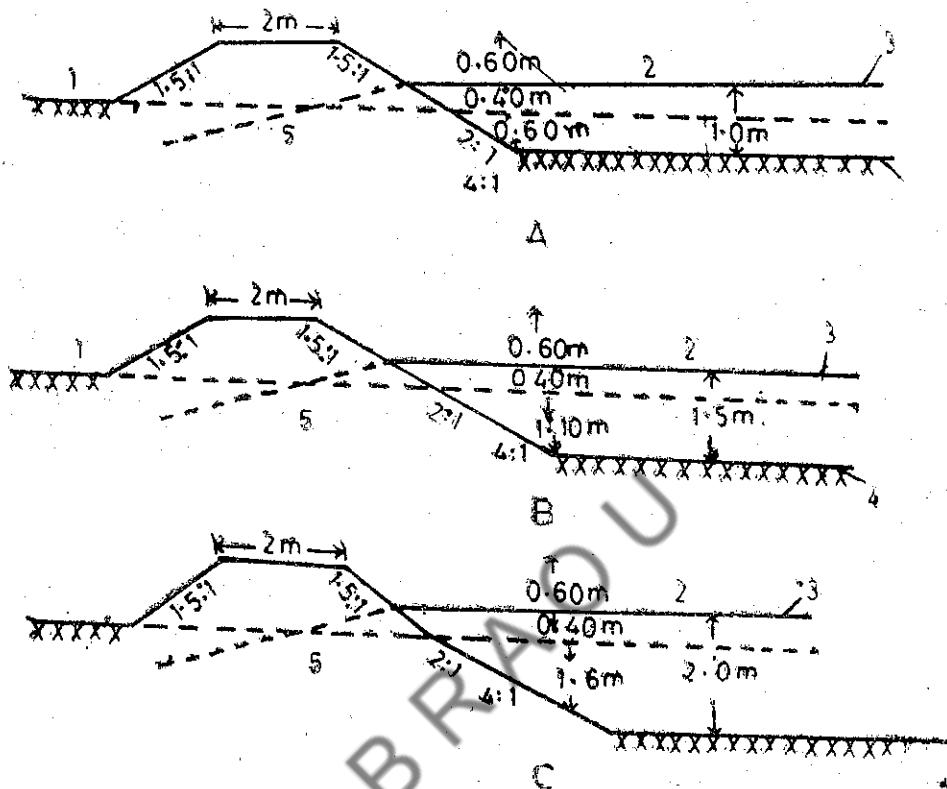

Fig. 10.1 A. Typical section of a nursery pond. B. Typical section of rearing pond C. Typical section of a stocking pond 1. Ground level 2. Free board 3. Water level 4. Pond bottom 5. Hydraulic gradient slope.

- (i) The ratio of water area among nursery, rearing and stocking ponds largely depend upon the purpose of the farm. In case the fish farm is meant for the fish seed production only, nursery and rearing ponds should be constructed leaving a nominal area for stocking the breeders and donors. If the farm is constructed to produce the table size fish alone, only the stocking ponds with fingerlings. If the farm is a composite farm intended to produce both the fish seed as well as the table size fish the ratio of nursery, rearing and stocking ponds will depend up on the intended stocking density. In a composite form it is profitable to sell the part of the seed produced in the farm instead of stocking the whole quantity of seed in the stocking ponds.
- (ii) Nursery, rearing and stocking ponds should be designed according to the sizes and depths as mentioned earlier in this unit. The ponds should be designed in such a way that they are rectangular in shape and the width of the pond should not exceed 40m.

- (iii) The slope of the dyke depends on the type of the soil and its height. Ordinarily, the slope of the dyke of a nursery, rearing and stocking pond may be 1 : 1, 1 : 1.5-2.0 and 1 : 2.0-2.5 respectively. This means that for every meter of dyke height, 1 to 2.5m of dyke base is necessary. The slope is however increased if the soil is silty - sand or loam. A top width of 1 m for nursery and rearing ponds and 2-3 m for stocking ponds may be provided to prevent over flooding and damage to the dyke. Hume pipes width 20-30 cm diameter installed at the desired height through the cross section of the dyke, would serve the purpose. The bottom of the ponds should be gently sloping towards the outlet.
- (iv) When a rain fed pond will contain water to its desired depth, that part of the water volume will be retained by the side of the embankment. Cross section of the embankment should be designed in such a way that it can easily bear the pressure of water standing on the side slope of the embankment without allowing the water to pass through it by percolation or seepage.
- (v) Side slopes of embankment depends upon the nature of the material used for construction. Slopes should be flatter than the angle of repose i.e. the angle at which the material can rest when wet. A flatter slope may be necessary on the rear side to keep the earth work above the line of saturation.
- (vi) Embankment of the fish pond should be designed in such a way that its height from the bottom of the pond should be 2.7 m to 3.65 m. A 0.6 m free board height should be left between the water surface area and crest of the embankment. The free board is essential to prevent the pond spilling over due to sudden and exceptional downpours.
- (vii) The top width of the embankment should not be very narrow. A wide top has the advantage of being raised up during emergencies and also provide material for closing of breaches or filling up scour holes. It will also be easier to carry the load of harvested fish over the embankment by trolley or push cart if the crest is wide. For depth of water from 1.5 to 3.0 m, top width of the embankment can be kept as 1.2 m. But if light vehicles such as jeeps ply over the dykes then its minimum height should be 3.0 m.
- (viii) Ponds should have controlled inlets and outlets, so that these can be filled in and drained out easily. Even pond may have independent drainage or the drainage arrangement may be interconnected for a series of ponds of the same type.
- (ix) A mechanical spill way is necessary for all stocking ponds with watersheds of over 4 ha. Therefore a spill way has to be designed in such a way that it handles all the normal flows and acts as a safety outlet during heavy rains preventing ponds from flooding.
- (x) Seepage of water through the embankment lowers the volume of water stored in the pond and also reduces the stability of the embankment. To prevent the seepage flow, core wells of puddle clay should be designed. The core also would provide a barrier to the passage of burrowing animals. The core wall should generally be located in the centre of the embankment, though it can be present at the water side also.
- (xi) The puddle core work is generally 1.25 to 2.5 m wide at the top and both sides better outwards by about 1 in 12 or 1 in 10 to the ground level a suitable groove or nose should be designed into which the puddle core is keyed.
- (xii) The layout of ponds should be as per the land configuration and the contours. The deeper ponds should be placed on the lower contours, so that lesser earth work is involved.

---

## 10.8 CONSTRUCTION

---

After the designing of a fish farm is completed the detailed estimates of the items of work to be carried out as per the blue print or design should be prepared. The following points should be borne in mind at the time of construction of a fish farm :

- (i) From the point of view of pond management the time of construction of fish ponds is an important factor. The most desirable time to complete the construction of a pond is late summer, so that the pond may be filled immediately by rain water during monsoon. If a pond is constructed during winter or early summer and is not filled with water immediately, weeds may grow and may cover the pond bottom.
- (ii) All trees, shrubs and rank vegetation should be cleared first, as, after decay, these constitute dangerous pockets where leakages develop. The top soil may then be scrapped off and collected at one place to be used later for dressing. Even the roots of the trees should be removed. No woody material should be left because the same will eventually rot and may later produce leakages. Trees and bushes should be cut on the banks about 5 metres from the pond water line to facilitate proper sunshine over the water area and to prevent leaves of the trees from falling into the water.
- (iii) The dyke bases are marked off and, if the soil is impervious, excavation may be started to fill the area. If the soil is highly clayey, sand should be mixed with it to prevent cracking. If the soil is porous, a trench is dug in the centre of the dyke base along its entire length having the same clay core has to be as high as the water level in the pond. A 1m wide beam would add to the stability of the dyke.
- (iv) The excavation of soil can be carried out either by manual labour or by using a bulldozer. If a bulldozer is used, the final shaping should be given by manual labour. The sides and bottom of the pond should be properly finished and rammed to proper level, as per the drawing and design.
- (v) The dyke is gradually raised by laying 15 cm layers of earth along its whole length at a time after the removal of the top soil to a depth of 30 cms the outlined area. This top soil generally contains large amount of roots and other organic materials that would prevent a good bond. For every layer of 15 cm height the earth should be consolidated by watering and ramming till it reaches its full height. However, an allowance of 20 cm should be given for settling for every meter of dyke height. The earth work for the dykes should be thoroughly compacted so that even minor seepage can be checked. The sides and the top of the dykes should be nicely finished with wooden thappies.
- (vi) A firm and sufficiently wide berm adds to the stability of the embankment. If the berm is not wide enough the side slope of the pond will give way and collapse due to the vertical load of the embankments. A wide berm is also helpful for operating a net in the ponds. For an ordinary pond the berm width can be kept at 1.2 m.
- (vii) The dykes of a ponds should be strong enough to withstand weather action. For big ponds erosion of dykes is a problem, which requires regular attention. To protect the embankment from erosion grass turfing is essential. Stone pitching may also be done with a slope of 1 1/2 to 1 or 2 to 1 for ordinary soils but it will be costly. Brick pitching may also be done to protect the slope of the embankment from erosion. Otherwise, after monsoon is over the embankment should be redressed by applying new earth over it. Earth should not be taken from the pond bottom since it will carry a good percentage of silt. Silt laden earth is non-cohesive and unstable, if applied on the slope of the embankment it is likely to be washed back again into the pond or blown back by the wind.
- (viii) Proper drainage arrangement should be provided so that the fish pond can be emptied and filled whenever necessary. In a fish farm where large number of ponds are provided the drainage arrangement may be independent or inter-connected. The drainage arrangement may be provided by constructing suitable channels and each pond may be connected with a channel through a properly constructed sluice gate.

For completely draining the pond, pipes can also be installed. The sizes of the drain pipes needed, depends upon the size of the pond and upon the volume of water running into the pond. A 10 cm drain pipe will empty an acre pond having a maximum depth of 2.7 m and an

average depth of 0.9 to 1.2 m in about 60 hours if no water enters the pond during this period. A 15 cm drain pipe will empty the same pond in half the time. In a majority of cases a 10 to 15 cm drain pipe, will satisfactorily drain ponds upto 3 acres in size. The drain pipes should be installed at the lowest point of the pond so that the entire water can be let out. Different types of drain pipes may be used, of which asbestos cement pipes, concrete spun pipes, cast iron pipes and galvanised iron pipes are more common. A screen should be fitted as the mouth of the pipe to prevent fish from escaping along with water. A brick lining should be made under the pipe so that the overflowing water does not erode away the earth of the embankment.

---

## 10.9 MAINTENANCE OF THE POND

---

Sometimes the burrowing animals such as rats or crabs make holes underneath the ground level joining upstream and downstream of the embankment. To close such leakages, ghog trenches should be cut parallel to the toe line of the embankment. Depth should be such that the mouth of the ghog falls within the trench. The holes should be filled up immediately with stiff clay or clay mixed with lime or other cementing material and should be compacted properly. Though costly, pitching with concrete blocks, stones or bricks will protect the earthen dykes more or less permanently from such crab holes or rat holes.

Leakages, if any should be detected. If the water flowing through a leak is sluggish and closer, it may be a seepage of water and there may not be any immediate danger but a muddy water flowing with some force shows that the soil particles of the bank are being washed away and this needs immediate attention. Correct location of hole on both sides of the embankment is essential which may not always be perpendicular to the embankment. If the hole is small, heavy turf sods are thrown on the surface of the water and they are attracted towards the leak and may come out at the rear. There is a whirling action in the water just above the leakage hole if it is of a big size.

Leakages can be closed by throwing saw dust, bran etc. Just upstream of the leaks. The stuff is carried by water into the leaks where it swells and stops the leaks.

Instead of minor leakages sometimes there may be major breaches which may cause severe breakage of the embankment. To close the breach, labour and material should be collected at the site in sufficient quantity. The ends of the banks should be protected first to prevent further widening. A semi circular bundh may be constructed on the water side with brush woods, bamboo matreses. Sand bags and the matter bailed out. Gradually after that earth is dumped on the breached portions and sand bags are also dumped within deposited mass of earth that act as core and stabilise the embankment.

The pond gradually gets silted at the bottom which constitutes a great hazard to the fish life at times. In order to maintain the desired water depth and reduce risks to fish life, the pond may be dewatered and desilted every three to five years. The bottom silt is a rich fertilizer and may be used for horticulture but it should never be used for repairing the dykes as it is unstable. It should not also be deposited on the dyke to raise its level as sooner or later it will once again find its way back into the pond. Repairs to the dykes must be taken up seriously by completely removing the loose soil and replacing it with fresh dry soil layer by layer. Patch work is never helpful as results in breaches.

### Check Your Progress

1. Write few lines about 'stock ponds'

---

## 10.10 SUMMARY

---

The selection of site, design and construction of ponds are described here. Selection of a suitable site for developing fish ponds is very essential. Even the type of soil is also important as its pH

plays a vital role in fish development. Proper water supply to the ponds is also explained here and if the water resource is not good it becomes fatal for the fish. Design in construction and maintenance of the ponds are also explained here.

---

### 10.11 CHECK YOUR PROGRESS - MODEL ANSWERS

---

1. Stock ponds are larger than the rearing ponds. They differ in size from 0.2 ha to 2.0 with a depth of 2.0 m to 2.5 m. It is desirable that the stock pond is more than 0.5 ha in area. These ponds are utilized for stocking the finger lings in order to obtain table size fish. They should be perennial.

---

### 10.12 MODEL EXAMINATION QUESTIONS

---

#### I. Answer the following in about 30 lines :

1. Describe the different types of ponds suitable for carp culture.
2. What are the vital considerations for the site selection ? Give an account on the type of soil suitable for pond construction.
3. Write a detailed note on the water supply for the farm ponds.
4. Explain the important aspects designing of ponds.
5. Describe the different steps in the construction of fish farm.

#### II. Answer the following in about 10 lines :

1. The topography of selected site for farm pond construction.
2. Maintenance of the pond.

Dr. BRAOU  
LIBRARY

Acc. No. 21503  
Class No. 591  
200

75

---

# UNIT - 11 FARM POND : WATER AND SOIL QUALITY, FOOD CHAIN AND PRODUCTIVITY

---

## Contents

- 11.1 Objectives
- 11.2 Introduction
- 11.3 Water Quality
- 11.4 Organic Matter
- 11.5 Soil Quality
- 11.6 Chemical Condition of Soil
- 11.7 Productivity
- 11.8 Concept of Productivity
- 11.9 Classification of Water bodies on the basis of their productivity
- 11.10 Summary
- 11.11 Check Your Progress - Model Answers
- 11.12 Model Examination Questions

---

## 11.1 OBJECTIVES

---

In this unit the physico-chemical features of water and soil and the characteristics of water and soil that are required for fish pond are discussed. The ecological phenomena that occur in the pond environment like food chain and productivity which are directly related to fish production are presented.

---

## 11.2 INTRODUCTION

---

Physical conditions of water like depth, temperature, turbidity and light were dealt with. Chemical conditions of water like dissolved oxygen, carbon dioxide, total alkalinity, pH, total hardness, dissolved solids, inorganic compounds (nitrogen, phosphorus, iron, calcium and magnesium, sodium, potassium, sulphates, silica, trace elements) and organic matter were described. Biological conditions of the pond like aquatic vegetation, plankton, and Benthos were described. Various types of pond soil viz., Alluvial soil, Black soil, Red soil, Lateritic soils, Forest soil, Desert soil, Saline and Alkaline soils and peat were described. Chemical conditions of the soil viz., Hydrogen ion concentration, Phosphorus, Nitrogen, Organic Carbon, Potassium and Calcium were given. Food chain in aquatic systems comprising of pyramid of production rates, Pyramid of biomasses, and Pyramid of numbers were described. Various concepts of productivity like standing crop, rate of removal, rate of production were discussed. The water bodies were classified on the basis of their productivity.

---

## 11.3 WATER QUALITY

---

The primary requisite for fish culture in ponds is the water, which, for successful rearing of fishes should offer the most favourable conditions for the existence not only of fish but of other aquatic organisms as well, which form the food of fish.

### Physical Condition of Water

Depth, temperature, turbidity and light constitute the more important physical parameters on which the productivity of a pond depends.

#### Depth

Depth of a pond has an important bearing on the physical and chemical qualities of water. On depth and turbidity depend the limits of penetration of sunlight which, in turn, determines the temperature and the circulation pattern of the water and the extent of photosynthetic activity. In shallow ponds, sunlight penetrates upto the bottom, warms up the water and facilitates increase in productivity. A depth of about 2 metres is considered congenial from the point of view of biological productivity of a pond.

#### Temperature

The degree and annual variation in temperature of a water body have a great bearing upon its productivity in general. All metabolic and physiological activities and life processes such as feeding, reproduction, movement and distribution of aquatic organisms are greatly influenced by water temperature. Temperature also affects the speed of chemical changes in soil and water, decrease with a rise in temperature. Temperature shows diurnal as well as seasonal variations. A prior knowledge of maximum and minimum water temperature of a body of water is essential for selecting suitable species of fishes for cultural operations.

#### Turbidity

The turbidity of natural waters may be either due to suspended inorganic substances such as silt and clay or due to planktonic organisms. It is an important limiting factor in the productivity of a pond. Turbidity varies greatly with the nature of the basin, degree of exposure, nature of in flowing sediments etc. Ponds with clay bottoms are likely to have low turbidity. Turbidity may be temporary caused by rains, floods etc., or perennial based on the nature of the basin and continuous wave and wind actions. Turbidity due to profusion of plankton is an indication of pond's high fertility but that caused by silt or mud beyond a limit, is harmful to fish and fish food organisms.

Turbidity restricts the penetration of sunlight and hence reduces photosynthetic activity, which in turn, affects the productivity of a water mass. The Indian major carps and other culturable plain dwelling fishes tolerate the prevailing high ranges of turbidity (i.e. 2,000 ppm.) Fishes dwelling in turbid waters show a number of adaptations. They have greatly reduced eyes and mucous secreted by their skin possesses the property of rapidly sedimenting the particles suspended in water.

Light penetration depends on the available intensity of the incident light which varies with the geographical location of the pond. Shade provided by the surrounding vegetation affects the incidence of light on the pond. Light penetration in water is also affected by the prevailing turbidity.

## Chemical Conditions of Water

Gases, solids and nutrients dissolved in water and its pH constitute the chemical characteristics of a pond.

### Dissolved Oxygen

Of all the dissolved gases, oxygen is the most important in natural waters for the life of the fish. The pond water receives oxygen mainly through two sources - (i) by absorption from the atmosphere at the surface of the pond and (ii) by photosynthesis of the chlorophyll bearing organisms inhabiting the pond. Photosynthesis is a physiological process of carbon assimilation by plants occurring in the presence of sunlight. During day time, plants, in the process of photosynthesis, release oxygen while consuming carbondioxide. At night, when photosynthesis ceases, the plants consume oxygen and release carbondioxide through respiration. The animal community, residing in the pond, requires dissolved oxygen for respiration and releases carbondioxide both during day and night. Oxygen consumption in a body of water occurs by the respiration of animals and aquatic plants as well as by the putrefaction of organic matter. Oxygen consumption in a body of water occurs by the respiration of animals and aquatic plants as well as by the putrefaction of organic matter. The oxygen available in the water at a given time is the balance of the above processes. Ideally, the oxygen-producing and oxygen-consuming processes in natural waters should be balanced so as to keep the dissolved oxygen concentration within a range congenial to all organisms.

### Carbon dioxide

Carbon dioxide in natural water is derived from (i) the atmosphere, (ii) respiration of animals and plants, (iii) bacterial decomposition of organic matter, (iv) inflowing ground waters which seep into the ponds, the amount of  $\text{CO}_2$  depending upon the decomposition of the top soil and chemical nature of the underlying rocks and (v) finally from within the water itself in combination with other substances chiefly calcium and magnesium. The atmosphere furnishes some carbondioxide to natural waters by direct contact. Rain, as it precipitates on earth, absorbs small amounts of the gas and delivers it to the waters on which it falls. Rain water contains about 0.3 ml or 0.6 mg. per litre of dissolved carbon dioxide.

### Total Alkalinity

The total alkalinity of water is mainly caused by the cations of Ca, Mg, Na, K,  $\text{NH}_4$  and Fe combined either as carbonates and/or bicarbonates or occasionally as hydroxides. Hydroxide alkalinity generally occurs in polluted waters. In other waters it is occasionally encountered during mid-afternoon in surface layers in waters showing intense photosynthesis. A mixture of bicarbonate and carbonate alkalinity is generally encountered in waters of pH ranging from 8.4 to 10.5. Bicarbonates are reduced in higher pH values. At pH values less than 8.3 but more than 4.5, practically no carbonate is present, but free  $\text{CO}_2$  and bicarbonates may be present. Total alkalinity is a measure of productivity. In highly productive waters, the alkalinity ought to be over 100 ppm. Many rivers and fish ponds fall within the local alkalinity values equivalent to 10-50 ppm  $\text{CaCO}_3$ .

### PH

The hydrogen-ion concentration, or pH, of natural waters is an important environmental factor, the variations of which, among other causes, are linked with the species composition and life processes of animal and plant communities inhabiting them.

Waters having a pH range of 6.5 to 9.0 as recorded before day break are most suitable for pond culture and those having pH values of more than 9.5 as unsuitable, because  $\text{CO}_2$  will not be available at high pH values. Fish dies at about pH 11. Acid waters reduce the appetite of

the fish, their growth and tolerance to toxic substances. The toxicity of  $H_2S$ , copper and other heavy metals to fish is increased by lowering the pH. Acid waters may indirectly influence other aquatic organisms by similar harmful effects, thus weakening its biogenic capacity. The fish gets prone to attacks of parasites and diseases in acid waters.

### **Total Hardness**

Hardness is the total of soluble Ca and Mg salts present in the water. Expressed as its  $CaCO_3$  equivalent. Total hardness also includes the sulphates and chlorides of Ca and Mg.

Total hardness is used to classify waters as 'hard' or 'soft'. Soft water contains small amounts of Ca and Mg in solution and in which the average bound  $CO_2$  does not exceed 5 ml. per litre. Medium water contains bound  $CO_2$  between 5 and 22 ml. per litre. Hard water contains more than 22 ml. per litre of bound  $CO_2$ , which may even exceed 50 ml. per litre.

Free  $CO_2$  at a concentration of more than 15 ppm, is detrimental to pond-fishes. The air breathing fishes can, however, survive 100 ppm of  $CO_2$ .

### **Dissolved Solids**

All waters in nature contain both aquatic and inorganic dissolved solids. The inorganic solids when in solution consist of anions like carbonates, chlorides, sulphates, phosphates, nitrates etc., in combination with metallic cations like Ca, Na, K, Mg, Fe etc. The organic compounds which occur as dissolved solids are the organic state of phosphorus, nitrogen, sugars, acids and vitamins. The dissolved solids in a water mass influence the chemical density of the environment and abundance and composition of the biotic community.

The total concentration of dissolved solids in a water body is a useful parameter in describing the chemical density as a fitness factor and as a general measure of edaphic relationship that contributes to the productivity of the water.

## **INORGANIC COMPOUNDS**

### **Nitrogen and its compounds**

Nitrogen occurs in natural waters in elemental (or uncombined) state and as organic as well as inorganic nitrogenous compounds. The elemental nitrogen in water is derived mostly from the atmosphere, the other source being bacterial denitrification of nitrates, nitrites and ammonia. The solubility of nitrogen in freshwater varies with temperature (inversely) and pressure. Under certain pressure conditions, supersaturation of nitrogen can occur at the air water interface which at times cause 'gas bubble' disease in fish, a physiological condition also caused by supersaturated oxygen.

Nitrogen is a very important element in pond fertility.

### **Phosphorous**

Although phosphorous occurs in natural waters in very small quantities, the element is recognized to be the most critical single factor in the maintenance of pond fertility. The element does not occur in nature, the most abundant mode of occurrence being in the form of phosphates.

Phosphorus shown seasonal variations in fish ponds and the mineral gets removed when the fish or the vegetation are taken out of water. Lack of phosphorus is often the chief cause of poor productivity of waters. Natural waters having a phosphorus content of more than 0.2 ppm  $PO_4$  are quite productive. Excess of phosphate in open waters is a sign of heavy organic pollution.

## Iron

Iron occurs in natural waters either as bivalent ferrous or trivalent ferric form.

## Calcium and Magnesium

These two elements together form the most abundant ions in fresh waters. Ponds with less than 10 mg. per litre of calcium content are considered biologically 'poor' (soft) while between 10 to 25 mg. per litre as 'medium' and above 25 mg. per litre as 'rich' (hard). It makes soil to release phosphorous into the over lying water, which would otherwise remain soil bound, unavailable for aquatic productivity. Calcium is also useful in counteracting the toxicity of excess of some metabolic ions.

Magnesium is essential for chlorophyll bearing algae and plants. It is generally present in waters as bicarbonate and in this form it resembles calcium bicarbonate in reactions with water.

## Sodium and Potassium

In natural waters sodium occurs as halide ( $\text{Na Cl}$ ), sodium tetraborate ( $\text{Na}_2\text{B}_4\text{O}_7$ ) or borax and sodium sulphate ( $\text{Na}_2\text{SO}_4$ ). Sodium is metabolised only by blue green algae but potassium is a necessary requirement for all algae. Under low potassium conditions, growth and photosynthesis of algae are poor and respiration is high.

## Sulphates

The most abundant form of sulphur is the anion sulphate occurring in combination with the commonly encountered cations in fresh waters, such as calcium, potassium, iron etc. Sulphur also occurs in water as hydrogen sulphide ( $\text{H}_2\text{S}$ ).

Sulphate is ecologically important for growth of plants and its short supply may inhibit the development of plankton. Sulphur is also important in protein metabolism.

## Silica

Silica occurs mainly as orthosilicate in an undissociated condition at the naturally encountered pH value of natural waters. The element is most abundant in sedimentary rocks, and, therefore, occurs generally in higher concentrations in waters located in such regions. Surface waters of open ponds contain about 79.5 mg. per litre of silica.

## Trace elements

There are certain elements called trace elements or minor elements which, even though occur in extremely small amounts, are of great significance in imparting productivity to waters.

## Manganese

Manganese is commonly found in natural waters.

Manganese plays an important role in photosynthesis and in heterotrophic growth of phytoplankton.

## Copper

It occurs in three forms soluble or ionic, organic or colloidal and in suspension. The organic form of copper is the most important. The element copper, though a micro-nutrient is used for the control of algal blooms.

Besides, manganese and copper, there are other trace elements like zinc, aluminium, cobalt etc. present in water.

---

## 11.4 ORGANIC MATTER

---

Organic matter present in natural waters in solution is organic phosphorus, organic nitrogen, carbohydrates, Vitamins etc. That present in suspended states comprises the seston. The bottom sediments also contain abundant organic substances. The organic matter of a water body may be either allochthonous or autochthonous in origin and may be in dissolved or suspended states.

### Biological Condition

Pond biota consists of plant and animal communities, essentially of the littoral and benthic types which form the biological basis of pond productivity.

### Aquatic vegetation

In ponds four zones of aquatic vegetation are distinguishable. Viz., (i) bottom zone of vegetation, (ii) zone of submerged rooted aquatics, (iii) zone of unattached submerged free floating vegetation, and (iv) zone of surface vegetation.

The bottom zone of vegetation occurs on clay or silt which sustains species of sulphur and iron bacteria, flagellates, blue green algae and diatoms. This zone constitutes the vital layer since the inhabiting organisms act as active agents in decomposing the plant and animal matter setting down at the pond bottom.

The zone of submerged rooted aquatics consists of higher phanerogams, eg. *Vallisneria*, *Hydrilla*, *Najas* etc. The zone of unattached submerged free-floating vegetation consists of forms like *Ceratophyllum*, *Utricularia* etc., The zone of surface vegetation consists of microscopic or higher aquatic plants which float on the water. The microphytoplankton consists chiefly of algae such as *Microcystis*, *Chlorella*, *Euglena*, zoospores of various green algae, like *Spirulina*, *Anabaena*, *Volvox* etc. The floating higher aquatic plants comprise forms like *Eichhornia*, *Pistia*, *Lemna* etc.

Towards the margin of a pond, rooted aquatic plants such as *Nymphaoides*, *Nymphaea*, *Chara*, *Nitella* etc. Commonly occur. There are some amphibian plants capable of growing on moist lands as well as floating on the water surface such as *Enhydra*, *Ipomea* etc.

### Plankton

Free floating organisms in water comprise two groups, viz., plankton and neuston. Plankton is defined as free floating animal and plant organisms moving at the mercy of currents and waves. Neuston comprises organisms which are related to the surface film of water, either (i) by hanging or floating against the lower side (eg. bacterial, protozoa, algae, entamostraca, insect larvae etc.) or (ii) by hanging upon the surface film (Gerridae, Veliidae, Gyridae etc.)

Plankters, according to their quality, may be classified as: (i) Phytoplankton and (ii) Zoo plankton. Phytoplankton consists of chlorophyll bearing organisms, e.g., *Microcystis*, *Volvox*, etc., and the non-photosynthetic plants or saproplankton, e.g., bacteria and fungi. Zooplankton consists of plankters of animal origin.

Water blooms (caused by phytoplankton) besides imparting colour to water, also bestow a disagreeable smell and taste to it. Algal blooms often cause a heavy mortality of fish, the mortality being variously attributed to depletion of oxygen by algae during continuous cloudy weather, to their decomposition, to the physical choking of the gills of the fish and to toxic substances liberated by the metabolism of the algae.

phase under either condition. Available soil phosphorus shows a definite positive correlation with fish production.

### Nitrogen

The organic matter occurring in pond bottom is broken down by number of microorganisms. The end products of this decomposition among others are  $\text{CO}_2$  water and ammonia. While ammonium salts are formed a number of bacteria found in the soil and water convert ammonia nitrogen into nitrates. Nitrates and ammonium salts are reduced to free nitrogen through the agency of denitrifying bacteria.

### Organic carbon

When organic fertilizers are applied to a pond, their assimilation the pond body may take two paths in its trophic cycle. Firstly, the organic fertilizers may be broken down directly through the agency of micro organisms into soluble simple (inorganic) compounds which are then recirculated through autotrophic bacteria and green plants. Secondly, they may be used as complex compounds (the cell substance of the primary heterotrophic bacteria involved in decomposition) directly as food by higher forms (such as protozoa and other zooplankton) and returned more rapidly to fish crop. In the latter case, where the initial food shelf is bacterial cell substance, nitrogen is transferred quantitatively from the fertilizer to the fish crop.

### Potassium

Potassium is taken up readily by submerged weeds for growth. During rapid plant growth period, potassium from the water and soil is stored in tissues. Ponds with sandy, non adsorptive soils are usually potassium poor and respond most markedly to fertilization.

### Calcium

Calcium is considered important owing to its four main roles; (i) its relation to translocation of carbohydrates, (ii) as an integral component of plant tissue, (iii) for increasing the availability of other ions and (iv) for reducing the toxic effect of single salt solution of other elements. In pond soil, calcium is generally present as  $\text{CaCO}_3$ .

---

## 11.7 PRODUCTIVITY

---

The productivity of a water body connotes a characteristic whereby living substance is manufactured through interactions of the constituent of the natural environment. Some ecosystems like ponds are essentially self sustaining. The various steps in the operation of a self contained ecosystem are: (i) the reception of energy; (ii) production of organic material by producers, (iii) consumption of this material by consumers and its further elaborations; (iv) decomposition to inorganic compounds and (v) transformation into suitable forms for the nutrition of the producers. In a self sufficient ecosystem, all these steps are contained within it.

The non-living constituents are light energy and inorganic nutrients both required for the growth of photosynthetic plants.

The living components of the ecosystems consist of producers and consumers. Producers include the chlorophyll-bearing phytoplankton large green plants and photosynthetic bacteria, which are capable of synthesizing energy containing organic substance through utilization of solar radiation and inorganic materials. The consumers include all other types of organisms in the community. These organisms are incapable of synthesizing organic matters from solar energy and depend directly or indirectly upon the producers. With in the category of consumers are included herbivores which feed directly on the green plants, or other carnivores. Decomposers

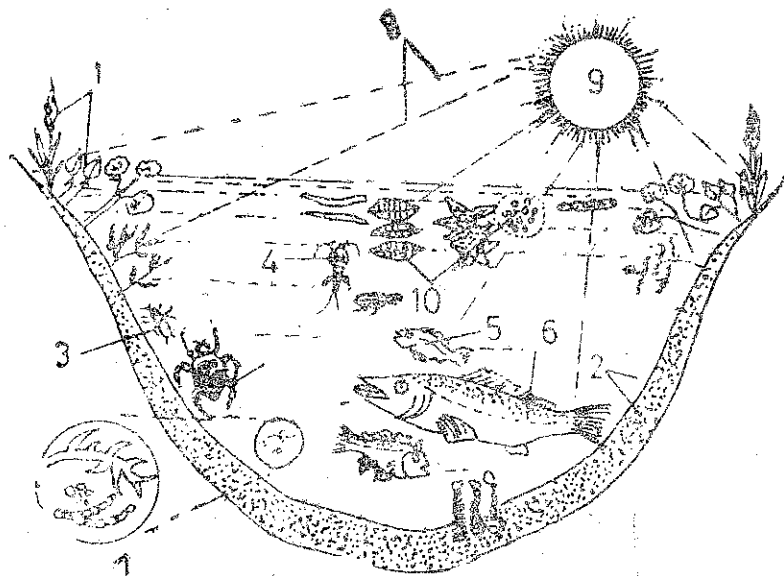

Fig.11.1. Diagram of the pond ecosystem. Basic unity are as follows. 1. Producer rooted vegetation 2. Abiotic substance-basic inorganic and organic compounds 3. Primary consumers (herbivores) bottom forms 4. Primary consumers (herbivores) Zooplankton 5. Secondary consumers (carnivores) 6. Tertiary consumers (secondary carnivores) 7. Saprotrophs bacteria and fungi of decay. 8. Sun-rays 9. sun-energy 10. Producer (phytoplankton).

are the heterotrophic bacteria and fungi which reduce organic substances to their elemental state, thereby utilizing the nutrients into the cycle for use by producers. The plants and animals that depend successively one upon the other form the links of a food chain. Each successive level of nourishment as represented by two links of the food chain, is known as a trophic level.

## FOOD CHAIN

The plant producers within an ecosystem constitute trophic levels: (1) grazing herbivores; (2) small-sized carnivores (3) medium and large carnivores (4) additional links in the food chain. The side chains such as those formed by parasites, make further trophic levels. Three types of pyramidal relations may be found among the organisms at different trophic levels, which are (i) the pyramid of production rates, (ii) the pyramid of biomasses and (iii) the pyramid of numbers.

### (i) Pyramid of production rates

At each level in the trophic chain, there occurs some loss of energy and material from the system because processes of assimilation and growth are not cent percent efficient, i.e., for organic matter produced per average unit of time and the energy represented by it become less at each successive trophic level. It follows that there is a greater amount of energy at the producer level than at the herbivore (primary consumer) level, and this progressively continues to decrease at each successive trophic level. The efficiency of conversion of the energy contained in food to animal protoplasm increase with the trophic level. i.e., it is maximum among carnivores. The production rates of the components of a self sufficient ecosystem may thus be compared to a pyramid. The so called pyramid of energy, represented by the organic synthesis of the green plant component at the base with production rates of primary consumers, i.e., herbivores and those of secondary consumers, i.e., carnivores, resting at successively higher levels.

### (ii) Pyramid of biomasses

The second type of pyramid is formed by the biomass of members of the food chain and is called pyramid of biomass or standing crop. This suggests that the total mass of living

substance tends to decrease from one level to the next in the same way as in other pyramids mentioned above. Factors which are responsible to form such a pyramid interalia include growth rate and density of various population.

### (iii) Pyramid of numbers

The third type of pyramid is formed by numerical count of organisms, implying that there is a decrease in the number of organisms from lower to higher trophic levels. This is caused by differences in the population growth rates and predation of smaller organisms by large ones. In case of parasites, the pyramid of numbers is upside down, being reverse of that pertaining to the free living forms.

In the food chains and webs of a community, photosynthesis forms the base of the ecosystem.

---

## 11.8 CONCEPT OF PRODUCTIVITY

---

Three measures of productivity, namely (i) standing crop (ii) rate of removal and (iii) rate of production, are in common use and form the core of the concept of productivity in an ecosystem.

### (i) Standing crop

The standing crop is the total biomass of the organisms existing in the area at the time of observation and may be expressed as number of individuals, as biomass, as energy content etc. Thus, the standing crop represents an instantaneous quantity of organisms.

The actual, or realized rate of growth, is determined by the initial number of individuals plus additions (natality) minus the number lost (mortality) per unit of time.

### (ii) Rate of removal

Various aspects of the biota removed or harvested from the second measure of productivity. It refers to the yield or harvest from an ecosystem per unit of time.

The emigrations of animal or plant life, predation by terrestrial animals, outflow of organisms through effluent streams, loss of nutrients of sediments, commercial harvesting of fish etc., are some of the ways of removal. If a community is to maintain itself, the loss of material must be compensated by adequate replenishment. The ratio of yield to replenishment is a crucial measure of productivity and indicates whether a given community is over- or under-exploited not only by man but also in respect of predatory-prey relationship and other ecological aspects.

### (iii) Rate of production

Of the total solar energy that enters a pond, a small portion enters into the photosynthetic process of green plants and is stored in organic substance (chiefly carbohydrates) in plant bodies. The energy of carbohydrate formed represents the gross plants production or the gross primary production. Not all the energy present in photosynthetic product takes part in the actual growth of plants since the process involved is not 100% efficient. The accompanying catabolism of the plant is measured by the amount of respiration. Actual plant growth is represented by an amount of energy equal to the total carbohydrate formed minus the respiration and is termed as the net primary production. The amount of plant substance produced per unit of time and space is defined as the rate of gross primary production and the rate of net primary production represents the rate at which organic matter is stored. Both the rates of primary production, i.e. gross and net are measured on the basis of organic carbon (c) present in the unit volume or beneath unit area of the pond surface and are expressed in units  $\text{mg C/m}^3/\text{day}$  or  $\text{mg C/m}^2/\text{day}$ . The word 'day' generally refers to day-light- hours during which gross or net photosynthesis occurs in the surface water.

The secondary production constitutes the energy food actually assimilated by heterophilic organisms, such as primary, secondary and tertiary consumers and the decomposers. The rate of energy storage in these levels is called the rate of secondary production. The rate of production at each higher level decreases from herbivore to top carnivore.

---

## 11.9 CLASSIFICATION OF WATER BODIES ON THE BASIS OF THEIR PRODUCTIVITY

---

The productivity to water bodies can be a measure for their classification, especially with regard to fish yields, on the basis of their water quality. Acid waters (pH 5.5-6.5) and highly alkaline water (pH > 8.5) are unproductive and pH 7.5 to 8.5 may be considered favourable for average production. Total alkalinity below 20 ppm is indicative of poor production and alkalinity above 20 ppm does not influence productivity. Dissolved oxygen below 5 ppm is unfavorable for a productive fish pond. Under normal conditions, concentration of dissolved oxygen above 7 ppm is suitable for a productive water body. Values of dissolved inorganic nitrogen below 0.1 ppm is considered as indicative of poor productivity, those in the range of 0.1 to 0.2 ppm are favourable for productive ponds. Dissolved phosphate (as  $P_2O_5$ ) 0.05 ppm may be considered indicative of an unproductive fish pond; 0.05 to 0.20 ppm of medium to high productivity and > 0.02 ppm. of very high fish productivity. However, due to its quick turnover from water phase dissolved phosphorus may not be a reliable index for productivity.

### Check Your Progress

1. Benthos
2. Peat

---

## 11.10 SUMMARY

---

The quality of water, the physical conditions of water such as temperature, turbidity, light are described in detail. Similarly the Chemical conditions like dissolved oxygen,  $CO_2$ , total alkalinity, pH, dissolved solids, are discussed. Like wise the inorganic compounds like Nitrogen, Phosphorous, Iron, Calcium, Sodium, Potassium, Copper, Silica etc. are also described. Because all these things play a vital role for proper development of fish in ponds. Even the organic matter, like Aquatic vegetation, Plankton, are described in detail as they control the growth of fish populations to a great extent. The soil quality is also discussed. The organic productivity, the Pyramids, food chains are described in detail.

---

## 11.11 CHECK YOUR PROGRESS - MODEL ANSWERS

---

1. **Benthos:-** The community of organisms living on the bottom of a water body is called the benthos. Benthos may be divided into phytobenthos and zoobenthos.
2. **Peat:** The areas of peaty soils have an accumulation of large quantities of water soluble alkaline salts. The water logged areas found by dried river basin and lakes in alluvial and coastal areas are generally blue or blueblack in colour due to the presence of (ferrous) iron and also contain varying amount of organic matter.

---

## 11.12 MODEL EXAMINATION QUESTIONS

---

### I. Answer the following in about 30 lines.

1. Describe the factors affecting the physical conditions of water.

2. Write an account of the role played by any three of the following in maintaining the quality of water :

(a) Oxygen (b) Carbon dioxide (c) Total alkalinity (d) pH (e) Total hardness (f) Dissolved solids.

3. Give an account of the biological component of a water body.

4. Describe the different types of soils present in India.

5. Give an account of the chemical condition of the soil.

6. Describe the different methods for measuring productivity of water bodies.

**II. Answer the following in about 10 lines.**

1. The role of nitrogen and its compounds in the water quality.

2. The role of phosphorus in the water quality.

3. The role of Calcium and Magnesium in the water quality.

4. An account of trace elements.

5. An account of productivity in a water body.

6. An account of food chain in a water body.

BRAOU

---

## **UNIT - 12: FARM POND - POND MANAGEMENT**

---

### **Contents**

- 12.1 Objectives
- 12.2 Introduction
- 12.3 Scientific Management Practices of Farm Ponds
- 12.4 Nursery Pond Management
  - 12.4.1. Pond Maintenance
  - 12.4.2. Control of Aquatic Weeds
  - 12.4.3. Eradication of Predatory and Unwanted Fishes
  - 12.4.4. Pond Fertilisation
  - 12.4.5. Eradication of Aquatic insects
  - 12.4.6. Stocking of Sprawn
  - 12.4.7. Supplementary Feeding
  - 12.4.8. Harvesting
- 12.5 Rearing Pond Management
  - 12.5.1. Pond Fertilization
  - 12.5.2. Stocking of Fry
  - 12.5.3. Supplementary Feeding
  - 12.5.4. Harvesting
- 12.6 Stock Pond Management
- 12.7 Stock Pond Selection and Maintenance
  - 12.7.1. Control of Aquatic Weeds
  - 12.7.2. Eradication of Unwanted Fishes
  - 12.7.3. Liming of the ponds
  - 12.7.4. Pond Fertilization
  - 12.7.5. Chemical Fertilization
  - 12.7.6. Stocking
  - 12.7.7. Supplementary Feeding
  - 12.7.8. Health Protection
  - 12.7.9. Harvesting
- 12.8 Summary
- 12.9 Check Your Progress - Model Answers
- 12.10 Model Examination Questions
- 12.11 Glossary

---

## 12.1 OBJECTIVES

---

This unit deals with the scientific management techniques developed recently to achieve maximum fish production in freshwater pond culture system. This unit describes in detail about the pre-stocking, stocking and post-stocking management practices in nursery, rearing and stock ponds.

---

## 12.2 INTRODUCTION

---

Scientific management techniques of farm ponds were developed to attain maximum fish production. Freshwater carp culture in India is a three-stage culture system, which includes the management of nursery, rearing and stock ponds. Management practices evolved can be broadly grouped under prestocking, stocking and post-stocking operation. Pre-stocking pond management measures include the maintenance of ponds, removal of aquatic weeds, eradication of undesirable and predatory organisms, and fertilization. Stocking phase consists the selection of species, their density and combination. Post-stocking management practices are the supplementary feeding, fish health protection and harvesting. Main aim of nursery pond management is to raise the carp spawn (5 to 6 mm size) upto fry stage (25 to 30 mm size) in fifteen days. Growing of carp fry upto fingerling stage (100 to 150 mm size) in about three months period is the aim of rearing pond management. Fish fingerlings are grown to marketable size in stock ponds with an objective of producing maximum quantity of fish through the most economic management techniques. Adoption of rational management measures makes fish farming a profitable proposition.

---

## 12.3 SCIENTIFIC MANAGEMENT PRACTICES OF FARM PONDS

---

The principal aim of fish cultivation in ponds is to obtain sustained maximum production.

Fishes cultivated in freshwater ponds are constantly under the stress of various ecological factors which affect their survival and growth. Adoption of selective management measures is intended to provide conducive environment so as to achieve high survival rate and rapid growth of the fishes.

Traditional freshwater pond culture system practiced in India merely involved irrational stocking and harvesting of fish without any scientific basis. In this system survival of the fishes was low resulting in heavy loss of valuable seed.

Freshwater pond culture system evolved in India is mainly carp oriented. Species preferred for cultivation are the Indian major carps : catla (*Catla catla*), rohu (*Labeo rohita*), mrigal (*Cirrhina mrigala*) and exotic carps : silver carp (*Hypophthalmichys molitrix*), grass carp (*Ctenopharygodon idella*) and common carp (*Cyprinus carpio*).

Pond management techniques developed cover the entire cycle of fish culture, from hatchling stage to marketable-stage under controlled conditions in a three-tier culture system. The three-stage carp culture system includes the management of (i) nursery ponds (ii) rearing ponds and (iii) stock ponds.

Scientific management practices of farm ponds developed can be broadly grouped under pre-stocking, stocking and post-stocking operations.

Pre-stocking management practices include the maintenance of ponds, removal of aquatic weeds, eradication of undesirable and predatory organisms, improvement of pond water and soil quality and fertilization.

Stocking phase consists evaluation of carrying capacity of the pond, relative density and combination of selected species.

Post-stocking management practices mainly comprise the supplementary feeding, fish health monitoring and harvesting pattern of the crop.

---

## 12.4 NURSERY POND MANAGEMENT

---

Nurseries are small, shallow ponds of 0.02 to 0.08 hectare (200 to 800 Sq. metres) in area with 1.2 to 1.5 metre water depth. Earthen dug out, rectangular ponds of about 0.04 hectare (400Sq. metres) in area are preferable as nurseries.

Raising of three to four days old carp spawn (hatchings measuring 5 to 6 mm) upto fry stage (25 to 30 mm size) in about fifteen days period with maximum percentage of survival is the main aim of nursery pond management.

Objectives of nursery pond management are to provide free moving space to the growing spawn, removal of predatory organisms and to provide sufficient natural as well as supplementary feed for quick growth of spawn.

### 12.4.1 Pond maintenance

In selecting a site for the nursery pond construction, the main consideration to be taken into account are the water retention capacity and fertility status of the soil, an assured water source, protection from flood and inundation and existence of good communication facilities.

Nursery pond must be well exposed to sun light. Embankments of nursery pond may be protected from erosion by turfing. Inlet and outlet facilities must be well protected and nylon mesh filters are to be arranged so that unwanted fish eggs, larvae and other organisms are prevented from entering into the pond.

### 12.4.2 Control of aquatic Weeds

Aquatic weeds in nursery ponds harbour predatory insects and unwanted fishes, and restrict the free movement of spawn and curtail the production of plankton. Hence nursery ponds should be cleared of all aquatic weeds and marginal grass by manual labour. This may be done during summer months (April-May). Nursery ponds should be kept free of weeds till the fry are harvested.

### 12.4.3 Eradication of predatory and unwanted fishes

Carp spawn at the time of release into nursery ponds are delicate, tiny and chances of their survival in the midst of their predators are low. Hence eradication of their enemies forms an important operation in the nursery pond management.

Predatory fishes which cause maximum damage are the *Channa* sps., *Anabas testudineus*, *Wallago attu*, *Heteropneustes fossilis*, *Clarias batrachus* etc. These fishes directly prey on the carp spawn.

Weed fishes are small sized uneconomic varieties of fishes. *Puntius* sps., *Oxygaster bacaila*, *Ambassis ranga*, *A. nama*, *Esomus danricus*, *Amblypharyngodon mola*, *Chela* sps. are some of the weed fishes commonly infecting the nursery ponds. They breed in ponds. Weed fishes compete with carp spawn for the available food (both plankton and supplementary feed) in the pond.

The simplest method to eradicate unwanted fishes is either by complete draining or dewatering of the pond. Another method is to remove the undesirable fishes by repeated drag netting.

Many predatory fishes are bottom dwellers and burrow into mud. These fishes are difficult to net out completely.

The best method to eradicate the predatory and weed fishes is by the use of fish toxicants. Suitable fish poisons are those which kill the fishes at low doses. These should not cause any damage to people and cattle who use the water. The poisonous effect should decrease as quickly as possible and they should be easily available and economical.

Several kinds of pesticides, such as endrin, dieldrin, aldrin, phosphamidon, nuvan, thiometon were tested in nurseries. Though they kill the fishes, these chemicals also adversely affect other aquatic biota and as they are stable compounds they accumulate in fish tissues. Fishes killed by application of pesticides are not suitable for human consumption. Hence pesticides as fish toxicants are not suggested.

Several pesticides derived from plants to eradicate undesirable fishes were also tested recently. Mahua oil cake (*Bassia latifolia*), derris root powder (*Derris trifoliata*), seed powder of *Croton tiglium*, powdered root of *Millettia pachycarpa*, tea seed cake are some of the plant poisons which kill seed fishes, Mahua oilcake kills the fishes within 3 to 6 hours.

#### 12.4.4 Pond fertilization

Fertilization of the nursery pond is the next step and its main objective is to enrich the pond waters to promote growth of zooplankton which is a primary natural food of carp spawn.

At first commercial lime is applied in the nursery ponds at the rate of 200 kg per hectare depending on the soil pH. Lime is applied all over the pond, after the removal of predatory fishes. Application of lime helps to improve soil and water quality, pond sanitation and the availability of nutrients for plankton development.

Most suitable manure to fertilize the nursery ponds is the commonly available cattle dung. About fifteen days prior to stocking of spawn, cattle dung is applied in the pond at the rate of 10,000 kg per hectare.

The application of cattle dung will lead to the growth of plankton, which reaches a peak production by about the tenth day.

Seven days after stocking the nursery with spawn, the second instalment of fertilization of the pond may be done with cattle dung at a lower dose ranging between 2,000 to 5,000 kg per hectare.

#### 12.4.5 Eradication of aquatic insects

A large number of aquatic insects and some of their larvae are present in the nursery and their incidence is more in a manured one. They breed and multiply rapidly during the monsoon season. Some of the aquatic insects prey upon the tender spawn and cause large scale destruction of the spawn. Hence eradication of insects earlier to stocking of carp spawn is essential to ensure the maximum survival of the spawn.

Among the aquatic insects, *Notonecta*, *Ranatra*, *Belostoma*, *Cybister*, *Nepa*, *Hydrometra*, *Lethocerus* are highly destructive to carp spawn.

A successful method to eradicate the predatory aquatic insects consists of spraying on water surface with an emulsion prepared by mixing any vegetable oil (coconut oil, mustard oil or any inexpensive vegetable oil) and cheap washing soap in the ratio 56:18 Kg per hectare. The emulsion should be heated for a short time and thoroughly mixed before spraying.

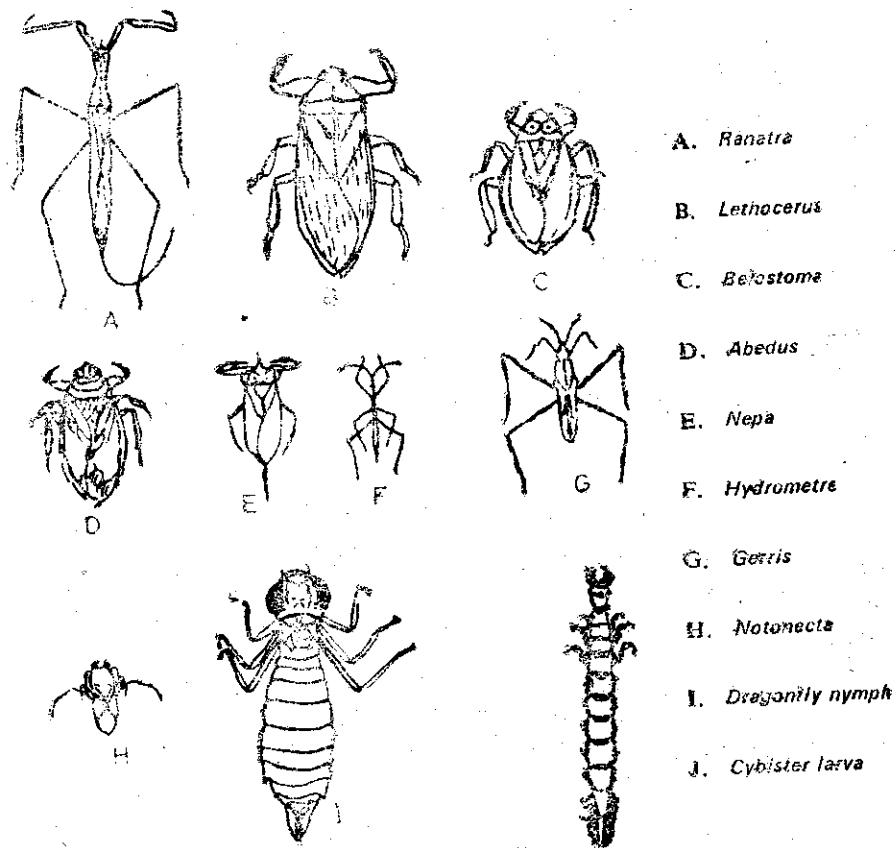

Fig.9.1. Aquatic insects

The thin oil film on the water surface prevents respiration of insects by closing their tracheal openings and thus causes their death.

#### 12.4.6 Stocking of spawn

Nursery ponds were used to be stocked with spawn at a density of 1 to 2 million per hectare.

In nursery ponds, generally, spawn of only one species is stocked. Stocking density of spawn depends on the plankton production in the ponds. Presence of minimum quantity of 1.5 to 2 ml of zooplankton in about 50 litres of pond water is an essential prerequisite to stock the pond with spawn.

Nursery ponds should be stocked either in the early morning hours or late in the afternoon to avoid mid-day heat. Spawn may be gently released in the pond after gradual acclimatization.

#### 12.4.7 Supplementary feeding

Survival and growth of spawn are influenced by the quality and quantity of food available in the pond. At high stocking densities mentioned earlier, zooplankton present in the pond is voraciously consumed by spawn within two or three days. In order to ensure healthy growth of spawn, and to supplement the natural food, it is necessary to provide artificial feed to the growing spawn.

Commonly used supplementary feed for *C. p.* spawn consists of finely powdered oil cake (groundnut, coconut oil cake) mixed in equal proportion (1:1 ratio) with good quality rice bran.

Supplementary feed mixture may be sifted through a fine meshed sieve to remove the husk, and to maintain uniform particle size. Quantity of the feed given is based on the weight of growing spawn. The following feeding schedule is found to be effective :

First to fifth day of stocking	:	5.6 kg. per day for one million spawn.
Sixth to twelfth day of spawning	:	11.2 kg per day for one million spawn
Thirteenth day after stocking	:	No feed
Fourteenth day after stocking	:	harvesting

To achieve optimum growth of spawn, growth promoting chemical cobalt chloride at the rate of 0.01 mg per day per fish may be provided along with the feed.

Supplementary feed should be broadcast over the pond water surface, daily once in the morning hours.

#### 12.4.8 Harvesting

In fifteen days period, carp spawn nursed by adopting the management measures stated above under normal pond conditions will grow to 25 to 30 mm size fry with survival above 60%. At this stage carp fry are ready for stocking in prepared rearing ponds.

It is not advisable to keep the fry in nursery ponds in such high density for a long period. Over crowding of fry leads to stunted growth and gradual increase of mortality. In order to prevent such an eventuality, harvesting of fry is to be carried out during the fifteenth to twentieth day of rearing.

Supplementary feeding is to be stopped a day before harvesting. Otherwise the fry with intestine gorged with food are liable to mortality. Harvesting of fry in nursery ponds should be carried out during morning hours.

In a season of three months, 3 to 4 crops of fry can be raised in the same nursery pond.

---

### 12.5 REARING POND MANAGEMENT

---

Rearing of carp fry (25 to 30 mm size) upto fingerling stage (100 to 150 mm size) is the aim of rearing pond management. Normally three months rearing period is sufficient for the fry to attain fingerling stage provided proper management measures are adopted.

Carp fry grown in the nursery pond are of relatively small in size and not fit enough for their direct transfer into stock ponds. In stock ponds bigger predatory fishes are likely to be present which may prey upon the fry. Hence it is desirable to grow the fry under proper protection to fingerling size so that their ability to resist predation will be improved. Specific feeding habits of the species will become evident at fingerling stage and they also develop capability to tolerate wide fluctuation in environmental conditions. Thus culture of fry in rearing pond is an essential intermediate phase in freshwater fish culture system.

A rectangular, dug out, earthen pond of 0.08 to 0.1 hectare (800 to 1000 Sq. metre) water area with 1.5 to 2.0 meters water depth is suitable as rearing pond. It provides increased food and space to the growing fry.

Prestocking management measures of rearing ponds such as the pond maintenance, removal of aquatic weeds, and eradication of predatory and unwanted fishes are similar to those described in nursery pond management. Since advanced fry are stocked, there is no need to control aquatic insects in rearing ponds.

### 12.5.1 Pond fertilization

Liming of the pond at a rate of 200 Kg per hectare prior to fertilization is an essential requirement. Fertilization of rearing pond is carried out by applying both organic and chemical fertilizers to augment production of phyto and zooplankton.

Organic manuring of the pond with cattle dung may be done at the rate of 10,000 Kg per hectare in four equal monthly instalments (2,500 Kg per hectare in each instalment). First instalment of organic manuring is to be carried out fifteen days earlier to stocking the pond with fry. Chemical fertilizers comprising urea at the rate of 140 Kg per hectare, and triple superphosphate at 60 Kg per hectare are applied in three to four equal monthly instalments. Organic manure and chemical fertilisers are to be applied alternating with each other at fortnightly interval to maintain sustained plankton production in the pond.

### 12.5.2 Stocking of fry

In rearing ponds, mixed culture of two or more species is conducted as the advanced fry of different species exhibit divergent feeding habits. Such a combination of different species ensures maximum utilization of natural food present in the pond.

Total stocking density of fry ranging from 0.2 to 0.3 million per hectare gives the best result in terms of survival and growth. Various combinations of major Indian carps : catla, rohu and mrigal, and exotic carps : silver carp, grass carp and common carp were tested. Three to four species combinations are found to be the most ideal. Combination of too many species results in excessive handling of fingerlings at the time of harvest which may be injurious causing death.

Prior to stocking the fry, toxicity of water should be tested by keeping a few fry for 24 hours in a hapa fixed in the pond. If there is no mortality, fry can be safely released in the pond. Stocking of the pond should be preferably done during morning or late afternoon hours, after getting the fry gradually acclimatized to pond conditions.

### 12.5.3 Supplementary feeding

Supplementary feed comprising rice bran and oil cake (groundnut or mustard) in 1:1 ratio by weight in powder form should be broadcast over the surface of pond water daily once during the morning hours.

Quantity of feed given is based on body weight of the growing fry. During the first month, quantity of supplementary feed per day is at the rate equivalent to the initial body weight of the fry stocked. Quantity of feed per day is doubled during the second month. It is three times the initial body weight of fry during the third month of rearing. When grass carp fry are stocked, they may be fed with small floating aquatic weeds like *Lemna*, *Wolffia*, and small cut pieces of *Hydrilla*.

### 12.5.4 Harvesting

Duration of rearing is based upon the size of fingerlings required. Rearing period is generally three months by the end of which fingerlings attain the desired size of 100 to 150 mm. Sometimes, the rearing period may be extended for six months depending on the growth, market demand and availability of stocking ponds etc. However, further extension of rearing period effects survival and growth apart from being un-economical.

Fingerlings of 100 mm and above are best suited for releasing in stock ponds. Therefore, fingerlings should be harvested after three months of rearing. Supplementary feeding may be stopped a day before harvesting. Harvesting should be done during the morning hours.

---

## 12.6 STOCK POND MANAGEMENT

---

Carp fingerlings are grown to marketable-size in stock ponds. Foremost objective of fish culture in stock ponds is production of maximum quantity of fish through the most economic management measures.

Guiding principles in the rational management of stock ponds are the culture of selected quick growing species, increasing the natural carrying capacity of the pond through fertilization and supplementary feeding; raising of compatible species having complementary feeding habits; optimum utilization of ecological niches in a pond by judicious stock manipulation; maintenance of water and soil quality, and fish health monitoring.

---

## 12.7 STOCK POND SELECTION AND MAINTENANCE

---

Stock ponds are larger unit areas of water. Size and shape of stock ponds may vary. But it is desirable that the stock pond is more than 0.5 hectare in area and rectangular in shape. The pond bottom should be even with gradual slope. Water depth should ordinarily be about 2 to 2.5 metres (minimum depth 1.5 metres). The main criteria to be kept in mind while selecting the pond site are the water retentive capacity of the soil and an assured supply of water.

Conservation of pond embankments is a general maintenance measure. If cracks are noticed they must be repaired at once. Excessive aquatic vegetation growing along the embankment margin is to be controlled. Trees planted on the embankment should not obstruct sun light and air movement over the pond. Inlet and outlet facilities of the pond are to be cleaned regularly and well protected.

Restoration of pond bottom is essential to improve the physical, chemical and biological condition of the soil. Drying up of the pond increases mineralization, removes obnoxious gases accumulated in mud, reduces and destroys the aquatic weeds and undesirable organisms and ameliorates the pond sanitation.

Ploughing of the pond bottom improves soil condition but it should not be deep as it buries the fertile top layer and brings up the deep sterile layer to the surface. Ploughing with 180° turnover of soil destroys the aquatic weeds. Silting up of the pond occurs much faster if the pond is shallow. Desilting of pond is essential to maintain productivity.

### 12.7.1 Control of aquatic Weeds

Aquatic weeds are defined as those undesirable vegetation which reproduce and grow in water and if left unchecked may choke the water body causing a serious menace to fish culture.

Infestation of aquatic weeds (*Pistia*, *Eichhornia*, *Nymphaea*, *Hydrilla*, *Typha*, *Ipomea* etc) reduce the fish production in ponds just as the weeds in agricultural fields decrease the yield of cultivated crops.

Control of aquatic weed infestation could be done by manual, mechanical, chemical and biological methods.

Manual clearing of weeds is the most common practice where labour is cheap. It is a simple, traditional method and immediately effective in smaller water bodies. It is carried out by hand picking, uprooting and cutting with sickles. However, weeds removed by this physical method, regenerate fast and in deeper water bodies it is difficult to clear all the weeds.

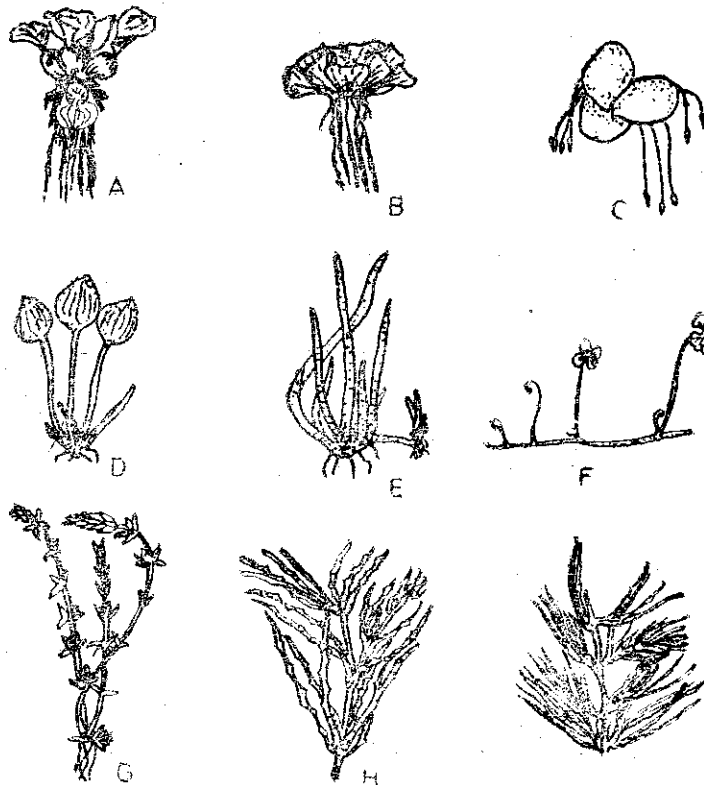

Fig. 9.2  
Aquatic weeds

- A. *Eichhornia*
- B. *Pistia*
- C. *Lemna*
- D. *Ottilia*
- E. *Vallisneria*
- F. *Marcellia*
- G. *Hydrilla*
- H. *Najas*
- I. *Ceratophyllum*

Fig.9.2. Aquatic weeds

Mechanical methods of weed clearing were tried only on a limited scale in India. Power winches, weed cutting launches were tested in large water bodies. These methods are expensive.

Chemical methods of aquatic weed control if properly chosen and used, proved to be more effective reliable and convenient.

Water hyacinth (*Eichhornia crassipes*) is the most noxious floating weed which infected the water bodies extensively in India. This weed is most susceptible to the chemical 2,4-D (2, 4-dichlorophenoxy acetic acid).

Algal blooms and mats can be effectively cleared by herbicides Simazine at the rate of 0.5 to 1 ppm, and Diuron at 0.1 to 0.3 ppm.

The biological method of weed control is the best, when the controlling agent itself is a fish. Certain types of weeds can be controlled by means of selected varieties of herbivorous fishes. In this method, the weed-eating fish directly converts the weeds into fish flesh. Important herbivorous fishes are *Ctenopharyngodon idella*, *Tilapia mossambica*, *Osphronemus goramy*. Common carp (*Cyprinus carpio*) uproots the vegetation. Tilapia and gourami control the filamentous alga. Grass carp (*C. idella*) is the most efficient fish which eats a wide variety of weeds.

In addition to the fish, ducks can be employed for controlling aquatic vegetation and their manure can be recycled to fertilize the ponds. It is possible to control the submerged weeds by creating high turbidity in pond water which obstructs the penetration of sunlight. Once aquatic weeds are cleared, follow-up maintenance is necessary to prevent the regeneration of weeds.

### 12.7.2 Eradication of unwanted fishes

Mahua oil cake applied at the rate of 250 ppm (2,500Kg per hectare metre) eradicates all the fishes and also serves as a fertilizer. Details of the fish toxicants were discussed in nursery pond management.

### 12.7.3 Liming of the ponds

Application of lime has varied and favourable action on the factors which control the production and fish health. Liming the pond has an anti-parasitic action. It destroys fish parasites in the water. Liming decreases the acidic nature of soil and water, and improves the pH and alkalinity to more desirable level. Due to application of lime, biological decalcification is avoided, and presence of sufficient calcium neutralizes the harmful action of magnesium, sodium and potassium salts. Liming improves release of the nutrients, quickens the mineralization of organic matter thus improving the efficacy of fertilizers and reduces the danger of dissolved oxygen deficiency. Presence of lime helps in nitrification of ammonium compounds into nitrites and nitrates. Liming precipitates excessive organic matter suspended in the water, and it reduces water turbidity.

Powdered limestone ( $\text{CaCO}_3$ ), quicklime ( $\text{CaO}$ ) slaked lime or caustic lime can be used for liming the pond. Lime is to be applied all over the pond surface prior to fertilization.

### 12.7.4 Pond fertilization

The production of plankton depends on the quantity of nutritive substances available in the presence of light and temperature. Nitrogen, phosphorous and potassium are the primary nutrients. The quantity of primary nutrients present in the ponds varies from pond to pond and in general they are found in minimum quantities.

The nature of pond bottom determines the productivity of pond. The nutritive substances in fertilizers are absorbed by the mud which liberates them gradually into water medium. Phytoplankton has the capacity to utilize the nutrients directly, and grazing on the phytoplankton has the capacity to utilize the nutrients directly, and grazing on the phytoplankton, zooplankton is developed.

Various organic manures and chemical (inorganic) fertilizers are applied in ponds. Organic manures commonly used in fish culture are the cattle dung, pig and poultry manures, composts, green manure and sewage.

### 12.7.5 Chemical fertilizers

Chemical fertilizers are inorganic materials which are rather of concentrated nature. Commonly used inorganic fertilizers in fish culture in the country are urea, ammonium sulphate, calcium ammonium nitrate, single and triple super phosphates and muriate of potash.

All the essential nutrients are supplied in the form of either organic manures, individual chemical fertilizers or in a combination of organic manures and chemical fertilizers in suitable proportions and doses. Fertilizer doses are fixed on the basis of nutrients status of the soil. Selection of inorganic fertilizers is governed by the reaction of the soil.

Raw cattle dung is applied at high doses ranging between 10,000 to 25,000 Kg per hectare per year in suitable instalments. Nitrogen, phosphorus and potassium mixed fertilizers (N-P-K 6-8-4) at the rate of 500 Kg per hectare per year in equal monthly instalments have yielded good results. Mixture of ammonium sulphate, single superphosphate and calcium ammonium nitrate in 11:5:1 ratio at 1,000 to 1,500 Kg per hectare per year with suitable variations depending on water and soil quality were also adopted.

### 12.7.6 Stocking

Ponds are generally stocked with fingerlings of sizes ranging from 100 to 150 mm. The size range can be smaller, 75 to 100 mm., provided the ponds are free from predators. It has to be ensured that healthy fingerlings, free from parasites and diseases are to be stocked.

Multispecies fish culture is a rule in stock ponds. Selection of fish species having desirable qualities is an important biological means for increasing fish production. Since fishes with shortest food chain give the highest production, herbivorous, planktophagous, omnivorous and detritous feeding fishes are preferred for cultivation in stock ponds. Much preferred species that are cultured in India are the major Indian carp : catla (*Catla catla*), rohu (*Labeo rohita*), mrigal (*Hypophthalmichthys molitrix*), grass carp (*Ctenopharyngodon idella*) and common carp (*Cyprinus carpio*).

Proper combination of fish species in suitable numbers minimise the inter and intra-specific competitions allowing proper growth of all species. Fish species and combination are also depend on the public demand, marketable-size preferred by the consumers, and the length of culture period.

### 12.7.7 Supplementary feeding

In India use of supplementary feeding in stock ponds is a recent origin. It is one of the principal methods of increasing fish production. It allows higher stocking density and helps in efficient utilization of natural food, unconsumed supplementary food in turn serves as fertilizer. It helps to grow fish to the desired marketable weight.

Supplementary feeds given to the cultivated fishes which are of plant origin are rice bran, wheat bran, soya bean, maize, oil cakes, oats, roots, leaves and grasses, tubers. Supplementary feeds of animal origin are the dried fishes, fresh and marine fishes, fish meal, minced meat, blood meal, silk worm pupae, crabs, snails etc. Minerals and vitamins are also added.

Preparation of supplementary feed distribution are the entire quantity of feed must be eaten by the fishes before the next distribution. Feed is to be distributed in the morning hours, and it is not to be broadcast over the entire water surface of pond. Feed may be placed in marked spots, in the traps or in perforated bags. Feeding spots should be checked periodically and changed so that no decay of feed occurs. Supplementary feeding should be stopped temporarily whenever algal blooms appear in the ponds.

### 12.7.8 Health protection

With the adoption of intensive farming techniques including enhanced stocking densities, there is every likelihood of increased incidence of health hazards to the cultivated fishes. Since large, scale mortality is not of common occurrence in carp ponds, it is believed that disease prevalence is generally low. However, recently it is observed that stress factors and rough handling are causing columnar disease in cultivated carps, which can be prevented by using antibiotics (penicillin + streptomycin).

In addition to the application of lime which improves pond sanitation, common prophylactic treatments such as the dip treatment of fish with potassium permanganate (20ppm), or formalin (250 ppm) controls pathogenic infection. A part from adopting prophylactic treatment it is essential to check the health conditions of cultivated fishes as frequently as possible, will help in taking up timely preventive.

### 12.7.9 Harvesting

Complete harvesting every year is an ideal proposition. However, partial harvesting is also done in the stock ponds. It is feasible to raise two crops of marketable fish in an year, and it

may be more economical as this system can get the returns of investment quickly. However this system depends on the availability of fingerlings round the year.

Harvesting of the fishes are effectively done by repeated drag netting. Complete harvesting may be carried out by draining the ponds. In larger water gill nets and cast nets can be used for harvesting. However, harvesting in larger and deeper ponds which cannot be drained poses serious problems, while surface feeders are easily caught with a drag net, bottom wellers usually escape. It was observed that the conventional drag net could collect 90 per cent of surface and column feeders, where as only 20 to 40 percent of bottom dwelling fishes are caught with the same number of hauls. Drag net with pockets is developed which is more effective in catching the bottom dwelling fishes.

Choosing the right time for harvesting the fish crop ensures proper financial return. Therefore, harvesting programme is to be regulated as per the market demand.

Carp fingerlings normally attain table-size weighing above one Kg within one year of rearing. By adopting scientific management techniques, fish production of about 4,000 Kg per hectare per year with major Indian carps, about 2,9000 Kg per hectare per year with exotic carps alone, and over 10,000 Kg per hectare per year by combined culture of Indian and exotic carps were achieved in stock ponds with average survival over 80 per cent.

### Check Your Progress

1. Predatory fishes which cause extensive damage to carps are \_\_\_\_\_, \_\_\_\_\_, \_\_\_\_\_ etc.,

---

## 12.8. SUMMARY

Various aspects of pond management are described here. The Scientific management of form ponds are described here which is very essential for the proper development of fish culture methods. It also dealt with pre-stocking and stocking techniques of fishes, maintenance of stocking ponds etc.

The eradication of predatory and unwanted fishes, harmful aquatic insects etc. is also described in detail.

Even eradication of unwanted aquatic weeds etc. is described here.

---

## 12.9. CHECK YOUR PROGRESS - MODEL ANSWERS

1. *Channa, Anabas, Wallago, Clarias.*

---

## 12.10 MODEL EXAMINATION QUESTIONS

I. Answer the following in about 30 lines.

1. Explain the pre-stocking management measures in nursery ponds.
2. Write about the supplementary feeding in nursery ponds.
3. Describe the post-stocking management practices in rearing ponds.
4. Write about the control of aquatic weeds in stock ponds.
5. Give an account of fertilization in stock ponds.

**II. Answer the following in about 10 lines.**

1. Broad groups of scientific management techniques of farm ponds
2. Stocking of fry in rearing ponds
3. Stock pond maintenance
4. Liming of the pond
5. Carrying capacity of the pond

---

**12.11 GLOSSARY**

---

Acrid	:	Bitter
Acrobic	:	Requiring free oxygen to maintain life processes.
Algal bloom	:	A sudden increase in the abundance of planktonic algae, especially at a near the water surface. A condition when water looks green because of the abundance of planktonic algae.
Algicide	:	Algae destroying agent.
Alkalinity	:	Number of hydroxyl ions released in water, giving a pH higher than 7.
Allochthonous	:	Due to outside factors.
Anaerobic	:	Not requiring free oxygen to carry on respiration.
Anion	:	Electrically negatively charged ions.
Antibodies	:	Protein molecules in the blood which fight the bacteria.
Aperthy	:	Carelessness ; Dull
Autochthonous	:	Due to within factors.
Back waters	:	Settlement of sea water in the lowlying areas along the coast areas ; fed by tides or seepage from the Sea. Generally the salinity is very high.
Berm	:	A narrow path made between the base and the top of embankment.
Biosmass	:	Plant and animal matter existing in a water body expressed quantitatively.
Brackish water	:	Mixture of sea water and fresh water with a salinity of less than 30 parts per thousand.
Brood fish	:	Sexually manured fish, especially for breeding in fish farms.
Carapace	:	A continuous shield like enoskeletal covering of the cephalothorax.
Carrying capacity	:	The maximum quantity of that any particular water body can support over a long period.
Cation	:	Electrically positively charged ion.
Debility	:	Weakness
Decalci	:	A process in which due to the uptake of carbon dioxide (by plants) the equilibrium between calcium bicarbonate and the pressure of carbon dioxide in water is destroyed, resulting in the precipitation of calcium carbonate.

<b>Decarboxylation</b>	:	Degradation of carboxylic acid. By this process carbondioxide is eliminated to form new compounds.
<b>Demersal</b>	:	On the bottom; also applied to fish eggs which sink to the bottom where they hatch.
<b>Diurnal</b>	:	Pertaining to day.
<b>Draught</b>	:	1. Pulling in of a net for fish, the fish caught in it. 2. Depth of water needed to float a boat.
<b>Drip</b>	:	Flow of tissue fluids from the frozen fish muscle during freezing.
<b>Dyke</b>	:	Long ridge or embankment.
<b>Ecological niche</b>	:	A particular role (or set of relationships) of organism in an ecosystem which may be filled by different species in different geographical areas. Ex: Zooplanktophagic Catla catla in India and Aristichthys nocilis in China.
<b>Estuarine environment</b>	:	The region where the river enters into the sea, with tidal fluctuations of salinity.
<b>Entroplication</b>	:	The complete sequence of changes whereby deep clean water body of low productivity gradually becomes water body of low productivity gradually becomes shallow ever and more productive, eventually filling up completely and becoming dryland.
<b>Exopodite</b>	:	Outer basal portion of portion of prawn appendage.
<b>Exotic</b>	:	Introduced from abroad.
<b>Facultative parasite</b>	:	Parasitizing under certain circumstances only.
<b>Fecundity</b>	:	Breeding capacity of a fish or prawn at a given time (i.e. no. of mature eggs present with ovary at a given time).
<b>Ferruginous</b>	:	Contaminated with iron.
<b>Fillet</b>	:	Strips of flesh cut parallel to the backbone of the fish.
<b>Fish kill</b>	:	Massive, rapid death of fish due to several reasons such as oxygen defect, inflow of toxicants, infections diseases etc.
<b>Fish seed</b>	:	Fish juveniles including the hatchings, fry and fingerling stages.
<b>Fry</b>	:	Advanced post larval stage of fish before becoming adults.
<b>Glycerides</b>	:	Esters of fatty acids and glycerol.
<b>Gunwale</b>	:	Upper edge of a boat's side.
<b>Hatchling</b>	:	The early larva that emerges out of the hatching of the fertilized egg.
<b>Herbicide</b>	:	A chemical or other product (uses any poisonous) used for destroying weeds.
<b>Herbivorous fish</b>	:	Fish feeding on plants.
<b>Hull</b>	:	The frame of a boat.
<b>Impoundment</b>	:	An artificial body of water. Reservoir.
<b>Infections diseases</b>	:	Diseases caused by infection.
<b>Interspecific</b>	:	Referring to event or relationships which occur between individuals of the different species.

Intraspecific	:	Referring to event or relationships which occur between individuals of the same species.
Keel	:	The principal supporting timber located at the lower portion of a boat.
Lab lab	:	Biological complex consisting of decayed green and blue green algae, protozoa, bacteria and debris.
Leaching	:	Washing out
Lestous	:	Wounds
Nauplius	:	First is a series of larval phases in crustacea.
Osseous	:	Bony
Parameters	:	Factors; aspects affecting
Perennial	:	Throughout the year.
Pereopods	:	The appendages of a prawn attached to the thoracic region.
PH	:	Hydrogen ion concentration.
Phagocytize	:	Absorb; eat
Phytoplankton	:	Free floating microplants with chlorophyll synthesizing stences in the presence of sunlight.
Pleopods	:	The abdominal segments of a prawn on the ventral side.
Polymerization	:	A chemical reaction which is capable of proceeding indefinitely either by condensation or addition of small molecules and give a compound of infinite molecular weight.
Prophylactic	:	Precautionary
Raft	:	A fleet of wooden legs.
Ramming	:	Beat down the soil with wooden or iron block with face.
Rancidity	:	Unpleasant odour.
Recruitment	:	Addition of new fish to the vulnerable population by growth from among smaller size categories.
Relative condition	:	Observed weight of fish or prawn divided by calculated weight, obtained from length. Weight equation.
Saponification	:	Hydrolysis by an alkali.
Seepage	:	Leakage of water through porous sand or mud.
Siltation	:	Deposition of finally divided sediments, consisting of rock and clay particles.
Skimmed	:	To clear from any substance floating on the top of a liquid.
Sluice	:	A structure for impounding the water of a canal, neck etc., provided with a sluice gate by which the volume of water is regulated.
Stacking	:	Piled up in a regular form for keeping and often hatched.
Stakes	:	Strong pointed sticks driven into the ground as a post or support.
Stocking rate	:	Number of fish released for unit area.
Stressors	:	Adverse environmental condition.
Telson	:	The posterior most triangular part of the abdomen in a prawn.

<b>Toxicity</b>	:	<b>Lethal effect.</b>
<b>Turbidity</b>	:	<b>Water which is not clear and into which light cannot pass through.</b>
<b>Warpsing</b>	:	<b>Usage of long ropes for fishing.</b>
<b>Weir</b>	:	<b>Wall or similar structure built across a river to control the flow of water.</b>
<b>Zooplankton</b>	:	<b>Free floating microanimals, including small adult animals and larval form of some of the adult aquatic animals.</b>

BRAOU

---

# UNIT - 13 FRESHWATER AQUACULTURE SYSTEMS

---

## Contents

- 13.1. Objectives
- 13.2. Introduction
- 13.3. Composite Fish culture System
- 13.4. Integrated Fish farming and Animal Husbandry systems
- 13.5. Fish cum Duck Culture
- 13.6. Fish cum Poultry Culture
- 13.7. Fish cum Pig Culture
- 13.8. Fish Culture cum Cattle Management
- 13.9. Fish Culture in Paddy Fields
- 13.10. Fresh Water Prawn Culture
- 13.11. Air Breathing fish Culture
- 13.12. Techniques of Seed Production
- 13.13. Culture of air-breathing Fishes
- 13.14. Summary
- 13.15. Check Your Progress - Model Answers
- 13.16. Model Examination Questions

---

## 13.1 OBJECTIVES

---

This unit deals with composite fish culture technology of Indian major carps and exotic carps, integrated fish-animal husbandry-paddy culture systems, freshwater prawn farming, and culture of air-breathing fishes. Scientific management measures, and production aspects of the systems are described in detail.

---

## 13.2 INTRODUCTION

---

The basic principle of composite fish culture system is the stocking of various fast-growing, compatible species of fish with complementary feeding habits to utilize efficiently the natural food present at different ecological niches in the pond for maximising fish production. Composite fish culture technology in brief involves the eradication of aquatic weeds and predatory fishes, liming : application of fertilizers on the basis of pond soil and water quality, stocking with 100 mm size fingerlings of Indian major carps-catla, rohu, mrigal, exotic carps,silver carp, grass carp and common carp in judicious combination and density; regular supplementary feeding and harvesting of fish at a suitable time. Composite fish culture system is conducted by adopting three types of combinations viz., culture of Indian major carps alone, culture of exotic carps alone, and culture of Indian and exotic carps together. Fish production ranging between 3,000 to 6,000 Kg. per hectare per year is obtained normally through composite fish culture system.

Development of intensive pond management measures have led to increase the fish yield further. Integrated fish and animal husbandry systems evolved recently are the fish-cum-duck culture, fish-cum-poultry culture, fish-cum-pig culture, utilization of cattle farm yard wastes and recycling of biogas plant slurry for fish production. Advantages of the combined culture systems, number of birds/animals, quantity of manure required and fish production potentiality of the recycling systems are described. Fish culture in paddy fields is an important integrated fish cum agriculture system. Essential requirements of paddy fields to conduct fish culture, characteristic features suitable for culture in rice fields, constraints to culture fish in paddy fields due to recent agrarian practices, and improved fish-paddy farming methodologies are discussed. Freshwater prawn culture is a recent practice. Giant freshwater prawn *Macrobrachium rosenbergii* and Indian riverine prawn *M. malcolmsonii* are the two most favoured species for farming purposes in India. Breeding, hatchery management, seed production, culture systems and production potentialities of the freshwater prawns are presented. Commercially important air-breathing fishes of India are the murrels, climbing perch, singhi and magur. Techniques of their seed production and culture systems are described.

---

### 13.3 COMPOSITE FISH CULTURE SYSTEM

---

Freshwater pond fish culture has a long history in India and is traditionally confined to the states of region. In the traditional system, ponds are usually stocked with indigenous major carps catla (*Catla catla*), rohu (*Labeo rohita*), mrigal (*Cirrhinus mrigala*) either in spawn, fry or early fingerling stage at high stocking densities. Traditional fish culture is generally depended on the natural productivity of water bodies, and the methods of management followed are empirical. Supplementary feeding is unknown. Fishes are often parasitized. Survival is exceedingly low and large quantity of fish seed is wasted. Annual fish production in traditional farming has been estimated to vary between 300 to 1000 Kg. per hectare with an average of about 600 Kg per hectare.

Composite fish culture system practiced in India is a synonym of multispecies fish culture followed in China, polyculture in Europe and USSR, and mixed fish culture in Mediterranean area. Though the concept is the same, different fish species are cultivated in these countries. In India, both indigenous major carps and exotic carps are stocked in various combinations.

Basic principle of composite fish culture system is the stocking of various fast-growing, non-predatory, compatible fish species with different habits to achieve optimum utilization of natural food present at different ecological niches in the pond for maximising fish production.

Other guiding principles of composite fish culture system are stocking the pond with efficient fish species which are complementary to each other in judicious combination and density to reduce competition and fully utilization of the space, increasing the carrying capacity of pond through fertilization and supplementary feeding and stock manipulation by intermittent harvesting and replenishment for increased production.

Composite fish culture technology involves pond maintenance and water management, control of aquatic weeds, eradication of unwanted fishes, fertilisation on the basis of nutrient status of pond soil and water, stocking with different carp species, supplementary feeding and harvesting of fish at a suitable time, depending on the growth performance of each species.

Water level management in ponds is a crucial factor in composite fish culture system. Studies have indicated that in ponds with good water level (above one metre) fish production ranged from 4,123 to 10,302 Kg per hectare.

Composite fish culture ponds are prepared by removing the aquatic weeds and unwanted fishes. Complete eradication of predatory and other unwanted fishes is carried out by the application of vegetable fish toxicant mahua oilcake at 2,000 to 2,500 Kg per hectare metre (200 to 250 ppm). In order to ameliorate the pond soil and water quality, lime is applied at 200 to

1,000 Kg per hectare on the basis of soil pH. Periodical application of lime in composite fish culture ponds led to considerable improvement of the soil and water quality and pond sanitation.

A necessary prerequisite in composite fish culture system is the fertilization of ponds with organic manures and chemical fertilizers. Most commonly used organic manure is the cattle dung. Adequate quantity of cattle dung is adjusted depending on the status of organic carbon in pond soil. If organic carbon level in the soil is low (below 1 per cent) a total quantity of 25 to 30 tonnes of cattle dung is required and if it is above 2 percent about 10 to 15 tonnes of cattle dung is to be applied.

The first instalment of cattle dung should be 1/6th of the total quantity and the remaining is to be applied in 10 equal monthly instalments. The first instalment may be broadcast in the pond about 15 days prior to stocking with fingerlings.

Chemical fertilizers such as urea, ammonium sulphate, single or triple superphosphate and muriate of potash are applied in the ponds. The combination of N : P : K - 18 : 8 : 4 at the rate of 500 to 750 Kg per hectare per year is generally recommended.

Chemical fertilizers are applied in the pond in equal monthly instalments alternating with organic manure at 15 days interval. Fertilization is to be stopped temporarily whenever algal blooms persisted in the pond during summer months.

Fish species found to be most efficient in the composite fish culture system are the Indian major carps, catla, rohu, mrigal, the Chinese silver carp, grass carp and Indonesian strain of common carp. Feeding habits of these species are as follows:

Catla and silver carp are both surface feeders, but while the former feeds mainly on zooplankton, the latter feeds predominantly on phytoplankton. Rohu is largely a column feeder and its diet comprises a wide variety of algal forms as well as decaying macrovegetation. Grass carp is a voracious feeder on certain types of aquatic macrovegetation and terrestrial grasses which are commonly used as fodder for cattle. Mrigal is a bottom dweller subsisting mainly on semi-decayed vegetable matter and detritus. Common carp is an omnivorous scavenger generally feeding on the bottom or at the pond margins. Fingerlings of 100 mm size are stocked in the composite fish culture system.

In composite fish culture system, carps are stocked generally in three types of combinations viz., culture of Indian major carps, catla, rohu and mrigal, culture of exotic carps, silver carp, grass carp and common carp, and culture of Indian major carps exotic carps together.

Culture of Indian major carps alone is an age-old practice in the country and catla, rohu and mrigal are reported to be stocked commonly in the ratio 3:3:4, 4:3:3 or 3:4:3 respectively at a total stocking density 3,000 to 3,500 fingerlings per hectare resulted in obtaining improved fish yield. Composite culture of exotic carps viz., silver carp, carp, grass carp and common carp in the ratios 4:2:3 or 3:1:2 respectively at total stocking density of 3,700 to 5,000 fingerlings per hectare indicated density of 3,700 to 5,000 fingerlings per hectare indicated higher production potentiality of exotic carps than the Indian major carps.

Supplementary feeding is an important management measure in the composite fish culture system to maximise fish production. Ricebran and oil cake of either groundnut or mustard constituted the supplementary feed, which is given daily to the fishes in 1:1 ratio by weight and at the rate of 1 to 2 percent body weight of the standing crop. The quantity and frequency of supplementary feed is altered according to the fish requirements, their growth and water condition. Aquatic weed *Hydrilla*, *Chara*, *Lema*, *Ceratophyllum* and terrestrial fodder grasses such as lucerne, napier and para grasses are fed to grass carp daily according to the consumption by the fishes. Keeping the weeds and grasses on bamboo platforms fixed in the pond improved the feeding rate of grass carp.

Composite fish culture of Indian major carps alone has yielded fish production at the rate of 2,193 to 2,975 Kg per hectare per year with a maximum of 5,564 Kg per hectare per 16 months.

By culturing exotic carps alone fish production ranging from 2,909 to 3,287 Kg per hectare per year was obtained.

Composite fish culture system of Indian and exotic carps together has resulted in achieving annual fish yield from 2,900 to 4,200 Kg per hectare, even in the earliest year of experimentation. Adaptation of intensive pond management measures have led to the gradual increase in fish yield from 6,053 to 9,389 Kg per hectare per year.

Utilization of carp fry as stocking material at high densities of 8,000 to 10,000 numbers per hectare, record fish production rates to 20,194 to 10,677 Kg per hectare per year were achieved.

#### Annual costs and returns of a traditional Fish Culture Operation

Costs:	Rs.
Pond rental	2,000
Pond preparation	1,000
Seed (7,500 - 1,0000 fry)	3,000
Harvesting charges	600
Total Cost	6,600
<b>Returns :</b>	
Yield at 1,000 Kg per hectare	
Gross income at Rs. 9 per Kg	9,000
Gross farm business income	2,400
Ratio of business income to Gross income	26.6%

Composite fish culture technology in field demonstration trails in farmer's ponds has yielded production levels ranging from 4,000 to 6,000 Kg per hectare of culturable water area. Supplementary feed is the most expensive input in composite fish culture system. It exceeds 60 % of the total cost incurred in production. Although the total operational costs are considerably higher in the composite culture system, profits are also outstanding. Because productivity is high, the unit cost of production is relatively low about Rs. 4 to 5 per Kg of fish against the prevailing farmgate price of fish about Rs. 9 to 12.

### 13.4 INTEGRATED FISH FARMING AND ANIMAL HUSBANDRY SYSTEMS

Integrated systems are ideal for location in rural areas and easier for the farmers to understand and operate. Combined culture systems are energy-efficient food production systems and by recycling organic wastes, valuable resource in the form of animal protein can be recovered and its production is enhanced from the unit area. Recycling systems control the pollution caused by improper disposal of animal wastes. Adaption of combined culture systems promotes integrated rural development, provides year round employment and income for the family.

### 13.5 FISH CUM DUCK CULTURE

The second most important kind of poultry raised in India is the ducks. Access to the aquatic environment is essential for the health and growth of ducks. Rearing of ducks in areas of proximity to the water resources has been traditionally practiced since centuries in India, China, and Central European countries, but their beneficial effect on fish production was not known till recently.

Ducks searching for food in the pond consume aquatic organisms such as molluscs, frogs, tadpoles, mosquito and other insect larvae and aquatic weeds which are not generally eaten by

fish. This promotes profitable utilization of natural food produced in the pond and also eliminates organisms likely to be harmful to the cultivated fish. Constant movement of ducks causes water aeration. Regular disturbance of pond substrate by duck while feeding helps nutrient release from bottom soil thus improving the nutrient content of the water medium.

Duck culture on fish ponds is in synchronization with the ecological concept of composite fish culture system. Ducks occupying the unutilized pond water surface, act as "manurial machines" fertilizing the whole pond areas continuously. Release of manure all over the pond by ducks saves expenditure on labour.

Ducks eat the smaller fishes. Generally speaking ducks must be kept off nursery ponds and rearing ponds where the fish are smaller than 4 g. However, fingerlings above 5 to 10 g can easily escape from the ducks. Because of the fish feeding habit of ducks, the population of unwanted weed fishes in stock ponds can be effectively controlled.

In this system ducks are benefited by the availability of protein food. They are also provided with clean and healthy habitat. Pond reared ducks are generally free from parasites and diseases.

Ducklings of the 2 week age group can be released in the fish ponds after gradual adaptation to life on the water. Ducks commence egg laying in about 6 to 7 months of age. They are allowed free movement over the pond surface during day time. In the night time, they are housed in simple protective structures of split bamboo, constructed on pond embankments. Floating housing structures have also been tried. Housing structures should be well ventilated, clean and dry as far as possible. It has been calculated that one duck produces about 6 Kg of droppings during 30 to 40 days on a pond. The major beneficial effect of fish cum duck culture is derived from the fertilizing effect of duck droppings. Duck manure increases production of natural fish food organisms and some fishes will also feed directly on the duck droppings.

In Andhra Pradesh, near Kolleru lake area there are well developed duck rearing, egg and meat marketing facilities. This area is most suitable for adopting integrated fish cum duck farming as extensive fish culture in tanks also exists locally.

---

### 13.6 FISH CUM POULTRY CULTURE

---

Utilization of poultry manure in fish culture is a recent practice. Two types of methods are adopted in recycling the poultry manure for fish farming. The first method is to collect the manure from poultry farms located somewhere else and then broadcast the manure in ponds in regular instalments. Another system is constructing the poultry housing structure partially covering the fish tank and directly recycling the droppings for fish culture. In the first method manurial application and quantity is controlled and it is being increasingly adopted these days at present. In the second method of direct recycling, excess manure while decomposing may cause oxygen depletion and consequent fish kills in the pond.

It has been estimated that 40 laying birds yield about one tonne of manure in an year. It has also been suggested that 500 hens having total live weight of 450 Kg may yield total wet manure of about 25 kg per day.

Poultry manure in fresh condition contains 1.0 to 1.8 per cent nitrogen, 1.4 to 1.8 percent phosphorous ( $P_2O_5$ ), 0.8 to 0.9 percent potash ( $K_2O$ ), other trace elements and valuable organic matter.

Manuring the pond with poultry droppings is found to produce dense population of both phyto and zooplankton dominated by rotifers. Peak plankton production is observed on 12 the day after manure application. Poultry manure is a complete fertilizer which characteristics of both organic and chemical fertilizers.

---

## 13.7 FISH CUM PIG CULTURE

---

The systems of fish cum pig farming developed recently in India has opened up a new horizon of increased animal protein production at low cost and it proved to be an efficient means of animal waste utilization, saving chemical fertilizers and supplementary feeds. Pig manure contains 3.7 percent nitrogen, 3.3% phosphorus ( $P_2O_5$ ) and 0.4 percent potash ( $K_2O$ ).

It is estimated that each pig voids about 550 to 600 Kg manure in a year, and therefore about 35 to 40 pigs would be sufficient for one hectare of water area.

In Kolleru lake area of Andhra Pradesh, fish farmers are utilizing pig manure collected from government pig farms for carp culture in tanks. Pig manure applied at the rate of 5,000 Kg to 10,000 Kg per hectare per year in instalments has considerably improved the fish production from tanks.

Combined fish-pig farming as a special significance as it can improve the socio-economic status of tribal community who traditionally rear pigs.

---

## 13.8 FISH CULTURE CUM CATTLE MANAGEMENT

---

### *Utilisation of cattle dung in fish culture*

Application of cattle dung to rear fish has been a traditional practice in India and is still being continued as a major source of nutrients for aquaculture. For fish seed nursery ponds, raw cattle dung is generally considered to be the best.

A short term experiment, by manuring the pond with raw cattle dung alone, without any fertilizers and supplementary feed resulted in fish production 535 Kg per hectare per 90 days. Long term experiments yielded fish production corresponding to 1,350 to 1,986 Kg per hectare in 11 to 12 months.

### *Utilisation of cattle farmyard Wastes in fish culture*

Cattle farm yard wastes comprising the 'solid wastes' and 'liquid wastes' is perhaps the most valuable and extensively available organic matter in the rural sector of India. Though its crop increasing value was recognised from time immemorial, fish production potentiality of the cattle yard wastes has not been properly evaluated. Dry farmyard manure consists of 0.4 to 1.5 percent nitrogen, 0.3 to 0.9 percent phosphorous ( $P_2O_5$ ) and 0.3 to 1.9 percent potash ( $K_2O$ ). Cattle urine contains 0.9 to 1.2 percent nitrogen and 0.5 to 1.2 percent potash. Phosphorous is available only in traces. Initial experiments indicated that the carp production corresponding to 3,911 Kg per hectare per 11 months can be obtained by manuring the pond with cattle farmyard wastes only.

### *Utilisation of biogas plant slurry in fish culture*

Biogas plant which is also commonly known as gobar gas plant is a device for conversion of fermentable organic matter, particularly cattle dung into combustible gas and fully matured organic manure. This is achieved by subjecting the organic material to anaerobic fermentation. The gobar gas plant, in addition to cattle dung can also digest night soil, poultry or piggery droppings and other such fermentable materials.

Biogas plant is a composite unit of a digester and gas holder. Gas holder floats on the top of digester, where in gas is collected. In gobar gas plant the whole system is based on continuous operation i.e. the organic manure to be fermented is fed in semifluid form at one end and the fermented spent slurry is extracted at the other end periodically, without disturbing the whole

system. Slurry of the manure is not only rich in its nutrients, but is also innocuous and odourless, free from the flies and other sources of infection.

There is a growing interest and emphasis on the fertilizer value of the digested slurry, and it has even been suggested that biogas plant slurry is rich in humus and contains the nutrients in available form. Slurry has a high rate of nitrogen and Phosphorus release. Slurry creates less acidic condition and its biological demand of oxygen is less than that of cattle dung. Slurry application improves the soil structure. In water medium it enhances zooplankton production.

Preliminary experiment conducted by draining the slurry everyday from a gobar gas plant into a fish pond of 0.15 hectare area, and stocked with fry of catla, rohu, mrigal, silver carp, grass carp and common carp at a density of 7,500 numbers per hectare, resulted in total fish crop of 762 Kg from the pond in 11 months culture period. This experiment indicates the high production potentiality of the system.

It was observed that fish produced through recycling of organic manure is more healthy and has less fat accumulation.

Recycling systems require effective management. One of the problems is the difficulty in balancing the expertise needed in fish and animal husbandry. Over concentration on one system may result to the detrimental the other.

The monitoring of dissolved oxygen level in pond water is absolutely essential when the integrated systems are adopted. Excessive manuring causes water pollution. It rapidly decreases oxygen level in the water, produces toxic gases like ammonia often leading to fish kills. Application of manure should be regulated according to the dissolved oxygen level which is very essential for a rapid growth of fishes.

Animal excreta is a potential source of infection. However till now no serious health hazards were noticed. Further it was observed that the fermentation of the manure in biogas plant kills and destroys even the hardest eggs of parasites.

---

### 13.9 FISH CULTURE IN PADDY FIELDS

---

Rearing of fish along with paddy is a traditional practice in India. Integrated fish and paddy cultivation helps in resource utilization. Adaptation of the system in areas where rice fields are inundated and retain water for 3 to 8 months a year can provide additional crop of fish to the farmer, without decreasing paddy production.

Advantages of fish and paddy combined culture system are the control of insects and mosquito larvae by fishes, increased tillering action due to movement of fishes, check on the growth of weeds, manural value of fish excreta to the rice crop and utilization of algae by fish. Studies have also indicated that fish cultivation has no detrimental effect on the paddy, and on the other hand rice yield can be increased by about 10 percent.

Essential requirements of a paddy field suitable for fish culture are the construction of channels or trenches inside the field, and presence of a pit or sump near the outlet, having connection to all the channels in the field. Channels and pit apart from offering shelter to the fishes at the time of high temperature, helps in harvesting the fish. Strong, elevated dykes are necessary in order to maintain desired water depth and protect from floods. Provision of screens to inlets helps to prevent the entrance of unwanted fishes and escape of cultivated fishes. Fishes suitable for culture in paddy fields should be hardy to tolerate relatively high temperature, low dissolved oxygen level. They must have the capacity to thrive in shallow turbid waters and grow to marketable size in a short period. Major Indian carps catla, rohu, mrigal, exotic carps such as common carp, tilapia, murrel *Channa striata*, and *Puntius* sp, are found to suitable for culture in rice fields. Freshwater prawn *Macrobrachium rosenbergii* and fish *Puntius javanicus* could also be cultured along with paddy.

Brackishwater fish and prawns are cultivated extensively in paddy fields in Kerala and West Bengal. In Kerala, more than 5,000 hectares of tidal swept single crop paddy fields in the Vembanad lake region are being used for paddy cum fish culture. These fields are also called as 'Pokkali' fields. In these fields cultivation of paddy lasts for about four months from June to October. After harvesting the paddy, stumps remain rotting and contribute rich nutrients to the environment. It is in this condition that the field is prepared for brackishwater prawn and fish culture by strengthening the bundhs around the field. Swarms of postlarvae of prawns that enter into the fields along with the water current are retained there for the next few months for growth. Prawn and fish crop is harvested by draining the water through the sluices fitted with conical bag nets. Prawns *Penaeus indicus*, *Metapenaeus dobsoni*, *M. monoceros*, and fishes *Mugil sp*, *Etroplus suratensis*, *Chanos chanos* etc., contribute to the catch. Prawn production is reported to vary between 300 and 1,000 Kg per hectare per year. Major species of fishes and prawns cultivated are *Mugil parsia*, *M. ceros*, *M. brevicornis* etc. Production of fish and prawns in these fields varies between 100 and 300 and Kg per hectare.

Fish culture in rice fields is conducted in four types viz., catch on irrigated rice fields, secondary crop method, in the interval method and continuous culture method.

The catch on irrigated rice fields is a simple in which fishes entering into the rice fields along with water from irrigation canals are trapped and allowed to grow. Fishes are harvested along with rice crop. After harvesting the rice, fishes are cultivated as additional crop during the remaining period. In the interval method, fishes are cultivated during the short period available between the first and second crop of rice. In continuous culture system, both fish and paddy farming are conducted at the same time. Paddy is cultivated in multiple crops and while harvesting the paddy, fishes are retained in deep trenches constructed in the field.

In integrated fish and paddy culture system, fields are generally fertilizers at enhanced rates by about 50 to 100 percent more than the normal. Fertilizers used are the cattle dung, compost, nightsoil, bone-meal, urea, ammonium sulphate and super phosphate.

Paddy fields are utilized to conduct the fish breeding, rearing of fry to fingerling stage and culture of fishes upto marketable size. Breeding of air-breathing cat fish *Clarias* and large-scale collection of its seed from paddy fields exists in West Bengal.

Paddy cum fish culture in India is still in an empercial stage and there is vast scope for harnessing the land presently under paddy cultivation for fish culture along with paddy. It is desirable to take up paddy cum fish culture first in areas under influence of heavy rainfall during monsoon and where only single crop of paddy is cultivated at present.

---

### 13.10 FRESH WATER PRAWN CULTURE

---

Species of the freshwater prawn genus *Macrobrachium* are distributed throughout the world and over 100 species are known to exist. In India about 30 species are available. Among them, the giant freshwater prawn, *Macrobrachium malcolmsonii* are the two most favoured species for farming purposes in the country. Traditional culture of freshwater prawns exists on a limited scale in low-lying areas, paddy fields, ponds and tanks. Freshwater prawns are very popular, command good price, and also have high export value.

*M. rosenbergii* is considered as the most suitable prawn for freshwater farming in ponds. It occurs commonly in most of the rivers lakes, irrigation canals as well as estuaries in India. It is omnivorous and diet includes insects, algae, grain, seeds, small molluscs and crustaceans, flesh of fish and other animals. It readily accepts, supplementary feeds consisting plant and animal products. It can also be cannibalistic. *M. rosenbergii* is a fast-growing species and attains a maximum length of 300 to 320 mm. Male prawns are considerably longer than the females.

*Macrobrachium malcolmsonii* is an endemic species of India and is most common in rivers, lakes, irrigation canals and estuaries of peninsular India. It comprises the only freshwater

prawn of commercial importance in river Godavari. It has been recorded that the commercial exploitation of this species in river Godavari is extended upto Maharashtra, 800 KM away from the sea. *M. malcolimsonii* is a benthiphagic omnivore. Females grow upto 200 to 220 mm and males attain considerably larger size.

Spawning of *M. rosenbergii* takes place in the gradient zones of estuaries. The young post-larve ascend the rivers. Migrating juveniles are caught and reared in ponds. Juveniles are also entrapped in paddy fields. However, *M. rosenbergii* seed are not abundant in nature. Hence technique of seed production in indoor hatchery has been developed.

*M. rosenbergii* seed are not abundant in nature. Hence technique of seed production in indoor hatchery has been developed.

The egg laying occurs within a few hours of mating. Eggs are released into a brood pouch of the underside of the abdominal region of female prawn held in place by thin membrane and kept aerated by vigorous movements of the abdominal appendages.

Female prawns of *M. rosenbergii* are reported to lay about 60,000 to 1,00,000 eggs during one spawning. However, egg laying may vary from 5,000 to 3,00,000 eggs depending on the size of female. Eggs are slightly elliptical, bright orange in colour and before hatching they become greyblack. Eggs are incubated in the brood pouch and incubation time varies between 15 and 24 days. Egg hatching process is completed normally in one or two nights. The freshwater prawn larvae also known as zoeae are planktonic and swim actively tail first, ventral side upper most. They require brackishwater for survival. There are eleven microscopically distinct stages during the larval life of the giant freshwater prawn. The first stage larva is just under 2 mm long and by the eleventh stage it grows to over 7 mm long. Larval rearing is the most-critical phase in the freshwater prawn hatchery system.

Establishment of a freshwater prawn hatchery normally requires a coastal site, with abundant supply of freshwater. The hatchery system centres around the larval rearing tanks. Tanks made up of rigid plastic or fibreglass tanks are found to be most suitable. It has been observed that tanks made up of galvanized steel, concrete ore alloys of copper and zinc are toxic to larvae. Size of the tanks should not be too small or big but such that it must be accessible for feeding, cleaning and larval inspection.

In the freshwater prawn hatchery system developed indigenously for *M. rosenbergii* the larvae are reared in 200 to 500 F.R.P. tanks. The larvae are reared at a stocking density of 250 per litre initially and 20 to 40 per litre during the advanced stages. Sea water aged and diluted to 12 to 14 ppt. salinity is used for rearing the larvae. Optimum temperature for successful rearing is observed to about 28°C. Continuous aeration of water is carried out to maintain dissolved oxygen level above 4 ppm.

Different stages of prawn larvae are exclusively fed with minced tubificid worms, supplemented with brine shrimp (*Artemia*) nauplii. Rearing tanks are cleaned daily, and partial or complete change of water is carried. Larval development is completed in 30 to 45 days when the advanced larvae metamorphose into post - larvae, which are gradually acclimatized to fresh-water.

Post-larvae resemble miniature adult prawns and in the natural environment, post-larvae begin to migrate upstream into freshwater condition within one or two weeks after metamorphosis. They are able to swim against water currents, crawl at the shallow edges of rivers and climb vertical surfaces.

Freshwater prawns are cultivated in stock ponds, the same as used for carp culture. However, it is suggested that rectangular ponds of 0.1 to 1.5 hectares in size having water depth 1.0 to 1.5 metres with smooth pond bottom and drainage facilities are appropriate for efficient management. Continuous water flow, maintenance of water level and provision of hicc outs for the prawns are important requirements. Ponds with silty-sand substratum are most suitable. Muddy or clayey substrata are undetailed. Growth of aquatic vegetation along the pond bund only is allowed to minimise embankment erosion and to provide food and habitat for the prawns.

*M.rosenbergii* juveniles of 20 to 60 mm size are stocked in the ponds preferably during morning hours after gradual acclimatization. Stocking densities normally adapted are 25,000 to 30,000 juveniles per hectare which can be increased to 50,000 per hectare depending on the water supply. Higher stocking rates of about 2,00,000 per hectare also followed in some countries on the basis of culture system adopted.

Supplementary feeds such as broken rice, minced meat of molluscs shrimp or trash fish, tapioca and oilcake are fed to the prawns daily. The feed is kept in the pots provided in the pond. On the basis of nutritional requirements of the prawn, compounded diets are being prepared and used in various countries.

Healthy juveniles of *M.malcolmsonii* of 30 to 50 mm in size collected from riverine resources are stocked in the ponds, after removal of predatory fishes and liming. Stocking densities of 20,000 to 30,000 juveniles per hectare are considered as optimum.

*M. malcolmsonii* is cultivated by adopting either batch culture or continuous culture system. Batch culture technique is to stock the pond, allow the prawns to grow until the average market size is achieved and then harvest the whole crop. Continuous culture system consists of stocking the pond once or twice a year at higher densities and harvesting of market size prawns at regular intervals.

Low cost supplementary feeds such as broken rice, rice bran, minced, meat of apple snail (*Pila globosa*), trash fish, fish meal are used. Feeding rates are generally ranged between 5 and 10 per cent of prawn biomass. Strong territorial and cannibalistic nature results in the mortality of growing prawns. Provision of hideouts in the pond improves prawn survival rate.

Monoculture of *M.rosenbergii* at varying stocking densities resulted in the production of 577 to 606 Kg per hectare in four months growout period. Along with the prawns, compatible fishes can also be cultivated in the same period. Cultivated carps stocked with prawns reached marketable size and yielded 1,500 to 2,000 Kg. per hectare.

Production of *M.malcolmsonii* ranged between 256 per hectare in 6 months to 313 Kg per hectare in 10 months. By adopting continuous culture system, prawn yield has been improved considerably. In monoculture at 60,000 juveniles per hectare density, *M. malcolmsonii* production ranged between 534 and 690 Kg per hectare in 390 days growout period. In polyculture system of *M. malcolmsonii* and cultivated carps, prawn production corresponding to 634 to 962 Kg per hectare in 390 days in addition to fish production of 1,126 to 2,400 Kg per hectare was achieved. Through polyculture system, unexploited ecological niches in the pond can be profitably utilized. *M.malcolmsonii* is observed to be compatible with Indian major carps catla, and rohu while its growth rate and survival are adversely affected by exotic grass carp and common carp.

---

### 13.11 AIR-BREATHING FISH CULTURE

---

Commercially important air-breathing fishes of India are the murrels (*Channa marulia*, *C.striata*, *C.punctata*), climbing perch or Koi (*Anabas testudineus*), singhi (*Heteropneustes fossilis*), magur (*Clarias batrachus*), and featherbacks (*Notopterus chitala*, *N. notopterus*). These species, besides breathing through gills, are also able to take in atmospheric air directly and respire by means of accessory respiratory organs. By virtue of aerial respiration and other physiological adaptations, they thrive under extremely adverse environments of derelict and fallow water bodies such as swamps and weedy marshes where dissolved oxygen level is low and free carbondioxide content is high. Owing to their ability to live out of water, these fishes are marketed in live state, hence they are also known as "live fishes". Air-breathing fishes formed a major capture fishery from wild waters and they account for 15 percent of country's total marketable surplus of inland fish.

Air-breathing fishes are highly esteemed as food fishes for their flavour, taste, fewer bony elements and command higher price than carps in many states of India. They have high protein,

high iron and low fat content and hence are known for their nutritive, invigorative and therapeutic quantities and are recommended by physicians as diet during convalescence. It is perhaps for these reasons that though they are caught along with other fishes, they are displayed separately in the market. Moreover being hardy and capable of living out of water for a longer period, they do not die easily and can be kept alive in mudpots or wet cloth and thus ensuring freshness of the material. This is another reason for their popularity.

Murrels or snakeheads occur abundantly throughout India and they inhabit tanks, lakes, reservoirs, and rivers. Giant murrel, *Channa marulia*, striped murrel *C.striata* and spotted murrel, *C.punctata* are found to be suitable for culture. Adult fishes are typically carnivorous and are also cannibalistic. *Anabas testudineus* is widely distributed throughout the country and it is a delicacy to the consumers in north-eastern region of India. The fish is well known for its capacity to walk over land during rains. *Heteropneustes fossilis* occurs in freshwater swamps and tanks throughout India and is best known for its nutritive and restorative qualities. *Clarias batrachus* occurs in fresh and brackishwater areas throughout the country. *Notopterus chitala* and *N.notopterus* are commonly found in rivers, lakes, reservoirs and big lakes. They are preferred food fishes in north-eastern states of India.

---

### 13.12 TECHNIQUES OF SEED PRODUCTION

---

Air-breathing fishes generally breed in low-lying inundated areas, paddy fields, swamps, ponds, tanks, lakes, reservoirs as well as in rivers. Breeding season normally coincides with monsoon, postmonsoon months. They exhibit parental care. Much of the seed is procured from natural resources, and techniques of controlled spawning have also been successfully conducted.

Commercially important murrels *Channa marulia*, *C. striata* and *C.punctata* breed in confined waters and the spawn or fry of murrels occur in shallow rain filled puddles, ditches and in seasonal or perennial tanks. The giant murrels, *C.marulia* breeds throughout the year with peak period immediately preceding and during monsoon months. *C.punctata* breeds from April to October but in the Telangana region in Andhra Pradesh, it is reported to breed throughout the year. Bright colouration of the young ones in the form of vermilion red in *C.striata*, iridescent lemon yellow with black bands in the case of *C.punctata* and orange yellow longitudinal band on each side of the body in *C.marulia*, help in locating and identifying the seed. Collection of murrel seed should be attempted while they are in the early fry stage itself because as they lose shoaling tendency. Collection of the seed shoal is done by carefully circumventing them with the help of cloth net and thereby taking them out with a quick haul.

Induced breeding of murrels is conducted by injecting homogenised carp pituitary glands. Dosage required for successful spawning range from 80 to 120 mg per Kg body weight to females, and 15 to 40 mg per Kg body weight to males. After spawning eggs are transferred to plastic basins. Continuous dripping of water into the basin helps to obtain high survival of developing embryos. Period of egg incubation vary between 24 and 26 hours in *C.marulia*, 45 and 55 hours in *C.striata* and 20 and 28 hours in *C.punctata*.

Hatchlings are maintained in the basin with a depth of water not exceeding 25 cm. Zooplankton such as rotifers and cladocerons are provided as food for them for 8 to 10 days. Thereafter the young ones are transferred to cement cisterns for further rearing.

The climbing perch, *Anabas testudineus*, generally breeds once in a year between May and October, and its fry are best retrieved by using small mesh cast nets. It has been often observed that *Anabas* migrates into prepared carp nurseries and breed there. It is possible to harvest about 2,000 to 4,000 fry from such ponds. *Anabas* can be easily induced to breed through hypophysation in aquaria, cement cisterns, or hapas installed in ponds. To achieve successful spawning a single dose of pituitary at the rate of 25 mg per Kg to female breeder and 12 mg/Kg to the male is necessary. Incubation period is 18 to 20 hours.

The newly hatched larvae of *Anabas* are very small 1.9 mm in size and are susceptible to attack by zooplankton *Cyclops*. Hatchlings are dependent on minute organisms such as protozoans for their food. At 5 mm size, they can feed on rotifers and small cladocerans.

The singhi, *Heteropneustes fossilis* is observed to breed during monsoon months June to September, and it has also been reported that singhi breeds several times during the breeding season at short intervals. Eggs are round, adhesive and green in colour. The seed of *H.fossilis* are collected by placing earthen pitchers in the natural habitat. *H.fossilis* was successfully bred through hypophysation and dosage generally recommended is 10 to 20 mg carp pituitary glands per 100 g of the body weight of the females. It is found that spawn survival and growth is better when water depth is below 50 cm. Hatchling prefers to feed on protozoans particularly ciliates. When the fry are more than 15 days old and about 40 mm in length cement cisterns at a density of 1,500 numbers per sq. meter. Water depth in the cement cistern is maintained below 45 cm level.

*Clarias batrachus* generally constructs nets in the form of a hole in the muddy embankment. It is difficult to locate the nest, but once the nest is located, fry can easily be collected. *Clarias* prefers paddy field for breeding. The young once are also collected by fixing up traps at the outlets of paddy fields. *Clarias* was successfully bred by both homoplastic and heteroplastic pituitary extract injections. A single massive dose of major carp pituitary gland at the rate of 100 to 150 mg per Kg body weight of recipients has proved quite satisfactory. Low survival of the developing eggs and hatchlings is the major problem encountered. However, breeding of magur in paddy fields has given encouraging results.

The feather backs *Notepterus chitala* and *N. notopterus* breed in confined waters during monsoon. Fertilized eggs are demersal and adhesive in nature. Hatching takes place after nine days under normal conditions.

---

### 13.13 CULTURE OF AIR-BREATHING FISHES

---

Murrel culture was attempted for the first time at Sunkesula fish farm (Andhra Pradesh), and later on followed at Hyderabad and Bombay. It was observed that the murrels prefer to feed on soft bodied forage fish such as minnows and it has been suggested that before releasing the murrel fingerlings of 70 to 100 mm size, stock ponds are to be prepared two to three months earlier by introducing forage fishes and allowing only marginal weeds to harbour aquatic insects.

In Karnataka open stocking of swamps with *C.marulia* has resulted in a production of 2,000 Kg per hectare per year and with *C.striata* production as much as 895 Kg. per hectare per year was obtained. Murrels have fed on self-generating stocking of minnows and other trash fishes. Open stocking of murrels *Channa marulia* and *C striata* in swampy derelict pond gave a production of 2,600 Kg per hectare per year without fertilization.

Recent studies in Andhra Pradesh on pond culture indicated that supplementary feeding is essential in murrel culture. Conventional supplementary feeds of plant origin (such as rice bran and oil cake) are not acceptable to murrels, and animal protein in the form of flesh promotes good growth as well as survival of murrels.

Murrel culture is a shallow water culture system like the culture of any other air-breathing fish. In low water column, the energy loss by the fish due to their vertical trips for aerial respiration is less, resulting in efficient food conversion and faster growth.

Culture of magur, *Clarias batrachus* and singhi, *Heteropneustes fossilis* are oriented to shallow water environment. Various systems have been developed for culturing these cat fishes Viz., cage culture, culture with aquatic cash crops like makhana (*Euryale*) or singhra (*Trapa*), culture in carp nurseries, culture along with carps, and culture in sewage waters.

Singhi, *H. fossilis* is compatible with *Clarias* and *Anabas*. In addition it has considerable potentialities for monoculture under semi - intensive systems. Among the air-breathing fishes, *Heteropneustes fossilis* is the hardiest fish and its farming involves less risk and needs less strenuous management.

Monoculture of *Anabas* in a swampy pond in Bihar indicated a production of 254 Kg per hectare in three months, and in West Bengal, at a stocking density 1,25,000 fingerlings per hectare gave a production at the rate of 702 Kg per hectare in eleven months. Culture of *Anabas* in barrel-shaped bamboo cages (1.5 m length and 1 m diameter) resulted in a production of 27 kg per cage in five months.

Development of air-breathing fish culture systems has special significance to Andhra Pradesh. Air-breathing fishes contributed about 25 per cent of inland fish production of the state and Kolleru lake is an important air-breathing fish producing centre. Hyderabad is a major marketing centre for murrels.

### Check Your Progress

- 1) Fish cum \_\_\_\_\_ or Fish cum \_\_\_\_\_ or Fish cum \_\_\_\_\_ Culture is profitable.
- 2) The cultivable fresh water prawns are species of \_\_\_\_\_

---

### 13.14 SUMMARY

The merits of Composite Fish Culture is described here. The fish that are cultured compositely are Indian major carps such as Catla, Rohu, Mrigal, Chinese Silver Carps, Grass Carp etc.

Fish cum duck culture is also in vogue and it yielded good results of the same described here.

Fish cum poultry culture is also explained here.

Fish cum pig culture also yields good results. Fish culture cum, cattle management is also explained here. Fish culture in paddy fields is quite economical and profitable so these techniques are described here. Fresh water prawn culture is also explained. Air-breathing fish culture techniques are also explained here.

---

### 13.15 CHECK YOUR PROGRESS - MODEL ANSWERS

1. Duck  
Poultry  
Pig
2. Macrobrachium

---

### 13.16 MODEL EXAMINATION QUESTIONS

I. Answer the following in about 30 lines.

1. Write about the composite fish culture technology of Indian major carps and exotic carps.
2. Give an account of costs and income from a composite fish culture pond.
3. Describe the fish cum duck culture system.

4. Explain the fish cum pig culture system.
5. Give an account of the utilization of biogas plant slurry in fish culture.
6. Write about the fish culture in paddy fields.
7. Describe the seed production and culture of *Macrobrachium rosenbregii*.
8. Write about the culture of *Macrobrachium malcolmsonii*.
9. Describe the seed production techniques of air breathing fishes.
10. Write about the culture of murels.

**II. Answer the following in about 10 lines.**

1. Water management in composite fish culture ponds.
2. Feeding habits of Indian major carps and exotic carps stocked in composite fish culture ponds.
3. Species combinations in composite fish culture System.
4. Fish production in composite fish culture ponds.
5. Economic analysis of traditional fish culture practice.
6. Advantages of integrated systems.
7. Fertilizer value of poultry droppings.
8. Breeding of *Macrobrachium malcolmsonii* in Godavari river.
9. Commercially important air-breathing fishes of India.
10. Culture of *Clarias batrachus*.

---

# UNIT - 14 COASTAL AQUACULTURE AND MARICULTURE SYSTEMS

---

## Contents

- 14.1. Objectives
- 14.2. Introduction
- 14.3. Brackishwater Prawn and Fish Culture
- 14.4. Prawn and fish seed production
- 14.5. Nursery Management
- 14.6. Brackishwater Prawn and Fish Farming
- 14.7. Mariculture Systems
- 14.8. Mussel Culture
- 14.9. Oyster Culture
- 14.10. Clam Culture
- 14.11. Pearl Culture
- 14.12. Problems and Constrains of Bivalve culture systems
- 14.13. Fish Culture
- 14.14. Sea Weed Culture
- 14.15. Summary
- 14.16. Check Your Progress - Model Answers
- 14.17. Model Examination Questions

---

## 14.1 OBJECTIVES

---

Brackishwater prawn and fish farming and important mariculture systems such as mussel culture, oyster culture, clam culture, pearl culture and sea weed culture are described in this unit.

---

## 14.2 INTRODUCTION

---

Brackishwater prawn and fish culture is traditionally practiced in West Bengal and Kerala. Traditional system is based upon trapping the natural seed, holding and fattening them in impounded tidal swamps and coastal paddy fields. Major defects in traditional culture and the large-scale wastage of juvenile stocks of desired species, uncontrolled species composition and density, and low as well as unpredictable production. Researches carried out since last decade have laid the foundation of scientific brackishwater aquaculture technology and enhanced the yield potential to an appreciable extent. Prawns are the primary cultivated organisms in coastal aquaculture system. *Penaeus mondon* and *P.indicus* are the most preferred species for culture due to high market price, quick growth-rate and other biological factors. Milk fish *Chanos chanos*, grey mullet *Mugil cephalus*, mullets *Lize tade*, *L.parsis* and *bhetki Lates calcarifer* are the candidate

species of fishes suitable for brackishwater culture. Commercially important prawns and fish seed are obtained either by collecting from their natural environment or by producing them in hatcheries under controlled conditions. Brackishwater farming in India at present depends on the stocking material available from nature. Observation on seasonal availability, abundance and suitable gears for collection of prawn and fish seed have been carried out in different brackishwater areas situated along the east and West coast of India, including Godavari estuary, Kakinada bay and Pulicat lake of Andhra Pradesh. Controlled breeding of cultivated prawns and hatchery production of their seed is a recent development in India. Nursery management of prawn and fish seed is an important primary step in brackishwater aquaculture. Nursery preparation and management methodology suitable for individual species are described. Scientific management of methodology suitable for individual species are described. Scientific management of brackishwater stock ponds with particular reference to ponds preparation, water management, fertilization, stocking and supplementary feeding are presented in detail. Brackishwater farming is conducted by adopted either monoculture or polyculture systems. Single stocking and single harvesting, single stocking and repeated harvesting and repeated stocking and repeated harvesting methods, as well as species combinations and densities tested are discussed. It is possible to achieve tiger prawn *Penaeus mondon* total production about 1,000 Kg per hectare per year through short duration multiple crops. Polyculture of prawns and fishes has resulted in a significant production of 2,671 Kg per hectare per annum. Organised culture of marine organisms in sea water is termed as mariculture. Culture of bivalve molluscs is the priority area of mariculture in India. The green mussel *Perna viridis* and brown mussel *Perna indica* occur in India. Rope culture of mussels has resulted in the production corresponding to 450 tonnes per hectare of *P. viridis* and 150 tonnes per hectare of *P. indica*. Oysters *Crassostrea madrasensis*, *C. gryphoides* and *C. discoidea* occur in estuaries, backwaters and creeks. By adopting the rack- and-tray culture method average annual production 0.48 tonnes per rack i.e., they could achieve about 135 tonnes per hectare of *C. madrasensis* was achieved. Clams are the most important bivalve resources in India. The blood clam or cockle *Anadara granos* is experimentally cultured in the subtidal area of Kakinada bay and production rates corresponding to 3.8 to 41.6 tonnes per hectare were obtained. Pearl oyster *Pinctada fucata* occurs naturally in the Gulf of Mannar and Gulf of Kutch. Formation of natural pearl is influenced by foreign bodies accidentally entering the body of pearl oyster. Under the stimulus of foreign body, outer epithelium of the mantle invaginates, forms a pearl-sac and leads to the formation of pearl. In the cultured pearl technique, a small piece of mantle from a donor oyster is grafted into the gonad of the recipient oyster together with a highly polished 2 to 7 mm spherical shell bead known as nucleus, by skilful surgery. Raft culture is the typical method of pearl oyster farming in sheltered bays. Among the finfish, suitable method of culturing the eel, *Anguilla bicolor* in running waters is developed. Attempts are being made to develop the culture of economically important sea weeds.

---

### 14.3 BRACKISHWATER PRAWN AND FISH CULTURE

---

Brackishwater is a mixture of marine and freshwater. It is found in estuaries, backwaters, tidal swamps, coastal lakes and lagoons. The fauna of brackishwater is composed of a wide variety of organisms such as marine and freshwater forms, which migrate to brackishwater areas for purposes of feeding, breeding and larval development, in addition to typical resident brackishwater species.

Prawns are the primary cultivated organisms in brackishwater aquaculture system. Only the euryhaline forms that can withstand the fluctuating salinity for culture. In the coastal waters of India, 27 species of prawns belonging to penaeidae occur, of which 11 species are found to be suitable for culture owing to high market price, attractive sizes, growth and other biological factors. These are *Penaeus mondon*, *P. indicus*, *P. semisulcatus*, *P. merguensis*, *Metapenaeus monoceros*, *M. affinis*, *M. dobsoni*, *M. brevicornis*, *Parapenaeops stylifera*, *P. sculptilis* and *P. hardwickii*. However the most preferred species for culture are the tiger prawn *Penaeus monodon* and white prawn *P. indicus*.

Candidate species of fin fish suitable for brackishwater culture are the *Chanos chanos*, *Mugil cephalus*, *Liza tade*, *L. parsia*, *L. macrolepis*, *Lates calcarifer*, *Megalops*, *Elops saurus* and *Etroplus suratensis*.

#### 14.4 PRAWN AND FISH SEED PRODUCTION

Availability of adequate prawn and fish seed is the prime requisite in organising large-scale coastal aquaculture operations in the country. Prawn and fish seed can be obtained either by collecting them from the natural environment or by producing them in hatcheries under controlled conditions. The brackishwater prawn and fish farming in India at present depends on the stocking material available from nature.

All the commercially important penaeid prawns breed in the sea at different depths. Penaeid eggs hatch and metamorphose through four distinct stages : nauplius, zoea, mysis and post-larva. Generally six nauplii, three zoea and three mysis substages are recognized. Post-larval stages enter the brackishwater areas along the coast as part of planktonic mass migration. The brackishwater areas offer the required ecological niches and act as nurseries for their growth. Prospecting of larvae to juveniles in these nursery areas has received considerable attention for procurement of seed for aquaculture.

Availability and abundance of the prawn seed have been related to several ecological and meteorological variables such as salinity, temperature, rains, river discharges, current, depth, plankton, lunar cycles, seasons, mangrooves, mud banks and pollution.

The post-larvae and juveniles of *Penaeus monodon* are abundantly available, through out the year in Hooghly-Matlah estuarine system in West Bengal, with peaks during April to May and October to November. Midnapore type shooting nets are used to collect the seed in large quantities.

In the vicinity of Kakinada bay post-larvae and juveniles of *P. monodon* are available throughout the year with peak during May- July and September to December. Because of lower tidal amplitude, consequent lower velocity of water and the type of ecosystem with bush type mangrooves at Kakinada, hand net is found to be most effective to collect the tiger prawn seed. In Kakinada, *Penaeus indicus* seed are also available through out the year with peak during April to June, and August to September. In Hooghly- Matlah estuary and Pulicate lake the peak seasons of *P.indicus* are January, March and August.

Fry of milk fish, *Chanos chanos* are available on the east coast of India from Srikakulam through East Godavari to Nellore districts in Andhra Pradesh. In Tamilnadu, Pamban, Ramnad district is a major collection centre. On the west coast it is available in Malabar in Kerala and south Kanara in Karnataka State. In Kakinada area, *C. chanos* seed are available for restricted period during March-July with major peak in April to June, and sometimes also available as minor peak from October to early December. Milk fish fry have a tendency to swarm in shoals in shallow tidal creeks and inter-tidal pits. Drag net is found to be most suitable to collect milk fish seed. Fry of grey mullet, *Mugil cephalus* are available at Kakinada in a brief seasonal peak from November to December. Other mullets seed are found to occur at Kakinada throughout the year with peaks during April to June, November to December. The young ones of *bhekti*, *Lates calcarifer* are available in small quantities at Kakinada during October to November.

Owing to seasonal fluctuations, the seed collected from natural sources cannot always be depended upon for the large-scale prawn and fish farming. The only way to get a dependable supply of seed is by producing them under controlled conditions. Controlled breeding and production of seed cultivated prawn and fish species through hatchery system is a recent development in India.

In nature the penaeid prawns attain full sexual maturity and breed in the sea. The age at which the prawns attain maturity varies with the species. *Penaeus monodon* matures at 5 to 15 months age, and *P.indicus* at about 4 to 6 months age.

Hatchery operations start with procurement of spawners. Mature adult prawns captured from nature, or spawners induced to mature by eyestalk ablation are used for spawning in the hatchery.

The hatchery systems developed over the year can be broadly classified as two types: (1) The Japanese method of mass culture system of simultaneously spawning a number of spawners in large cement concrete tanks where the sea water is fertilized to develop food organisms, and (2) a closed cycle hatchery system of the Galveston laboratory, U.S.A., in which the spawning is conducted in small fiberglass tanks and the larvae are fed from external source of separate live-feed cultures. In India mass production of penaeid larvae is successfully achieved using modified Galveston type hatchery system.

Availability of clean, unpolluted sea water with minimum seasonal fluctuations in quality is most desirable factor to establish the hatchery. Good source of freshwater, spawners availability, approach road facilities, electric supply and generator are the facilities required to operate the hatchery. Supply of oil-free air through air-pipes or air-blowers with air-stones to help aeration and water is most important for successful larval rearing. Cylindrical plastic pools of 300 liters capacity, rectangular or circular plastic containers of varying capacities ranging from 1.75 to 10.5 tonnes, fibreglass containers cylindrical in shape with conical bottom to drain out water and metabolites are used in India.

In hatchery tanks fresh sea water having a salinity range 28 to 34 ppt is passed after filtering. Earlier to release of spawners in the tanks, sodium salt of EDTA is added to the water at the rate of 1 g.per 100 litres. Spawning usually occurs in night, and eggs hatch to nauplii 12 to 15 hours after spawning. *Penaeus monodon* has six nauplius stages and the nauplius grow by subsisting on the reserve yolk. The intermoult period between two subsequent moults is 8 to 12 hours. The nauplius metamorphoses into zoea. Zoeal stages start feeding on diatoms. After moulting three times in about four to six days, zoea becomes mysis. Mysis stage in addition to feeding on diatoms starts consuming the larvae of zooplankton. Mysis stage is complete in about 4 to 6 days and it is followed by the post-larval stage. Water temperature seems to affect the rate of development of the larval shrimp. Optimum water temperature is 28 to 29° C.

Key factor of successful hatchery operation is the availability of appropriate feed for prawn larvae and it is the factor that makes it a complicated operation. Among the diatoms *Skeletonema* spp., *Cheateoceros* spp. are preferred and raised in separate algal culture tanks in the hatchery. Continuous culture system of rotifer *Brachionuous Plicatilis*, cladoceran *Moina* spp., and brine shrimp *Artemia* have been developed to supply live feed. Egg custard, tissues suspension made out of freshly ground *Acetes* spp., ground tissues of juvenile penaeid prawns and the stomatopod *Oratosquilla nepa* are also being successfully used. Finely minced clam meat is given as food to the post-larvae.

Among the fishes, grey mullet *Mugil cephalus* and other mullets were successfully spawned through induced breeding. However, hatching and rearing of larvae in large scale is yet to be perfected.

---

## 14.5 NURSERY MANAGEMENT

---

The freshly collected prawn and fish seed are too delicate to adjust to the conditions of impoundments and hence they suffer large-scale mortality if directly transferred to stock ponds. Therefore, prawn and fish seed are first introduced into small enclosed where favourable physico-chemical conditions and necessary food can be provided. These small enclosures are termed as nurseries. Nurseries may be earthen ponds of 0.05 to 0.1 hectare area or they may

be cement cisterns of varying size. Hapas and cages kept in brackishwater farm ponds are also used as nurseries.

The earthen nursery ponds are prepared by draining out the water and phosphatic fertilizers are added to the ponds soil at this stage to encourage growth of natural food organisms. Tidal water is then drawn into the pond and allowed to stand at a depth of 0.3 metres for about 10 days and when thick growth of algae is noticed, the water level is raised gradually.

Nurseries are prepared on the basis of requirements of individual species to be reared. Food is one important factor. Post-larvae and juveniles of prawns feed microscopic algae, and decaying vegetable matter. Benthic algae 'Lab-lab' is necessary for milk fish. Mulletts prefer zooplankton. Other factors to be maintained in nurseries are the level of dissolved oxygen, salinity and pH. Dissolved oxygen above 4 ppm, salinity between 10 to 15 ppt and pH about 8 are favourable. These are controlled by frequently changing the water.

Care must be taken to guard the inlets and outlets with close-meshed screens in order to avoid the entry of unwanted organisms and prevent the escape of stocked species. Before introducing the post-larvae in prepared nurseries, they are gradually acclimatised, through graded mixing of nursery water. Keeping the date palm leaves, dried twigs of local mangrove plants in the pond at different points will provide shelter while moulting and serve as a substratum for the prawn to rest on. Regular exchange of tidal water with pond water is essential.

Stocking of *penaeus monodon* post larvae may be done at the rate of 3 to 5 lakhs per hectare in a well prepared nursery. Supplementary feed in the form of finely ground trash fish, trash prawns, fish meal or molluscan meat should be given every day at the rate of 10 to 20 per cent body weight. In 6 to 8 weeks the post-larvae of 10 to 15 mm will grow to 40 to 50 mm size. They can be taken out for stocking in bigger ponds.

In milk fish *Chanos chanos* nurseries, water level is kept at 0.5 to 0.8 metres to encourage the growth of lab-lab. Milk fish fry of 10 to 15 mm are stocked at the rate of 3 lakhs per hectare. Supplementary feed comprising the powdered cereal, oil cake, and fish meal mixed in equal proportions is to be provided every day at 10 percent of total body weight of the stocked fry. Milk fish fry are found to grow 40 to 100 mm in two months.

Mullet nurseries are prepared in the same way as milk fish nurseries. Fry of 20-25 mm size are stocked at the rate of 1 lakh per hectare. Supplementary feed of ricebran and oil cake is given at a daily rate 5 to 10 percent of body weight of the fishes. After 40 days rearing juveniles can be transferred to production ponds.

---

## 14.6 BRACKISHWATER PRAWN AND FISH FARMING

---

Tidal mudflats, mangrove areas, coastal swamps, marshes and intertidal zones away from the estuaries are potentially suitable areas for brackishwater aquaculture. Besides these areas coastal paddy fields and salt pans could also be advantageously used in some seasons.

Information of assured source of water supply, geographical and climatic conditions, tidal amplitude in relation to the site, duration of tidal influence, nature of soil and water, type and density of vegetation, availability of stocking material in the vicinity, freshwater run off, pollution free environment, road and communication facilities, legal and social problems, is essential in deciding the merits and demerits of brackishwater pond site.

Basically a constant supply of brackishwater must be available to the ponds throughout the year. This serves to exchange water from the confined pond, and to replace water lost through seepage and evaporation.

Supply of water to the farm should be as far as possible through natural creeks, which are connected to the estuary, brackishwater channel or bay itself. Another method of water supply is by pumping. Electric and diesel pumps are used and wind mills can also be utilized.

An ideal site, from the cost of construction point of view would be one which gets required one metre water level on the site for 7 to 8 days in a fortnight, by gravity.

Soil type, its texture and properties are important factors in the selection of site. Sandy-clay soil is good for prawn culture and clay-loam soil is also acceptable. Soils having more than 70 percent sand content will not be good for brackishwater farm construction, and embankments will not have stability.

Contour survey is to be undertaken in order to make out the size and shape of land in relation to water source. Planning, design and construction of coastal aquafarm depend upon the types of farm and systems of farming. That is whether the farm is for tip-fed farm or pumped farm, prawn culture or polyculture system.

Brackishwater fish farm will have a complex of ponds for different purposes. Stock pond is the production unit in a farm. Depth of the pond is determined by contour survey and design of farm. Shallow ponds of about 1 metre water column is advocated to maintain a balanced growth of required food organisms in the pond. Rectangular shape helps easier netting of the ponds. Stock ponds having minimum 0.5 hectare water area is considered suitable for economic management. Nursery ponds are useful for seed rearing and production. Nursery ponds 0.05 to 0.1 hectare water area are easy to manage. While digging the ponds in brackishwater area, top soil which is fertile should be kept aside, in order to spread it later on when the ponds are ready for use.

Brackishwater fish farm, in addition to the ponds consists of four main constituents: (1) peripheral dyke to protect the farm from strong tidal action, (2) secondary dyke inside the farm separating the ponds with secondary sluices for inlet and outlet of water, (3) master sluice which controls water flow-in system of the entire farm, and (4) feeder channel leading from the master sluice. It distributes water to the ponds and also acts as a reservoir. Secondary feeder channels may branch off from here depending on the design of farm.

Scientific management of brackishwater stock pond starts with improvement of the ecology of ponds to suit the species cultured. Fluctuation in salinity level is a characteristic feature of brackishwater, and salinity is a major factor that influences other physico-chemical and biotic features in the ponds.

Control of these unstable ecological factors and their better utilization for the benefit of stocked prawns and fishes to obtain increased growth rate and survival are the primary objectives of brackishwater farm pond management.

Management of brackishwater farm ponds generally centres around (1) pond preparation to receive the stock for culture, (2) water management to provide congenial environment, (3) care for the growing stock by way of providing supplementary feeding, and (4) harvesting at appropriate time to get better yield.

Pond preparation is the most important stage before stocking.

Prior to the stocking of juveniles in pond, eradication of the pests and predators, and removal of metabolites and excessive silt from pond bottom are essential. Water loaded with metabolic wastes and deficient in nutrients from the previous culture is to be drained out completely and the pond bed is exposed to sun for drying. This eliminates predatory fishes and unwanted prawns from the farm pond. Exposure of bottom soil to sun and removes all toxic gases accumulated in the mud, and quickens the mineralization of settled detritus and decaying organic matter. The silt brought in through the tide water and dyke washings might be reducing the effective depth to pond. If any heavy siltation is noticed the added silt should be removed after drying.

The burrowing organisms like eels, crabs, molluscs are eradicated by applying organic toxicants like mahua oilcake, tobacco dusts etc., at the rate of 100 to 150 Kg per hectare. For the purpose of eradicating burrowing organisms, toxicant is spread evenly over the dried pond bed and water is drawn into the pond slowly upto a depth of 2 to 3 inches. Toxin dissolves in water and enters

into burrows and crevices to kill the unwanted organisms. After 3 days, water is drained out and the pond bed is flushed with tidal water to wash away the toxic effects and make it ready to receive fertilizers. Screening of inlet and outlet with fine bamboo mesh or nylon cloth netting is essential to prevent the entry of harmful organisms and escape of stocked prawns and fishes. Application of lime 100 to 200 Kg per hectare improves the soil and water quality.

It is necessary to apply fertilizers in order to improve the natural productivity of the pond and encourage the growth of prawn and fish food organisms. Majority of the cultivated brackishwater prawns and fishes prefer benthic organisms as their food. Hence soil fertilization is more effective in brackishwater ponds. Pond soil may be tested to know the deficiency, if any, of nutrients, salts and organic carbon. A combination of both organic and chemical fertilizers is considered more effective. Depending on the quantum of organic content in pond soil, the amount of organic manure required is determined. Generally, the quantity of organic manure required ranges between 1,000 to 3,000 Kg per hectare.

A basal dose of organic manure like poultry droppings, cattle dung at the rate of 100 Kg per hectare along with area and superphosphate about 20 Kg per hectare each, on monthly basis results in thick growth of benthic algae at a salinity range of 5 to 20 ppt. With the increase in salinity, dosage of manure is to be increased. After the application of manure, water is drawn into the pond to a depth of 20 cm and allowed to stand for 5 to 6 days and later filled to capacity. To sustain the growth of benthic organisms algal mats and plankton, water level in the pond is to be maintained at 1.0 to 1.2 metres when fertilizers are applied at required quantities.

The natural fertility of brackishwater is made use of to the maximum extent by frequent exchange of pond water with tide water. Fresh tide water in addition to replenishing the nutrients also brings in fish food organisms. If fertilizers are applied in the pond, minimum 8 to 10 days time may be given between fertilization and water exchange, unless during water exchange the outgoing water will carry away part of the added nutrients. Fluctuating salinity modifies the effect of fertilizers. During low salinity regimes, fertilizers are found to be more effective. Under high salinities, phosphorus remains fixed in non-available form in the soil-phase without appreciable release into water-phase.

Quality of water determines the growth, health and survival of prawn and fish stock under cultivation. Good quality water for aquaculture should not be overloaded with metabolites produced by a crowded fish stock and should be free from pollutants. High turbid and silt laden waters are also not suitable for raising brackishwater fish. Eventhough the species selected for cultivation are euryhaline, abrupt change in temperature, pH, salinity, dissolved oxygen is likely to upset the physiological adaptations. Stress caused by unfavourable water quality factors will reduce the resistance of cultivated species to diseases and pests.

Care should be taken to maintain the water quality. Regular exchange of water is an easy way to check the bad effects of unfavourable physico-chemical factors in brackishwater farm. Under normal conditions, water from the farm ponds is exchanged 3 to 4 days during spring tide at fortnightly intervals. Flow created by exchange of water removes the metabolites and maintains the important physico-chemical and biological properties of pond water. Aeration by mechanical devices is another method to improve the pond water quality. Periodic checking of water quality is to be conducted to maintain salinity between 5 to 20 ppt, dissolved oxygen above 4 ppm and pH around 8.

After the preparation of pond bottom and allowing necessary amount of water to grow the natural fish food, pond is ready to receive the stock of prawn and fish. Ponds should be stocked with desirable species of prawns and fishes.

Brackishwater farming is conducted by adopting either monoculture or polyculture systems. Culture of a single species is known as monoculture. In this system only one species of prawn or fish is stocked in the pond and reared till they attain marketable size. This system is followed to take advantage of a particular set of optimum conditions.

Monoculture is conducted in different methods viz., 1) single stocking and single harvesting, 2) single stocking and repeating harvesting and 3) repeated stocking and repeated harvesting. In single stocking and harvesting method advance juveniles of a species are stocked, reared and harvested when they attained marketable size. Tiger prawn *Penaeus monodon* is cultured in this way from February to June, or June to October ponds are stocked with 40 to 60 mm length juveniles of *P. monodon* at a stocking rate 15,000 to 30,000 per hectare and with a growth period of two or four months, prawns weighing more than 25 grams could be harvested.

In single stocking and repeated harvesting process, fry and advanced juveniles of different size groups are stocked together. Larger individuals are harvested earlier, and smaller ones are allowed to grow for progressive periods of time before harvesting. In the third method of repeated stocking and repeated harvesting, juveniles of same size group or different size groups are stocked at high densities. They are partially harvested after a specific rearing period, restocked with smaller size group juveniles, and this process is repeated. With judicious management of stock manipulation, third method has been found to be very efficient in monoculture system.

Another means of increasing production in brackishwater aquaculture is the polyculture system in which two or more species with compatible behaviour and feeding habits are raised in the same pond. Criteria followed in selecting the suitable candidate species for polyculture in brackishwater are non-predatory in feeding habit, capability to tolerate fluctuations in salinity and temperature, rapid growth rate, ability to accept natural as well as supplementary feed, and good market demand. Based on these criteria, important prawn and fish species considered suitable for stocking are the *Penaeus monodon*, *P. indicus*, *Chanos chanos*, *Mugil cephalus*, *Liza tade* and *Liza parsia*. In addition various other penaeid and metapenaeid prawns are also stocked in polyculture system depending on the seed availability.

In polyculture system prawns and fishes are stocked in appropriate combinations.

It is necessary to provide supplementary feed to the prawns and fish to maintain the growth.

Supplementary feed ingredients are generally agricultural and animal by products. Rice bran, wheat flour, maize powder, oil cake, fish meal, prawn meal, minced meat of molluscs, slaughter house wastes are commonly used. In deciding about the composition, it is generally found that a protein content of a minimum of 18 to 20 percent is required. In prawn farming various results indicate that protein content between 40 to 60% are better utilized by the prawns. Use of fresh and dry food in combination, use of proteins of animal and vegetable origin in combination are found to yield better results. Feeds commonly used are in powdered form. They are mixed with water made into thick paste and kept in feeding plates in the pond. Palletized feed is the current method of feed supply to prawns and fish. In this method required feed ratios can be formulated, compounded and made into pellets. Pollution is less, and loss of feed by way of dissipation is minimized.

Feeding of prawns and fish should be done daily and quantity of supplementary feed should be given at the rate of 1 to 5 percent weight of total stocked population. Owing to high costs of feeds, supplementary feeding is undertaken only to complement the natural food augmented through fertilization. Thus the amount of supplementary feed required depends on the nature and quantum of the natural food produced, pattern of feeding and the system of culture.

One of the principle problems faced in shrimp culture is harvesting. The total harvest of prawns and fishes is possible only by draining the pond since major portion upto 80 to 90 percent of prawns will remain in the pond even after repeated nettings. The draining can be done by gravity flow through sluices during low tide. However, at certain level water is to be pumped out. After the entire pond is drained hand picking of prawns is done.

The feeder channel in the brackishwater farm is generally not used for raising fish. This water area can be used to culture carnivorous fish like *Lates calcarifer*. A simple process to let in fish and prawns along with tidal ingress to serve as food for *Lates* has enabled production 2,760 Kg per hectare per annum.

## 14.7 MARICULTURE SYSTEMS

Organised culture of marine organisms in sea water is termed as mariculture. Marine farming is generally conducted in the edge of the sea, its inlets, in bays etc.

Bivalves such as mussels, oysters, clams and cockles are widely distributed throughout tropical waters. Typically they occur in mangrove areas or in coastal regions where, following a brief period of juvenile motility, they attach to rocks and other static objects. In India, it is a tradition to collect the naturally occurring molluscs as a cheap source of food. It has been demonstrated that it is both technically and economically feasible to culture bivalves to produce a marketable product in high yield in less than a year.

The mussle culture has the highest potential for production as compared to the culture of any other organisms, such as fin fishes and crustaceans. Further certain bivalve molluscs are expensive and they are luxury food items in Europe and North America. Consequently, interest in mollusc culture is growing rapidly in India.

## 14.8 MUSSEL CULTURE

Mussel culture has been carried out in the open sea off Calicut, in Vizhinjam bay, in Dona Paula bay of Goa, in Ratnagiri and off Madras.

Experimental work on spawning and larval rearing was attempted but hatchery technology has not been developed for mussel seed production. Spawning occurs from May to September and seed mussels are collected from natural beds from October to December for mussel farming along the West Coast. The spat are collected on tiles suspended from rafts. Seed are also collected on ropes made up of either nylon or coir.

The Central Marine Fisheries Research Institute has developed the techniques of floating rafts culture techniques. Green mussel *Perna viridis* seed (20 to 30 mm) are transplanted

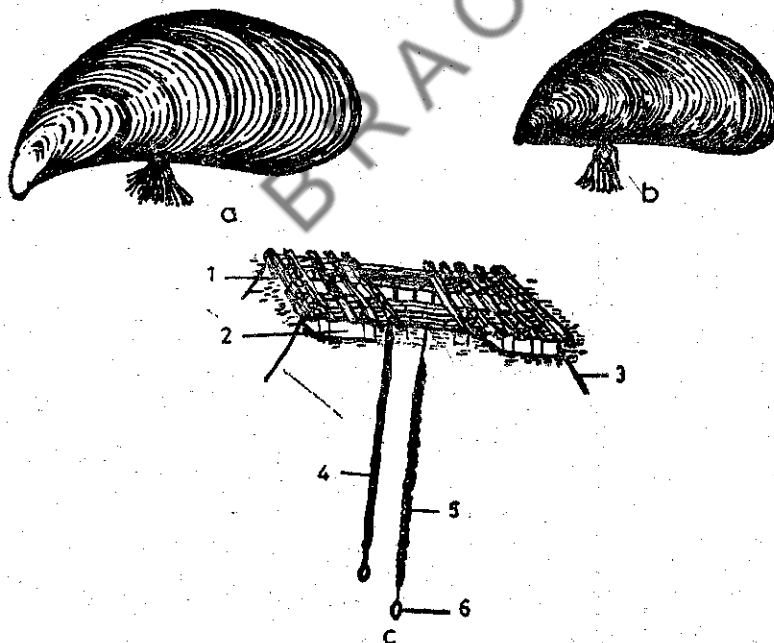

Fig.14.1 Mussels A. Lateral view of the green mussel, *Perna viridis*. B. Lateral view of the brown mussel, *Perna indica*. C. Raft culture of mussels. 1. Bamboo poles frame work of raft. 2. Metal floats. 3. Anchor rope. 4. Newly seeded rope. 5. Seeded mussel rope after 7 to 10 days. 6. Sinker.

Formation of the natural pearl is also influenced by foreign bodies accidentally entering the body of pearl oyster. Tiny particles and organisms enter the oyster when the shells remain open and in certain situations the foreign bodies get trapped between the shell and mantle. Under the stimulus of foreign body, the outer epithelium of the mantle invaginates, forms a pearl-sac and leads to the formation of pearl. Thus every natural pearl characteristically has an inner core or nucleus which may be the disintegrating connective tissue of the mantle or a foreign body.

In the cultured pearl technique, a small piece of mantle from a donor oyster is grafted into the gonad of the recipient oyster together with a nucleus by a skilful surgery. Pearl oyster having a weight of 25 g and above is the ideal size for implementation. Oysters in the immediate post-spawning or recovery phases are selected for pearl production. The oysters are first tranquilised by keeping them for a while in menthol mixed water. Spherical shell beads 2 to 7 mm diameter with smooth finish and highly polished are used as nuclei. The outer epithelium of the mantle piece regenerates itself around the nucleus, eventually resulting in a pearl. Since this pearl is produced in the oyster by surgical manipulation and the seeded oyster is further cultivated, it is called the Cultured pearl.

Sheltered bays are ideal location for pearl oyster farms. They can also be set up in the coastal waters and silting should be minimal. Ambient tropical sea temperature and salinity are suitable for pearl oysters. The mortality rate among the operated oysters is very high about 40 per cent. They die due to either faulty handling during the nucleus implementation, due to disease or because of excess methol in the water.

Raft culture is the typical method of pearl oyster farming in sheltered bays. Mother oyster culture system, and the techniques for hatchery production of pearl oyster have been developed in India.

---

#### 14.12 PROBLEMS AND CONSTRAINS OF BIVALVE CULTURE SYSTEMS

---

Interest in bivalve culture in India is quite recent, and although production oriented techniques have been developed, commercial culture has not begun. Mariculture is a new venture for the country and therefore there is some hesitation on investments for any work in the sea.

The eating of bivalves is popular only in a few pockets along the coast. Even oysters are not widely consumed. There is an urgent need for well Organised nutrition programme for enlarging acceptably.

The sea food processing industry has not taken any serious note of the export potential and efforts have so far been lacking for exploring export markets for the Indian bivalves.

Support to bivalve culture would increase production of animal protein, create employment opportunities and earn foreign exchange through production of high priced commodities. This would also lead to more meaningful diversification in our fisheries and socio-economic improvements in the small-scale fisheries sector.

---

#### 14.13 FISH CULTURE

---

Many species of fishes such as milk fish, perches and eels are suitable for culture and investigation are undertaken by central Marine Fisheries Research Institute. Milk fish *Chanos chanos* cultured in saline ponds gave a production of 857 Kg per hectare. The eel, *Anguilla bicolor* is abundant along the east coast and they breed in the open sea. The elvers ascend the rivers during season. Elvers are collected and are reared in experimental tanks. A suitable method of culturing the eel, *A. bicolor* in running water was developed. This species has given a production rate of 38,000 Kg per hectare at the end of two year period. Cultivated eels have a good export market and are in great demand in countries like Japan.

---

## 14.14 SEA WEED CULTURE

---

Sea weeds which grow along the fringes of sea constitute raw material for producing organic extractives like agar-agar and algin. Agar-agar is a water soluble gel extracted from red sea weeds *Gracilaria* sp, and *Gelidiella* spp. Algin is an alkali soluble gel extracted from brown sea weeds *Sargasum* and *Turbinaria*.

Because of their gelatinous and colloidal nature, both the extractives are used as stabilising, emulsifying, sizing and cementing agents in food, textile, pharmaceutical, paper and bread manufacturing industries. Agar is also used as a medium for the manufacture of synthetic fibre known as sea weed rayon.

Sea weeds form an inexpensive source of minerals, vitamins and trace elements and hence added in dietary rations of cattle, poultry and other farm animals. Sea weeds are used as manure as they contain potassium, magnesium in water soluble form. They improve the water retaining capacity of the soil and control the deficiency diseases of crops.

Major sea weed zones are the coastal regions from Mandapam to Cape Camorin in east coast, Veraval to Okha in west coast. They also occur in the rocky coast of Vizag to Bhimunipatnam, Chilka lake, Bombay and Ratnagiri.

In addition to the exploitation of sea weeds from natural resource, sea weeds are cultivated by adopting various methods viz., 1) Placing boulders or concrete structures in the natural habitats, where useful species grow, 2) using artificial substrata such as coir or synthetic fibre nets in protected areas, 3) transplanting the important varieties to other coastal areas of the country, and 4) through spores.

To study the possibility of culturing desirable sea weeds by vegetative propagation, experiments are being conducted. Fragments of sea weeds are tied to coir net frames and these frames are suspended horizontally in the sea. With in 80 days *Gracilaria* attained harvestable size and 1.25 Kg of plant material of 43.2 Kg (fresh weight).

Attempts are being made to grow economically important species to augment the sea weed resources of our country.

### Check Your Progress

1. Write 5 lines about Rack-and-Tray culture method of Oysters.

---

## 14.15 SUMMARY

---

Brackishwater prawn and fish culture is described here. Brackishwater has a rich fauna. Availability of adequate prawn and fish seed is the prime requisite for the proper development of aquaculture.

Key factors for successful hatchery operations of prawns is discussed here in detail.

Nursery Management is also explained here. Even polyculture system is described here and is found to be economically viable.

Mariculture consisting of Mussels, oysters, clams, Pearl oysters are described in detail. Because the culture of all these bivalves yields lot of revenue for the Government.

---

## 14.16 CHECK YOUR PROGRESS - MODEL ANSWERS

---

1. The rock and tray culture method is employed for Oysters in Tuticorin. Each rack (13.2 x 2 meteres) comprises a series of teak poles. This rack provides a platform for suspending

**oyster cages during the nursery stages or for supporting the oyster trays during the grow-out phase. The oyster cage is 40 x 10 x 10 cm with a lid. It is constructed the same way as the cage except the webbing is 22 mm mesh.**

---

## **14.17 MODEL EXAMINATION QUESTIONS**

---

**I. Answer the following in about 30 lines :**

1. Explain the brackishwater prawn and fish seed availability and collection from natural resources.
2. Write about the penaeid prawn hatchery system.
3. Describe the nursery management of brackishwater prawn and fish seed.
4. Write about the brackishwater stock pond preparation and water management.
5. Give an account of mono and polyculture systems of brackish water prawns and fishes.
6. Write about the mussel culture.
7. Describe the formation of natural pearl and cultured pearl technique.

**II. Answer the following in about 10 lines :**

1. What are the major drawbacks in traditional brackishwater prawn and fish culture?
2. Prawns and fishes suitable for brackishwater farming.
3. Main constituents of brackishwater fish farm.
4. Supplementary feeding in brackishwater prawns and fish culture.
5. Culture of *Anadora granosa*.
6. Sea weeds culture.

---

# UNIT - 15 FISH NUTRITION AND HEALTH MONITORING - NUTRITIONAL REQUIREMENTS AND SUPPLEMENTARY FEEDING

---

## Contents

- 15.1 Objectives
- 15.2 Introduction
- 15.3 Nutritional Requirements
- 15.4 Supplementary Feeding
- 15.5 Summary
- 15.6 Check Your Progress : Model Answers
- 15.7 Model Examination Questions

---

## 15.1 OBJECTIVES

---

This unit deals with the basic nutritional requirements of a fish. The digestibility and utilisation of food items have been discussed. Different types of supplementary feed are given. The factors relating to selection of supplementary feeds and rate of conversion have also been dealt. The methods of preparation and application of supplementary feeds are given in this unit.

---

## 15.2 INTRODUCTION

---

The knowledge relating to basic nutritional requirements of fishes stems from man's endeavors to raise fishes for food and for stocking in lakes and rivers. In intensive fish culture practices the objective is to maintain optimum density of fish per unit area of water by adopting techniques relating to polyculture, multiple stocking, stock manipulation etc. Under such conditions of fish culture, the natural protein component of food organisms present in the environment will not meet the needs of the growing fish biomass, thereby necessitating supplementation with protein rich feeds. Since there is heavy competition of protein foods mainly for human consumption the idea of feeding such type of foods to all cultivated species of fishes does not sound very economic. There are certain foods which are not consumed by the human beings such as plant proteins, condemned grains straw, hay, scrap or human food, by products and wastes from industries, single cell proteins etc. To achieve progressive development of the fish farming industry such substances could be utilised for the preparation of artificial fish feeds after conducting proper experiments.

The development of artificial feeds mainly depend on the studies relating to basic nutrition and physiology. For economic reasons such investigations should aim to find out the minimum level of protein which satisfies the amino acid requirements of the species for optimum inherent capacity for growth, adequate supplementation by carbohydrates to serve as dietary calories and luxurious supply of vitamins and minerals for necessary stimulation of protein digestion.

Information regarding the nutritional requirements of warm water fishes is not available excepting the channel cat fish for which complete ration has been formulated and dietic requirements have

been studied. However, the importance of giving protein rich diets to carps has been realised in view of the high yields obtained. It has been established that the natural food plays only an insignificant role. Results obtained by feeding carps in running and confined water practices, in cages and floats have revealed that carp can grow well even without natural food by feeding with different types of supplementary feeds.

### 15.3 NUTRITIONAL REQUIREMENTS

Carps being the fast growing varieties of fishes are mostly chosen for culture practices in India in fresh waters. The general practice is to provide some starchy foods to these carps to serve as dietary calories. As a result of series of experiments conducted in the country certain balanced artificial feeds have been formulated. To meet the dietary demand of fishes one should know the nutritional requirements of fishes such as proteins, carbohydrates, fats, micronutrients, vitamins etc., besides the knowledge relating to digestibility and utilisation of the compounded feeds by the fish for yielding protein as the final metabolised product in intensive fish culture practices.

**Proteins:** Fishes are efficient converters of vegetable proteins into tasty proteins of high biological value and are able to utilise high levels of dietary proteins for synthesis, as compared to other organisms. It has been reported that at 47°F Chinook salmon require 40% casin, whereas the requirement was 55% and 58°F. It has also been observed that high protein level (53%) is less effective in comparison to lower level (26.67%) when fed to fry and fingerlings of carps. Level of protein depends upon quality of protein for obtaining optimum growth.

Amino acids which are indispensable in human nutrition have been found to be essential for certain fishes and since their composition is known to be the primary factor influencing protein digestion, need for their quantitative requirements by the cultivable fishes could be measured by the qualitative and quantitative distribution of amino acids so that limiting ones can be supplemented by synthetic preparations of complementary proteins resulting in a proper mixture of dietary amino acids for better utilisation of dietary proteins. Composition of amino acids in fish flesh which can offer guide lines for their levels in artificial feeds is given in Table-15.1

Amino Acid	Fish muscle	Fish myosin	Egg	Beef muscle	Cow milk	Chicken muscle
Arginine	7.4	4.8	6.6	7.2	4.2	7.1
Histidine	2.6	2.7	2.4	2.9	2.6	2.3
Lysine	9.0	15.0	7.0	8.1	8.7	8.4
Tyrosine	3.8	2.7	4.5	3.4	6.0	4.3
Tryptophan	1.2	0.9	1.5	1.3	1.5	1.2
Phenyl-alanine	4.4	4.4	6.3	4.9	5.5	4.6
Cystine	1.2	--	2.4	1.3	1.0	1.3
Methionine	3.2	2.3	4.0	3.3	3.2	3.2
Threonine	4.7	5.8	4.3	4.6	4.7	4.7
Leucine	9.5	10.2	9.2	7.7	11.0	-
Isoleucine	6.5	7.7	7.7	6.3	7.5	-
Valine	6.0	6.6	7.2	5.8	7.0	-

Table 15.1. Amino acid composition of Fish and other animal proteins (From the Wealth of India)

#### Animal Proteins

**Fish Meal :** Fish meal is the ideal protein item having all the essential amino acids required in fish feeds. It has been reported that fishes feed with fish meal have yielded better results when compared to the fishes fed with soyabean.

**Silkworm pupae:** In Japan intensive farming of carps in cages and floats is achieved by feeding with silkworm pupae and the conversion rate worked out to 2. It has been revealed that fishes fed on silkworm pupae have yielded better growth when compared to the fishes fed on a mixture of rice bran and mustard oil cake in the ratio 1 : 1. It has been observed that a mixture of animal proteins gave better weight gain and feed conversion than a mixture of plant proteins or any of the proteins tested alone. It has also been reported that plant proteins mixed with 10 to 15% of animal proteins could be utilised as the basic ingredients in formulating the artificial feeds under intensive fish farming.

### **Plant Proteins**

They are deficient in lysine and methionine content, and to avoid amino acid imbalance need supplementation with animal protein. The most favoured items generally used for carp feeding are different oil cakes, and grain fodders. It has been reported that in the composite fish culture of Indian major carps and exotic carps high fish production has been achieved by using a mixture of rice bran and mustard oil cake in the ratio 1 : 1. The nutritive value of oil cakes and grain feeder is dependent on their quality. The quality of prepared feeds will be reduced when their fat content is 10-20%. The overall protein content will be used when the solvent extracted oil cake and rice bran are used as feeds.

**Leaf Proteins :** Information regarding the use of leaf proteins in fish nutrition is, as yet, negligible except for some vegetable eating species, but because of their high production and competitive economy in agricultural industries, they may in the near future occupy a prominent place in fish feeds after adequate processing involving separation of pigments, flavour and toxins.

**Algae proteins:** Algae constitutes the feed of certain varieties of culturable fishes. *Chlorella* spp. have been found to contain all the essential amino acids and protein of desired nutritional and functional quality can be obtained by selecting the suitable media for their culture and adjusting the harvesting time. It has been noticed that feed pellets made of *Chlorella* resulted in the higher yields of *Tilapia mossambica*.

**Single Cell Proteins:** The proteins derived from yeast, bacteria, fungi or algae grown on a variety of substrata, which include hydrocarbons like crude oil, gas oil, natural gas, coal, carbohydrates such as cellulose, grain, sulfite liquor, molasses and organic wastes constitute yet another source of protein. It has been reported that satisfactory results are achieved when yeast is grown on liquid hydrocarbons as a substitute for a part of fish meal.

### **Carbohydrates**

They are diets of starch and serve as a major source of dietary calories in artificial feeds. Most of the cultivable fishes like carps and mullets are omnivorous taking in considerable amount of vegetable matter and are therefore, well adapted physiologically to digest starch. Digestibility of starch is reported to be 30-90%. Rice bran and wheat bran which are the main starchy diets used for cultivable fishes are found to be highly digestible. Potatoes can be used as substitute for grain. It has been reported that the digestibility of potato starch, xylan and algin as 85, 66 and 53% respectively. The ratio of protein to carbohydrate in the feeding of 1 : 7 or 1 : 8 which gives a wide scope to utilise feeding of cheap carbohydrate diets as long as protein in the natural food is sufficient for growth. While formulating the balance diets, carbohydrate and protein ratio needs a careful manipulation so as to spare the proteins for growth and carbohydrate to serve supplying the dietary calories. The diet of certain fishes is said to be nutritionally complete when it contains 39.9% of proteins and 18.2% carbohydrates with food conversion rate of 1.4-2.4:1.

### **Fats**

The fishes cultivated in warm waters utilise the fats in a better way. Stimulation has been noticed in the growth of fishes when cod liver oil is added to the diet. But it is known whether lipids or other components of the oil are responsible for such a type of stimulation of growth. As excess

fats get deposited in liver, trout ration is usually prepared with less than 10% fat content. It has been reported that in order to yield better results of growth and to reduce mortality in rainbow trout fatty acids with Omega-3 configuration between 3-10% are required. The increased fish yield was found mainly due to accumulation of body fat in sorghum fed fish as long as protein was not a limiting factor. Therefore it is clear that provided the protein component in the diet is sufficient, fats can be advantageously used in carp feeds for gaining added yields as well as sparing proteins for growth.

### **Micronutrients**

The growth stimulating micronutrients cannot be substitute for food but their presence in general required to formulate a balanced diet for improving the protein assimilation. In spite of the presence of proteins, growth rate may be slow due to the absence of micronutrients.

### **Vitamins**

Salmon and trout require all the seven vitamins for their growth. Cultivae carps need pyridoxine riboflavin and pantothenic acid. The carps indicated better results when they were fed with 0.8 mg/kg/day of cobalt, which is a part of vitamin B<sub>12</sub> concerned with nitrogen assimilation and synthesis of haemoglobin and muscular protein and addition of 4% fodder yeast. Addition of cobalt chloride increases the survival and growth of cultivable fishes.

### **Antibiotics**

The intensive fish farming results in causing diseases to fishes. The role of antibiotics in stimulating protein metabolism depends upon the quality of diet and best results have been obtained by feeding 20,000 units of terramycin to carps every three days resulting in the growth increase by 9.5% and a fodder saving of 10.5%.

### **Digestibility**

Natural food items of fishes are highly nutritious, reflecting a simple and regular relation between protein, fat, carbohydrate and their utilisation, but in case of artificial feed stuff, elaborate experimental analysis have to be carried out to know their digestibility and utilisation co-efficients. Digestion co- efficiencies are generally measured in terms of nitrogen and calories.

---

## **15.4 SUPPLEMENTARY FEEDING**

---

Culture of a number of compatible non-predatory fish of different but complimentary food habits cultured together to make best use of all the natural food material present in the pond, gives high production. To accelerate fish growth and also to permit increased stocking rate, many kinds of supplementary feeds are used. Supplementary feeds when given to fish are taken directly by them and the left over portion serves as manure, thus indirectly augmenting the production of natural food of fishes.

Supplementary feeds given to different cultivated fishes of diverse feeding habits are:

- 1) Vegetable feeds such as leaves, grasses tubers and roots starches.
- 2) Oil cakes such as mustard, groundnut, til, coconut etc., and other residues.
- 3) Grain fodders like wheat bran, rice, lupine, soyabean, maize, rye, barley etc.
- 4) Feeds of animals origin such as fish flour, fish meal, fresh meat from warm blooded animals blood, poultry eggs shrimps, crabs, mussels, snails etc.,
- 5) Additives such as vitamins and minerals.

Fish may also feed directly on dung applied as manure in ponds.

The selection of supplementary feed depends on number of factors such as:

- 1) Ready acceptability to fish
- 2) Easy digestibility
- 3) High conversion value
- 4) Easy transportability
- 5) Abundant availability

Of all these, ready acceptability by the fish and its conversion ratio and the involved costs are the most important. It should be a balanced one with adequate protein, fat, carbohydrate, mineral and vitamin contents. The rate of food conversion depends on:

- 1) quality of supplementary feed
- 2) stocking density of fish
- 3) size and age of the fish stock
- 4) environmental factors such as temperature, oxygen tension, water etc.
- 5) the method of feeding (the spreading and frequency of distribution etc.)

The preparation of fresh feed of vegetable origin given to fishes is quite simple. According to individual case it is ground, soaked dried or cooked. Oil cake is best given soaked. Oil cakes are very concentrated preferably be soaked for several hours before being given to fishes. Cooking may be necessary to stop the decomposition of certain animal or vegetable materials. In India, supplementary feeding in stocking ponds is of recent origin. In composite fish culture oil cakes such as mustard oil cake and rice bran or wheat bran in 1:1 ratio by weight is given to the stocked fishes at the rate of 1-2% of the body weight daily, depending on the consumption of the feed by the fishes. Aquatic weeds, are given to grass carp in as much quality as it can consume. Supplementary feeding should be stopped when tick algal blooms develop in the pond or when oxygen depletion occurs.

In recent years in pond fish culture, many sophisticated devices of feeding of fish have been developed. Ordinarily feeds are not to be spread all over the pond surface, but are broadcasted in particular spots of the pond or kept in trays in the form of dough and hung in the pond at 3-4 places. The feeding spots should be periodically inspected and changed so that no sustained putrefaction occurs at the spots of feeding. Vegetable matters such as aquatic weeds, leaves and grasses for feeding grass carp are best given in floating bamboo rectangle frames kept in position by stacks fixed in the pond bottom. The device prevents any leafy feed from drifting above the pond. Feeding should preferably be done in the morning hours since the process of digestion requires more oxygen for increased metabolic activity of the fish. The increased requirement of oxygen can be met during the day when the oxygen contents of the pond is always higher.

In tropical countries, feeding is done throughout the year while in temperate countries the rate and amount of feed given is reduced when temperature falls during winter.

#### Check Your Progress

1. Fishes are efficient converters of \_\_\_\_\_ proteins into tasty proteins of high biological value.
2. Fish meal is the ideal protein having all the essential \_\_\_\_\_.

---

### 15.5 SUMMARY

---

The nutritional requirements of the fish are described here. Different types of supplementary feeds are given here.

---

## 15.6 CHECK YOUR PROGRESS - MODEL ANSWERS

---

1. Vegetable
  2. Amino Acids
- 

## 15.7 MODEL EXAMINATION QUESTIONS

---

### I. Answer the following in about 30 lines :

1. How does the development of artificial feeds mainly depend on the knowledge about the basic nutritional requirements of a fish?
2. Write about the protein requirement in a fish?
3. What are the different types of supplementary feeds given to fishes? What are the factors depending on which the supplementary feeds are selected?
4. What are the factors on which the rate of conversion depends? Write about the conversion ratio of some of the feeds?
5. What are the different methods of preparation and application of supplementary feed?

### II. Answer the following in about 10 lines :

1. Carbohydrates
2. Fats
3. Types of supplementary feeds
4. Factors for selection of supplementary feeds
5. Methods of application of supplementary feeds

BRAOU

---

# UNIT - 16 FISH DISEASES - CAUSES, SYMPTOMS AND CONTROL

---

## Contents

- 16.1 Objectives
- 16.2 Introduction
- 16.3 Types of Fish Diseases
  - 16.3.1 Bacterial and Viral Diseases
  - 16.3.2 Fungal Diseases
  - 16.3.3 Diseases Caused by Protozoa
  - 16.3.4 Diseases Caused by Worms
  - 16.3.5 Diseases Caused by Dectylogyrus, the Gill Flake.
  - 16.3.6 Diseases Caused by Crustaceans
  - 16.3.7 Environmental Diseases
  - 16.3.8 Nutritional Diseases
- 16.4 Summary
- 16.5 Check Your Progress - Model Answers
- 16.6 Model Examination Questions

---

## 16.1 OBJECTIVES

---

In this unit the different types of fish diseases that are commonly encountered especially in an aquaculture system and the main reasons for fish diseases are discussed. The parasites causing the diseases, the symptoms and the treatment of the diseases are also given.

---

## 16.2 INTRODUCTION

---

Types of diseases - infectious diseases and non-infectious diseases. Parasites may be facultative or obligatory. Conditions suitable for successful transmission of diseases - stress conditions. Bacterial and viral diseases : Causes, signs and treatment. Fungal diseases-causes, signs and treatment. Diseases caused by Protozoa : causes, signs and treatment. Diseases caused by worms : Causes, signs, and treatment. Diseases caused by Crustaceans : Causes, signs and precautionary measures. Nutritional Diseases : Causes, signs and precautionary measures.

---

## 16.3 TYPES OF FISH DISEASES

---

Diseases may be classified as infectious diseases when they are caused by microorganisms such as protozoa, bacteria, fungi or viruses. Diseases not caused by microorganisms are non-infectious diseases which include nutritional deficiencies, intoxications or low oxygen levels.

Parasites may be facultative or obligate. Facultative parasites are free living in nature but may, under certain circumstances, begin to parasitize fish. Good examples of facultative parasites are the carnivorous protozoan *Tetrahymena pyriformis* and the stalked protozoan *Epistylis*. Both of these parasites may be free living in nature—usually in water high in organic pollution and can transfer to fish when significant damage can result. Obligate parasites are those which require presence of the host for reproduction. Examples are *Ichthyophthirius multifiliis*, *Costia* and monogenetic trematodes.

Successful transmission of a disease requires the presence of a sufficient number of susceptible fish per unit volume of water and the presence of the organism in sufficient numbers. Frequently adverse environmental factors (stressors) are required to initiate a disease. Overcrowding of fish increases the likelihood of an initial contact between a parasite and a fish and also ensures that the parasite will spread rapidly among a group of fish. It does not take long before an introduced parasite can multiply to tremendous numbers on individual fish.

Stress plays an important role in the transmission of many bacterial diseases and external protozoan diseases. The basic mechanism of how fishes lose their natural resistance to bacteria after some stressful condition is that hormonal imbalances result, in a decreased efficiency of the natural ability of the fish to ward off the ever present bacteria in water.

The specific disease defence system of an animal is the immune system. The decreased efficiency of the immune system involves a combination of factors : a decrease in the effectiveness of the white blood cells of the fish phagocytize bacteria; and a decrease in the production of antibodies (specific proteins found in the blood which assist white blood cells in destroying bacteria). A commonly used diagram to emphasise and stress is presented in Fig. 16.1, which suggests that many fish can function as long as environmental stresses are minimized or not present.

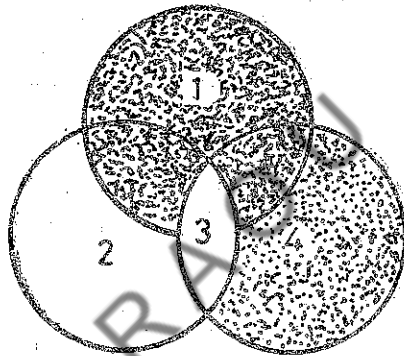

Fig 16.1 The figure illustrates the interdependence of host, parasite and environmental stress factors in a disease process. 1. Fish 2. Parasite 3. Disease 4. Environment

Good water quality is the key to successful fish production. An abundant water supply will solve many problems associated with intensive fish culture by diluting out accumulated wastes and toxic products as well as maintaining optimal water conditions. Insufficient dietary proteins will eventually lead to reduced growth rate, poor reproduction and increased susceptibility to infectious diseases. Dietary toxins can be found in fish foods. In general such toxins can come from microorganisms which contaminate feed, degradation of raw material used to formulate diets, or breakdown of dietary ingredients during storage.

#### 16.3.1 BACTERIAL AND VIRAL DISEASES :

1. **Infectious abdominal dropsy of carp :** This is currently the most feared disease in carp culture. The bacterium *Aeromonas (Pseudomonas) punctata* is the primary cause of the disease. The physical condition of the fish and of the environment are involved in the appearance and evolution of this disease which brings severe physiological problems with it.

According to its exterior characteristics, two forms of infectious abdominal dropsy can be recognized ; one is intestinal and the other ulcerative. The intestinal form is characterized by the swelling of the belly caused by the accumulation of a yellow or pink coloured liquid in the body cavity. The ulcerative form manifests itself by bloody areas as the body where the muscles can be seriously affected. The fins are sometimes partially destroyed.

#### Treatment

(a) **Preventive measures** :Prophylactic measures help to diminish the mortality rate considerably. Everything which might weaken the fish must be avoided such as long storage, unnecessary handling and lack of natural food. When the disease presents itself the dead fish must be removed carefully and then destroyed. After emptying, the pond should be left dry and disinfected with quicklime. Stocking should also be in ponds which have been well prepared with fertilizers and in which natural food has had time to develop. Artificial food of good quality can be distributed, early in the season in order to allow the fish to get over this most critical period, with less danger. Fish of different origin should not be mixed and on each farm an effort should be made to obtain by means of selection, fish which are able to resist dropsy.

(b) **Curative measures** :If the fish are diseased when they are stocked or if there is a danger of infection, antibiotics can be used-injected or mixed with food. Chloramphenicol is effective against *Acromonas punctata*. If the infection is due to other similar bacteria, oxytetracycline and at a ratio of 1 to 1.5 mg. of chloramphenicol for each 100 gm. of fish body weight. The necessary quantity of chloramphenicol is dissolved in from 1 to 2 ml. of water. Antibiotics can also be mixed with food in such a way that fish weighting 100 gm will absorb 1 mg per day. This method is advised for the ulcerative form of infectious abdominal dropsy.

#### Viral haemorrhage septicaemia (VHS)

It is a viral disease. When latent, the disease is difficult to discover. It can become chronic, suddenly, among apparently healthy fish and a high mortality rate will follow, when the environment is altered or the fishes handled. It can last for months in its chronic form and the growth of the fish will be small. As with most viral diseases, at one time one organ and at another time another is attacked though most often the kidneys and liver are affected. The first sign is apathy - the fish move about very little and rest on the surface close to the banks. When they swim, their movement is sharp and disordered and their position in the water is abnormal. They develop exophthalmos (swollen eyes), anaemia characterized by a reduced haemoglobin rate and pale gills which turn pale grey immediately after death. The belly swells and a foul smelling yellowish liquid is found in the body cavity. The anus protrudes and there are slight haemorrhages in the muscles and on the swim bladder. The intestine turns red and is inflamed; muscular oedema may be present. The fins fray and there are sores on the skin.

**Treatment** :Currently there is no effective treatment of the VHS disease. The deceased fish should be isolated and dead or seriously affected ones should be removed. The ponds should be disinfected and sufficient water supply should be provided. High stocking densities and over feeding should be avoided. The food given should not be too fatty but should be rich in vitamins and proteins. If the disease is chronic, feeding must be temporarily stopped and then followed by the progressive distribution of light and varied food.

#### Infectious pancreatic necrosis (IPN)

This virus brings sudden and widespread death to young fish at the start of artificial feeding.

**Signs** : Affected fish revolve on their longitudinal axis, swim around rapidly and in a disordered fashion and then become immobilized near the banks or on the bottom of the pond. The eye

will be protruded. A viscous whitish liquid accumulates in the stomach and intestine. The liver and the spleen are pale and the gall bladder shows severe necrosis.

**Treatment:** There is no known method of treating this highly contagious disease effectively.

### **Furunculosis**

Furunculosis is a bacterial disease caused by *Acromonas*. The infection is transmitted through the digestive tract or through small wounds on the skin. The bacteria breed abundantly in the blood, the liver, the spleen and the kidneys. This disease can kill fish rapidly on a large scale.

**Signs:** Bloody boils of various sizes appear on the skin. Small lumps also appear under the skin. The disease is frequent in dirty water which contains organic matter.

**Treatment:** Infected ponds must be isolated and the dead fish carefully removed and destroyed. After emptying, the ponds should be disinfected with quicklime or calcium cyanamide. Handling and sudden changes of the environmental condition should be avoided if the disease in its latent form is suspected. If there is a danger of infection, fish must be raised in ponds fed with very pure water and in which the temperature is not too high and the amount of dissolved oxygen constantly high.

Furunculosis can be treated by mixing sulphonamides, nitrofurans and antibiotics with the food. These must be administered as soon as the disease is noticed.

## **16.3.2 Fungal Diseases**

### **Saprolegnia infection**

Water mould or *saprolegnia* infection is caused by fungi of the genera *Saprolegnia* and *Achlya* which develop in injured, weakened, diseased or dead fish. These fungi are present in water rich in organic matter which they find a favourable medium for development. Parasitic fungi live as saprophytes on the remains of food and the bodies of dead fish. *Saprolegnia* can effect all species of fish in all environments and at all ages. Particularly all external lesions open the way for the parasitic fungus.

**Signs:** Infection is characterized by woolly, grey white or lightly brown blotches on the skin, fins, eyes, mouth or gills. Affected eggs are completely covered by fungus, including dead eggs and neighbouring healthy eggs which are stuck together.

**Treatment:** The following should be avoided: injuries, long storage in cement tanks, brutal handling, diseases, weakness, unhealthy surrounding, bad quality water or too high stocking. The infected fish are treated by one of the following baths: Potassium permanganate 1 gm per 100 litres of water for between 60 to 90 minutes; salt baths, 10 gms per litre of water during 20 minutes for young fish, copper sulphate bath; 5 gm in 10 litres of water in a wooden vat; a malachite green (Zinc free) bath prepared from a stock solution of 1 gm of malachite green in 450 ml of water. Malachite green can also be used for treating small ponds: 1 gm of malachite green for 5 to 10m<sup>3</sup> of water.

### **Gill rot or branchiomycosis**

Fungi of the genus *Branchiomyces* cause the gills to rot in most Cyprinids. The disease manifests itself principally in the summer in densely stocked ponds, rich in organic matter and with abundant phytoplankton.

**Signs:** At the start the fish have pale gills showing deep red coloured patches. Finally the gills are partially destroyed, turn a yellow brown colour and are attacked by *Saprolegnia*. In warm weather the development of the disease can be rapid.

**Treatment:** Too dense stocking and when the weather is warm, a water supply too rich in organic matter should be avoided. When the weather is very hot it is necessary to reduce artificial feeding and provide good supply of freshwater. When the disease is present, 200 Kg of finely ground quicklime should be spread per hectare taking care that the pH does not exceed 9.0. As a preventive, an algicide (Copper sulphate, or Benzalkonium chloride) should be used. The dosage is 8 Kg of copper sulphate per hectare for ponds with an average depth of 1 metre. Benzalkonium chloride may be used as a 1 hour bath containing 1 to 4 ppm of active ingredient. A copper sulphate bath of 1 gm in 10 litres of water for from 10 to 30 minutes will kill the parasites.

### 16.3.3 Diseases Caused by Protozoa

Numerous protozoan parasites live on the bodies of the fish. They attack the skin, both on the surface and underneath, the gills, muscle fibres and cartilaginous tissues etc.

#### Costiasis

Costiasis is a common disease which can attack all species of fish from the earliest age. This disease is often noticed when the fish are too densely packed in the rearing troughs and in holding ponds and tanks. Lack of food or excess acidity of water also will cause it. The disease is caused by the flagellate *Costia necatrix* measuring from 10 to 20th thousands of a millimetre. They live in large numbers on the skin, the fins and the gills. They should be considered especially as a parasite favoured by debility.

**Signs :** The skin of the affected fish is covered with a light grey blue film, while those parts which are seriously affected can show red patches. Affected gills turn brown and can be partially destroyed. The fish weaken and lose their appetite.

**Treatment :** Baths can be used to treat costiasis after which the infected fish must be placed on ponds rich in food but they must not be too densely stocked. Formalin baths are effective: 20 to 25 ml. of formalin in 100 litres of water over a period of from 30 to 45 minutes. For fry and small carp salt baths are given. 10 gm. of salt per litre of water for 20 minutes. The doses can be doubled for large fish and the bath should then take from 10 to 15 minutes.

#### Myxosporidians

Myxosporidians constitute typical fish parasites known to produce cysts on different regions of the body and internal tissues and organs. The common myxosporidian genera are: *Leptotheca*, *Chloromyxum*, *Myxobolus Henneguya*, *Thelohaxellus*, *Myxidium*, *Lentospora*.

**Signs :** Weakness, emaciation, raising of the scales along their posterior margins, falling of scales, loss of chromatophores, perforation of scales, etc. Myxosporidian infections have been commonly observed in Indian carps in waters having less than 400 ppm chloride content.

**Treatment :** Affected fish should be disinfected with candys fluid or a weak solution of sodium chloride. Myxosporidian infections, encountered in over stocked ponds, are controlled by thinning the population and using yeast pellets at 1 g 1 Kg of feed.

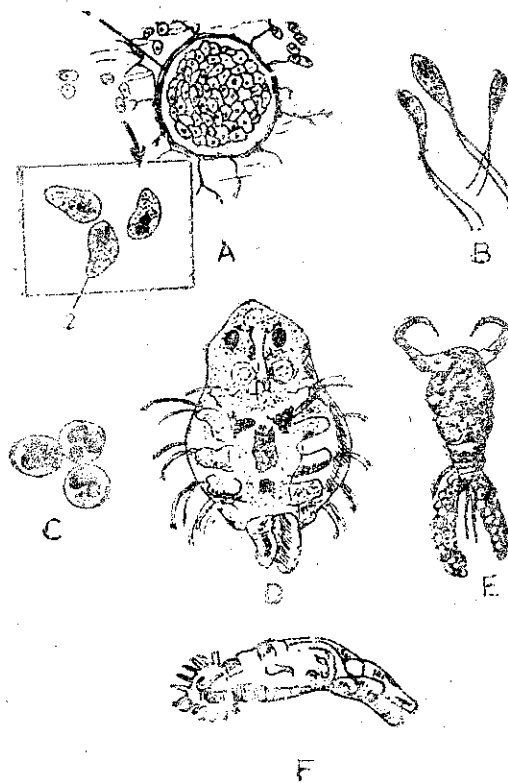

Fig.16.2 A.Plistophora B.Spores ofHenneghya C.Spores of Myxosoma D.Argulus  
E.Ergasilus F.Monogenetic trematode 1. Pansporoblast 2. Free spores

### Ichthyophthiriasis

*Ichthyophthirius multifiliis* is a ciliated protozoan which affects the skin and the gills of most fish species of all age classes. The young parasites are very small and are very often found in the water seeking a host. If they meet a fish they attach themselves between the dermis and the epidermis. They raise the epidermal cells and grown rapidly until they are about 1 mm. in size and are visible to the naked eye. When they reach full size they leave the host fall to the bottom, encyst and then multiply by a celluar division, liberating swarms of young parasites which start looking for hosts.

**Signs :** Small white species are noticeable on the skin and when the attack is serious these can change into white spots. The gills also can be attacked. The fish jump in the water and try to rid themselves of the parasites by rubbing themselves up against the bottom or against any submerged object.

**Treatment :**The infected fish should be changed from one pond to another every 2 or 4 days. As *ichthyophthirius* cannot live without hosts they die after a few days in ponds which are not stocked. All fish carrying parasites must be eliminated. 1 gm. of malachite green for 10 m<sup>2</sup> of water every two days will cure the infected fish. Spreading of ponds with 3 tons of quicklime per hectare in two distributions with an interval of 2 days of gap destroyed the parasites. Quinine baths (1 gm. for 20 litres of water), chloramine bath (1 gm for 100 litres of water), tryptoflavine bath (1 gm for 100 litres of water) are recommended for controlling the disease. During this

operation the water must be well aerated. Repeated formalin, FMA (Pyridylmercuric acetate) and of common salt baths are also recommended.

### 16.3.4 DISEASES CAUSED BY WORMS

#### Disease caused by fish leeches

The blood sucking leach (*Piscicola geometra*) is a very common external parasite found especially in calm water. It attacks all species of fish in ponds. The blood sucking leach is a cylindrical, ringed worm about 2 or 3 cm in length and 1 mm in diameter. It has a sucker at each end of the body of the fish where it sucks the blood. When it has had its fill, it detaches itself from the fish and swims freely in the water with an undulating movement.

**Signs:** The affected fish may be almost covered with these parasites. They look poor and are weakened through loss of blood. The incisions make it possible for them to be affected by other parasites and diseases such as fungus.

**Treatment:** If the parasites are too many the pond must be emptied and the fish bathed. Lysol (a mixture of 50 percent cresol and 50% soap) bath (1 c.c of Lysol for 5 to 15 seconds) followed by rinsing in freshwater. A salt bath, with 10 gms. of salt for litre of water, for 20 minutes, is also effective. Lime bath consisting of 2 gms of quicklime per litre of water, for 5 seconds is also recommended. After drying out of the pond the bottom must be treated with quicklime in order to destroy the eggs and the leeches still living there.

#### Ligulosis

This is caused by a long ribbon like tape worm, *Ligula intestinalis*. In fish culture the disease can be prevented by eliminating water fowl.

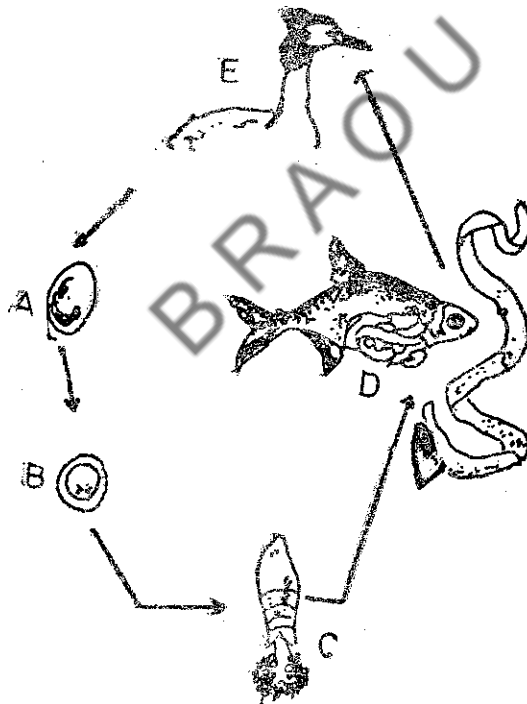

Fig 16.3 Life cycle of *Ligula intestinalis*.

- A. Egg    B. Ciliated larvae    C. Proceroid larvae in the body of copepod    D. Tape worm in the body of fish.    E. Sex ripe worm in the intestine of a bird.

### Disease caused by *Dactylogyus*, the gill fluke

*Dactylogyus* is a small flat trematode worm which attacks the gills of fish. This parasite is a great danger to young fish, especially if the fish is not in good condition and the attack is severe.

**Signs:** It is in the summer that the parasite is found in first carp nursing ponds. The gills swell and turn grey at the edges. Afterwards they will be partially destroyed.

**Treatment:** Fish suffering from *Dactylogyus* infection can be treated with baths: salt baths at the ratio of 25 gms. per litre of water during 10 minutes for large fish and 15 gms per litre during 20 minutes for water for 30 minutes for fry and 1 ml. per litre of water over 15 minutes for large fish.

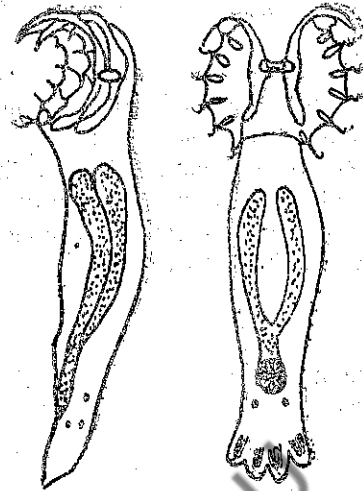

Fig 16.4 Ventral and Lateral view of *Dactylogyus*

### Diseases caused by blood fluke, *Sanguinicola*

*Sanguinicola* live as an adult worm in the blood system of the fish particularly in the bulbus aortae and the blood vessels of the gills. The eggs enter the blood stream and increase in size during their migration. They are distributed to all organs of fish. The ciliated larva (miracidium) bores its way out of the eggs situated in the gills and attacks a snail (*Limnaea* etc), which is used as intermediate host. A sporocyst containing radiate and cercariae forms in the liver of the snail. As they glide in the water over the gills the free swimming cercariae try to penetrate into the fish again through the gills or the skin, and in doing so lose their forked tails. The parasite develops into a sexually mature fluke in the blood system of the fish. Most of the damage to the fish is caused by the eggs. There are blockages in the blood vessels of the gills and thrombosis develop. When mature the mature the adult also try to penetrate into the gills and also cause blockages in the vessels and consequent loss of respiratory surfaces. During the egg laying period 95% of the adult *sanguinicolae* are found in the blood vessels of the gills. Early stages of carp attacked by *sanguinicolae* are there fore usually severely injured or killed by the massive presence of eggs in the gills by blockages in the gills and by the development of thromboses.

**Signs:** The fish hardly move and keep near the banks and inlets and generally show a feeble reaction to their environment. The gills produce a lot of mucous and the gill filaments become necrotic, thus making oxygen absorption impossible. Small fish can be killed by the massive penetration of cercariae. Growth of the fish suffers.

**Therapy :** The cycle of development of the parasites can be interrupted by destroying the snails, i. e. the intermediate hosts. The snails can be destroyed by quicklime (50 tons per hectares) or chloride of lime (6-10 tons per hectare) or by adding 7 gm. copper sulphate or copper dichloride or copper acetate to 10 m<sup>3</sup> water.

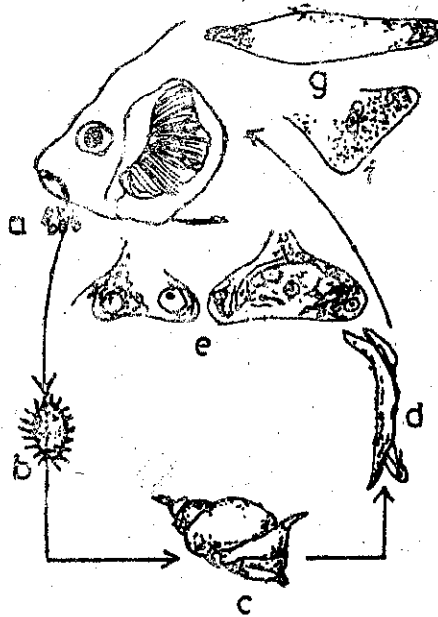

Fig. 16.5 Cycle of development of *Sanguinicola*

- a. Eggs    b. Ciliated larva    c. Snail (Intermediate host)    d. *Cercaria cristata*  
 e. Sexually mature *Sanguinicola*    f. *Sanguinicola* eggs in the gills  
 g. Degenerated eggs of *Sanguinicola* clotted together in the kidney.

#### Diseases caused by Acanthocephalans

Acanthocephalans, also called thorny headed worms, are characterised by a proboscis with hooks at the front end of a bulb shaped body. Adult forms are found in the intestine of fish where the "nose" is embedded in the intestinal lining of the fish. Heavy infestations can cause intestinal blockage. The life cycle of many acanthocephalans is completed when larvae of copepods ingest the eggs. The cycle is completed when a fish eats the insect. Fish may form the intermediate host for a larger vertebrate such as birds or mammals. In this case, cysts containing larval stages of acanthocephalans may be found in the abdominal cavity of the fish.

**Signs :** Emaciation is common in heavily infected fish. Diagnosis is by examination of intestines and identification of the characteristic spiny proboscis.

**Control and Treatment:** Since insect larval forms are the intermediate forms, this type of feed should be avoided.

#### DISEASES CAUSED BY CRUSTACEANS

##### *Argulus*

*Argulus* spp. or fish lice, are common parasites which attack fish. *Argulus* is small, flat crustacean, green yellow in colour and up to 8 mm. in length. They attach themselves to the skin of the

fished, especially at the base of the fins, by means of hooks and two suckers situated under the eyes. Between their antennae there is a kind of sharp pointed dart situated in front of the mouth which is shaped like a horn. The sting can cause wounds which open the way for other infections. In extreme cases the wound inflicted and the resulting anaemia can cause death.

**Signs :** The sting of fish lice causes red blotches on the skin. The fish show signs of nervousness and scratch themselves to get rid of the arglids.

**Treatment :** Treatment includes baths : Lysol baths as for leeches. Potassium permanganate : 1 gm in 1 litre of water during 40 seconds. Preventive measure consists of drying of ponds followed by liming with quicklime.

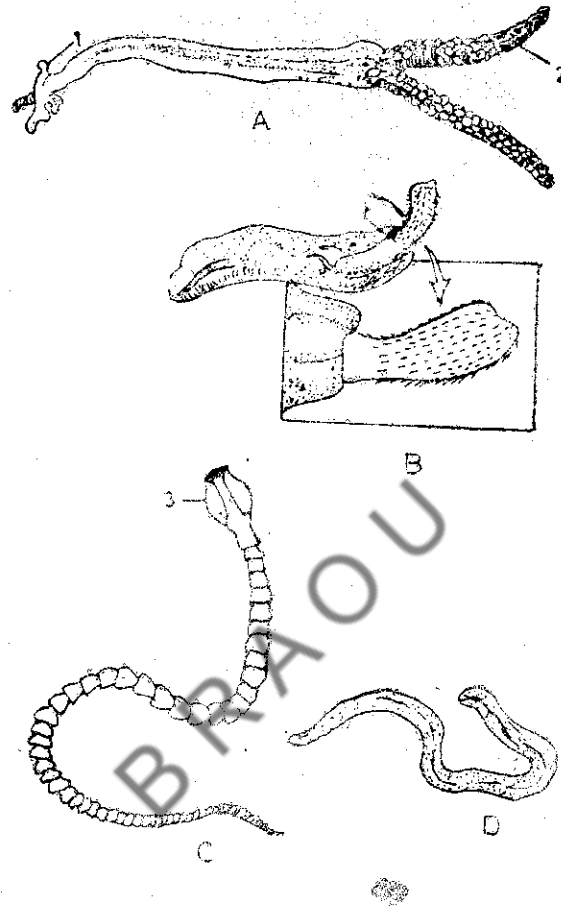

Fig. 16.6. A. *Lernaea* B. *Acanthocephalan* (Thorny headed worm) C. Tape worm D. Nematode (Round worm)

### **Lernaea**

It is also called anchor parasite. Inflamed areas accompany the site of attachment and a secondary bacterial or fungal infection frequently develops. *Lernaea* are firmly attached to their hosts. After juvenile forms penetrate the host, the appendages of the head become so modified that the parasite resembles an anchor at its anterior end. These branching protrusion prevent release of the parasite. The parasite frequently is a primary factor in lethal bacterial infections.

### **Ergasilus**

It is a parasitic copepod which attacks the gills of various fish. The second antennae are enlarged, terminating in large claws which serve as a means of attachment. The parasites feed on blood and body fluids. Secondary infections in the wounds thus caused are common.

### 16.3.9 ENVIRONMENTAL DISEASES

**Too acid Water :** If the pH falls below 5.5 the water can, little by little become toxic for most of the fish in the pond. From a pH equal to 5.0, mortality can start. The skin of the fish will be covered with a whitish film and secrete a lot of mucous : the edges of the gills will turn brownish. If at the same time, the water is ferruginous the colloidal iron will settle on the gills and make breathing difficult thus increasing the harmful effects of the acidity of the water.

If pH falls to 5.5, 500 kg. of calcium carbonate should be spread per hectare.

**Too Alkaline Water :** A pH above 9.0 should be considered dangerous for the fish. This can be caused by pollution or too strong an assimilation of an abundant submerged vegetation in bright sunshine. The gills of the fish will be burned and their fins injured.

**Leak of Oxygen :** The dissolved oxygen content depends on the pond water temperature linked with it. It also depends to a considerable degree on the quantity of organic matter present and the submerged aquatic vegetation. Neither should be too great. Sprinkling of water by mechanical means increases the oxygen content of water.

### 16.3.10 Nutritional Diseases

Artificial feeding plays an important part on many forms especially those which raise fish intensively. Over feeding is often the cause of disease and death.

'**Lipoid hepatic degeneration**' is essentially a nutritional disease of which many symptoms are identical with 'viral haemorrhagic septicaemia'. It is characterized by a yellow-brown colour of the liver. Treatment includes avoiding overfeeding, letting the fish go without food from time to time and the periodical distribution of fresh food.

**Enteritis** is also a feeding disease. If the abdomen is pressed slightly a yellow red liquid will flow from the anus. An examination of living or moribund fish shows red, congested and severely inflamed intestines. This inflammation is caused by feeding errors.

**Hepatoma** which shows itself on the body as an external hard tumour behind the pectoral fins is believed also to be due to feeding and has been shown to be caused by aflatoxin.

**Treatment :** Food must be distributed in good condition and even dry concentrates should not be stocked or distributed, in too large quantities, at one time. Food must be rich in vitamins, not too fatty or too salty (not more than 2% salt) and should include sufficient fillers. In general the daily ration should not be more than 2.5% of the weight of the fish. Feeding should be reduced or even stopped when the weather is too hot or too cold. One ration should preferably be divided up and fed twice or even more. This is better than a single feeding. The intestine and the liver of the fish should be examined from time to time and if there are any doubts feeding should be suspended for several days and then started gradually. The fish should go without food one day per week and from time to time dry concentrates should be replaced by fresh food.

### Check Your Progress

1. One bacterium \_\_\_\_\_ causes Infectious abdominal dropsy of carps
2. \_\_\_\_\_ is a ciliated protozoan which affects the skin and gills of the most of the fishes.

---

## 16.4 SUMMARY

---

Various types of fish diseases are discussed here. The fish diseases may be caused due to bacteria, viruses, fungi or protozoa. The infective abdominal dropsy is a most feared disease in carps and its causes and remedies are given here. Viral haemorrhagic septicaemia is another disease which attacks liver or kidneys of fishes. Various types of fungal diseases such as saprolegnia is also described here. Gill rot is another harmful disease of fishes is also described here. Several other diseases caused by protozoans, worms are also discussed in detail.

---

## 16.5 CHECK YOUR PROGRESS - MODEL ANSWERS

---

1. *Acromonas punctata*
2. Ichthyophthirius

---

## 16.6 MODEL EXAMINATION QUESTIONS

---

I. Answer the following in about 30 lines:

1. Give an account of common bacterial and viral diseases encountered in the fishes and their treatment.
2. Give an account of common diseases caused by protozoans in the fishes and the symptoms and treatment of the diseases.
3. Give an account of the diseases caused by crustaceans and their treatment.
4. Describe the diseases caused by worms in fishes and their treatment.
5. What are the environmental diseases, their causes and precautionary measures to be taken?
6. Describe the conditions suitable for acquiring diseases in fishes and the remedial measures to be taken.

II. Answer the following in about 10 lines:

1. Infectious diseases
2. Non-infectious diseases
3. Saprolegnia diseases, signs and treatment
4. Nutritional diseases
5. Disease defence system in fishes
6. Gill rot disease and treatment.

# UNIT-17 FISHERY TECHNOLOGY - PRESERVATION, PROCESSING AND TRANSPORTATION

## Contents

### 17.1 Objectives

### 17.2 Introduction

### 17.3 Methods of Preservational Processing

#### 17.3.1 Refrigeration and Freezing

#### 17.3.2 Pretreatment of raw material before canning

#### 17.3.3 Cans

#### 17.3.4 Methods of Canning

### 17.4 Transportation of Fish

### 17.5 Summary

### 17.6 Check Your Progress - Model Answers

### 17.7 Model Examination Questions

## 17.1 OBJECTIVES

This unit deals with the general principles of fish preservation to keep up the nutritional quality of the diet. The fish gets spoiled on storage and the type of spoilage depends on various factors involved in conditions of storage. The various preservation and processing methods to prevent such spoilage are dealt with. Further this lesson deals with the improved containers for short or long distance transportation which improve the quality of the preserved fish products and to solve the malnutrition of our country.

## 17.2 INTRODUCTION

The consumer when he purchases the fish shall look for certain characteristics like quality, freshness of fish, degree of spoilage, damage, deterioration during processing, storage, hazards to health, aesthetic consideration and above all satisfaction on buying and eating.

A fresh fish will have a shining with transparent, uniformly spread slime. The eyes are protruding, bright with a jet black pupil and transparent cornea. The gills are generally bright red and free from visible slime. The flesh of a fresh fish should be firm. Finger prints should not be left on the skin surface when fish is handled. The vent should not be protruding. The odour of the flesh is generally known as "marine" "fresh sea weedy" or "laky" for freshwater fish.

The newly caught fish generally contain feed in their digestive tracts. Soon after the catch the gut should be removed to avoid powerful digestive enzymal attack causing discoloration called "belly burn" or disruption called "bellies" or "belly burst". When cooked fresh fish exhibit delicate a pleasant odours and flavours.

Soon after death glycogen in the muscles is converted into lactic acid and the body stiffens and "rigor mortis" sets in when the flesh becomes hard, firm and does not yield juice under pressure. The fish becomes putrid, the surface loses its bright shine and color and becomes covered with thicker slime which grows increasingly turbid finally resulting in yellow or brown colour. The eyes gradually sink and shrink, pupil becoming cloudy and milky, and cornea opaque. The gills assume light pink colour turning to greyish brown covered with thick slime. The flesh gradually softens exuding juice under slight pressure and become dull and milky in appearance. In a spoiled fish gradual change in odour of the raw fish appears initially it is fresh, becomes sweetish, fruity, later ammoniacal or fishy odour dominate until putrefication odour becomes evident. The pH in a spoiled fish may exceed 7.6 compared to 6.4 for fresh fish.

Thus the marketing of fish becomes an important factor since the fish is subject to spoilage where quality is reduced below an acceptable level.

### Spoilage

The fish after its landing is subjected to a variety of deterioration which are due to three main factors. They are (1) bacteria, (2) digestive enzymes and (3) oxidation or autolytic (oxidation leading to rancidity). These factors vary with the species of fishes depending on the amount of oil in the flesh. During rigor mortis, bacterial action is greatly retarded. However enzymes of tissues and viscera continue to function and cause softening of the flesh for bacterial decomposition and a general breakdown of nitrogenous components. Oxidation causes rancidity and appearance of brown coloration in oily fishes such as oil sardine, mackerel, catla and other freshwater fishes. Fish spoiling microflora is found in the external slime. Bacterial, autolytic and chemical changes continue at a slow rate even after the rigor mortis subsided. Ammonia, CO<sub>2</sub>, amino acids and other volatile basic compounds are formed on account of splitting up of proteins and other nitrogenous matter. Hydrogen sulphide and indole are produced as end products with foul smelling. Bacterial spoilage results in the formation of trimethylamine the concentration of which provides an index of the spoilage of marine fishes. The spoilage can be controlled through proper application of low temperature, chemical preservatives, ionising radiation, elimination of moisture and avoiding physical damage etc.

Before preservation, the slime, blood stains, faeces and foreign matter are washed with clean water. The gut is removed and the body cavity is washed in large fishes. Refrigeration and freezing, drying, salting, smoking, canning etc., are the different methods of preserving the fish. The product obtained by drying, salting and smoking is known as the cured fish. The basic idea of preservation is to prevent the spoilage and make the food available at future time or at distant locations.

---

## 17.3 METHODS OF PRESERVATION AND PROCESSING

---

### 17.3.1 Refrigeration and freezing

Freezing means removal of heat from a body. To check the enzymal, bacterial action and putrefaction it is preferred to store the fish under lower temperatures. The fishes are chilled in ice when they are to be stored for a few days. Ice is put inside the body cavity in large fishes. The fishes are arranged in tiers in shelves or boxes and stacked and should not be dumped in heaps in cold storage. It is preferred to store at a temperature below 6.6 °C to prevent microbial spoilage of fish. The formation of ice to some extent causes damage to the biological material like growth of crystals of ice ruptures the structural components thus releases the enzymes and precipitation of liquid water may cause precipitation of proteins effecting the change of pH making it more or less dry.

The ice formation is initiated when the temperature of fish is lowered to about -1°C with a change in the concentration of inorganic and organic compounds. Freezing continues to fall

with the lowering of temperature. At  $-50^{\circ}\text{C}$  to  $60^{\circ}\text{C}$  the entire water in the fish is frozen. The maximum, freezing of water is between  $1^{\circ}\text{C}$  and  $5^{\circ}\text{C}$  with different sized crystal formation of ice. Ice formation occurs at a place where heat is extracted and then to spreads warmer area from where heat is conducted to refrigerating medium. The size of the crystals depends upon the nature of freezing in slow or quick freezing. Large crystals formed in slow freezing, ruptures the tissues more since it penetrates the cell wall easily and forms the drip. Drip is the flow of tissue fluids from the frozen fish or muscle during freezing of the fish or muscle. This drip is due to the cell damage caused in freezing. This drip leaches along with soluble protein, vitamins and minerals and gives an undesirable appearance. The formation of drip affects the appearance of the product and results in the loss of weight. Hence drip is considered as one of the criteria for judging the quality of the frozen products.

When fish is intended to be stored for a long period, quick freezing is preferred which inhibits bacterial action. During quick freezing every part of the product comes within the range of  $0^{\circ}$  to  $-5^{\circ}\text{C}$ . Properly frozen fish at  $-20^{\circ}\text{C}$  retains its physical properties and nutritive value for a year or more and is almost as good as fresh fish. Smaller sized crystals, shorter time taken for freezing less time allowed for diffusion of salts and evaporation of water and prevention of decomposition are some of the advantages in quick freezing. There are three ways effecting the quick freezing: a) Direct immersion of fish in the refrigerating medium b) Indirect contact with the refrigerant through plates and c) Forced convection of refrigerated air directed at heat transfer surfaces. There are several methods of quick freezing. Among the various types of quick freezing plants installed in India the carrier air blast type is widely used.

Preserving of fish in cold storage is practiced on a small scale in India. Cold storage preservation of fish is practiced at the places where storage facilities are available. The fishes are preserved overnight in cold storage and marketed the next day. With the increase in availability of ice, fish is transported in ice by different modes of transport like rail, trucks, motor launches etc. The west coast has a large number of freezing plants at places like Bombay, Mangalore, Cochin, Trivandrum where freezing of prawns, lobsters and frog legs are undertaken. At Bombay fishes like pomfrets, jew fishes etc., are frozen and stored for several months.

Oil Sardines (*Sardinella longiceps*), mackerel (*Rastrelliger kanagurta*) and Seer (*Scomberomorus guttatus*) are the three commercially important food fishes used in the application of refrigerated sea water for preservation. These fishes were stored in artificial sea waters prepared by dissolving common salt to give a sodium chloride content 3.5% at a temperature of  $-1.1$  to  $0^{\circ}\text{C}$ .

In general the fishes stored in refrigerated sea water had firmer texture and better appearance than ice-stored ones. The oil sardines stored upto 2 days did not show any difference compared to ice samples. Further storing resulted inferior quality of the fish. Similarly mackerel and seer could be stored for 4 to 6 days and 12 to 14 days respectively.

In general different methods of freezing are adapted through sharp freezer, Air blast freezer, Contact plate freezer, Vertical plate freezer, Immersion freezing, Liquid freon freezing, Liquid nitrogen freezing, Fluidized bed freezer, Cryogenic freezing, sub freezing etc. All the methods of freezing shall help in absorption of heat and in preserving the initial qualities of fish.

Among the various methods of freezing the blast freezer is mostly in use in India. The air blast freezer is in the form of a tunnel and heat transfer is effected rapidly by the circulation of air. The temperature used ranges from  $0$  to  $30^{\circ}\text{C}$  and air velocity varies from 30 to 1050 meters/mt.

#### Filleting and freezing of fish

The processing industry also adopted the freezing of fish in the form of fillets at times when the prawns are not available. Fillets are nothing but the strips of flesh cut parallel to the backbone of the fish. Fishes like *chanos chanos*, cat fish, perches, mullets, carps, eel etc., are suitable for filleting and freezing. Filleting can be done by hand which is economical or by using a filleting machine. Fillets may be with or without skin and it fetches a much higher price in the luxury

market. The fillets are dipped in brine to enhance their appearance and to reduce the amount of drip and it also gives a salty flavour. The freezing of fillets can be an individual quick freezing or block freezing. After dropping in brine, the fillets were wrapped in polythene sheet and frozen in contact plate freezer at  $-35$  to  $40^{\circ}\text{C}$  and stored at  $23^{\circ}\text{C}$ . In block freezing the fillets in known weight 500 gr, 1 Kg, or 2 Kg are packed in polythene bags lined with wax and sufficient quantity of glazed water is poured to cover the fillets. The fillets are put in a freezer at  $-35$  to  $40^{\circ}\text{C}$  and stored at  $-23^{\circ}\text{C}$ .

**Drying** is a process where moisture is removed from the tissues of the body of fish. The drying process can be through blowing air which removes water vapour, by natural drying (By sun drying, outdoor drying) or artificial drying (Using dryers). After the removal of moisture the bacterial and enzymatic putrefaction is stopped. Sun drying is the simplest method followed for preserving the fish. One third of the marine catch in our country is exposed to sun drying. Freshwater fishes are dried in small quantities. Outdoor drying required dry atmosphere, sunlight and a slight breeze.

The sun drying process can be observed all along the coast in the open sandy beach. The fish after its landing is cleaned with sea water and spread in a thin layer on coir mat and exposed to sun for a day or two care is taken to turn the fish for uniform drying and to avoid contamination with sand from the ground. In another method of drying, fish is dried by hanging on bamboo or wooden rods or on ropes stretched horizontally between vertical poles. Bombay duck is an example. This method helps in uniform drying and avoid bug contamination with sand. Large and medium sized fish are generally split and salted before drying. Sun drying is a slow process and results in much loss through spoilage. The odour developed in the fish during the sun drying may not be acceptable to some people due to variations in the moisture content and chemical qualities. The fishes which are not dried on account of improper sunlight are used as manure. Moisture content can also be eliminated by using artificial dryers or mechanical dryers. The fish with the nutritive value can be kept for a longer period than the sundried fish. The fish can regain fresh state if soaked in water while the sundried fish cannot attain the gelatinous character of the fresh fish.

Thus the air temperature plays an important role in drying. Increase in temperature raises the efficiency of operation. The drier the air the higher the drying rate.

### Salting

Salting is a process where the common salt, sodium chloride, is used as a preservative which penetrates the tissues, thus checks the bacterial growth and inactivates the enzymes. Salting commences as soon as the fish surface of the fish comes in contact with common salt and the end product shall have the required salinity with taste and odour.

Some of the factors involved in salting of fish which play an important role are purity of salt, quantity of salt used, method of salting and weather conditions like temperature etc.

During the process the small fishes are directly salted without being cleaned. In the medium and large sized fish the head and viscera are removed and longitudinal cuts are made with the help of knives in the fleshy area of the body. Then the fish is washed and filled with salt for uniform penetration through flesh. Large fishes like sharks are cut into convenient sized pieces. Generally, sardines, mackerels, seer fishes, cat fishes, sharks and prawns are used for salting.

The salt used should be pure common salt so as to keep the quality of the fresh fish. Traces of calcium and magnesium caused whitening and stiffening of the flesh and gives bitter or arid flavour to the product. In addition it does not allow the easy penetration of common salt.

Dry salting, wet salting and mixed salting are the three methods employed in salting of fish. In dry salting process the fish is first rubbed in salt and packed in layers in the tubs and cemented

tanks. The salt is applied in between the layers of fishes in the proportion of 1 : 3 to 1 : 8 salt to fish. The proportion of salt to fish varies with the fish since the oily fish require more salt. At the end of 10-24 hours the fishes are removed from the tubs and washed in salt brine (Salting vessel) and dried in the sun for 2 or 3 days. Large fish lose about one third and small fish about one half of their dressed weights.

In another method known as *wet salting* the cleaned fish are put in the previously prepared salt solution. It is stirred daily till it is properly pickled. In some fishes like seer, black pomfret and Indian salmon etc., the gut is removed and filled with salt in 1 : 3 proportion. First the salt is filled in the gut region of the fish and stacked, on the following day further addition of salt is done since the salt settles down at the bottom. Finally the process is repeated to ensure the proper filling up of salt and left undisturbed for 7-10 days allowing the liquor to flow off. This method is mostly followed in Eastern parts of our country. In Western parts the gut is removed and the salt is applied in one lot and they are arranged in bamboo baskets. The fishes preserved in wet salting process are to be consumed before the rain sets in and the fishes are marketed without drying.

**Pit curing** is another process employed in south and south east of our country. In this process the fish treated with salt are buried in pits lined with leaves. After 2-3 days they are removed and marketed directly.

In *mixed salting* process, simultaneous use of salt and brine (Salt water) is followed. The salting process is continued till the concentration of salt in the surrounding medium equalises with the concentration of salt in the fish tissue. The salting process may affect the shape, structure and the mechanical features of muscle tissue.

### **Smoking**

Smoking or smoke curing of fish is one of the methods of preservation combined with drying and deposition of smoke constituents. There are four basic treatments followed in this process. They are brining, drying, smoking and heat treatment. The smoking process provides desirable smoky flavour and attractive appearance.

First the fish after dipping in salt water is suspended on rods and placed above the barrel known as 'Kiln' through which smoke is allowed to pass through from the smoking pits at a temperature above 60 °C. The smoke allowed may be hot or cold, heavy or light depending on the required product. In cold smoking the smoke is allowed through a pipe at a temperature of above 30 °C from a distantly located pit. Fish in large quantities may be smoked by placing them in a small shed.

Formaldehyde, acids, and phenols, phenolic constituents used in smoking are found to be effective in preserving fish. Sardines, mackerel, pomfrets, jew fishes, ribbon fishes and hilsa give smoked fish of excellent quality.

### **Canning**

Canning is a method of preservation in which spoilage can be averted by killing micro-organisms through heat. It is generally well known that food carries micro-organisms which cause spoilage if left unchecked. These micro-organisms are to be eliminated and the entry of others are restricted. The canning process involves the pretreatment of fish, preparation of can, filling and closure of the can, technique of heating the filled cans to kill micro-organisms without damage to fish, finally cooling, cleaning and storage of the product.

The raw material should be processed properly since it contains most dangerous spore formers *Clostridium botulinum* which should be destroyed. This is found in protein rich food such as fish which has a pH 6-7 and is nonacidic. There are some other heat resistant bacteria

like *Clostridium sporogenes* which can be eliminated at a temperature of 5-6 times more than *Clostridium botulinum*. It needs a temperature of 120 °C for 4 minutes or at 115°C for 10 minutes to kill them in large numbers.

### 17.3.2 Pretreatment of raw material before canning

#### a) Dressing

In the beginning the fish should be dressed properly. Dressing includes sealing, removal of head and intestine and sometimes removal of backbone in large fishes. Beheaded fish is placed on rods for smoking prior to canning. Smaller fishes are cut mechanically and packed lengthwise in the can. After the removal of head and gut the blood should be allowed to drain off. These dressed pieces should be given a final washing with chlorinated water which removed bacteria which forms the source of contamination.

#### b) Salting

The next step should be to stabilize the flavour and to retain its characteristic taste through salting and brining procedure.

The fishes should be salted i.e. by mixing the fish with dry salt or by immersion in brine. After passing through the different steps the fish retains the desirable concentration of 1.1 to 1.6% salt. Salting should be done to obtain uniform salting in fish. The purity of salt used is also an important factor. Salt pellets may be added to the fish in the cans before processing.

#### c) Pre-cooking

Pre-cooking is a process where the fish is heated enough to remove the excess of water from proteins. If water is not removed it leads to various disadvantages. Water content of fish should be reduced to atleast 60%. In the process the fishes tend to lose their weight. Pre-cooking in brine is more satisfactory than in steam or hot air.

#### d) Drying

Hot air currents are used to remove moisture in cooking process. This increases the quantity of oil. Excess drying results in a tough texture. This drying process can be undertaken in well covered ventilated places.

#### e) Smoking

The smoking method is employed to provide flavour to canned fish in addition to removing moisture. In this process the fishes are hung on rods and passed through a smoking tunnel for the purpose of smoking. The recent method of electrostatic smoking has resulted in a satisfactory flavour with less satisfactory colour of the fish. Only difficulty encountered is electrostatic smoking takes 10-30 minutes with similar taste result.

#### Cans

Cans are made up of tin plates in canning industry. The tin plate is a thin steel sheet coated with tin on both sides. Which has a combination of strength of steel and protective properties. The tin plate has corrosion resistance, since it is covered with 4 layers namely alloy, tin, protective oxide and oil in addition with special enamels or lacquers which have been developed. Various types of inorganic lacquers are used to absorb the sulphur. Seafoods when canned produce sulphur ions which may react with the coating of tin. These sulphur ions are not detrimental to health but affect the appearance of the product.

Other materials like sulphur resistant black plate, steel coated with aluminium, zinc, nickel or titanium have been tried but its application is found to be very little. Glass jars are also tried which requires longer processing time than tin plates.

The prepared cans should be protected against damage and corrosion and should be stored in dry closed room. The cans should be thoroughly washed with boiling water before filling to avoid dust and micro-organisms if any present in the tin.

#### 17.3.4 Methods of canning

##### a) Filling

Empty cans should be packed carefully by employing the manual labour or through mechanical device. While packing, care should be taken to see that no air pockets are left which cannot be removed by exhausting. At the same time too tight packing should be avoided. It is always better to leave some space at the top for accommodating gas released while processing.

Fatty fishes (Salmon, herring, mackerel etc.) results in acceptable products when salt is added. Non-fatty fishes call for special additives to improve flavour and texture. Brine is used when fish is not salted properly as an additive for enhancing flavour. Glutamate (Monosodium glutamate) is used as additive for canned fish at a concentration of 1.6 gr., per Kg fish. Vegetable oil and olive oils are also used for filling the cans.

##### b) Exhausting

The air and gas from the can should be removed before its sealing process. This can be done by using exhausting which minimises the strain on the can through expansion of air during heat processing. Removal of oxygen to avoid internal corrosion and creation of vacuum when the can is cooled are indication of sound packing since it protects colour and flavour of products and retains vitamins etc. Further it checks the growth of organisms which requires air for growth.

Later sealing is done to obtain air tight seal between the cover and the body of container so that the spoilage agents cannot enter the sealed container after the canned fish has been sterilized.

##### c) Processing

Removal of air as completely as possible is an important factor in steam processing. The container along with the contents in fish is heated in a retort at a temperature which is sufficient to kill the potential inactive spoilage agents without any damage to fish. The retort systems can be operated continuously or in batches. In the recent times open boilers are being tried. Thus pressure processing either by steam or by water is deployed in this processing.

The majority of retorts, may be horizontal or vertical still, or rotating, are fed by steam. The report shall have an inlet at the top through which steam enters. The weight of the steam that entered the report and the incoming steam both put together drives the air out from the bottom without mixing. Air pockets if present in a report may give rise to uneven processing and lead to under processing while interfering between pressure and temperature. The processing time and temperature required for each food depends on various factors like types of pack, size of cans report system etc.

By adopting the above heating process the majority of the spoilage agents or bacteria are killed. If any bacteria remains unkilld they can be eliminated by subjecting it to rapid cooling immediately after processing. The can should be cooled to a temperature of 35 °C which is sufficient for rapid drying of the can surface. It protects against rusting. Chlorinated water of 5 ppm strength can be used for cooling purpose. Even with careful regulation of pressure during and after processing, sometimes the cans are exposed to temporary leaks. Through these leakages the bacteria may enter after processing. Hence to minimise this, chlorinated water is used for cooling.

The canned product should not be transported immediately since the salt pellets and other additives used may take some days for equal distribution throughout the can contents. It is advised to store for 3 months before final quality control and shipment. During this period all cases of leak contamination would show up.

#### d) Microbial spoilage

Sometimes the canned fish show signs of microbial spoilage which may be due to insufficient pretreatment especially inadequate cooling or improper preservation of raw material. It exhibits signs of spoilage accompanied by the presence of dead bacteria. These bacteria may at times withstand the processing but shall die during cooling and storage. Insufficient processing leaves back a number of heat resistant spore forming bacteria in the canned product. The commonly observed sporeformers are mesophilic anaerobes (*Clostridium sporogenes*, *C. putrificum*). They produce putrid swells, mesophilic arobres (*Bacillus sp*) produces flavour and colour changes and softens the contents. Thermophilic bacilli produce 'flat sours' which are rare. The bacteria has got ability to produce gas and to interact with the material inside the can. The gas accumulated at the head region in the can helps in determining the kind and cause of spoilage. The swelling of cans may also be due to CO<sub>2</sub> and hydrogen formed due to microbial spoilage.

Finally the canned product is thoroughly examined by various methods like examining the product organoleptically, chemically and micro biologically for the quality of final product. Then it is properly labelled which should exhibit the name of the product, net contents and any specific information if required. The processed cans can be stored at a room temperature which should be just above the freezing point of canned products.

---

### 17.4 TRANSPORTATION OF FISH

---

In modern times, fishing and fish processing industries have made rapid progress. The most important method of economic utilisation of fresh fish involves the transportation. The fish catch which is on the increased trend will have to be lifted from the landing area to the place where it is easily marketed. But our country has a varied landing centres widely scattered on the long coast line of about 4,800 Kms.

In the earlier times the heavy catch and very heavy landings of fish were buried in coconut gardens and later used as manure. In addition the surplus fish catch was salt cured and such products used to attract low prices. All these methods were adopted for want of proper transport facilities and scientific methods of handling and preservation. Hence rapid mechanisation of fishing crafts is gaining lot of importance since the fish is to be transported from the place of landing to the internal markets, which are situated some thousands of kilometers away. The fish catch is not reaching the common consumer because of the problem faced in selection of container-method of icing and transportation.

The fish processing industries aimed at fish product export and earning foreign exchange thus neglecting the fish consumers in India. Even till today the consumer is not getting average fish requirement. Various countries have made tremendous progress with the mechanised transportation while our country is yet to standardise the method.

Modern method of preservation like freezing and canning alone are used for preserving prawns which constitutes 10-12% of Indian marine fish landings. Since the other 90% of marine fish landings forms the fishes which finds no export market, not much of attention is diverted towards, handling and transportation. Use of trucks and vans to some extent eased the situation in transporting the fresh fish in coastal area. Recent introduction of refrigerated rail wagons in certain routes connecting the cities also helped in distribution of fresh fish.

The fish which is a perishable commodity is exposed to spoilage due to death after its landing through micro-organism which cause deterioration. Hence to avoid the spoilage the crushed ice

is used to keep the fish fresh for limited time of preservation. Re-icing should be done where ice melts away at an interval of 24 hours. Non-availability of ice or economy in the use of ice etc., have lead to the recent finding of a container which checks the melting of ice. Traditionally bamboo baskets lined inside with bitumen coated craft paper, gunny and polythene, palmirah leaf mat and banana leaves were used for transportation of fish. Storage of fish packed with ice in the proportion of 1:1 was followed.

The bamboo baskets were of shallow type made from split bamboo. The gunny was stitched to the inner surface of the basket and 300 gauge polythene was spread over it to protect the gunny from becoming wet when iced fish was kept. The union kraft paper lining was also used for the inner surface of the basket. Holes were made to the liners at the bottom to drip away water from melting ice. Fresh jew fish and sardines were transported by this process.

Many fishing nations of the world have advanced in transportation and in distribution of fresh fish, established the cold storages, ice plants, use of modern containers, refrigerated vehicle for fast movement of fish etc., involving huge investment. Since it involves huge investment our country has developed a cheap but efficient container for transportation of fish. The container which is a second hand teachest the melting of ice while maintaining the temperature upto 60 hours. The container may be of two sizes with its carrying capacities are 48.2 x 48.2 x 58.5 cms - 110 Kgs, and 45.5 x 45.5 x 51.0 cms - 80 Kgs. A 25 mm thick thermocole is cut to required sizes to fit into the inside of the container with polythene bags to protect it from ice melted water on all 6 sides. The thermocole does not allow the entry of heat from outside and the cold from inside to escape.

The fish is washed repeatedly with 5 ppm chlorinated water till the fish is free from slime, sand, dirt, blood or any other foreign matter. The ice blocks are crushed to make the ice free from any contamination with bacteria. A 1:1 proportion of ice by weight 1 Kg of ice to 1 Kg of fish is put into the container. First the ice is spread on the bottom of container and over it the washed fish is laid. Again above the fish layer the ice is spread the fish is laid. Thus ice and fish should be arranged on alternate layers till the required weight of the fish and the ice fills the container. The top layer should be of ice. Care should be taken to see that there exists a close contact of ice with fish. Finally the last sixth piece of themocole is placed above the box and the lid is placed. This lid should be nailed to the box. The container finally wrapped in gunny bag should be stitched properly before final transportation.

Depending on the duration of transport the ice can be packed with more provision for fish. If transport duration is less than 24 hours only 3/4 or 1/2 of the quantity of ice may be used. If it is for longer period before marketing and distribution, use of more ice is advised to the container.

The container which is ready for transport is loaded into the rail wagons or trucks without leaving any space in between the boxes, thus avoiding the rate of melting of ice. Containers should not be exposed to direct sunlight. The containers can be properly cleaned and dried for re-use. They can be used on an average of 3 trips involving journey of 40 hours. The cost of container, thermocole, polytherne, gunny bag, nail etc., varies from time to time. The exact cost cannot be specified at a particular level.

The fishes landed in huge quantities at the centre can be deep frozen and stored if the facilities for immediate transport are not available from the landing area. The freezing can be done in metallic trays partitioned to hold the fish of 1 Kg or 2 Kgs. The interspace is filled with good quality water. Freezing continued for 2 1/2 to 3 hours at - 40°C. The frozen blocks were removed from the trays and packed immediately in the container. This type of freezing facilitates small size fish like sardine mackerel etc., While air blast freezer or tunnel freezer is used for large size fish individually. This method is better for transportation involving journey of 2 to 3 days.

The only difficulty encountered in this type of freezing is that belly bursting occurs during freezing and transportation and the entire visceral portion comes out reducing the acceptability by the consumer. Hence to overcome such hardships it is advised to give a dip treatment of fish in

15% brine for 30 minutes prior to freezing and the fish gives slightly saltish taste on cooking in water, with better appearance and firmer texture to the sardines.

The dry ice (Solid carbon dioxide) can also be used for supplementary cooling of already chilled or frozen fish during transportation in insulated cans. Initial cooling with dry ice should be avoided as it does not provide uniform cooling and causes freezer burn in fishes.

Thus the development in scientific field of preservation, processing and transportation shall enable the private entrepreneurs in the various places to accept the challenge and derive the full advantage. The method of packaging and transportation in the improved condition will not only improve the socio-economic status of fishermen but also solve the problem of the protein malnutrition of our country.

#### Check your Progress

- 1 \_\_\_\_\_ is another good method of preserving fish.
- 2 \_\_\_\_\_ canning is more suitable method of preservation, because it prevents fish from attack of even \_\_\_\_\_.

---

### 17.5 SUMMARY

---

Here the preservation of fish by various methods is described in detail. Preservation methods such as freezing, filleting Drying, Salting, Smoking and canning are explained here. Even the transportation of fish to preserved fish are described here.

---

### 17.6 CHECK YOUR PROGRESS - MODEL ANSWERS

---

1. Salting
2. Micro Organisms

---

### 17.7 MODEL EXAMINATION QUESTIONS

---

#### I. Answer the following in about 30 lines :

1. Describe the various methods of fish preservation and processing technologies developed in our country.
2. What is canning ? Explain the methods followed in canning process technology.
3. Explain the pretreatment given to the raw material before canning.
4. Give an account of the recent advancement involved in the transportation of fish.
5. Briefly write about the refrigeration and freezing process adopted in fish preservation.

#### II. Answer the following in about 10 lines:

1. Explain how the freshness of fish can be tested.
2. Write briefly how the spoilage of fish is determined.
3. Drying process of preservation.
4. Salting process of preservation.
5. Smoking process of preservation.

---

# UNIT - 18 BY PRODUCTS

---

## Contents

- 18.1 Objectives
- 18.2 Introduction
- 18.3 Composition
  - 18.3.1 Enzymes
  - 18.3.2 Vitamins
  - 18.3.3 Phospholipids
- 18.4 Fish By Products
  - 18.4.1 Fish Oils
    - 18.4.1A Composition of Fish Oil
  - 18.4.2 Fish Meal
  - 18.4.3 Fish Flour
  - 18.4.4 Fish Silage
  - 18.4.5 Fish Solubles
  - 18.4.6 Fish Proteins
  - 18.4.7 Shark Fins
  - 18.4.8 Fish Eggs, Fish Roes
  - 18.4.9 Fish Glue
  - 18.4.10 Isinglass
  - 18.4.11 Fish Skins
  - 18.4.12 Sterols
- 18.5 Summary
- 18.6 Check Your Progress : Model Answers
- 18.7 Model Examination Questions

---

## 18.1 OBJECTIVES

---

This unit deals with the importance of fish which is consumed as food either in fresh condition or in the form of preserved products. The flesh of fish contains various important chemical composition which differs in marine and fresh water fishes. Various by products are obtained from the entire fish body or from important organs of fish which has a great value in human nutrition. The products of inferior quality is used as manure.

---

## 18.2 INTRODUCTION

---

The good quality fish meal is used as supplement in animal feeding, while others are used as manure. The chemical composition of marine and fresh water fishes includes minerals,

enzymes, vitamins, proteins, phospholipids etc. The fish protein plays an important role in human nutrition in view of its high digestibility and biological and growth promoting value. Fish oils, fish meal, fish flour, fish silage, fish roes, fish glue, isinglass etc. are some of the by products obtained from fish. The fish oil, liver oil, cod liver oil, shark liver oil, sardine oil etc., are rich in vitamins and have specialized methods of extraction. The fish oil is useful in manufacturing of candles, lubricants, cosmetics and pharmaceuticals also. Shark carcass and Salmon cannery waste is used in cosmetics soaps, chemical industries, chocolates, pharmaceuticals etc. The by products have varied composition and important used in various industries. Fish meal is used for animal feeding and as manure. Fish flour is used for human consumption. Leather gelatin and glue are produced from fish skins, imitation pearls and carbon from fish scales, foam producing compound for fire extinguishers, isinglass and adhesives from fish sounds (air bladder), insulin from pancreas, sex hormones from gonads, protein from milt, histamine from flesh, guanine and cystine from scales and some of the products obtained from the wastes of fish.

---

## 18.3 COMPOSITION

---

The flesh of fish contains 80% moisture and oil, 15-25% of protein, 1-2% mineral matter, and 1% other constituents. The chemical composition of the Indian marine fishes differs from that of the freshwater fishes. The percentage of protein ranges from 9.05 (Bombay duck *Horopodon nehereus*) to 26.10 in grey shark *Carcharhinus limbatus* while in freshwater fishes it ranges from 13.7 (Bhekti, *Lates calcarifer*) to 25.2 (Mahseer, *Tor tor*).

The other mineral constituents present in fish muscles are copper, manganese, strontium, zinc, aluminium, barium, lead, molybdenum, vanadium, bismuth, cobalt, nickel, titanium, chromium, silver, mercury, niobium, boron, lithium, antimony, silicon, radium, bromine, fluorine and iodine. Cadmium and gold are present in few species. The availability of these minerals vary from fish to fish.

Calcium and phosphorus can be obtained from the bones of fish like silver belly which is eaten as whole along with the flesh. Calcium alone can be obtained from bones as well as scales from few teleost fishes. Variation in phosphorus is related to the availability of protein. Potassium is available slightly more than sodium from the tissues of marine and freshwater fishes. 0.2% and 0.02 to 0.3% of chlorine is available in the fresh muscle of marine and freshwater fishes respectively.

Carbohydrates are available in very small quantities while glycogen present in living fish is rapidly converted to lactic acid after death.

The nitrogenous constituents present in fish muscle are volatile bases (Ammonia, mono, di and trimethylamines), trimethylammonium bases (trimethylamine oxide and betaine), guanidine derivatives (Creatine, methylguanidine etc.), glyoxaline derivatives (Carnosine, anserine and histidine), urea, amino acids and purine derivatives. Non protein nitrogen forms 7.5 to 17.1% of the total nitrogen and amino acids in this non-protein nitrogen varies differently in different fish species. Urea forms 50 of non-protein nitrogen in elasmobranchs. The freshness of fish can be estimated by the presence of trimethylamine formed as a result of spoilage. Histidine which emits characteristic meaty flavor undergoes decarboxylation to histamine during spoilage which is responsible for food poisoning. Sardines, herring, mackerel, tunny etc., possess basic amino acids like histidine. Creatine, phosphoric acid and Amino-octanoic acid and also identifies in some of the fishes like *Horopodon nehereus* etc.

### 18.3.1 Enzymes

The fish muscle is greatly enriched by the presence of various important enzymes in its composition. Reports of occurrence of proteolytic enzymes like amylases, thiaminase, adenosene triphosphatase, choline esterase and other esterases, nuclease, butyrylase, glycogenase have been made both in

freshwater and marine water fishes. The enzyme namely thiaminase does not occur in sea water fishes.

### 18.3.2 Vitamins

Vitamins A, D and B. Complex, B12 C are present in the quality fish. The main components of B. Complex are thiamine, riboflavin and nicotinic acid. The vitamin B 12 in high concentrations is present in the liver and in fair amounts in flesh along with vitamin C.

The marine fishes obtained from the sea shore of Bombay have revealed the presence of B. Complex components namely thiamine 0.1 - 1.1, riboflavin 0.5 to 12.9. and nicotinic acid. 2.7 -48.2 mg. The fishes obtained from the freshwater bodies in West Bengal are found to contain, 2.03-37.74 mg/g as chloride. The B12 Vitamin of Indian fishes varies from 50 to 210 mg/g.

### 18.3.3 Phospholipids

Phospholipids constitute 0.17 to 0.7% of the muscle among the several kinds of fish. The flesh of cod has a complex mixture of phospholipids, lecithin predominating the other lipids and constituting 50 to 60% of the total phospholipids present. A study of Phospholipids content of Indian (Bombay) fish revealed that total phospholipids on a dry weight basis varied within a range of 4.3 - 5.7% with lecithins predominating (2.3 - 3.6%) followed by spingomyelin (0.2 - 0.6%) and cephalin 0.9 to 2.2%. Total cholesterol in fish muscle varied from 0.3 to 0.8% and free cholesterol 0.15 to 0.5% on a dry weight basis.

A group of uncharacterised phospholipids designated as and phospholipids A, B and C have also been separated but their content is much lower than the other known phospholipids like lecithins and cephalins.

---

## 18.4 FISH BY PRODUCTS

---

The various by products derived from the fish are the Fish oils, Liver oils, Fish meat, Fish flour, Fish silage, Fish solubles, Fish proteins. Shark fins, Fish roes, Fish glue, singlass, Fish skins, Sterols etc.

### 18.4.1 Fish Oils

The oils from the fish are obtained by extracting from the entire body of the fish or only from the liver. The oil obtained from the entire body are known as body oils and are grouped into drying and semi drying oils. The drying oil comprises oils of sardine, salmon, herring, mackerel, anchovy and white fish, while the oils of sprat and carp constitute semidrying oil due to the low iodine content. The body oil is edible and used for industrial purposes. Liver oil extracted from the liver, is of medicinal importance and contains vitamin A. The flesh with rich oil content possesses liver with low oils content and the liver with rich oil content is associated with flesh with low oil content.

Freshly extracted oils are differently colored from colourless to golden yellow, greenish yellow or even red. The oil extracted from the stale fish is darker in color characteristic and concentration of the oil also varies from fresh to stale along with iodine content.

### Composition of Fish Oil

The fish oil differ very much in their composition and against the comparable oils of other terrestrial animals and vegetable fats. The fish oils are much more complex and the fatty acids are composed of chain lengths varying from C-14 to C-22 and in some instances even C-24. Higher chain lengths are not uncommon. These fish oils have also varying degrees of

unsaturation ranging from mono upto penta (5) and have (6) ethylenic acids. Oils of marine fish varieties have a higher concentration of C-20 and C-22 (i.e., longer chain lengths) and lower concentration of C-16 and C-18 acids. The saturated acids mainly palmitic, form only 15-20% of the total acids. The fatty acid composition of flesh and liver oils of fish are similar with body oils containing higher proportion of unsaturated C-20 and especially C-22 acids.

The fish oils are comprised of a mixture of triglycerides which are comparatively more complex. Simple triglycerides are either absent or of very rare occurrence. The most common triglyceride is a compound containing three different fatty acids although occasionally two radicals of the same fatty acids are found over a single glyceride molecule.

The amount of unsaponifiable matter in fish oil shows great variability. Shark liver oils being rich in is constituent. The unsaponifiable matter is comprised of a variety of alcohols and other hydrocarbons. All fish oils contain cholesterol.

### Liver Oil

Fish liver oil consists of vitamin A mainly and D in some species. These vitamins may be formed due to metabolic activities which might have been made their way into the liver and to be stored. Unsaponifiable matter in the liver oils of food fishes is lower in 0.1 to 2.4% in cod than in other liver oils i.e., 80% in a few sharks.

The livers of fishes are grouped into three classes depending upon the commercial utility viz.

Class	Example	% Oil	Vit. A potency
High oil content with low vitamin A potency	Cods	60 - 75	500 to 20,000 i.u./g.
Low oil content with high vitamin A potency	Tuna halibut	4 - 28	25,000 to 6,00,000 i.u./g.
High oil content with high vitamin A potency	Hamer headed shark	25 - 75	3,00,000 i.u./g.

Vitamin A mainly gets stored in the liver. But in halibuts the Vitamin gets accumulated in viscera also in addition to liver. The age, sex, availability of food, season etc., play an important role in the activity of vitamin A can be obtained from the large sized fish within a given species. No such correlation of size and concentration of Vitamin A can be made among the fish of different species. The dark coloured liver in sharks yields higher concentration of vitamin A than the light coloured ones. Vitamin A content of liver lobes are varies markedly in different lobes.

Vitamin A which is associated with the protein of the liver and partly with the oil exists as fatty acid esters (96 - 100%). Vitamin A comprises Vitamin A2 (from the liver oils of marine (from the liver oils of freshwater fishes) which is 40% active as A 1. Vitamin A 1 is of greater importance in view of its availability in commercial scale.

Three cis-isomers viz. neovitamin A, 'iso-a' and 'iso-b' have been isolated from the liver oils but are less potent than Vitamin A1. Some fish liver oils are rich in Vitamin D. Tuna liver oil, halibut liver oil and cod liver oil contain 2,50,000; 5,000; 500 units per gram of oil. Vitamin D content is available in greater quantity where the oil is less in the liver. The Vitamin D is present in the form of D3, available partly in free state and partly as esters.

Vitamin E in liver oils protects any oxidation of Vitamin A. Hydrocarbons cholesterol pigments fatty alcohol and glycerol others form the various constituents of the oil besides glycerides.

## Extraction

For extraction of the oil from the liver it is advisable to collect the livers from the fish and stored till the process of extraction. Viscera also are collected from some fishes like halibut and are stored separately. The material thus collected must be given preservative treatment to prevent microbial decomposition of the oil and formation of free fatty acids. Vitamin A is quite stable within the liver. The material may be preserved in common salt or frozen or treated with formaline.

Sound livers, fresh or suitably preserved, are used for the production of medicinal grade oil while diseased or discoloured livers are used for the production of technical grade oil. Hence the process of extraction depends mostly on the presence of oil content in the liver and the Vitamin A potency. A simple method of steaming is followed for obtaining the oil from the livers of fish such as cod which has high oil content. The liver is minced and cooked in tanks at a temperature of 85 - 90°. The liver cells disintegrate and the oil floats to the surface of the steam condensate. The oil is skimmed and collected.

In another method known as flotation process the procedure is somewhat elaborate. First the liver is collected and preserved with aquacide (a mixture of paraaldehyde and sodium carbonate). This denatures the protein and yields a pulp when the separated aqueous liquid is drained off. The pulp is then allowed to pass through a series of tanks or cylinders with a stirrer, which are connected to worm water pipes. The emulsion of oil and water formed during the treatment breaks suddenly and oil floats to the top.

In the steaming process the oil is not fully extracted from fishes which is poor in oil content but with high Vitamin A potency. The proteins present in the liver hold up the release of liver oil. In such cases other techniques like digestion of liver protein with alkali is adopted as in the livers of halibut, tuna and sharks. The material is ground mixed with diluted caustic soda 1-2% by weight or sodium carbonate 2-5% and digested with live steam at a temperature of 82-88°. With constant stirring for about an hour, the material is passed through centrifugal machine. The liver may be treated with sardine oil for separating the vitamins.

The enzyme alkali digestion process can also be undertaken for the extraction of oil. In this process minced liver is mixed with an equal volume of water, pH adjusted to 1.2 to 1.5 by addition of hydrochloric acid, pepsin (0.5% by wt of liver) added and the material digested at 43-49°. At the end of the process sodium carbonate is added to raise the pH to 9.0 along with the raise of temperature to 80° to cook the material for about 1 hour. Later the oil is drawn off and filtered.

The yield obtained in the digestion process is comparatively low than the yield obtained by employing solvent extraction used for separating the oil from livers. The oil obtained through this process is darker in colour and with high viscosity and is to be refined after extracting free fatty acids from the liver.

The oil thus collected from any one of the methods should be allowed to stay undisturbed for sometime till water and soil particles settle to the bottom. The oil containing the stearin in the form of sediment is passed through filtration, centrifuging and treatment with fuller's earth. The oil is extracted and stored at low temperature. The stearin can be separated by cooling the oil at 0 - 10°, the oil is filtered at low temperature.

Liver oils with low potency are used as vitamin supplements to animals and those with high potency the oil is used for medicinal purpose. Liver oils are found to be very active sometimes reducing the blood pressure of animals.

### Cod Liver Oil.

Cod liver oil is obtained from different types of cod fishes like *Gadus callarius* (Linn) and *Gadus morrhua* (Linn) and other cods. The fresh liver of these cods are passed through steam cooking

process and later cooled at 0° to eliminate the stearin. A good quality cod liver oil is pale yellow and slightly soluble in alcohol and mixes with solvent ether, chloroform and light petroleum and remains bright at 0°

The liver oil consists of fatty acids which vary differently in different fishes. Sometimes the unrefined oil contains iodine (3-15 ppm) and traces of arsenic (1.4 to 5.1 ppm).

The inferior quality oil is of dark colour, acrid or bitter and acidic. Vitamin A in the oil gets destroyed when exposed to sunlight and the oil becomes thicker when exposed to air. Hence the oil should be properly stored to avoid the destruction of vitamin A by addition of certain preservatives like nordihydroguaiaretic acid (0.05%) and ascorbyl palmitate (0.01%).

In view of rich concentration of vitamin A and D, with digestible fat it is found to improve nutrition and calcification in patients with rickets and tuberculosis when used. It can also be used as a supplement for children and can be applied to wounds and burns. Iodinated oil is used for several skin infections like eczema and mycoses.

The cod liver oil can be extracted from partially or completely decomposed livers. The oil is considered as low technical grade oil and is used in the manufacture of leather, lubricating greases and soaps of inferior grades. The stearin separated at low temperature is used in soap making or as fish tallow in leather curing.

Halibut liver oil is obtained from fresh or preserved livers of *psettodes* sp. by solvent extraction or alkali digestion. It is pale to golden yellow in colour with a fishy but not rancid odor and taste. It is similar to cod liver oil composition. Cod and halibut liver oils have not much of medicinal importance nor are they used in the preparation of vitamin concentrates. Tuna and shark liver oils are rich in vitamin A and D. In India cod liver oil is not produced but the liver oils for commercial production are extracted from sharks which are supposed to be rich in vitamin A and D at different places like Bombay, Baroda.

#### Shark Liver Oils

Sharks of Indian waters except few are considered highly important from the yield point of oil from liver which consist of high vitamin A potency. (av. 12,000 i.u.g of oil). Oils as rich as 3,00,000 i.u./g have been obtained.

The shark liver oil is obtained from species of sharks like *Galeocerdo tigrinus*, *Carcharhinus melonopterus*, *C. menisorrhah*, *C. limbatus*, *Scolidon palasorrhah* and *S. Walbecchmi* which have varied distribution in east and west coast. They also vary in different seasons.

The oils from the livers are extracted by employing a simple method. In this method the liver is collected from various sharks and the entire mass is heated till the oil is separated and set free. The oil thus collected is filtered and dehydrated with anhydrous sodium sulphate. The oil after refining is diluted to the required vitamin A potency by deodorized groundnut oil and enriched with synthetic vitamin D.

Development of rancidity, bacterial contamination and metallic contamination from containers exposure to light and air during extraction and storage may because destruction of vitamin A. Hence the livers should be rendered as early as possible after landing of sharks. Organic peroxides in the oil also affect the vitamin A content in stored oil. To protect vitamin A content, antioxidants e. g. isobutyl gallate (0.2%) + citric or tartaric acid (0.01%), O - Triacetyl - gallyl - phloroglucinaldehyde are used. Dilution with ground nut oil retards deterioration.

The freshly extracted oil is yellow, orange or brown in colour with mild fishy odour, and low acidity. The dilute shark liver oil is prepared by the addition of refined groundnut oil with vitamin D.

The fatty acid composition of liver oils varies indifferent species. The saturated acids in Indian fishes are 40% than that of elasmobranchs liver oils from foreign sources. The latter has 20%

unsaturated fatty acids like hexadecenoic, oleic, linoleic, linolenic, gadoleic and tetracos - 12, 16 - dienoic acids have been found from the fishes of Indian waters. Glycerides isolated from shark liver oil include linolenic - diclupano - donin, arachidonic - diclupanodonin, linolenic - arachidonic - clupanodonin, triolein etc.

### Body oils

The whole fish is processed to obtain the fish meal and the body oil. Commercially important oils include sardine, herring and salmon oils. The fish with rich oil content and low oil content are processed through wet and dry processes respectively.

In the wet process the fish is crushed to a pulp and cooked with steam continuously in vertical cylindrical cooker. The cooked material is pressed and oil along with a mixture of fish solubles known as stick water is drawn into settling tanks and later passed through centrifugals to separate the oil. The material after the extraction of oil is dried, powdered and marketed as fish meal.

In dry process, fishes with low oil content are processed as the oil recovery is low. The fillet waste and shark carcasses are disintegrated in a grinder and cooked under regular stirring in a cylinder heated by steam. The oil is then pressed out.

Raw oils have a disagreeable odour and taste. Through hydrogenation this can be eliminated or minimised. Free acids are neutralised by caustic soda and the oil is deodorized by superheated steam at reduced pressure and finally dehydrated by heating at 105 °.

Seasonal fluctuations in the oil content of different species have been observed. This variation may be related directly with availability of food. Presence or absence of the dinoflagellates and the copepods in the plankton has contributed to the variation in fat content.

The oil consisting of fatty acids and the glycerides after deodorization and hydrogenation are used for edible purpose. Oils with low iodine content are used in the preparation of laundry soap, cheaper grade toilet soap etc. Sulphonation, polymerization, saponification are the processes followed in getting an excellent quality soap. Fish oils are used in the leather industry in making leather flexible and impermeable to water. Oil with high iodine content is used in application of paint, varnish etc. Heat treated fish oils and destearinated fish oils mixed with driers are used in blends with lined or tung oil since it gives flexibility and heat resistant films.

The other important uses of fish oil are manufacture of candles, lubricants, cutting oils, cosmetics and pharmaceuticals, linoleum, rubber substitutes, water proofing compositions, printing inks and core oils. Oil containing vitamins are used in animal and poultry feeds. Fish oils act as fungicides when applied to citrus trees. Fatty acids of the oils are suitable for concentrating low grade iron ores.

### Sardine Oil

Sardine oil is extracted from *Sardinella longiceps* in the west coast and is considered as cottage industry. The large scale extraction of oil generally takes place between August and March. The collected fishes are put into the water bath with little water and heated for 30 to 45 minutes. The oil is set free from tissues and floats to the surface and is collected separately. The residual matter is put into the coir bags and pressed. The oil along with the water separates out and collected in tanks. The oil then floats to the top which is separated and filtered. The yield of oil is 10 - 15%. The residue known as guano is dried and used as manure.

Freshly extracted oil contains vitamin A (25% of oil present in cod liver oil) which is reduced during storage and is used for edible purposes. Technical grade oil is used for batching jute and dressing leather, as a lubricant, for insecticidal soaps, for tempering of metals, for painting bottoms of country boats.

After the extraction of oil the waste forms a source of several products and the economic utilization is not fully explored in our country. Some of the useful products which are obtained

through processing of shark carcass are edible muscle for pastes and puddings, fins and tails for soups, vitamins, carateucs and sterols. Similarly salmon cannery wastes are used in cosmetics, soaps, chemical industries, chocolates, pharmaceuticals, animal feeding, fish hatchery food etc.

#### 18.4.2 Fish Meal

The waste which is obtained after the fish is processed for extraction of oil is known as fish meal. The waste obtained from non oily types of fish of the cod industry is known as White fish meal. The fishmeal is prepared either by dry or wet processing depending upon the raw material. In dry method the meal is exposed to high temperature like sun, or in flame driers or in steam jacketed drums often under partial vacuum-Vacuum drying gives a superior product. The good quality fish meal is used as supplement in animal feeding. The other one is used as manure.

The chemical composition of fish meal has wide range in moisture 6-12, proteins 55-70, fat 2-15, and animal matter 10-20% or even more. The fish meal is considered as very rich source of proteins Also it is rich in calcium. 5-36%, phosphorous 3.42%, iodine etc. Some fish meal possesses vitamins A, D & K. Vitamin B<sup>12</sup> which promotes growth of animals is present in high concentration. It is also used as ingredient of feeds for farm animals. By using the fish meal as a supplement feed no harmful effect on the quality of milk from cows or on flesh of pigs and poultry are observed. Fish meal on an average contains the Vitamins (Vitamin B): thiamine 0.13, riboflavin 0.67, nicotinic acid 6.4, pantothenic acid 0.91, pyridoxin 1.4, choline 396.5 mg/100 gr. cobalamin (0.12 micro gram/g) and inositol (230 micro gram/g). The fish meal produced in the west coast is of inferior quality and is used as manure in coffee, tea and tobacco plantations. The fishes which are unfit for use as food are utilised as manure. Spoiled horse mackerel, mackerel and sardines are the example for use as manure. Fish manure contains N 5-7, P<sub>2</sub>O<sub>5</sub> 4-6, CaO 4-6%. Sometimes fish waste is buried in pits for 35 - 60 days, then dried and fermented in hot sun, such material is known as pit for 35 - 60 days, then dried and fermented in hot sun, such material is known as pot manure and fermented contains N 3-5, P<sub>2</sub>O<sub>5</sub> 2-6, and CaO 1-5%. Fish guano contain 8-10%N.

The fish meal is usually stored in gunny or coir bags as they are insect and vermin proof. The tin containers under an atmosphere of nitrogen with soldered lids are also employed for satisfactory storing. The annual production of dry fish manure is about 1.5 lakh md. It is mostly produced from Karwar to Cape Comorin.

#### 18.4.3 Fish Flour

Fish flour forms an ideal protein supplement to human diets. Infants meal fit for human consumption. It is prepared by solvent extraction process on a commercial scale. This can be blended with wheat or maize flour and is used as enriching component in bread, biscuits, cakes, sweets, soups and gruel. The taste and appearance of bread remains unaltered when the fish flour is added upto 10% level.

#### 18.4.4 Fish Silage

The fresh fish is mixed with sulphuric acid, formic acid or a mixture of sulphuric acid and molasses resulting in the formation of semi stuff. This silage is preferred over fish meal since the vitamins are not affected and do not produce fish odour.

#### 18.4.5-Fish Solubles

The residue liquor (stick water).from fish oil plants and carneries is known as condensation of fish solubles and considered as additives to dry feeds for animals. The fish soluble is rich in soluble proteins, protein degradation products and vitamins of B. complex. It contains water 50.0, crude protein 33.9, fat 2.6, and ash 9.4%. Vitamins: thimine 4.0, riboflavin 20.0, nicotinic acid 32.5, calcium pantothenate 40.0, biotin 0.14, pyridoxin 0.0125, and Vitamin B<sub>12</sub> 0.3 ug. The

various amino acids like arginine, histidine, lysine, tyrosine, tryptophan, phenylalanine, methionine, threonine, leucine, isoleucine, valine which varies differently in fish flesh, fish meal, fish egg etc. are present. This is easy to handle and store and is incorporated into the rest of the process to produce whole fish meal or dehydration into powdered form.

#### 18.4.6 Fish Protein

The proteins of the fish have high digestibility, biological and growth promoting value. Hence it plays an important role in human nutrition. The available amino acids are more evenly balanced than the other proteins of animal origin. Amino acids like lysine and methionine are rich in fish protein. In general fish protein is somewhat superior to egg albumen, bean protein and casein and perhaps equal to chicken proteins.

15-25% of protein is obtained from the fish muscle which forms the chief source. About 95% of available protein can be obtained by using sodium chloride solution. The proteins present in the cells i. e. intracellular consist of myosin 66-75%, myogen 6%, myoalbumin 7%, globulin 8% etc., along with collagen and elastin contributing to stroma proteins together with crude protein of 3% of total proteins, and other proteins including nucleoproteins and haemoglobins.

The fish proteins are extracted with dilute caustic soda solution from fish fillets or waste after removing the fat. The extracted material is dried after neutralization. This powder is white in colour without any fishy odour and taste containing 80-90% of solubilized protein. This is used as a substitute for white of the egg in baking, confectionery, ice cream and pharmaceutical products. This is also used in paint, varnish, textile, paper, cosmetics, moulding powders and foam type extinguishers.

Hydrolyzed fish protein can be extracted from the flesh of Indian sharks and rays. The 85% of protein content, a cream coloured product is obtained in a yield of 10% of the raw material. It is easily soluble in water and has greater whipping power than that of egg albumen and good keeping quality.

#### 18.4.7 Shark Fins

The fins of the large sharks except caudal fin are cut near the root, washed in seawater, mixed with wood ashes and lime and dried in the sun or smoked. This product which is crisp and brittle are used in soups and regarded as delicacy in China and Phillipines.

#### 18.4.8 Fish Eggs, Fish Roes

Fish roe is a good source of vitamins B, C, D and E in addition to various amino acids present. viz. thymine, citruline, creatine, taurine, tyrosine, xanthine and hypoxanthine. Fish roe fat possesses high lecithin (59%) and cholesterol (14%). Roe protein colourless and tasteless with digestibility coefficient and biological value at 81 and 88% respectively. It is used in various food products and for the manufacture of glue and synthetic fibre.

#### 18.4.9 Fish Glue

Fish glue is prepared from skins, trimmings and bones. The material after washing is mixed with small quantity of acetic or any strong acid and cooked for 6-10 hours. Later the residue and the liquor are separated.

It is used as a strong and flexible adhesive such as in the manufacture of court plaster, backing for labels and stamps, book binding etc.

High quality fish glue obtained from the skin is useful in photoengraving work. Inferior quality glue is used as adhesive in the manufacture of paper boxes, furniture, repairing of shoes and general joining work.

The residue known as chum is dried and used as feed or fertilizer and contains moisture 12.0, protein 53.0, fat 1.5, crude fibre 0.8, calcium and magnesium phosphates 27.0 and other constituents 5.7% and is considered as poultry feed.

#### 18.4.10 Isinglass

Isinglass is high grade collagen produced from air bladder or swim bladder of fishes like cat fishes and carps. The air bladder consists of outer thick and fibrous layer while the inner layer is thin with a silvery lustre. The inner layer consisting of isinglass is dried and marketed under different trade names purse or lump, leaf or honey comb, book and ribbon etc.

Isinglass is insoluble in cold water and hydrolyses to a gelatinous substance with adhesive properties when heated with water.

Isinglass in earlier times is used as substitute for gelatin in confectionery. now it is mainly used for clarification of wines, beer and vinegar. It is also used in the preparation of plasters and special cements.

Excellent quality of isinglass can be had from the fishes like salmon from Bombay, Madras and Sunderbans. While the inferior quality of isinglass can be prepared from the fishes like jew fishes and catfishes from Kerala.

#### 18.4.11 Fish Skins

Fish skins have varied uses. The skin of the large fishes such as sharks and rays are first detached from the flesh and soaked in brine for 24 hours. Later the skin is removed and drained, salted and soaked in salt solution alongwith 10% hydrochloric acid. After draining once again the skin is scraped and the dactides are removed. Then it is tanned and marketed as ornamental leather which has pleasing appearance and is pliable and durable. It is used in the manufacture of shoes, hand bags, wallets and tobacco pouches. The skin can also be dyed to desired colour.

---

## 4.12 STEROLS

---

Among the unsaponifiable fraction of fish oils cholesterol which produces vitamin D<sub>2</sub>, squalene which is used in the dyeing of synthetic fibres are present. Lecithin in shark and dog fish oils, in the oil of fish eggs are present in high concentrations and is used as wetting agent and antibloom agent in the chocolate industry.

Thus the various by products obtained from the body of the fish or from important organs of the fish have a greater food value in human nutrition. By adopting the various methods, the by products rich in proteins, minerals, enzymes, vitamins etc. can be had from the fish. These by products are important since the various industries use them in the preparation of cosmetics and pharmaceuticals also.

#### Check Your Progress

1. Fish Silage
2. Fish Glue.

---

## 18.5 SUMMARY

---

The various by products which can be obtained from fish, such as fish proteins, Liver Oils, Body Oils, Fish Meal, Fish Flour, Fish Skins, fins, eggs, Isinglass, their preparation, uses are described here. Fish is a rich source of proteins and Vitamins. Apart from these two it yields a very large numbers of by- products which will be very useful to manure discussed here.

---

## 18.6 CHECK YOUR PROGRESS - MODEL ANSWERS

---

1. The fresh fish is mixed with Sulphuric acid, formic acid or a mixture of Sulphuric Acid and molasses resulting in the formation of senu solid staff. This silage is preferred over fish meal since the vitamins are not affected and do not produce fish odour.
2. Fish glue is prepared from skins, timings and bones. They are marked after washing is mixed with small quality of acetic or any strong acid and cooked for 6-10 hours. Later the residues and the liquour are separated.

---

## 18.7 MODEL EXAMINATION QUESTIONS

---

### I. Answer the following in about 30 lines :

1. Explain in general the chemical composition of fishes.
2. Briefly explain how the oil is extracted from the liver of the fish.
3. Explain in brief about the composition and uses of cod liver oil.
4. What are the important uses and the composition of shark liver oil?

### II. Answer the following in about 10 lines :

1. What are the nitrogenous constituents present in fish muscle?
2. What is fish meal? Mention the different uses of fish meal.
3. What are the uses of fish proteins?
4. How is sardine oil extracted and what are its chief uses?

BRAOU

---

# UNIT-19 CRAFT AND GEAR

---

## Contents

- 19.1 Objectives
- 19.2 Introduction
- 19.3 Fishing Craft
  - 19.3.1. Indigenous Craft
  - 19.3.2. Coracle
  - 19.3.3. Sangadam
  - 19.3.4. Shoe Dhori
  - 19.3.5. Catamaran
  - 19.3.6. Tuticorin
  - 19.3.7. Dugout Canoe
  - 19.3.8. Out rigger Canoes
  - 19.3.9. Masuls Boat
  - 19.3.10. Built-up Boats
  - 19.3.11. Nava
  - 19.3.12. Dingi and Nauka
- 19.4 Mechanisation of Fishing Craft
- 19.5 Out board
- 19.6 Inboard Motors.
- 19.7 Materials used for construction of Fishing Craft
- 19.8 Model Sheathing the Underwater portion of the pull.
- 19.9 Metallic Fittings
- 19.10 Protection of the Boat
- 19.11 Fishing Gear
  - 19.11.1. Disabling Type
  - 19.11.2. Traps and Barriers
  - 19.11.3. Filtering Type
  - 19.11.4. Entangling Type
  - 19.11.5. Self Fishing Type
  - 19.11.6. Shore Seines
- 19.12 Common Fishing Gear for Inland Waters
- 19.13 Gear for Spawn collection
- 19.14 Mesh size, Thread and weaving

- 19.15 Gamcha
- 19.16 Materials used for Fishing Gear
- 19.17 Preservation of Fishing Gear
- 19.18 Summary
- 19.19 Check Your Progress - Model Answers
- 19.20 Model Examination Questions

---

## 19.1 OBJECTIVES

---

This unit deals with the different fishing craft and fishing gear used in both marine and inland waters.

After going through this unit you learn about

- (1) mechanization of fishing craft,
- (2) the gear applied for spawn collection
- (3) the methods of protecting the fishing crafts and
- (4) the materials used for fabricating the fishing gear and its preservation.

---

## 19.2 INTRODUCTION

---

In recent years, the total fish production has expanded from 52.4 million metric tons in 1965 to 75 million metric tonnes and this increase in production is possible due to three main technological revolutions, i.e., (i) mechanisation of fishing craft (ii) use of synthetic fibres for fabricating the fishing gear and (iii) electronic equipments for fish detection and location. Modern fishing gear by synthetic fibre plays an important role to increase the production through exploitation from marine and inland resources. However, in recent years, much progress has been registered towards evolving new methodology and tools of the trade.

---

## 19.3 FISHING CRAFT

---

The fishing vessel, with its equipment, forms an instrument evolved to fulfill a function, as efficiently as the knowledge of its builders permit. Fishing methods are the basic controls of the types of craft used. The basic aim of fishermen is to use the method giving the greatest catch per unit effort. The great revolution in recent times is the mechanisation of fishing/craft.

### 19.3.1. Indigenous Craft

Particular designs of craft have evolved according to particular local conditions and are confined to definite areas. The coracle, Sangadam, Shoe dhoni, Catamaran, Tuticorin boats, Dugout canoes, Plant built canoes, outrigger canoes, Masula boat, Built up boats, Nava, Dinghi and Nauka are some of the indigenous craft used.

### 19.3.2 Coracle

It has a frame work of bamboo wick work, usually a large wide mouthed (12 feet diameter) circular basket, much flattened vertically and made water tight by a covering of hide. It is mostly used for fishing in rivers and reservoirs.

### 19.3.3 Sangadam

It is a curious palmyra dug-out, often used double. Sections of palms are hollowed out on one side and two of them are lashed together parallel, by bamboo poles. The end of each dugout is bulbous and wide, the other is narrow and wide.

### 19.3.4 Shoe Dhoni

A Sangadam copied out in planks, with a keel below fore end, gives a Shoe dhoni. It is wide and flat forward, with a sharp stem; it narrows greatly after and has a square transom stern. An oar is used for sculling, when there is no wind; a lofty square sail, from a bamboo yard on a mast is used with wind on. Narrow teak planks are used for the hull nailed on ribs of any wood. They are very suitable for fitting out board motors.

### 19.3.5 Catamaran

It is a keelless raft formed by rigging together several logs which are curved and shaped like a canoe. One end of the craft is shaped into a cone rising above the water, forming the stem from where the rudder is used. The use of Catamaran is restricted to east coast from Orissa to Cape Comoring with a short extension northwards on the Kerala coast. Four types of Catamarans are known viz Orissa and Ganjam type., Andhra type, Coromondal type and Boat catamaran.

- i) Orissa and Ganjam type: It is made up of five logs which are not tide together by rope but are pegged with wood; it is boat shaped.
- ii) Andhra type: It is larger than the preceding type and made of heavy wood. Planks used in fitting the sides often include strong median logs.
- iii) Coromondal type: It is made of 3-5 logs, with many variations in pattern. It is most commonly used around Madras.
- iv) Boat Catamaran: It consists of three logs fitted into a regular boat shape and is used on the coast around Mandapam and Mukkur areas. Wide variations of this type are found in the Tuticorin, Cape Comorin and Colachel areas.

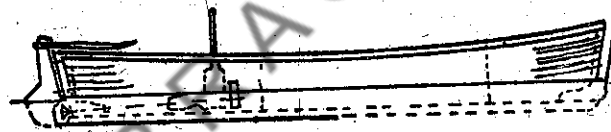

Fig. 19.1 Tuticorin Boat

### 19.3.6 Tuticorin Boats

Also called the fishing luggers, they are carvel boats (11m x 2m x 1m) which are sea worthy in inshore waters. They are used more as mother ships and cargo boats than directly for fishing.

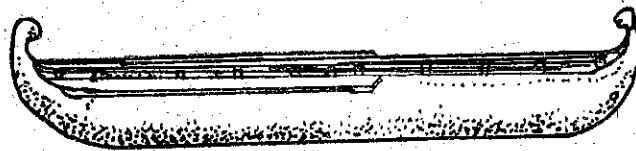

Fig. 19.2 Dugout Canoe of Malabar

### 19.3.7 Dugout Canoe

These are made from logs of wood by scooping out the inner part the keel portion being thicker than the sides. These are mainly used on the Kerala and Kanara coasts and also between Colachel and Kathiawar and N.Bombay.

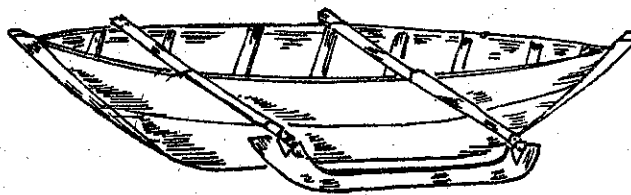

Fig. 19.3 Outrigger Canoe of Karwar

### 19.3.8 Outrigger Canoes

They are built up canoes with a narrow keel, but differ from the plant built canoes in that the planks are more spread out. They are usually operated on the Kanara and Konkan coasts for mackerel operations.

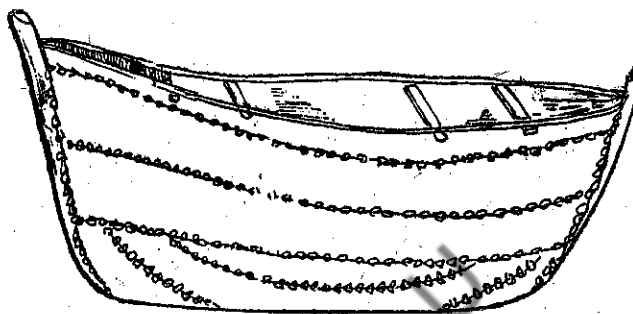

Fig. 19.4 Masula Boat of Andhra coast

### 19.3.9 Masula Boat

It is a non-rigid boat constructed with planks, sewn together with coir rope, but without frames or ribs so as to withstand the severe knocking of the surfs. There are various patterns viz. bar boats in Orissa, padava or padagu on the Andhra coast. A variant with ribs inside has been developed in the area between Kakinada and Machalipatnam.

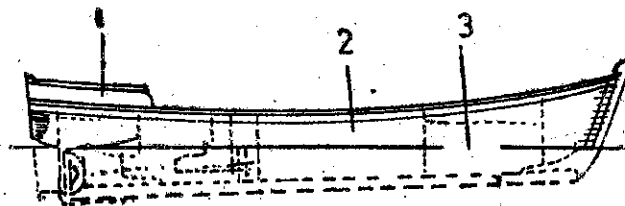

Fig. 19.5 Built Up Boat of Saurashtra  
1. Stores 2. Nets 3. Fish room

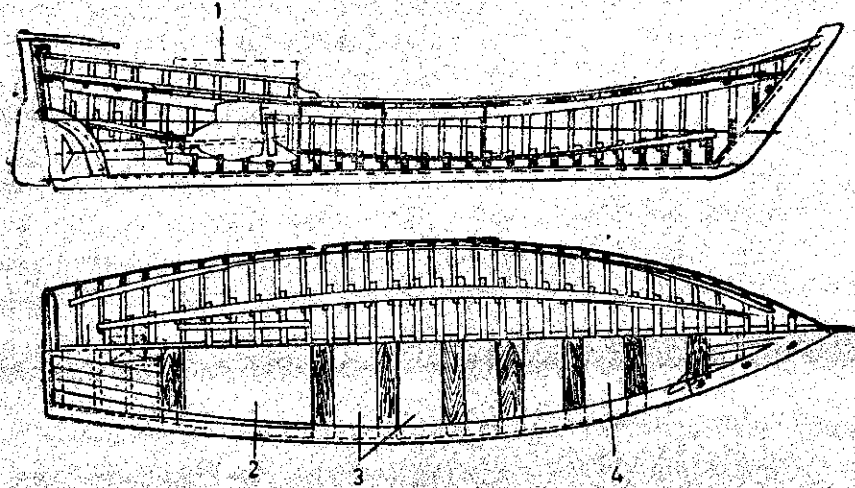

Fig. 19.6 Satpati Type of Boat 1. Frame for sail cloth over engine 2. Motor compartment 3. Fish 4. Nets.

### 19.3.10 Built up Boats

The best type of constructed, indigenous boats are seen on the west coast, north of Ratnagiri and along the Bombay-Cambay coast. The Ratnagiri type has a pointed bow, straight but narrow keel and low gunwale. The Bassein type, locally called machwa, has a broad hull, pointed bow and straight keel. The Satpati type, popularly called galhat, has a medium pointed bow, broad beam, straight keel and high gunwale. The Broach type is flat bottomed and used in in shore and esturine waters. Built up boats, particularly the Satpati type, have become popular as they can be mechanised without any alteration in design.

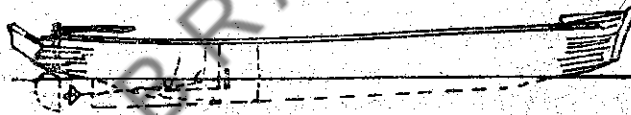

Fig. 19.7 Kakinada Nava



Fig. 19.8 Masulipatnam Nava

### 19.3.11 Nava

The nava is a striking example of the ingenuity of the local boat builders in developing boats for difficult shallow water conditions. It has a shallow draught and is very narrow, keelless sailing boat, built without much variation-31'10" long, 5' bread, 2'4" deep and tonnage of 2.7. The keelless rocked bottom, with round bilges is excellent for navigating by sail, paddles or poles through shallow back waters and muddy passages. Made out of teak, with heavy frame and longitudinal strings, in three or four places, on each side. It is also strong enough to land, with full lead, on hard beaches, even through surf. It has carvel planks, with a short fore deck and longer after deck and has been found suitable for mechanization. This type of boat is widely used in Andhra coast especially in and around Kakinada.

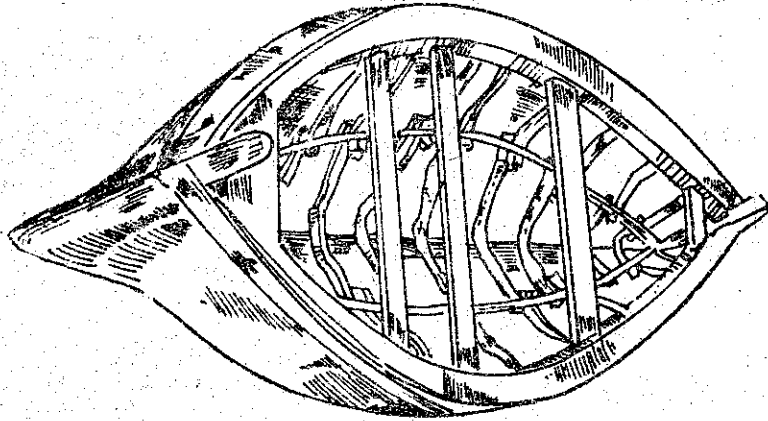

Fig. 19.9 Dinghi-A carvel Boat of N.Orissa

### 19.3.12 Dinghi and Nauka

These are carvel boats of Orissa and West Bengal. Naukas which are well designed and constructed upto a size of 13m x 3m x 2m are quite specious and are used for a variety of purposes including fishing operations.

---

## 19.4 MECHANIZATION OF FISHING CRAFT

---

Installation of engine for propulsion of fishing craft and the use of mechanical devices for handling fishing gear is termed as mechanization. The advantages to the fishing industry by mechanization of fishing craft are:

- (i) to take crew safely and comfortably into the farther waters of the fishing grounds and to allow them to stay there for following and catching shoals.
- (ii) to allow the use of better and more powerful nets and lines.
- (iii) to save time, increase freedom of action and to permit use of mechanical appliances to save labour and increase efficiency.
- (iv) to enable steps to be taken by fishermen to ensure proper preservation of fish from taint, from place of catch to shore.

The first problem in mechanization programme is the selection of a proper engine. There are so many types and kinds, each with its own advantages and disadvantages.

---

## 19.5 OUT BOARD MOTORS

---

Most types are made for use in pleasure boats, they are light and the R.P.M. are too high for efficient use in heavy fishing boats. But new models for heavy duty are now available with under water parts of bronze and with long vertical shafts to facilitate use on fishing boats. It does not require an engine bed or a stem tube installation. It can be removed in favourable wind, taken home after work. But the high cost of petrol and the delicate mechanisms of the engine are handicaps. Of late, diesel out boards are also being offered.

---

## 19.6 INBOARD MOTORS

---

### Gasoline Engines

Modified car engines. They are easy to maintain, cheap, low weight and easily available. But fuel is costly, highly inflammable and so these engines can be avoided in fishing boats.

### Kerosene Engines

They are converted car engines with a separate carburetor for kerosene. They are small, light weight and easy to maintain, the cost of fuel is not much but are not heavy duty.

### Semi Diesel Engines

These are heavy duty, slow running oil engines, mostly of the two cycle type, containing very few moving parts. These engines are heavy, bulky and vibrate much and so can be used only on strong boats.

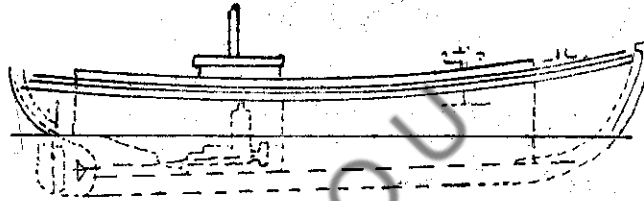

Fig. 19.10 Pablo type Fishing Boat of Tamilnadu with Engine

### Diesel Engines

Diesel engines are considered the best for fishing boats. But they work under very high pressure and the parts are so delicately precise that only trained and experienced mechanics can deal with them; the initial price is high and they require high grade oil, which is costly but they have low fuel consumption per horse power.

---

## 19.7 MATERIALS USED FOR CONSTRUCTION OF FISHING CRAFT

---

The cost of a mechanised fishing boat excluding the engine, gear and gear handling equipment is determined by timber used for construction of this hull, type of metal used for sheathing the under water portion of the hull, and types of metallic fittings. These together account for 45 to 50% of the total cost of a boat ready for fishing.

### Timber

Indian timbers most suitable for all construction purposes are teak (*Tectona grandis*), sal (*Shorea robusta*), paduk (*Pterocarpus dalbergioides*), gurjan (*Dalbergia latifolia*), bijasal (*Pterocarpus marfupium*) and aini (*Artocarpus hirsuta*). The wood used for construction of fishing boats should be strong, moderately heavy, durable and of good bending property. It should withstand heavy duty under strenuous fishing conditions and behave well under alternate wetting and drying. Teak and aini remained to be the conventional timbers for fishing boat construction

met these quality requirements. A number of timber varieties were examined as substitutes for teak and aini and as a result of the investigations ventek wood (*Lagerstroemia lanceolata*) has been found to be a very satisfactory one for building boats at a cheaper cost.

---

## 19.8 METAL FOR SHEATHING THE UNDERWATER PORTION OF THE HULL

---

The portion of the hull below water is protected with a sheathing of copper plates of the desired thickness and quality. This method of hull protection has been very effective under normal working conditions. But the requirement of copper in the country is mostly met by import because of the limited indigenous resources. Aluminium-magnesium alloy (with 2% magnesium) proved as a satisfactory sheathing material. The alloy is light, resistant to sea water corrosion and cheap in price. Fouling on the metallic surface can be eliminated through the use of specific painting schedule comprising etching primer, barrier coats and antifouling paints and such coats should be renewed once a year without fail. To ensure satisfactory performance and long life of the sheathing, specifications of materials and different types of surface coatings recommended must be strictly followed. Due to high price of copper, replacing copper with the aluminium alloy, results in a good saving of foreign exchange as well.

---

## 19.9 METALLIC FITTINGS

---

Boat fastenings constitute yet another source of heavy expenditure in fishing boat construction since the nuts and bolts, rivets, screws and washers used are all made of costly copper. Similarly, the heavy stem band and keel shoe fittings have been made of non-ferrous castings at a very high cost. Iron structures with a tough surface coating of zinc, otherwise called galvanised iron structures, have been found to last longer when used both above and below water line of a fishing boat. The surface coating of zinc or iron when worn out can be renewed by zinc chromate paint after careful surface preparation. Thus at a little extra cost the normal life of ferrous fittings can be considerably enhanced.

Experience with cast iron fittings in a fishing boat has shown encouraging results with respect to their overall performance. Their cost is 1/5th to 1/6th of brass and bronze castings. It is also found that for every 3 kg of copper tacks required for the fixing up of copper sheets on the hull only 1 kg of aluminium alloy tacks would be required when used with aluminium alloy sheathing.

---

## 19.10 PROTECTION OF THE BOAT

---

The life of a boat depends as much on the use of good material and workmanship in the construction, as on the maintenance of the hull. The most common enemy of wood is decay or rotting caused by vigorous fungi. Paint helps to prevent the weathering of wood and entrance of moisture into the cells of wood. The action of marine borers and other ship worms can cause great damage to underwater parts of the boats in salt water in the tropics. The use of copper sheathing and copper paints on the bottom can prevent the entrance of the worms into the hull. In view of high cost of copper sheathing, aluminium-magnesium sheathing can also be used to protect the under water portion of the hull. Anti fouling paints are the cheapest, as they not only prevent the growth of barnacles and grasses, but also discharge the entrance of worms.

---

## 19.11 FISHING GEAR

---

Von Brandt has classified fishing gear into 13 categories taking into consideration the various fishing gear and techniques from the different parts of the world. These 13 categories of fishing gear are included under the following five main types;

1. Disabling type
2. Traps and barriers
3. Filtering type
4. Entangling type
5. Self fishing type

### 19.11.1 Disabling Type

This type of fishing gear are wounding gear, stupefying gear and hooks and long lines. The fundamental principles underlying different disabling type of fishing technique are luring, attacking and snaring or a combination of these. Laces, clamps, rakes and tongs are weapons used by man of the past ages. Harpoons and rifles were also used to be thrown by hand or equipment. Poisons like endrin, barringtonio, Derris powder etc. are used to stupefy and kill fish. Electrical fishing is the recent development in catching fish by stupefaction. In case of line fishing, the principle used to offer the fish a real or artificial bait to entice to bite. Various forms of hooks and gear are made for angling different kinds of fish. Following are the types of disabling gear.

### Fishing without Gear

This is primarily a method of hand picking. Sometimes baskets or small tools for gathering fishes are also used which are not considered as gear. Fishing by feet is also another method. Diving is a general practice. Trained birds or animals are also used.

A casual stroll along the backwaters of Kerala and Cochin in particular will give the common sight of ladies crawling along the shallow water with an earthen ware pot floating. This represents the hand picking of prawns. Sometimes they even use 2 sticks by which they encounter the fish keeping it to form an angle at the bottom. Similarly, the rocky area and jetty sites people collect molluscs with chisel and knives. Diving for molluscs is also a common practice.

### Stupefying methods

These include the under water explosion. Poisoning with ichthyotoxic plant preparations mentioned above and by electric current. Stupefying methods are common among the tribals especially along the Nicobar coast where they use some herbs for stupefying fishes. This type of fishing is also reported from the tribals of Assam and the like.

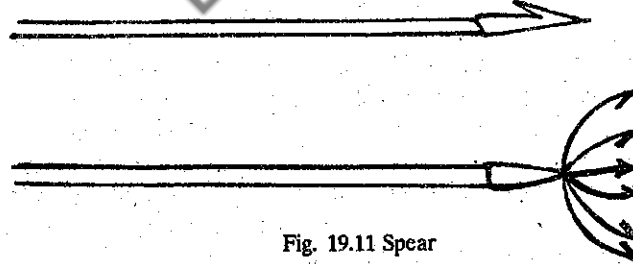

Fig. 19.11 Spear

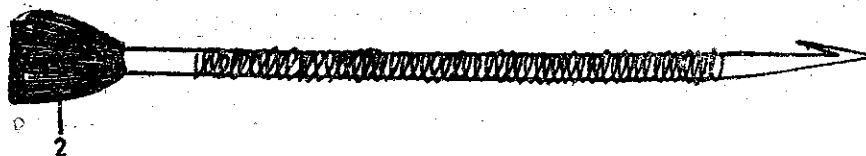

Fig. 19.12 Blow Gun harpoon Dart 1. Line 2. Barbed steel head

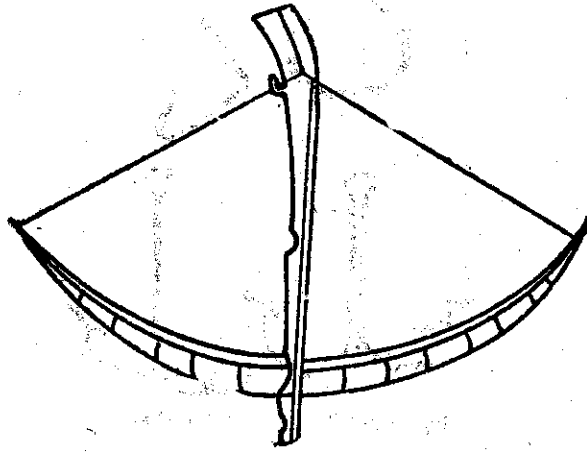

Fig. 19.13 Cross Bow

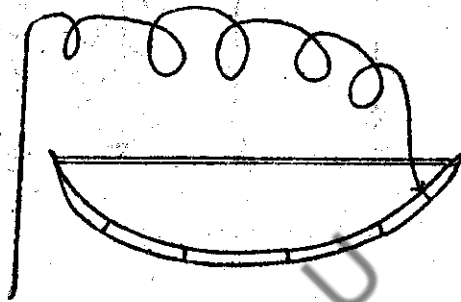

Fig. 19.14 Pellet Bow

### Wounding Gear

Spears, harpoons of different types, so also clamps, tongs etc. and guns form the devices.

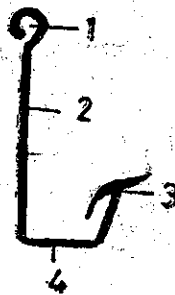

Fig. 19.15. A Fishing Hook  
1. Eye 2. Shank 3. Point with Barbs 4. Bend

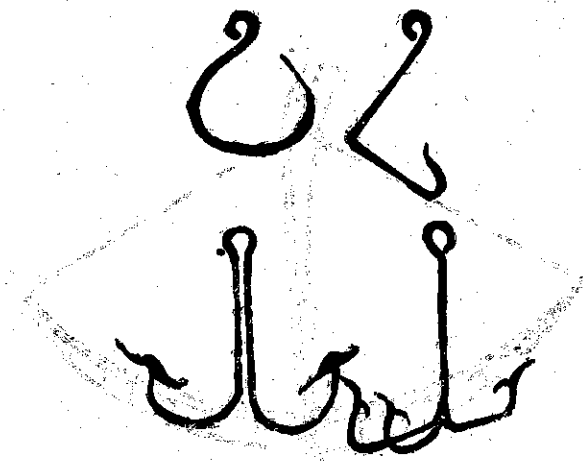

Fig 19.16 Different Types of Hooks

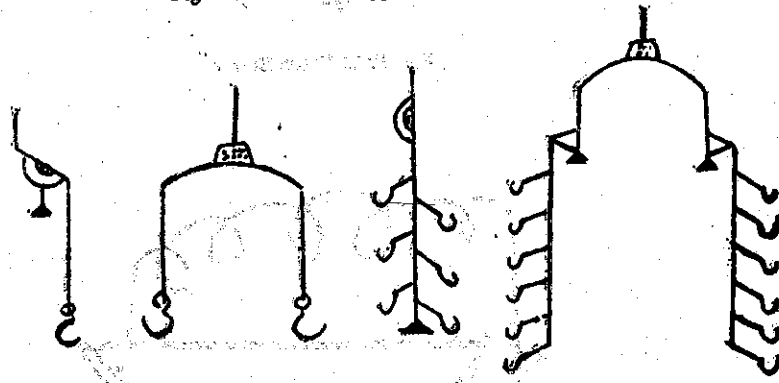

Fig-19.17 Long Lines with Several Hooks

**Limes**

lines can be with or without hooks. The main principle in this method is to offer a real fish or artificial bait to entice the fish to bite. Different types of lines are cast lines, hand lines, pole and line, set and drift lines and troll lines.

**19.11.2. Traps and Barriers**

Catching principle is based on one entry of the fish into the trap attracted by bait or without bait from which the fish cannot escape. Several types of barriers are used in fishing by bailing out water from shallow water impoundments and groping in the mud with bare hands to capture fish. The most common fishing by this type of gear intercepting barriers and stream weirs.

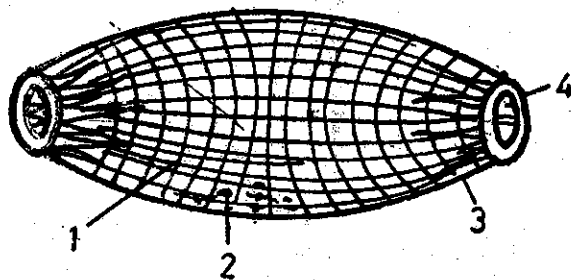

Fig. 19.18 Basket Trap

1. Basket 2. Food 3. Recurved sticks 4. Opening

## Traps

Trap is a place to which the fish is lured by a bait or attracting device and caught by special arrangements. Traps can be natural or artificial reefs bundles of brush wood, tubes etc. or mechanical traps like gravity traps, box traps, torsion traps etc. Some of the marine traps are lobster traps, kalava traps etc., artificial reef for flying fish. inland traps include traps for prawns, fish barrier, buoyed traps, raft traps, verandah nets etc.

### 19.11.3 Filtering Trap

The most important types of fishing gear fall under this class. Dip or light net, falling nets, bag nets, seine nets and encircling nets are some of the important and popular gears commonly used in inland and marine waters. In dip net operation the net is kept submerged horizontally and wandering or feeding fishes are lifted out by rapid operation of the net. On the other hand, a cast net is thrown on the surface water and in the process, the fish within its area are entrapped in the water column and get collected in its pockets. A bag net, totally or partially framed mouth is kept open by are trawl net and seine net whose operation is more elaborate and covers larger water column. Dragged gear which are commonly used in inland waters are dragged through the waters as a vertical screen, driving the fish into the belly and latter hauled out of water.

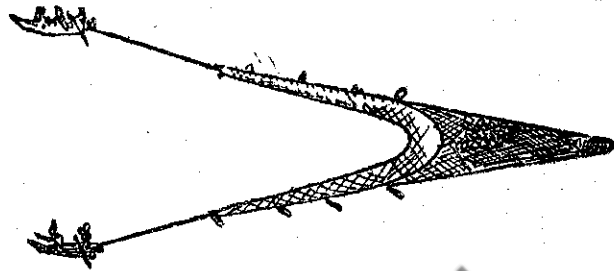

Fig. 19.19 A Bag net of Tamilnadu Coast

## Bag Nets

Bag nets are totally or partially framed mouths which can be fixed or mobile. The opening of the mouth of the net is checked by the water flow and fishes are filtered. The most developed bag net is otter board stow net. Other examples are scoop nets, push nets, drag nets, scrape nets, gape nets etc.

## Dragged Gear

These are nets towed through water. Eg. Rakes, dredges, trawls etc.

## Trawl Net

A trawl is a drag net, a large bag net tapering from the mouth, forming a flattened cone, with some device for keeping the mouth of the net open, while it is dragged over the bottom, or in

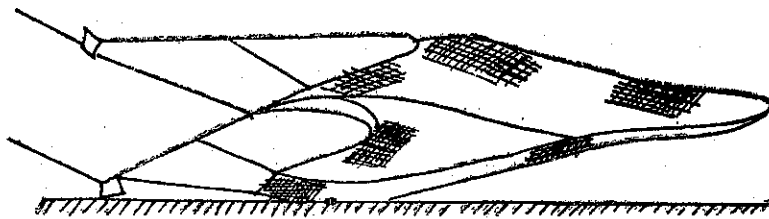

Fig. 19.20 Mid Water Trawl

mid water. Dragging such a net is trawling and boats doing so are called trawlers. The various parts of the net are head rope, foot rope, bridles, warp, dan-lence, cod end, ground cable or sweep, legs or leg line, rib lines, wind, square, jibbs or wedge, belly, throat, flapper, otter boards.

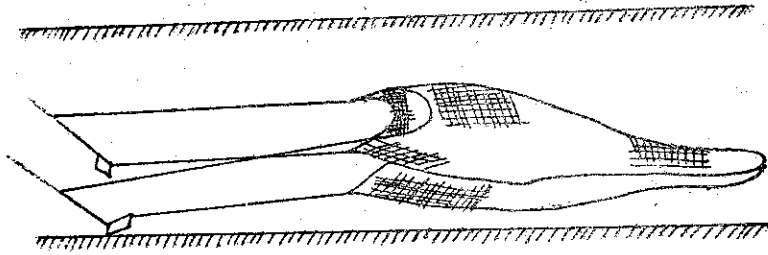

Fig. 19.21 Semi Pelagic Trawl

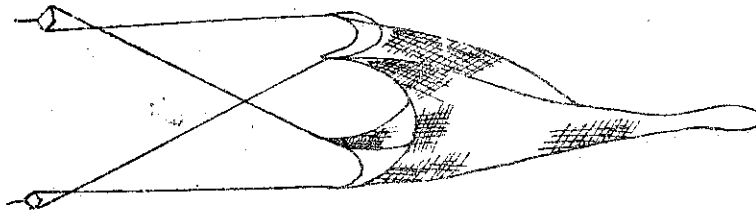

Fig. 19.22 High Opening Bottom Trawl

The different types of trawling are: (a) Beam trawl, (b) Bull trawl (c) Otter trawl. Otter trawl which is very common is of three types viz., Mid water trawl, Semi pelagic trawl and High opening bottom trawl.

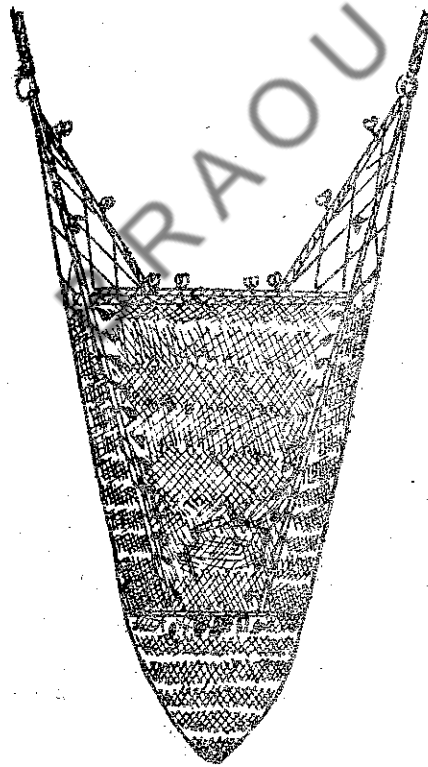

Fig. 19.23 A Boat Seine of Kerala coast

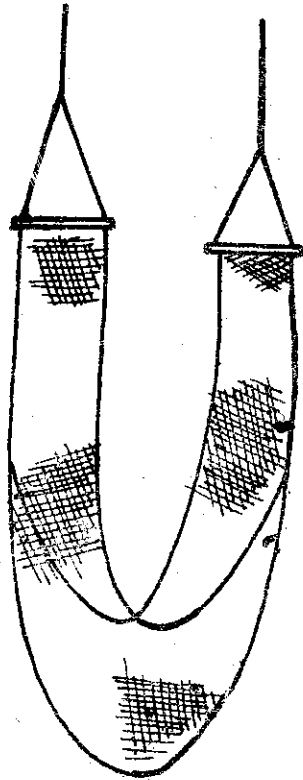

Fig. 19.24 Seine net without Bag

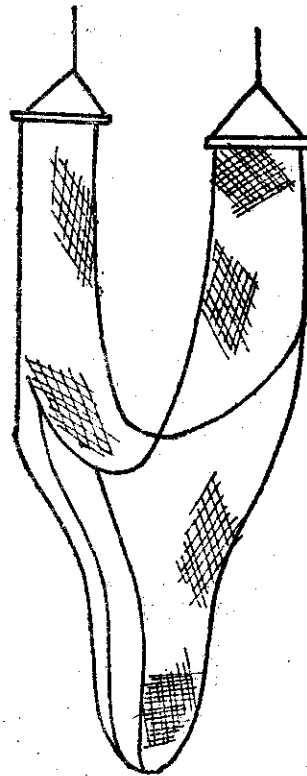

Fig. 19.25 Seine net with bag

### Seine Nets

Here one end of the net is shot from a fixed point to cover an area and then turned to the starting point where the gear is hauled up. The starting point can be shore or boat seine nets. This can be with or without bags.

### Surrounding Nets

Here a fish shoal is enclosed and scooped. The best known examples are ring nets and purse seines.

### Purse seine

The essential feature of this net is the pursing, by pulling a draw - string, which is threaded through a series of rings, along the bottom of the net below the lead line, so that, the lead line is puckered or bunched. This closes the bottom of the net and impounds the catch before the crew begin to pull in the net aboard the fishing boat. There are different types of purse seines viz purse seine with two boats, Deck purse seine, Lampara, Ring net, Beach seine, Boat seine and Danish seine.

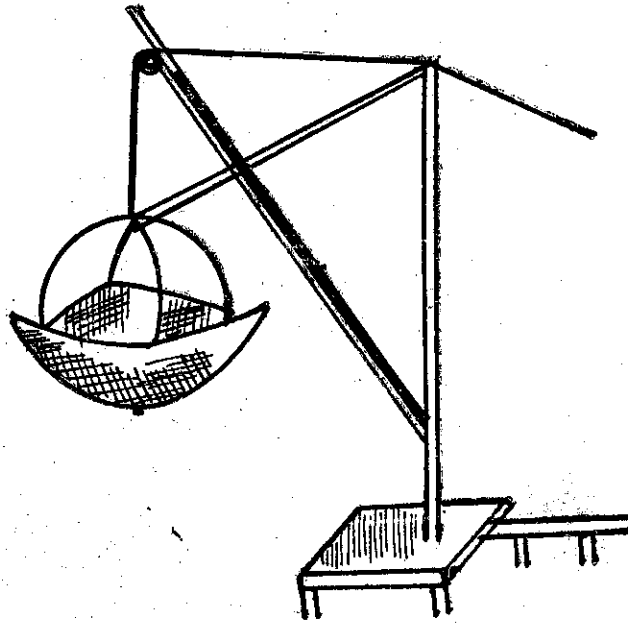

Fig.19.26 Lift Net

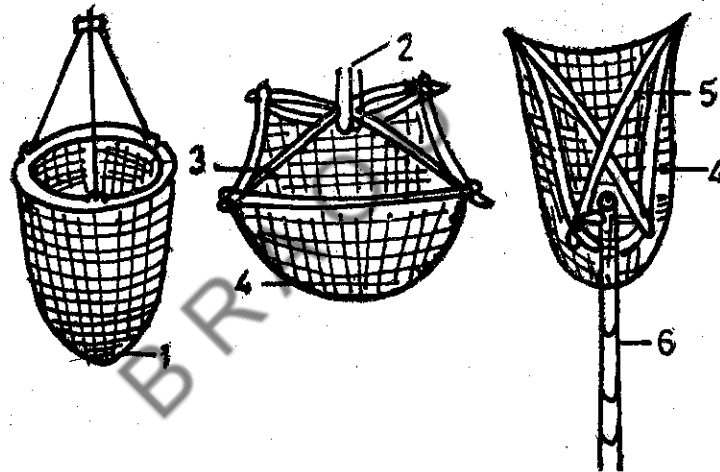

Fig. 19.27 Different Types of Lift Nets

1. Bag 2. Rope 3. Bamboo Stick 4. Net 5. Stick 6. Bamboo Pole

### Dip Nets

These include all types of nets which are lowered down and lifted up from the bottom, called either dip or lift nets. Eg Chinese dip net. The other examples are fish wheels.

### Falling Nets

This type of gear falls over the fishes and cover them. This includes cover nets, cast nets etc.

### 16.11.4 Entangling Type

The principle of capturing fish by this type of nets is based on their fortuitous encounter with

the nets. Nets are operated either as drift nets or kept stationery by anchoring in mid water or at the surface. Single wall gill nets and multi wall tremmel nets are of this type which are commonly used in nie and marine waters.

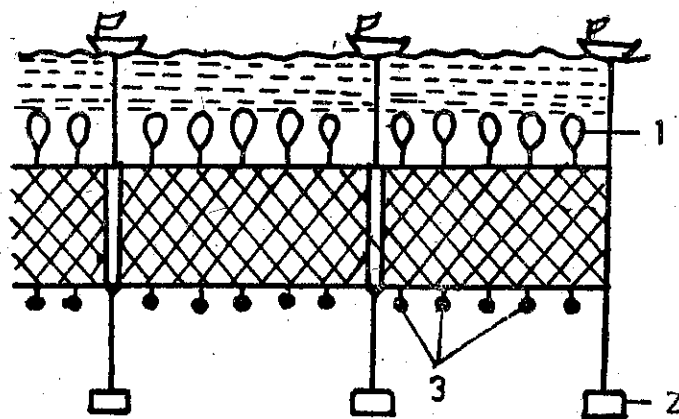

Fig. 19.28 A Floating Gillnet  
1. Floats 2. Anchor 3. Sinkers

### Gill nets and Tangle Nets

These nets hang in a more or less vertical position in water and are either set or drift with the current.

In true gill nets, fish are caught behind the gills by the meshes. The mesh size is such, that the head can pass through but not the body; when the fish tries to escape, it opens the gills and gets caught at the gills. So mesh size is very important. The webbing has to be hung well open and has to give enough resistance to the fish swimming into it, so as to allow the head to pass through. The gill nets are of different types viz. Bottom drifting, Bottom set, Surface drift and trammel nets.

### 19.11.5 Self Fishing Type

This type of fishing depends upon the physiological reaction of fish to physical or chemical stimuli engendered by the gear itself. Odour, sound, light etc. are main stimuli to attract fish of certain behaviour. Artificial obstacles such as a fish hedge or net wall are built to make the fish jump. A horizontal floating net, raft trap or even a boat or box can be used to catch the fish which get effected by the stimulus.

### Traps for Jumping Fish

Certain fishes jump out of water when excited or in danger. Making use of this behaviour artificial obstacles such as hedges, walnuts etc. are made to make the fish jump and it is then collected. To cite a few examples are salmon traps, boat traps, verendah nets, scoop nets, pit fall traps etc.

### Common Marine Fishing Gear

The fishing in seas is mostly done by nets of various sizes and designs. Besides, lines and hooks are employed for catching large fishes offshore. The main types of nets are fixed or stationery nets, bag nets, boat seines, shore seines, drag nets, drift nets, trawl nets, gill nets and cast nets.

Fixed or stationery nets are widely used all along the coast from Bengal in the east to the southern peninsula, on to Kanara, Gujarat and Kathiawar. As the name suggests, these nets

are fixed in the tidal zones of the inshore waters during low tides. To keep the nets in position, wooden poles called stakes and floats or sinkers are used. Nets are usually rectangular or conical in shape and are of differing sizes. With the high tide, they get trapped. These nets vary from state to state and are called by different local names.

Bag nets are generally conical in shape, without flanks or wings. A variation of this type with long tapering flanks is in vogue. Iruga vala of the Andhra coast, Thuri vala of Tamilnadu and Kolli vala of Kerala belong to the latter type. These nets are operated from two boats or catamarans. mathi-kolli-vala of Kerala is a specialised bag net for oil sardine fishing. Another type in Kerala is the Poithu vala, which is a large boat seine.

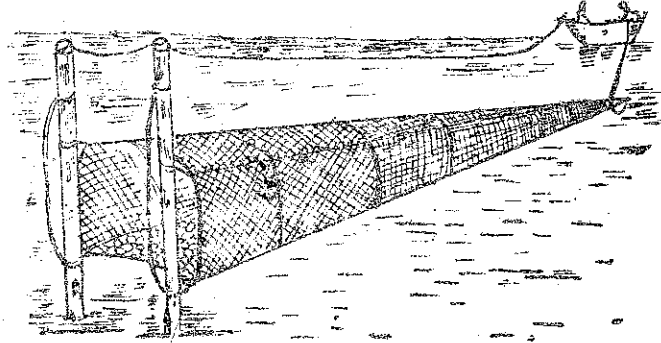

Fig. 19.29 Dol-A Bab Net of Bombay Coast.

Along the Bombay and Gujarat coasts, a very interesting type of bag net known as dol is extensively used. It is a long conical net with a wide mouth. The mouth end is fixed by bamboo poles or stakes and the tapering end is held on to a boat. This type of net is used in waters where the current is strong and high enough to keep the net straight and expanded, so that fishes can be trapped in it.

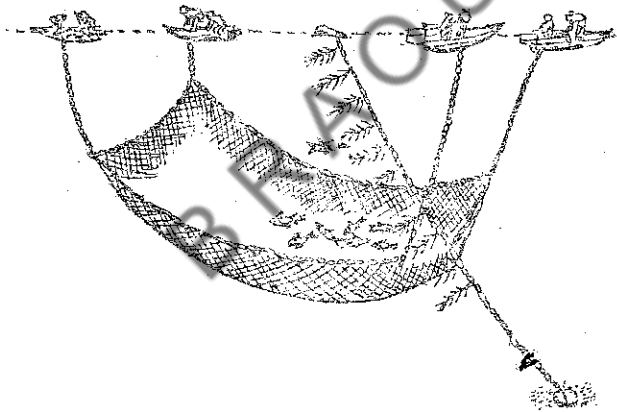

Fig 19.30 Mada valai-A shore Seine Coromandel Coast

#### Shore seines

Ber jal of Orissa, pedda or Alivi vala of Andhra Coast, periya vala or Mada valai of the Coromandel coast and Kara valai of the Gulf of Manner are the commonest examples of this type. It is essentially a conical bag with two wings. The Rampani of the Konkan and Malabar coasts extensively employed in mackerel fishing is the biggest shore seine net of the Indian seas. One end of the net is tied to a heavy stake on the shore, While a boat takes the other arm into the sea, making a semi circular sweep and back to the shore. When the net gets filled up with fishes, it is dragged to the shore by groups of men, tugging at each end.

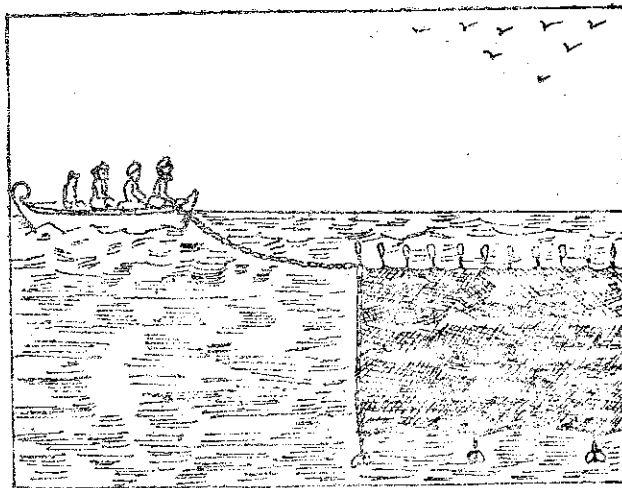

Fig. 19.31 Drift Net

Drift nets and gill nets are wall like nets of various sizes and meshes. The yarn is of hemp and sinkers and floats are attached to the net to keep it vertical and staight.

Cast nets are a popular variety of the small net operated by a single man. It has usually a string. The net is cast by the sweep of the arm. When it spreads, fishes are caught in it.

Tines and hooks are an age old device in which hooks are suspended from lines or cotton ropes. Baits are attached to these hooks. For large fishes like sharks, chain hooks are used. The lines have to be taken to the sea in boats.

The trawl netting is done in the seas generally with the help of a mechanised boat.

---

## 19.12 COMMON FISHING GEAR FOR INLAND WATERS

---

A review of the gear used in capture of fish throughout India reveals that some gears are commonly used both for inland and marine fishing. Gear such as drag nets, cast nets, traps, hooks and lines, gill nets etc. are efficiently used in inland waters. Though some gears are in common use but all are not practiced in every part of the country. Some common gear which are operated in most of the areas are given below;

### 19.12.1 Traps

The different traps used in fishing have already been discussed in this lesson. Diverse fish traps ranging from the simplest to the most complicated types are in vogue. There are multishaped cages of bamboo sticks having slit like mouth where fish can enter but cannot come out. They have diversity of shapes and sizes such as cylindrical, sub cylindrical, rectangular provided with a detachable trap door at the top. The cage is constructed of fine, closely woven bamboo splinters which are fixed by cords made of jute or other fibre. To strengthen the trap, three hoops of split bamboo or cane encircle the trap one at the mouth end and others at intervals of 20-30 cms.

Traps are set in various types of fluviatile waters like streams, riverlets, tidal creeks, irrigation channels and in paddy fields. The catch is removed from a door provided at the side or end of each trap.

### 19.12.2 Angling

Rod and liine consists of a light tapering bamboo at the tip of which a strong twine is fixed ending with a suitable hook. In case of long lining a Number of hooks ranging in size from 1.5

to 5.0 cms are attached to a strong thread at short interspace. Natural or artificial baits are used in the hook and in operating them, the fishes are attracted to the fishing area by applying flavoured fish feeds. Predatory fish such as murrel, wallago and other cat fish besides some of the craps are usually caught by this method.

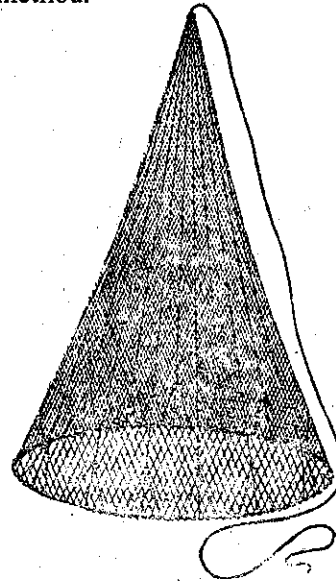

Fig 19.32 Cast Net

#### 19.12.3 Cast net

This net is employed almost throughout the year and in every locality. It is a cone shaped net, with a strong cord rope through the peripheral meshes with lead sinkers. The diameter of the net is about 3.5 meters and the number of meshes at the periphery is about 400 to 500 which converge both in number and size towards apex. The peripheral cord is provided with 100-120 lead sinkers (approximately 3 kg) at short intervals. The net is not selective and all types of fish are caught during operation.

#### 19.12.4 Stake net

The most common stake net is a conical bag net set in streams and tidal waters to filter out fish from the water. Generally the mouth of the net remains open due to the force of water current and fixed in a particular position by posts or stakes driven into muddy bottom. Two vertical stakes are set about two to three meters apart for the support of the net. In stagnant water the net is drawn by two persons from either side of the wing and filter the water from one side to the other. Fishes are caught in the bag which is periodically emptied through the opening of the tail end.

Another form of stake net which is rectangular in shape is made by fixing the head and foot ropes to bamboo strips or stakes at an equal interval of 2.5 to 3.5 meters. About 8-12 stakes over 2 to 3 m in length are normally used. However the number of stakes depends on the length of net. The net during operation by two or more persons acquires a parabolic shape. Fingerlings and marketable size fish are caught by this. It is an ideal net to collect carps and other pond fishes in small ponds.

#### 19.12.5 Hand Seines

These types of nets are commonly known as drag nets. The simplest of drag net is of a length of fry net cloth drawn by two people, each holding one end. The essential principle is to keep equal pressure on both sides while dragging the net. The net is rectangular in shape and the length of any particular net depends on the width of the water area to be hauled and accordingly

a number of small units of the same mesh are joined. The usual size of a small unit is 15 m long and 6 m wide with mesh size from 6 mm to 25 mm. In case of tanks with greater depth, the size of each unit may be 30 m x 8 m. The width of the net should be atleast twice the depth of the pond water so as to allow sufficient bag formation for sagging of the net while holding the fish catch. Very large sized drag nets with a length of 300 meters or even more and a width of 15 meters are used in deep lakes and reservoirs. In ponds and tanks fishes from surface and column layers of water are commonly caught in the belly of the net and finally dragged out of water.

#### 19.12.6 Gill nets

In ponds and tanks, gill net fishing is becoming popular due to its easy operation. The Principle of capturing fish is through entanglement and gilling in a fabric mesh. The net is a single wall of fabric, hung to a cork line at the top and lead line at the bottom. The hanging is typically somewhat loose so that when the net is set in water, the mesh openings are of vertically elongated diamond shape rather than squarish. Set gill netting and drift gill netting are practiced both in stagnant and running water.

Gill nets are of 40-50 meters long and 3-4 meters wide and 75 mm to 175 mm mesh size which are operated in ponds and tanks. But the size may vary upto 100 meters in length. Plastic floats and lead sinkers are fixed to the head rope and foot rope respectively at short distance.

#### 19.12.7 Trammel net

The net is a multiple wall of fabric suspended from the float line and extending to the lead line. The two outer ones are of the same size and are made of coarse twine and large mesh. The inner one is made of fine twine and mesh. Fishes which escape from the outer net, get entangled in the inner one. The net is commonly used in marine waters.

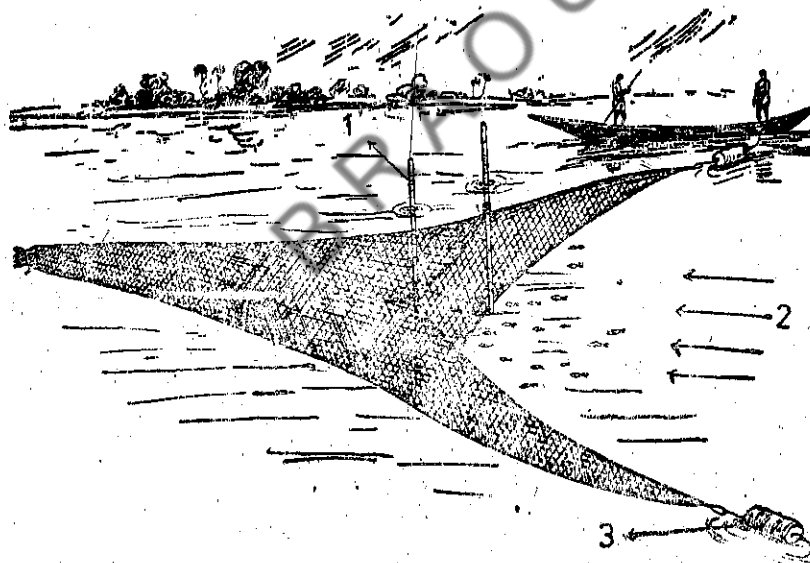

Fig. 19.33 Been Jal of West Bengal.

1. Bamboo Pole 2. Current 3. Float

Been jal is bag net set against tidal current. It is tied to stakes or bamboo poles. Floats are tied to the latter wings. This is operated in deltas of rivers of West Bengal and is used in the capture of small sized fishes.

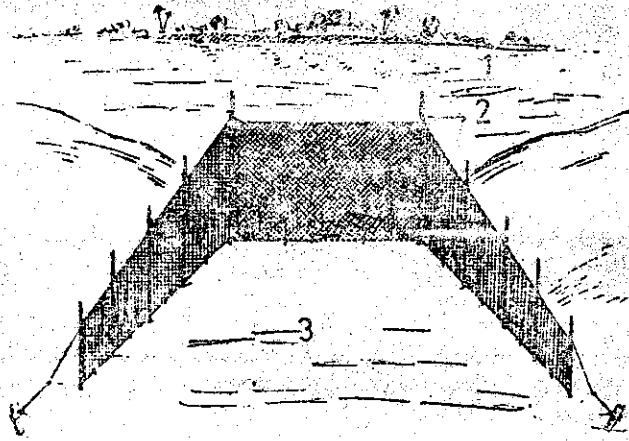

Fig. 19.34 Khal Patta Jal of Sunderbans

1. River 2. Stake 3. Khal

Khal patta jal of the Sunderbans, janos of the Chilka lake and that to vala of Kerala back waters are efficient types of gear in estuaries. The principle is to enclose portion of lagoons by means of bamboo screens or other types, so as to draw the fishes into an enclosed area. Fishes are captured by cast nets or by draining away the water at low tides.

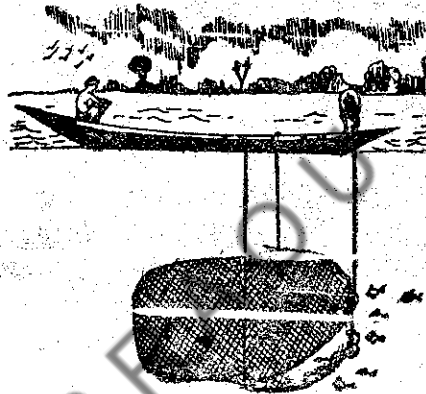

Fig. 19.35 Shanglo Jal (Purse net)

Shanglo jal is a type of purse net used in the upper reaches of estuaries. It is operated from a dugout canoe.

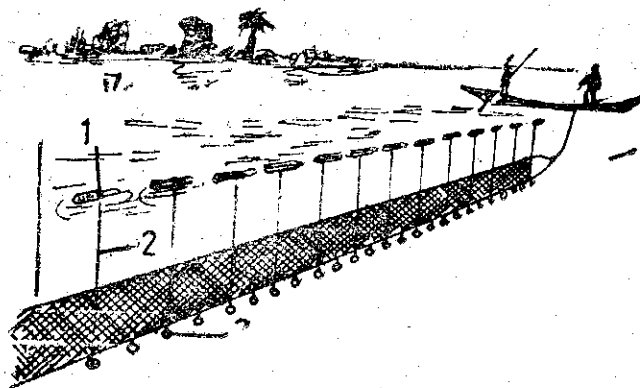

Fig. 19.36. Chhandi Jal (Drift gill net)

1. Bamboo float 2. Rope 3. Earthern weight

Chhandi jal is a drift gill net in vogue in the estuaries of West Bengal. It is an efficient gear for Hilsa fishing. Each net is 305 m long and 3 m wide, with a mesh of 7.5 to 10.2 cm.

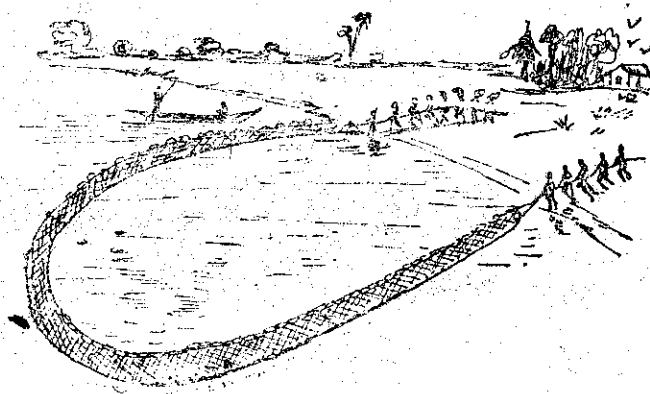

Fig. 19.37 Ber Jal (Seine net)

Ber jal is a large sized seine net in the Gangetic waters. It is operated from boats or by wading.

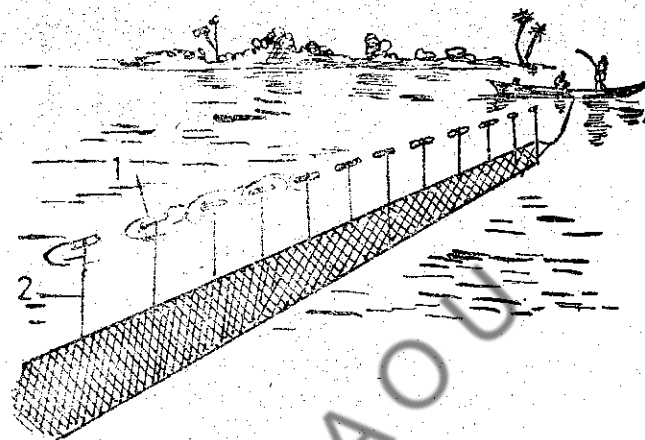

Fig. 19.38. KaraI or Katha Jal (Drift net)

1. Bamboo float 2. Rope

KaraI or Katha jal is a drift net, made of thick cotton, with 12.7-15.2 m mesh. A series of bamboo floats (about 12) are suspended by means of ropes and operated from a canoe.

---

### 19.13 GEAR FOR SPAWN COLLECTION

---

The collection of spawn from riverine resources is commonly done by operation of a gear called 'Shooting net'. The tiny hatchlings of major carps and other fishes flowing in the marginal waters of flooded rivers are sieved by the net and get collected at the posterior end of the net in a receptacle, generally known as gamcha.

#### Design of the net

Many designs of shooting net are in vogue, although only a few are more important.

#### (i) Midnapore type of net

This net has a rectangular mouth measuring about 300 cm x 60 cm. Its length is about 320 cm and has a ring made of split bamboo, of diameter around 25 cm at its cod end.

### (ii) Murshidabad type of net

The second most commonly used net is the Murshidabad type of net. This has two wings extending beyond the net in the front, while the tapering of the tail is more pronounced than the former type. These nets are very popular in the spawn collection operations in the lower gangetic basin in Bihar and West Bengal. The measurements of a typical net are length 375 cm, wing length 170 cm, wing height 80 cm, width at the net mouth 200 cm and ring diameter 25 cm.

### (iii) Lalgola type of net

The design of this net is similar to Midnapore type. The posterior tapering of the net is comparatively less, while the dimensions are generally smaller.

### (iv) Jaunpur type of net

This net is made of round meshed mosquito netting material and has an attached muslim tail piece with no provision of any ring at the cod end. This type of net is available in eastern Uttar Pradesh and Bihar.

---

## 19.14 MESH SIZE, THREAD AND WEAVING

---

### (i) Mesh size

While the Murshidabad and Lalgola type of nets mostly have 16 to 20 meshes per linear inch, the Midnapore type has mostly 8 to 16 meshes per linear inch. The Gujarat state nets used to have square meshed mosquito netting, while round (or hexagonal) meshed mosquito netting is used in Jaunpur type of nets. Multiple meshed nets are not used. Some times a selvage of 4 to 6 larger meshes of thicker thread is provided. Amongst the monofilament nylon nets introduced in recent past in some states, like Andhra Pradesh, Orissa and Uttar Pradesh, the mesh size ranges between 12 and 24 meshes per linear inch.

### (ii) Weaving

Wherever the material is cotton mosquito netting, hexagonal or rectangular meshed, the weaving pattern is well known. The Bengal nets, viz., Murshidabad, Lalgola and Midnapore types, have a leno weaving, while the nylon nets have plain weaving.

### (iii) Thread

Handloom cotton threads of counts 0 to 2 are mostly used in the cotton nets. While the smaller meshed Lalgola and Murshidabad type nets are made of finer thread, the Midnapore type is of a thicker thread. The nylon monofilament thread varies according to mesh size. Smaller meshed nets are made of 0.02 cm diameter material, while longer meshed nets are made of 0.01 cm diameter material.

---

## 19.15 GAMCHA

---

Two type of gamcha are in use:

### (i) The Midnapore type

These are made of fine meshed handloom material. These have a triangular type. While one side is tied round the ring, the other side is extended by means of two threads tied to threads tied to two bamboos. Typical measurements are length-170 cm, height-60cm and posterior width 45 cm. This creates a trough of water where collected spawn have a free ploy.

## (ii) The murshidabad type

This differs from Midnapore type in design only. A single thread extends it at the posterior end, giving it a shape of monk's hood. Hence it is also called a 'Monk's hood' type. The convergence to a vortex at the posterior in this design does not allow much space for collecting spawn. The measurements are slightly lower than those of former type, but in similar proportions.

A third type is the muslim gamcha stitched into the net in the Jaunpur type of net.

### Ring

The rings are either made of split raw bamboo or cane, tide round and fine double gutted with jute or sum hemp thread. The ring is attached to the cod end of the net. The usual diameters are from 20-25 cm.

### Tanning

The nets are usually tanned, employing the commonly available tanning material for fishing nets.

---

## 19.16 MATERIALS USED FOR FISHING GEAR

---

There is nothing which can be called an ideal net, as all of them are prepared to operate under certain conditions of weather and fishing grounds. Thus, the proper design and construction of the net is of considerable importance. For example the mesh size is of great importance for gill nets. The efficiency of the gill net also depends on the tension on the webbing which depends on the difference between weights and floats. The material of the twine, its thickness, size of mesh, number of meshes in depth, floats buoyancy, sinkers, to be used for a net depends on the type of fish to be caught and the conditions of fishing grounds.

Light nets are made of ordinary cotton threads from the market, which are spun into thicker twine composed of 3-6 threads. Stronger but coarser nets are generally prepared from hemp fibre (*Crotalaria juncea*).

### Accessories

Floats and sinkers can jointly keep the net in position. When the former lift the net, the latter keep it down. Floats are attached to the head rope. They are made from cork, wood, plastic, sponge, rubber, glass or hollow metal. Floats are generally spherical or oblong and are painted from outside. Those made of cork or wood are made water proof by applying tar.

Sinkers are attached to the foot rope and are best made of lead or iron. Stones can be used as sinkers. Sinkers of desired shape and size are also made from cement concrete. Similarly anchors are made of suitable heavy material. When a net is anchored and set in mid water or at the bottom, marking buoy consisting of a small boat with pole and flag is used to indicate the position of the net.

---

## 19.17 PRESERVATION OF FISHING GEAR

---

All types of fishing gear are liable to deteriorate, if proper care is not taken. Deterioration may be due to mechanical wear and tear caused by rubbing, bending and stretching of the components, or it may be due to getting caused by moulds and bacteria. After fishing a net is contaminated with fish slime and other organic matter, and should not be left as such overnight. It should be cleaned by washing in running water. If washing and drying is not possible, nets may be dipped in brine, or sufficient quantity of coarse common salt is sprinkled over it. Copper sulphate is also used for cleaning nets. Exposure to direct sunlight for long periods is also harmful, so the nets

must be washed immediately after use and direct in shade. A wet net is destroyed by bacteria. The best method of storing is to suspend the nets loosely in well ventilated sheds. If heating is to be done, it is better to sprinkle salt between layers.

In order to reduce chance of rotting due to bacterial action, nets are frequently 'barked'. For this various tanning materials are used. Bark of certain trees like karel wood, mangrooves, Acacia are used to prepare a decoction by boiling in water. The resultant decoction containing the tanning is cooled and the net is soaked in it for sometimes. After drying, the net is treated with the decoction a second time. By this impregnation and drying, a thin film of tannic acid is formed in the fibres and prevents bacterial action. The net is treated with 1% solution of potassium dichromate to fix the dye.

Certain nets which are subject to great wear and tear are protected by tarring. The wood tar and coal tar are equally useful. The net is put in hot tar or tar diluted with kerosene oil for 15 minutes, and is then dried. Treatment with tar increases the strength of the fibre and makes it water proof also. Preservation of net needs disinfection to kill micro-organisms. This is done either by sun drying or by treatment with a 3.5% solution of copper sulphate, copper naphenate or copper oleate.

The various methods used under the process of preservation of fishing gear are sun light, copper treatment with either copper sulphate, copper naphenate, copper oleater, cuprinol, tanning by using cutch, tar acrylonirile, argil process, acetylation and mobile deck coating oil.

### Check Your Progress

1. Coracle
2. Dugout \_\_\_\_\_ are made from a single long of wood by scooping out the inner part.
3. \_\_\_\_\_ are used to trap pelagic fish.

---

### 19.18 SUMMARY

---

In this chapter, various types of fishing craft such as coracle, Sangadam, Dhoni, Catamaran, Dugout canoes, Masula boat, Nauka, etc. are describe.

Similarly various types of fishing gear such as traps, bag nets, trawl nets, seine nets, purse seines, entangle nets, gill nets, etc. are also described.

Different types of craft and gear are required to catch different types of fishes depending upon their habit and habitat.

---

### 19.19 CHECK YOUR PROGRESS : MODEL ANSWERS

---

1. Coracle is made up of bamboos and it looks like a circular basket. it is used for fishing in rivers and reservoirs.
2. Canoes
3. Gill nets

---

## 19.20 MODEL EXAMINATION QUESTIONS

---

### I. Answer the following in about 30 lines:

1. What are the different fishing crafts used in India? Describe them in brief.
2. Describe the disabling type of fishing gear.
3. What are the filtering type of nets? Write about them in brief.
4. Discuss about the common fishing gear used in inland waters.
5. Describe the gear used for spawn collection.
6. Write about the materials used for construction of fishing craft.
7. Describe the synthetic fish net twines.

### II. Answer the following in about 10 lines.

1. Mechanization of fishing craft
2. Traps and barriers
3. Entangling type of nets
4. Protection to the fishing boats
5. Preservation of fishing gear

BRAOU

---

# UNIT - 20 PROMOTION OF FISH CULTURE, EXTENSION METHODS AND EXTENSION PROGRAMMES

---

## Contents

- 20.1 Objectives
- 20.2 Introduction
- 20.3 Promotion of Fish Culture
- 20.4 Fisheries Extension
  - 20.4.1 Functions of Extension Officers
    - 20.4.1.1 Divisional Fishery Extension Officers
    - 20.4.1.2 Subject matter specialists
    - 20.4.1.3 Chief Fisheries Extension Officers
  - 20.4.2 Extension Methods
    - 20.4.2.1 Classification of Extension Methods
- 20.5 Extension Programme
- 20.6 Summary
- 20.7 Check Your Progress - Model Answers
- 20.8 Model Examination Questions
- 20.9 Glossary

---

## 20.1 OBJECTIVES

---

This unit deals with the contributions made in the field of fisheries for promotion of fish culture. The organisation of extension wing and the functions of extension workers are discussed. The different extension methods adopted to transfer the technology to the farmers have highlighted. The programme planning of extension work has also been discussed in this unit.

---

## 20.2 INTRODUCTION

---

Notable contributions to promote fish culture. Objectives of fishery extension. Organisational pattern of extension. Functions of fishery extension officers. Extension methods-direct and indirect. Direct methods-individual contacts, group contacts, demonstrations, group discussions. Indirect methods - bulletins, news articles, personal letters, motion pictures, television etc. Need of extension programme planning. Principles of extension Programme planning. The first organised extension service in fisheries was started in the early 50s at the Central Inland Fisheries Research Institute, in the context of organising a fish seed trade. The success of the extension unit at Calcutta led to the creation of nine more extension units on a regional basis during the second five year plan. These units undertook work like survey of cultivable water areas, correction and improvement of ponds, prospecting fish seed from riverine sources, demonstrating

induced breeding, nursery practices, weed control etc. The extension unit at Mandapam took up marine extension work covering improved methods of fish handling and fish curing, use of sea weeds etc. It also took up the question of brackish water culture using Mulletts, Chanos, Pearl spot, Tilapia, live fish transport etc.

---

### **20.3 PROMOTION OF FISH CULTURE**

---

In order to promote fish production in the available culturable water bodies, researches on various aspects were conducted in the country. During the last 35 years, several advances in inland fish farming have been made, particularly as a result of researches conducted by the Central Inland Fisheries Research Institute. Some of the notable contributions in this direction are the development of:

- 1) Techniques of induced breeding of Indian major carps and exotic carps to produce quality seed.
- 2) Techniques of bundh breeding to produce pure fish seed for fish farming.
- 3) Nursery management techniques to reduce considerably the mortality in the initial stages of rearing from spawn to fry stage.
- 4) Rearing pond management techniques to reduce mortality of fry till fingerling stage.
- 5) A method for transport of spawn, fry and fingerlings in polythene bag containing water with required oxygen, with a view to reduce mortality during transport.
- 6) Stocking pond management techniques in raising table size fish from fingerlings.
- 7) Techniques for fuller utilisation of the available fish food organisms in the pond by introduction of fast growing and compatible species of Indian major carps and exotic carps in suitable combination with a view to enhance fish production from a unit area.
- 8) Techniques for augmentation of the resources of fish food organisms in the pond by fertilisation, using organic manures and inorganic fertilizers.
- 9) Feeding the fish stock by supplementary artificial feed compounded from the byproducts of agriculture.
- 10) Techniques of brackish water farming to utilise the coastal areas for raising fishes and prawns.
- 11) Techniques of fish and prawn hatchery systems to increase the fish and prawn seed production.
- 12) Techniques of breeding and culturing of fresh water prawns.
- 13) Techniques of breeding and rearing of air breathing fishes.
- 14) Techniques of integrated fish farming by involving poultry, duckery, piggery etc.
- 15) Mariculture systems particularly pearl culture and bivalve mollusc culture systems.
- 16) Suitable fishing gear and tackle.

---

### **20.4 FISHERIES EXTENSION**

---

The objectives of fishery extension with a pattern for organisational set up at National and State levels are as follows:

1. To increase the production of fish in capture and culture fisheries by applying the latest technology, for domestic consumption and for exporting.
2. To regulate fishing for optimum exploitation and conservation of fishery resources.

3. To develop hygienic handling and processing of fish and fishery products from the time of catch till marketing.
4. To arrest the exploitation of fishermen by middle men especially in marketing.
5. To improve the living standard of fishermen who are engaged in fishing and aquaculture.

#### Pre-requisites for Fishery Extension

1. Commercial production of any nature is linked with economics and marketing. Therefore, before the technology is taught to a lay man it has to undergo a test in economics of production and its scope for marketing. Only products which come out successfully in the above test should be taken up for production and extension work and until such time it should remain as an experimental project with the concerned fisheries department of the Centre/State or Agricultural University.
2. The common man, to start his own fish production, needs resources technology, area for fishing or fish culture, finance, management and marketing channels. The extension worker has to be trained not only in the fishery technology but also in management practices and marketing.
3. The latest technology in fishing/fish culture should be either developed in India by the Fisheries Institutes or borrowed from the developed countries through joint ventures.
4. A central team of experts in different disciplines of fisheries has to form a special cell to be build a reference section for the current development in commercial fishery and to pass on that information to all the extension divisions of the State Fisheries.
5. Each State fisheries should set up a special cell for extension with a Chief Extension Officer. According to the extent of water area available for fish culture/fishing, the State may be divided into as many divisions as possible and the number of extension workers are appointed in each division for specialised lines such as fresh water fish culture, brackish water fish culture, mariculture, fishing, handling, transportation, processing, marketing etc.
6. The central team should conduct refresher courses every year for all the extension workers of the State Fisheries.
7. To get qualified staff for extension work in each state the Agricultural University should start fisheries as one of the major subjects at the under graduate level.

#### Organisation Set up

##### Organisation Pattern for Fishery Extension Chief Fisheries Extension Officer (Administration)

#### Subject matter specialists

1. Fishery resources
2. Fresh water fish culture
3. Brackish water fish culture
4. Mariculture
5. Fishing
6. Processing and quality control

#### Divisional Fisheries Extension Officers

##### Field Fishery extension Officers

1. Fresh water fish culture
2. Coastal aquaculture
3. Fishing
4. Handling, processing, quality control and marketing

#### 20.4.1. FUNCTIONS OF EXTENSION OFFICERS

##### Field Fishery Extension Officers

Field Fishery Extension Officers should be selected subject wise to carryout extension in specialised line of work. According to the nature of work involved in a particular division either for

fishing or aquaculture the extension officer with proper knowledge and training in the concerned subject should be posted. The number of officers required may be decided according to the population of fishermen and the extent of area to be covered in each division. The Field Officer should keep in close contact with fishermen and study their requirements to adopt the latest technology to increase the production. They should conduct necessary audio-visual publicity, training and demonstrations on the latest technology. Periodical visits to the field should be made by the officer to follow the current development and offer necessary advice to tackle any problem. He should keep a drag record of all the fishermen families in his jurisdiction and follow their progress. Instead of working like an officer sitting in the office he should become part and parcel of the fishermen community. He should create good will and respect towards him by his talented dedicated service. A diary should be maintained by him for his day to day work.

#### **20.4.1.1. Divisional Fishery Extension Officer**

The Divisional Officers will be in charge of a division which may contain several field extension officers. By periodical visits he supervises the work of the field officer. He should prepare periodical questionnaires to the fishermen and get replies from them directly. It will help him to assess the type of assistance they are getting from the field officers. The diary maintained by field officers should also be checked by the Divisional Officer. The Divisional Officer should collect all the information in the technology from the Chief Extension Officer and pass on to the Field Fishery Extension Officer.

#### **20.4.1.2. Subject Matter Specialists**

It is highly necessary to set up reference cell comprising a team of specialists, to collect the information on day to day development in fisheries from all over the world by contacts, visits and through publications. As Fishery science has become multi-disciplinary, it is essential to create subject matter specialists in each line of commercial fisheries and build up a reference selection under him. For the current development in fisheries the following subject matter specialists should form a team under the Chief Fisheries Extension Officer in the Head quarters:

1. Fishery resources
2. Fishing technology
3. Coastal aquaculture
4. Fresh water aquaculture
5. Fish processing
6. Quality control
7. Marketing.

The subject matter specialists should also prepare extension manual in the local languages and distribute them to the field officers. They should also run a journal to pass on the day to day development in fisheries to the public. They should conduct refresher courses once in a year to the field officers.

#### **20.4.1.3. Chief Fisheries Extension Officers**

The Chief Fisheries Extension Officers will be over all in charge of the extension programme of the State. He should identify new areas for extension as per the day to day developments in fisheries. He must be able to assess the technological development in new line of fisheries for commercial exploitation. For example, the technology for sea weed culture has been developed in India as a new line for commercial exploitation. The Chief Fisheries Extension Officer should plan a programme for extension on sea weed culture in those areas where large scale culture is feasible. He should arrange the experts in India or from foreign country to teach the technology

to the field officers on commercial exploitation. He should conduct periodical meetings of the Divisional Fisheries Extension Officers to review the progress of extension work in disseminating the technology.

As India is a big country with 6100 km long coast line, encompassing extensive brackish and fresh water areas, it requires multi lateral effort to achieve practical results in production. As the development of fisheries is mainly vested with the states with different cultural and educational backgrounds, it requires a strong coastal team to co-ordinate the various agencies.

At present there is a Central Fisheries Extension Training centre at Hyderabad, The Central Marine Fisheries Research Institute, Cochin, Central Inland Fisheries Research institute located at Barrackpore, West Bengal, Central Institute of Fisheries Education, Bombay, Central Institute of Fisheries Technology, Cochin, Central Institute of Fisheries Nautical and Engineering training, Cochin, Integrated Fisheries project and Fisheries faculties of Agricultural universities at Mangalore, Tuticorin, Cochin etc., are imparting training and education in fisheries. The fisheries Division of Andhra Pradesh Agricultural university with Headquarters at Kakinada and other centers viz. Palair in Khammam dt., Kovvali in West Godavari Dt., Tirupati and Hyderabad is extending education and training in Fisheries besides conducting research on various aspects of fresh water and coastal aquaculture. The fisheries Training Institute of the State Dept. of Fisheries located at Kakinada is imparting training to the Fishermen mostly on capture fisheries.

A team of experts should not only collect the information in their relevant field but also make field visits to study the lacuna and assess the appropriate technology required for development. They should also prepare extension manuals in different languages and run a 'Fisheries Bulletin' for fishermen/ fish farmers in different languages. A joint plan of action is required to take up new lines for production and also strengthen the existing production by applying advanced technology.

#### **20.4.2. EXTENSION METHODS**

The success of Fisheries extension mainly depend upon the type of methods adopted in the extension activities. There are several methods of extension and each method has to be applied according to the situation prevailing there. The teaching of extension is based upon certain elements of a learning situation which are as follows:

##### **1. Physical facilities**

The jurisdiction of an extension worker may be either a district, block, division, mandal or the State. This particular area will constitute his class room.

##### **2. Learners**

The learners of an extension worker are fish farmers, fishermen, fisher women, boys and girls working in the field of fisheries.

##### **3. Subject matter**

The subject matter of an extension worker may include both culture fisheries and capture fisheries. The different aspects of aquaculture like fish and prawn-culture in fresh and brackish waters, fish and prawn seed production, management of ponds, mussel culture, oyster culture, frog culture etc., may be included as subject matter under culture aspects. The fishing gear and tackle, fishing craft, fishing grounds, use of different fishing equipment etc. constitute the subject matter under capture fisheries.

##### **4. Instructor**

The extension workers should be well trained in the field of fisheries and possess graduate

qualification in fisheries. An instructor should have essential characteristics of vision, initiative, tact etc.

### **5. Teaching equipment**

The equipment selected for teaching extension plays an important role in transferring the knowledge to the learners.

Teaching methods may be defined as the devices used to create situations in which communication can take place between the instructor and the learner.

Following are the functions of extension methods:

1. To provide communication so that the learner may see, hear and do the things to be learnt.
2. To provide stimulation that causes the desired mental and/or physical action on the part of the learner.
3. To make the learner realise one or more steps of the teaching learning process, viz. attention, interest, desire, conviction, action and satisfaction.

#### **20.4.2.1. CLASSIFICATION OF EXTENSION METHODS**

The methods of extension are broadly classified into direct and indirect methods: Following are some of the important direct and indirect methods adopted in Fisheries extension:

##### **1. Direct methods**

- i) Individual contacts
- ii) Group contacts
- iii) Demonstrations
- iv) Group discussions

##### **2. Indirect methods**

- i) Bulletins, leaflets, pamphlets, folders, news letters
- ii) News articles
- iii) Personal letters
- iv) Circular letter
- v) Telephone calls
- vi) Radio talks
- vii) Motion pictures
- viii) Exhibits
- ix) Posters
- x) Charts
- xi) Slides
- xii) Television
- xiii) Specimens and models

##### **DIRECT METHODS**

###### **i) Individual contact**

It is a face to face contact of the extension worker either with the farmer or with the members of his family or with the workers of the farm for one or more specific purposes connected with extension.

The objectives of individual contact are to:

1. give first hand information on matters relating to farm and to obtain information regarding the farm.
2. advise the fish farmer or to assist him to solve a specific problem or to teach skills etc.
3. arouse the interest of those not reached by other methods.
4. choose local leaders, demonstrators or co-operators.
5. promote good public relations.
6. contribute to strengthening the extension organisation or facilitate extension programme.
7. build the confidence of both the extension worker and the farmer in the utility as well as feasibility of a new practice.

#### Techniques to be followed

The following techniques or principles should be followed during the individual contacts:

The purpose and place of visit should be decided in advance. The required information in the form of leaflets, bulletin, pamphlets should be carried. The extension worker has to renew the contact with the fish farmer by reminding him the previous contact. The fish farmer has to be encouraged for the best effort he is making. The farmer has to be told about the new technique after giving a patient hearing.

#### ii) Group contacts

It is a contact of the extension worker with group of farmers or with the workers of fish farms. The group contact may be held in a neighbourhood, a community or village, a mandal, a block, a district or State. The method of presentation may be the lecture or formal talk, informal or formal discussion, or the showing of slides, or a motion picture film or a video tape.

The objectives of group contact are to:

1. reach large number of people.
2. adopt practically all lines of subject matter.
3. recognise basic urge of individual for social contact.
4. stimulate conviction to act.
5. promote personal acquaintance between extension worker and village people.
6. supplement many other extension methods.
7. create new possibilities and publicity value.
8. influence change in practice at low cost.

#### Principles to be followed

The places of visit and the number of group contacts should be decided well in advance. The necessary audio-visual aids, leaflets, bulletin should be carried. The extension work should involve the local leaders in the meeting. The techniques may be explained through the audio visual aids. The examples pertaining to some of the progressive fish farmers of the same village and the neighbouring villages should be sited. The fish farmers who are keen to adopt the technique should be noted and further information given to them.

### **iii) Demonstrations**

It is a practical implementation of either a new or old method in the field or in a laboratory in the presence of a group of fish farmers and/or workers. The method is demonstrated mainly to impress upon a group of farmers that the method can be practiced locally. The demonstrations are given either by the extension worker himself or by a trained person for the purpose of teaching the technique to a group of farmers.

The objective of the demonstrations are to:

1. make the farmers acquire new techniques.
2. enable the farmers to practice new methods in place of traditional methods.
3. know the defective methods the farmers are following and to follow the more efficient methods.
4. save time, labour and annoyance to increase satisfaction of farmers.
5. create confidence in the minds of learners that the method demonstrated can be practiced locally.

The Extension worker has to ensure that all the equipment, implements etc. required for demonstration are in working condition. The demonstration should be arranged in a local fish farm. Before the demonstration the technique adopted should be explained to the farmer. Demonstration should be made after explaining about the equipment and implements in a simple language. After completion of each step of demonstration the farmer should be asked some questions to ensure that they are following the method. At once the demonstration is completed, atleast a few farmers should be allowed to practice the method in the presence of other farmer.

### **iv) Group discussions**

Exchange of views between two or more people regarding a common problem is called 'Group discussion'. The group discussion can be held with the aid of a leader or without a leader.

The main objectives of group discussions are to:

1. exchange ideas, views and information about a common problem.
2. find out solutions to a problem.
3. evaluate a new or old method.
4. motivate other farmers.
5. plan a programme of action.

The problem to be included in the Group discussions should be identified in consultation with the local leader and fish farmers. The members should be allowed to take active part in the discussions. The extension worker should try to extract several alternate solutions to the problems from the members. The farmers should be allowed to speak one after the other without making long speeches.

## **INDIRECT METHODS**

### **i) Bulletins, leaflets, pamphlets, folders, news letters**

The purpose of writing bulletins, leaflets, pamphlets, folders and news letters is to communicate the information to the farmers.

The objectives of this type of writing are:

1. To communicate the information to a large number of people quickly and simultaneously.
2. To keep the information for future reference.

3. To provide necessary supplement to other direct methods.
4. To provide definite and easily understandable information.
5. To influence adoption of practices at relatively low cost.
6. To promote literacy.
7. To provide scope for recognising achievements of individuals and groups.

#### **Procedure to be followed**

The information to be communicated through different methods, certain principles should be followed. These principles are:

1. The most important topics on which the information is to be communicated should be identified.
2. The topics should be so selected that the information given in them could be practiced easily in their farms.
3. Use of complicated scientific words should be avoided.
4. Only the important aspects of the topic should be highlighted.
5. Set out important points step by step.
6. Give illustrations and pictures to make the reader easily understand the contents.
7. Provide sub heads to guide the reader.
8. Use simple language and familiar words.

#### **ii) News Articles**

The required information given as news through the news papers motivates the interests of a number of persons, and the best news in that which has the greatest interest for the greatest number. It is an accurate, unbiased account of the main facts of a current event which is of interest to the readers of a news paper.

The objectives of News articles are:

1. To create interest among readers
2. To give the required information to the readers.
3. To create favourable attitude.
4. To reinforce other extension activities such as meetings and demonstrations.
5. To supplement the direct methods of extension.

#### **Principles to be followed**

The important aspects should be covered in the topic in a simple language avoiding complicated words. Motivating appeals should be included. Diagrams, pictures should be illustrated wherever required. The name and address of the author should be given at the end of News article so that fish farmers interested to know information could contact the author.

#### **iii) Personal letters**

This type of extension method is applicable only in the case of literate farmers. Some farmers

write to the extension workers seeking the information. The extension worker maintains the contact by writing letters to the farmers when it is not possible to make personal visits.

The extension worker should give prompt replies to the problems raised by the fish farmers. Give complete information in the letters. Write clearly by using simple language. The writing should be neat and legible. The letter should be readable consisting of short sentences and short words. Complicated words should be avoided.

#### **iv) Circular letters**

It is a letter reproduced and sent to many farmers by the extension workers, to publicise an extension activity or to give timely information on farm problems.

The extension worker should determine the purpose of the circular letter. It should be important, timely and related to specific needs and interests. The circular letters should be organised in a series, when required. The subject matter, the number of letters, nature of contents and approximate date of distribution should be indicated. The extension worker should state the facts concerning the nature of seriousness of the problem. The solutions to the problem should be given. Letter must be neat and appealing and free from errors. Direct and simple sentences should be used.

#### **v) Telephone Calls**

Only in emergencies and only in the case of farmers having telephone facility can they get required information on phone from an extension worker. The extension worker should be brief in giving the information. He should be able to give the required information in short. The telephonic talk should be followed by personal letters or personal visits to the farmer.

#### **vi) Radio Talk**

Radio today is the most popular channel of mass communication. We are aware that the main advantage with the radio is that a message can be quickly conveyed to a large group of audience, irrespective of distance and their literacy level. It has been proved that, through radio, awareness regarding technical know how can be easily developed. Interest can be aroused and the will to adopt the information among the fishermen and fish farmers can be generated. It has also been observed that the fish farmers can be made conversant with the sophisticated and changing technology in the shortest duration.

Presently, we have Farm and Home units at All India Radio Stations to plan, prepare and broadcast programmes for rural audiences. Almost all the Radio stations have allotted time for rural broadcast. A country wide scheme of Radio-Rural Forums have been launched. These forums organised in the villages regularly discuss the weekly broadcasts and send their suggestions and criticism to radio stations. Forums have proved very useful in the dissemination of information especially to people who are poor and illiterate.

As a communicator we must see that the message for radio should be prepared in such a way that its intelligibility is very high. Listener should be able to understand the message immediately after hearing. Technical words should be avoided, doses should be repeated and translated in local language.

#### **1. The speaker should**

- i) have clear and systematic thinking on topic.
- ii) be fully prepared for the talk in advance.
- iii) be able to speak language understandably and appealingly to rural people.

- iv) have good power of expression.
- v) have rural back ground and knowledge of working with rural people.
- vi) have clear voice to pronounce the words.
- vii) not have 'milk frightness'.
- viii) know local way of speaking.
- ix) have normal speed of delivery.
- x) have sense of humour.
- xi) know 'microphone techniques'.

## **2. The subject matter relating to Radio talk should**

- i) be related to the felt needs.
- ii) be able to create a clear mental picture in the minds of the listeners regarding the subject matter.
- iii) have clear summaries at the beginning and at the end.
- iv) be done in terms of wider applicability with regard to thinking and talking.
- v) consist of only specific points.
- vi) not have complex sentences and difficult words.
- vii) have repetition of main and important points.
- viii) have economics of the practices.
- ix) have examples from actual life and from listeners experience.
- x) have limited major teaching aspects.
- xi) clarify the principle or abstract point by using examples.

## **3. The manner of presentation should**

- i) be such that at the time of speaking key ideas are stressed so that they may easily be detected by the listener.
- ii) be rehearsed carefully and properly timed.
- iii) be such that it is presented by discussion method.
- iv) be in fluent way.
- v) avoid use of 'voice fading' style.

## **4. The Radio talk should**

- i) be published in local papers.
- ii) be printed in the form of leaflets and properly distributed.

## **vii) Motion pictures**

Motion picture of film is another important and popular channel of mass communication.

Films related to Agriculture and Fisheries are also screened in the villages by the Directorate of field publicity, Development block, Educational institutions and social organisations. Films

are being produced by Indian Council of Agricultural Research in collaboration with the Film Division and other agencies.

It has been observed that it is easier to learn things if films as a medium of communication is properly used and frequently screened. Research studies have indicated that the films screened in the rural areas are outdated and presented in a drab style. The communicator while using the medium forget that this medium is being used mainly for entertainment and recreational purposes. Therefore, the message should be treated in a humorous style keeping in mind the entertainment value of the medium. It is desirable that the actors and situation are not foreign to the audience.

#### **viii) Exhibits**

An exhibit is a visual aid which is an instructional or communicating device in which the message can be seen but not heard. The exhibits are mainly displayed to influence people to adopt better practices by arousing interest in them.

#### **ix) Posters**

A poster is also one of the effective visual aids. But unlike the exhibits the poster cannot be used alone. It forms a part of the campaign or a teaching programme. It will create interest among the people. As long as the poster remains in the village it reminds the farmers about its contents.

The poster should be attractive and it should be clear and brief. The purpose of project should be made clear in the poster. The conditions and recommendations should be given due importance in the poster. The poster should be placed at an important place so that a maximum number of people watch the poster.

#### **x) Charts**

Charts are visual symbols for summarising, comparing, contrasting or performing the other services in explaining subject matter. In other words they are diagrammatic presentations of facts or ideas. The charts are also used as a part of campaign or in the teaching programme. There are different types of charts such as pull charts, strip tease charts, Flow charts, Bar charts, Time table charts, Job charts, stream charts, Flip charts, Over lay charts, Pie charts, Line charts and Pictorial graphs.

#### **xi) Slides**

Slides is also one of the visual aids. It is a transparent picture which can be projected through an electric bulb. The slides can be prepared at a low cost. The equipment for projecting the slides is slides is light and can be transported easily. Each slide can be retained for any length of time. Pictures from different angles can be taken from the fields or laboratory to make the farmers easily understand the information.

#### **xii) Specimens and Models**

Specimens are the real organisms preserved or mounted whereas a model is essentially an imitation or replica of the original. The specimens and models are either exhibited or used as a part of campaign or teaching programme to make the farmers easily understand them. These specimens and models give a clear picture to the farmers.

#### **xiii) Television**

Television is one of the powerful media of mass communication which combines all the benefits of a radio, news papers and film and thus is capable of dissemination of information, entertaining,

educating and influencing the thought and attitude of viewers. Television being an audio visual medium, the message reaches an individual through his ears and eyes and hence gets a lasting impact. In most of the developing countries it is used as an instructional tool for direct teaching, supplementing formal education developing psycho-motor skills, adult education and eradicating illiteracy. We are also using television as a medium of mass communication for fisheries extension.

The script for TV, is different from that of the radio or a news paper. In this medium there has to be perfect combination of pictures and wordage. We have to see how this combination can be worked out most effectively. To develop an effective television programme it is essential that one must follow logically the steps given below.

- i) The subject matter should not be vague. It should be made specific and need based from the audience point of view,
- ii) Determine the main points to be made in the programme. Prepare a list of items that you will make to support the point.
- iii) Consult resources material or a resource person if you need more information or you need to check the information for accuracy.
- iv) Select a format, or a method of presenting the programme. This may be a demonstration, an illustrated report, a dramatic presentation, an interview, a forum or a variety format, using several of these methods combined (The interview and the forum tend to present problems in visualising).
- v) Determine the need for other participants and contact possible participants (farmers, home makers, boys and girls, specialists and other persons).
- vi) Determine the visual aids, equipment, material and properties that best explain the points to be made. Make a list of all the visuals.
- vii) Make an outline of the programme. Divide a sheet of paper into three columns. In first column (timely segment) give the time duration of a shot. What everything's you want to show to viewers such as visual aids or the scene is to be put down in second column labelled Video. The third column will have commentary or dialogue. In other words you will put the things you want to say. This column is called as Audio column. The things you want to show and things you want to say about them should be written opposite each other on the page.

It is often necessary to use a special device to get from one segment of the programme to another. This is called a transition. It may be done visually, orally or by both. It ties the whole programme together, giving it the polished, professional touch, and results in a programme that flows smoothly. Transitions must be indicated in the script if used. Write the opening and the closing of the programme including the action and talk that will take place.

- viii) Outline of the script may be modified, according to the programme producer's suggestions. Provide a copy of the script to the programme producer, the participants and others as needed. (This should be done atleast one week before the programme is to be televised).
- ix) If give away material (a publication) is to be offered, check to make that enough copies are available to meet the expected requests.
- x) Collect the visual aids, materials, properties and equipment and lay them all out in the order of their use. Check again to make sure all of the visuals are at hand.
- xi) Rehearse the programme at home, office, or some other convenient place. Time the rehearsal for the total length and for each important segment. Add or subtract material to fit the script into the desired time. Rehearse the programme as it will be done at the station.
- xii) Arrive at the station well ahead of telecast (check with the programme producer for the time you should arrive). Acquaint the participants with the TV equipment and set, and introduce

them to the programme without cameras. If time permits, rehearse the programme with cameras.

- xiii) While the programme is being "telecast", concentrate on the subject, not on the way you are or not looking at the camera, moving your hands, and the like. This should have been taken care of in the rehearsal. Attempt to get an informal approach and treat your audience as one individual, not as a group of thousands.

Present the programme as it was outlined and as the programme producer expects it. Trust the programme producer and the technical crew to produce as good a show as they possibly can.

If something unexpected happens or you make a mistake or drop something, do not let it bother you. Recognise the mistake and continue your programme as planned.

---

## **20.5 EXTENSION PROGRAMME**

---

According to Legan an extension programme is a set of clearly defined consciously conceived educational objectives derived from an adequate analysis of the situation, which are to be achieved through extension teaching.

The purpose of extension programme is to act like a blue print and guide the extension worker in conducting the extension programme in a proper way. A well designed programme is to the extension worker what a compass is to the sea man.

### **Need of the Extension programme planning**

The Extension programme should be planned well in advance to ensure successful implementation of the programme.

Following are the important functions of Extension programme planning:

1. The Extension programme planning provides to know the job an Extension worker is supposed to do in implementing the programme.
2. It acts like a guide and unable all the concerned people to work in the right direction.
3. The programme planning facilitated to frame the necessary objectives of particular extension programme.
4. It also provides an opportunity to evaluate the programme.
5. The extension activity will not be effected inspite of change of extension workers due to a predetermined extension programme.
6. The programme planning also assists in the development of leadership.
7. It also helps in promoting the general efficiency.
8. Waste of time, money and energy can be avoided by planning the extension programme.
9. The co-ordination among the people working for the rural uplift can be achieved.
10. It ensures proper support and co-operation from the local people.
11. It helps in the assessment of financial requirements.
12. It can also be provided as a written statement for the use of general public.

### **Principles of Extension programme planning**

The following principles should be followed while planning the extension programme

1. The different steps of programme planning should be adopted for preparing, executing and evaluating extension programmes.
2. Collection, analysis and evaluation of all available and relevant facts bearing on the Welfare of the rural fish farmers
3. Determination of objectives based on the needs of the farmers.
4. Details of problems or obstacles faced in achieving the objectives or in meeting the needs of farmers.
5. Finding solutions to problems.
6. Tackling the problems on the basis of priority.
7. Planning the activities of extension programme with a view to finding solutions to particular problems.
8. Assignment of responsibilities to the individuals and groups.
9. Carrying out the extension programme as per plan step by step, in proper coordination.
10. Checking the proper implementation of extension programme.
11. Progress review with regard to the fulfilment of objectives and for continuing the programme for a further period.

### 1. Steps of programme planning

The different steps of programme planning are (a) Analysis of the situation and determining problems (b) Determination of objectives (c) Education (d) Evaluation (e) Reconsideration.

### 2. Collection, analysis and evaluation

The extension programme mainly depends on the collection of sufficient and proper facts and a scientific collaboration and interpretation of the same. The Extension worker should have thorough knowledge about the purpose for which the fish farm being utilised, the type of fish or prawn being produced in the farm, the methods adopted for raising the fish or prawns and for increasing the production in such fish farms located in the village and block level.

A thorough knowledge of the fish culture and prawn culture methods adopted, procedures of farm management and the factors of fish prawn production are essential for purposeful programme in Fisheries in any area. Hence the Extension worker, Gram sevaks, Block Development Officers should possess the complete data for preparing proper programme planning.

Though it may not be possible to list out the items suitable for all situations on which the information could be collected by the extension worker, the general information could be collected on the following lines:

#### A. General information about the village

1. Total population of the village.
2. Total number of families
3. Total number actually engaged in Fisheries activities.
4. Total number of families engaged in Fisheries activities.
5. Other main occupations of the village
6. Available transport facilities.
7. Schooling facilities

8. Medical and health facilities
9. Drinking water facilities
10. Food habits, level of nutrition etc.

**B. Information about farm management and production programmes**

1. Total area of land allocated for fisheries in the village
2. Size of an average farm
3. Minimum size of a fish farm
4. Maximum size of a fish farm
5. Type of culture such as Fish culture, Prawn culture etc.
6. Purpose for which the farm is being utilised (for example whether for seed production or for raising table size fish or multipurpose)
7. Types of fishes-prawns cultured in the farm
8. Types of culture such as mono culture or mixed culture of fishes alone or prawns alone or a mixture of fishes and prawns.
9. Water and soil quality
10. Methods adopted to eradicate fish enemies
11. Methods adopted to remove the aquatic weeds
12. Fertilizers applied (both organic and inorganic)
13. Methods adopted for eradicating the aquatic insects.
14. Type of supplementary feed given and the rate of application
15. Diseases noticed and the control methods adopted
16. Total production of fish/prawn per ha.
17. Total amount of seed produced species wise
18. Total expenditure/ha/yr.
19. Gross profit/ha/yr.
20. Net profit/ha/yr.
21. Type of fishing gear used
22. Type of traditional and improved implements used
23. Types of water sources and drainage
24. Final position of the fish farmer (long and short term debts, borrowed capital etc)
25. Sources and facilities of securing credit
26. Problems of farm labour
27. Available storage facilities
28. Transport facilities to transport the fish/prawn
29. Marketing facilities

The Extension workers, village level workers, Block Development officers, Gram sevaks should strengthen the local institution such as panchayat co-operative societies, the school, rural youth

club by collecting the factual data through them and using them for building the programme at the family, village and Block levels. The extension workers should develop leadership qualities so that the local problems on priority basis, could be identified. The data collected by the Extension worker should be passed on the Gram Panchayat or panchayat samithi or to the Block for the purpose of review. This will facilitate the institution to decide which problem to be tackled first on priority basis.

### **3. Objectives of the programme**

The Extension worker would formulate the objectives of extension programme while planning the programme in consultation with the villagers. The family extension programme should be decided by the head of the family and the village programme should be determined by the Gram Panchayat. The co-operative societies functioning in the village should also assist the villagers in determining the objectives of the programme. The objectives should specify the main aim of the programme, besides aiming at the social and economic changes of the fish farmers.

### **4. Details of problems**

During the programme planning certain problems will be faced. The problems can be classified into those categories viz. problems which can be solved by the villagers with their own resources, problems that need community co-operation without involving much outside assistance and problems that require assistance from outside on account of high costs involved and the technical knowledge needed.

### **5. Finding solutions to problems**

The problems faced in programme planning should be solved with the assistance of Extension worker. They should solve the problems in such a way that it is more practicable and economical. In cases where the extension worker is not able to solve the problems for himself, he should take the advise of experts in the field. If necessary the Extension worker should involve the experts to solve the problems in the presence of farmers.

### **6. Tackling the problems on priority**

All the problems faced during the programme planning cannot be tackled at a time. The problems should be tackled in a phased manner giving priority to such of the problems which require more importance. This will result in the appreciable achievements and convince the fish farmers about the utility of the programme.

### **7. Plan of activities**

With a view to solve the problems the plan of activities should be prepared. A plan of work is the listing of activities by which the objectives already decided upon are to be achieved. The different bodies such as Gram Panchayats, Mandals etc. should formulate the plan of activities with the assistance of Extension workers.

### **8. Assignment of responsibilities**

The various responsibilities in planning the extension programme should be assigned to the individuals and groups. The Extension worker should take a lead in the matter and allocate the responsibilities basing upon their previous performance, experience and the type of work.

### **9. Carrying out the plan**

Every activity of the programme should be carried out step by step in a planned way by involving the Extension workers, village level workers, local institutions, the Block Development officers,

Panchayat samithi. Arrangements should be made for the supply of fertilizers, weedicides, piscicides, fish/prawn seed, supplementary feeds, nets, audio visual aids, literature etc. Before carrying out the extension programme as per plan necessary training programme should be organised. The programme should be discussed with the local leaders and fish farmers before the programme is implemented.

#### **10. Checking the implementation of programme**

An effective plan of work required the keeping of adequate records of each activity as a basis for further evolution. After the completion of extension programme evaluation has to be made to found how far the objectives of the programme have been achieved. The evaluation also helps in determining the effectiveness of extension work. It will also facilitate to plan the desirable modifications in the programme planning, the effective extension methods, the needs of people can also be identified as a result of evaluating the programme.

#### **11. Review of progress**

Due to the variations in socio-economic conditions of fish farmers every phase of the programme should be reviewed. The progress of programme should be reviewed by the institutions such as Panchayat samithies, co-operative societies, block etc. Programmes which are successful in a particular village should be extended to the neighbouring villages depending upon the needs and conditions prevailing there. The programmes which are not accepted by the farmers should also be reviewed and the reasons for their rejection should be ascertained.

#### **Check Your Progress**

Write few lines about Dinghi and Nauka

---

### **20.6 SUMMARY**

---

In this chapter the promotion of fish culture, extension methods and extension programmes are explained in detail. The idea of the extension methods is to increase the production of fish in Captivity, and to regulate fishing for optimum exploitation are discussed.

Field, fishery extension officers, Divisional fishery extension officers, subject matter specialists and Chief Fisheries extension officers who will develop and process about extension programmes are discussed in detail in this chapter.

Extension methods such as group discussion, new articles, radio talks, T.V. talks are also explained here.

---

### **20.7 CHECK YOUR PROGRESS - MODEL ANSWERS**

---

#### **1. Dinghi and Nauka:**

These are Carvel boats of Orissa and West Bengal. Naukas which are well designed and constructed upto a size of 13m x 3m x 2m are quite spacious and are used for a variety of purposes including fishing operations.

---

### **20.8 MODEL EXAMINATION QUESTIONS**

---

#### **I. Answer the following in about 30 lines:**

1. Write about the promotion of fish culture in the country. What are the major contributions in this direction?

2. What are the functions of Fishery Extension officers?
3. Write about the method of 'Individual contacts'?
4. What is a 'Group contact'? Mention the principles to be followed in the Group contacts.
5. What are the objective of 'Demonstrations' of Fishery extension? Write about the principle to be followed in Demonstrations?
6. Write about the 'Group discussions' as one of the direct methods of Fishery extension?
7. How Radio talks promote Fishery extension work? What are the points to be borne in mind while planning for a Radio talk?
8. Describe the role played by Television in promoting the Fishery extension?
9. What are the functions and principles of extension programme planning?
10. Write about collection, analysis and evaluation while planning the Extension programme?

**II. Answer the following in about 10 lines:**

1. Prerequisites for fishery extension
2. Different extension methods
3. News Articles
4. Motion pictures
5. Bulletins, leaflets etc.

---

**20.9 GLOSSARY**

---

Acrid	:	Bitter
Aerobic	:	Requiring free oxygen to maintain life processes.
Algal bloom	:	A sudden increase in the abundance of planktonic algae, especially at a near the water surface. A condition when water looks green because of the abundance of planktonic algae.
Algicide	:	Algae destroying agent.
Alkalinity	:	Number of hydroxyl ions released in water, giving a pH higher than 7.
Allochthonous	:	Due to outside factors.
Anaerobic	:	No requiring free oxygen to carry on respiration.
Anion	:	Electrically negatively charged ions.
Antibodies	:	Protein molecules in the blood which fight the bacteria.
Aperthy	:	Carelessness; Dull
Autochthonous	:	Due to within factors.
Back waters	:	Settlement of sea water in the low lying areas along the coastal areas; fed by tides or seepage from the Sea. Generally the salinity is very high.
Berm	:	A narrow path made between the base and the top of embankment.
Biosmass	:	Plant and animal matter existing in a water body expressed quantitatively.
Brackish water	:	Mixture of sea water and fresh water with a salinity of less than 30 parts per thousand.

Brood fish	:	Sexually matured fish, especially for breeding in fish farms.
Carapace	:	A continuous shield like exoskeletal covering of the cephalothorax.
Carrying capacity	:	The maximum quantity of that any particular water body can support over a long period.
Cation	:	Electrically positively charged ion.
Debility	:	Weakness
Decalcification	:	A process in which due to the uptake of carbon dioxide (by plants) the equilibrium between calcium bicarbonate and the pressure of carbon dioxide in water is destroyed, resulting in the precipitation of calcium carbonate.
Decarboxylation	:	Degradation of carboxylic acid. By this process carbon dioxide is eliminated to form new compounds.
Demersal	:	On the bottom; also applied to fish eggs which sink to the bottom where they catch.
Diurnal	:	Pertaining to day and night.
Draught	:	1. Pulling in of a net for fish, the fish caught in it. 2. Depth of water needed to float a boat.
Drip	:	Flow of tissue fluids from the frozen fish a muscle during freezing.
Dyke	:	Long ridge or embankment.
Ecological niche	:	A particular role (or set of relationships) of organism in an ecosystem which may be filled by different species in different geographical areas. Ex : Zooplanktophagic <i>Catla catla</i> in India and <i>Aristichthys nocilis</i> in China.
Estuarine environment	:	The region where the river enters into the sea, with tidal fluctuations of salinity.
Entropiscation	:	The complete sequence of changes whereby deep clean water body of low productivity gradually becomes shallower and more productive, eventually filling up completely and becoming dryland.
Exopodite	:	Outer basal portion of prawn appendage.
Exotic	:	Introduced from abroad.
Facultative parasite	:	Parasitizing under certain circumstances only.
Fecundity	:	Breeding capacity a fish or prawn at a given time (i.e. no. of mature eggs present with ovary at a given time).
Ferrugious	:	Contaminated with Iron.
Fillet	:	Strips of flesh cut parallel to the back bone of the fish.
Fish kill	:	Massive, rapid death of fish due to several reasons such as oxygen deficit, inflow of toxicants, infections diseases etc.
Fish seed	:	Fish juveniles including the hatchings, fry and fingerling stages.
Fry	:	Advanced post larval stage of fish before becoming adults.
Glycerides	:	Esters of fatty acids and glycerol.
Gunwale	:	Upper edge of a boat's side.
Hatching	:	The early larva that emerges out of the hatching of the fertilized egg.
Herbicide	:	A chemical or other product (uses any poisonous) used for destroying weeds.

Herbivorous fish	:	Fish feeding on plants.
Hull	:	The frame of a boat.
Impoundment	:	An artificial body of water, Reservoir.
Infections disease	:	Diseases caused by infection.
Interspecific	:	Referring to events or relationships which occur between individuals of different species.
Intraspecific	:	Referring to events of relationships which occur between individuals of the same species.
Keel	:	The principal supporting timber located at the lower portion of a boat.
Lab lab	:	Biological complex consisting of decayed green and blue green algae, diatoms, protozoa, bacteria a
Leaching	:	Washing out
Lesious	:	Wounds
Nauplius	:	First is a series of larval phases in crustaces.
Osseous	:	Bony
Parameters	:	Factors; aspects affecting
Perennial	:	Throughout the year
Pereopods	:	The appendages of a prawn attached to the thoracic region.
pH	:	Hydrogen ion concentration.
Phagocytize	:	Absorb; eat
Phytoplankton	:	Free floating microplants with chlorophyll synthesizing stonches in the presence of sunlight.
Pleopods	:	The abdominal segments of a prawn on the ventral side.
Polymerization	:	A chemical reaction which is capable of proceeding indefinitely either by condensation or addition of small molecules and give a compound of infinite molecular weight.
Prophylactic	:	Precautionary
Raft	:	A fleet of wooden legs.
Ramming	:	Beat down the soil with wooden or iron block with face.
Rancidity	:	Unpleasant odour.
Recruitment	:	Addition of new fish to the volnerable population by growth from among smaller size categories.
Relative condition	:	Observed weight of fish or prawn divided by calculated weight, obtained from length. Weight equatioon.
Sponification	:	Hydrolysis by an alkali.
Seepage	:	Leakage of water through porous sand or mud.
Siltatiar	:	Deposition of finally divided sediments, consisting of rock and clay particles.
Skimmed	:	To clear from any substance floating on the tip of a liquid.
Sluice	:	A structure for impounding the water of a canal, neck etc., provided with a sluice gate by which the volume of water into regulated.
Stacking	:	Piled up is a regular form for keeping and often hatched.
Stakes	:	Strong pointed sticks driven into the ground as post or support.
Stocking rate	:	Number of fish released for unit area.
Stressors	:	Aduerse environmental condition.

<b>Telson</b>	:	The posterior most triangular part of the abdomen in a prawn.
<b>Toxicity</b>	:	Lethal effect.
<b>Turbidity</b>	:	Water which is not clear and into which light cannot pass through.
<b>Warpsing</b>	:	Usage of long sopes for fishing.
<b>Weir</b>	:	Wall or similar structure built across a river to control the flow of water.
<b>Zooplankton</b>	:	Free floating microanimals, including small adult animals and larval form of some of the adult aquatic animals.

BRAOU

BRAOU

**DR. B.R. AMBEDKER OPEN UNIVERSITY**  
**UNDERGRADUATE COURSES - THIRD YEAR**  
**ZOOLOGY**

**COURSE - 4: FISHERY SCIENCE**

**SYLLABUS**

Fishery Institutes in India

The migration of Fishes.

Anatomy of a bony fish.

Introduction of Fish Culture, History, Present status and Fishery resources.

Selection of species for culture, Taxonomy and identification of cultivated Fishes and Prawns.

Food and Feeding. Age and growth and breeding habits of important fishes and prawns.

Life history and identification of eggs, larva and juveniles of cultivated fishes and prawns.

Seed production - Collection of seed from natural resources and bundh breeding.

Seed production - Induced breeding, hatchery systems and seed transport.

Farm pond - Site selection, Design and Construction of Pond.

Farm Pond Water and soil quality, food chain and productivity.

Farm Pond - Pond management.

Freshwater Aquaculture systems.

Coastal Aquaculture and Mariculture systems

Fish nutrition and health monitoring - Nutritional requirements and supplementary feeding

Fish Diseases - Causes, symptoms and control.

Fishery Technology - Preservation, Processing and Transportation.

Byproducts.

Crafts and Gears.

Promotion of Fish culture, Extension methods and Extension Programmes.

SECRET

BRAOU

**DR. B.R. AMBEDKER OPEN UNIVERSITY**  
**FACULTY OF SCIENCES**  
**THIRD YEAR (3 YEAR DEGREE COURSE) EXAMINATION**

**MODEL QUESTION PAPER**

**COURSE-IV: FISHERY SCIENCE**

**Time: 3 hours**

**Max. Marks: 75**

**Section - A**

**Answer any 3 questions**  
**Each question carries 15 marks**  
**Answer the following in about 30 lines each.**

1. Discuss the latest advancement and practices of transportation of fish in our country?
2. Write about the migration of fishes?
3. Describe the economic (investments and returns) of a composite fish culture pond?
4. Give an account of seed production techniques of air breathing fishes?
5. Describe the formation of natural pearls. Write about the cultural pearl technique?
6. Give a brief historical background of Fishery in India?

**Section - B**

**Answer any 5 questions**  
**Each question carries 6 marks**  
**Answer the following in about 10 lines each.**

7. Fish cum duck culture in Indian economy?
8. Role of fish culture in Indian economy?
9. Describe the prawn and fishes suitable for brackish water farming?
10. Write different methods of drying of fish?
11. How would you test the freshness of a fish?
12. Write the identifying characters of milk fish?
13. Write briefly about the hatchery sanitation programme?
14. Non-infectious diseases of fish?
15. Liming of pond?
16. Topography of selected site for farm pond construction?

THE UNIVERSITY OF MICHIGAN LIBRARY

ANN ARBOR, MICHIGAN

1968

1968

1968

1968

BRAOU

**DR. B.R. AMBEDKER OPEN UNIVERSITY**  
**UNDERGRADUATE COURSES - THIRD YEAR**  
**ZOOLOGY**

**COURSE - 4: FISHERY SCIENCE**

**ASSIGNMENT - 1**

**N.B.**

1. Do not copy the answer directly from any of the books.
  2. As far as possible try to answer the questions independently in your own words
  3. If it is necessary to quote from any source give the correct reference.
  4. Use your own fullsize pages for writing the assignment.
  5. Leave sufficient margins for the comments of the evaluator.
  6. Completion of this assignment should not take more than two hours time.
- 

**I. Answer the following questions in about 30 lines.**

1. Describe the formation of natural pearls. Write about the cultured pearl technique.
2. What is "Bundh"? Describe how the bundhs help in the breeding of carps.
3. Give a brief historical background of Fishery in India.

**II. Answer the following questions in about 10 lines.**

1. Write different methods of drying of fish.
2. Fishing crafts
3. Stocking of Fry in rearing ponds.

cut here

BRAOU

**DR. B.R. AMBEDKER OPEN UNIVERSITY**  
**UNDERGRADUATE COURSES - THIRD YEAR**  
**ZOOLOGY**

**COURSE - 4: FISHERY SCIENCE**

**ASSIGNMENT - 2**

**N.B.**

1. Do not copy the answer directly from any of the books.
  2. As far as possible try to answer the questions independently in your own words.
  3. If it is necessary to quote from any source give the correct reference.
  4. Use your own fullsize pages for writing the assignment.
  5. Leave sufficient margins for the comments of the evaluator.
  6. Completion of this assignment should not take more than two hours time.
- 

**I. Answer the following questions in about 30 lines.**

1. Write about Mussel culture.
2. Describe briefly the different fishing crafts used in our country.
3. Describe the gear used for 'spawn' collection.

**II. Answer the following question in about 10 lines.**

1. Write the identifying characters of milk fish.
2. How fish seed packed and transported.
3. How would you test the freshness of a fish.

cut here

BRAOU

**DR. B.R. AMBEDKER OPEN UNIVERSITY**  
**UNDERGRADUATE COURSES - THIRD YEAR**  
**ZOOLOGY**

**COURSE - IV: FISHERY SCIENCE**

**ASSIGNMENT - 3**

**N.B.**

1. Do not copy the answer directly from any of the books.
2. As far as possible try to answer the questions independently in your own words.
3. If it is necessary to quote from any source give the correct reference.
4. Use your own fullsize pages for writing the assignment.
5. Leave sufficient margins for the comments of the evaluator.
6. Completion of this assignment should not take more than two hours time.

**I. Answer the following questions in about 30 lines.**

1. Discuss the latest advancement and practices of transportation of fish in our country.
2. List the different methods of preservation of fish and write briefly about the refrigeration and freezing process.
3. Explain the pre-treatment given to the raw material before canning of fish.

**II. Answer the following questions in about 10 lines.**

1. Give a brief historical background of Fishery in India.
2. Liming of pond.
3. Objectives of Fishery extension.

cut here

UNION OF INDIA  
GOVERNMENT OF INDIA

BRAOU